

**Series 4, Telescopic cooker hood, 60 cm, Silver metallic DFS067A51B**



**Telescopic cooker hoods extend when in use and slide neatly away when not in operation.**

- **EcoSilence Drive™**: the powerful, energy-saving drive for hoods.
- **High extraction rate - for continuously clean air in the kitchen.**
- **Intensive Setting**: the powerful way to beat intense steam during cooking.
- **Enjoy the benefits of a cleaner and healthier kitchen, free from excessive grease and unwanted odors.**
- **LED Illumination**: The energy-saving lighting provides bright and clear lighting for the hob area.

DSZ4660	Lowering frame
DSZ4682	Handle strip white
DSZ4686	Handle strip black
DWZ0IT0P0	Long Life odor filter (replacement)
DWZ1IT1D1	Long Life recirculation kit external
DWZ1IX1B6	Clean Air Plus odor filter (replacement)
DWZ1IX1C6	Clean Air Plus recirc. kit external
DWZ2IT1B4	Clean Air Standard odor filter (repl.)
DWZ2IT1I4	Clean Air Standard recirculation kit

Typology:	..... Pull-out
Length electrical supply cord:	..... 175.0 cm
Min. required niche size for installation (HxWxD):	..... 385mm x 524.0mm x 290mm mm
Height of the appliance:	..... 426 mm
Minimum distance above an electric hob:	..... 430 mm
Minimum distance above a gas hob:	..... 650 mm
Net weight:	..... 10.6 kg
Type of control:	..... Electronic
Number of speed settings:	..... 3-stages + intensive setting
Max. air extraction:	..... 399 m <sup>3</sup> /h
Boost position output recirculating:	..... 628 m <sup>3</sup> /h
Max. air recirculation:	..... 358 m <sup>3</sup> /h
Boost position air extraction:	..... 728 m <sup>3</sup> /h
Maximum Air flow:	..... 399 m <sup>3</sup> /h
Number of lights:	..... 2
Noise level:	..... 53 dB(A) re 1pW
Diameter of air outlet:	..... 120 / 150 mm
Grease filter material:	..... Washable stainless steel
EAN code:	..... 4242005232062
Connection rating:	..... 144 W
Fuse protection:	..... 10 A
Voltage:	..... 220-240 V
Frequency:	..... 50; 60 Hz
Plug type:	..... GB plug
Installation typology:	..... Built-in



## Series 4, Telescopic cooker hood, 60 cm, Silver metallic DFS067A51B

**Telescopic cooker hoods extend when in use and slide neatly away when not in operation.**

- Built-in dimensions (HxWxD): 385 x 524 x 290 mm
- Diameter pipe  $\varnothing$  150 mm ( $\varnothing$  120 mm enclosed)
- Electrical cable length 1.75 m

\* In accordance with the EU-Regulation No 65/2014

### Features

- Electronic control via Soft touch button control
- 3 power levels & intensive setting
- 2 x 1,5W LED
- Efficient BLDC technology
- Automatic intensive revert (6mins)
- Automatic after running (Automatic after running (10 min))
- 2 removable metal grease filter cassettes

### Design

- 60 cm wide
- Silver metallic lacquer
- Handle strip specification: stainless steel with logo
- Steel filter cover

### Performance

- Suitable for ducted or recirculating operation
- For recirculated extraction recirculating kit or CleanAir recirculating kit (accessory) needed
- Energy Efficiency Class: A (at a range of energy efficiency classes from A+++ to D)
- Extraction rate according to EN 61591 max. 728 m<sup>3</sup>/h
- Extraction rate according to EN 61591  $\varnothing$  15 cm:
  - max. Normal use 399 m<sup>3</sup>/h
  - Intensive 728 m<sup>3</sup>/h
- Noise level according to EN 60704-3 and EN 60704-2-13 at max. normal use exhaust air: 53 dB(A) re 1 pW
- Extraction rate exhaust air according to EN 61591:
  - max. normal use 399 m<sup>3</sup>/h, intensive 728 m<sup>3</sup>/h
- With the Clean Air Plus recirculation kit (available as optional accessory) your appliances reaches:
  - Extraction rate in recirculation mode: Max. normal use: 358 m<sup>3</sup>/h
  - Intensive: 628 m<sup>3</sup>/h
  - Noise level in recirculation mode: Max. normal use: 60 dB(A) re 1 pW
  - Intensive: 71 dB(A) re 1 pW
- 2 single inlet vertical, Efficient BLDC technology
- Colour Temperature: 3500 K
- Light Intensity: 294 lux
- Power rating: 144 W
- Average Energy Consumption: 37.9 kWh/year\*
- Blower Efficiency Class: B\*
- Lighting Efficiency Class: A\*
- Grease Filtering Efficiency Class: B\*

### Planning and installation information

- Installation system: Telescopic comfort installat.
- Installation: Cupboard 60 cm
- Dimensions (HxWxD): 426 x 598 x 290 mm

**Series 4, Telescopic cooker hood, 60 cm, Silver metallic  
DFS067A51B**

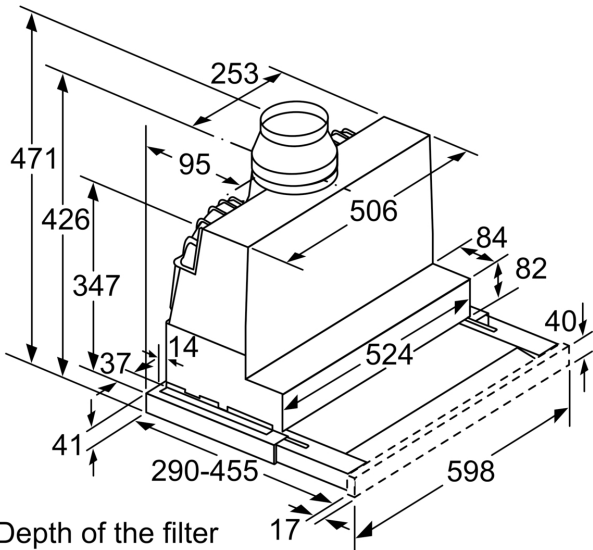

Depth of the filter drawer can be adjusted by up to 29 mm

measurements in mm

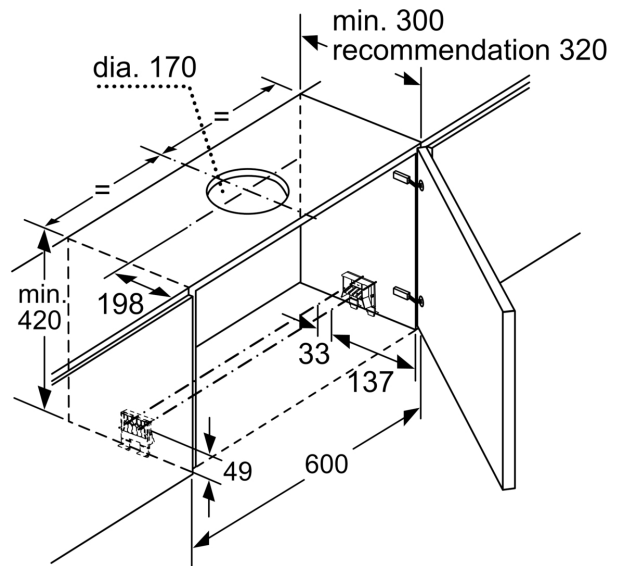

measurements in mm

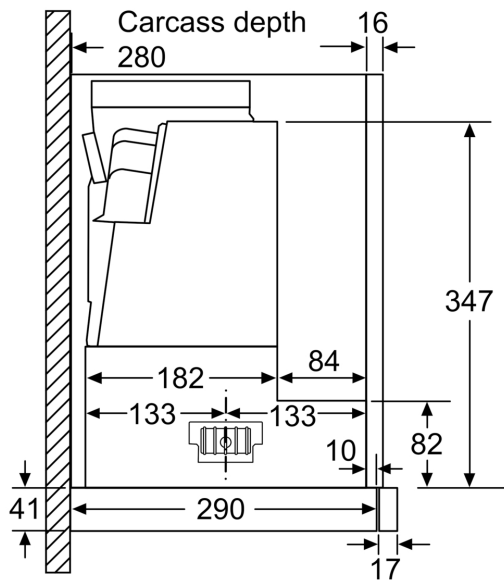

measurements in mm

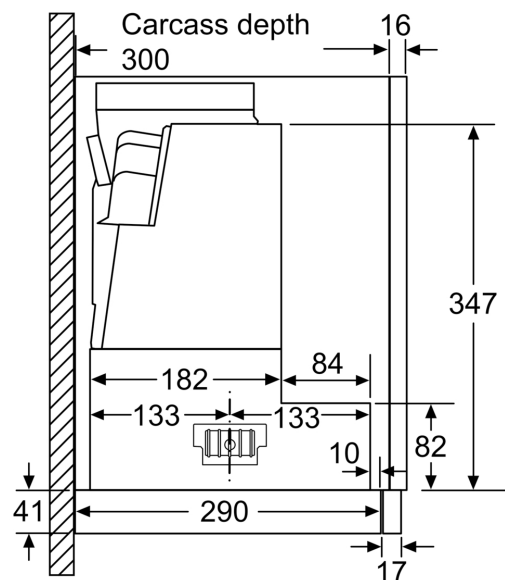

measurements in mm

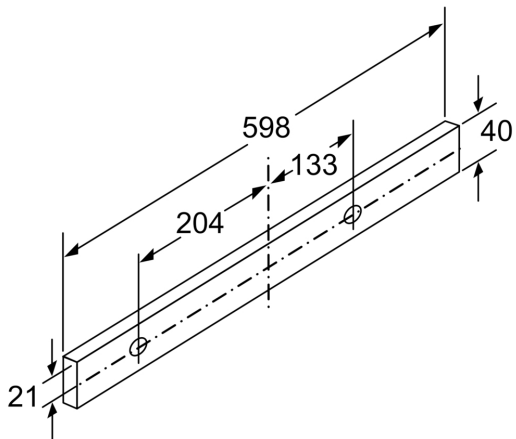
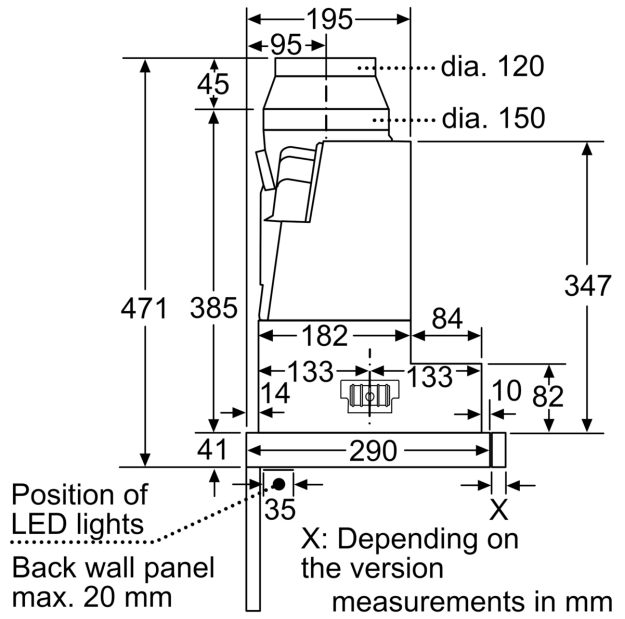
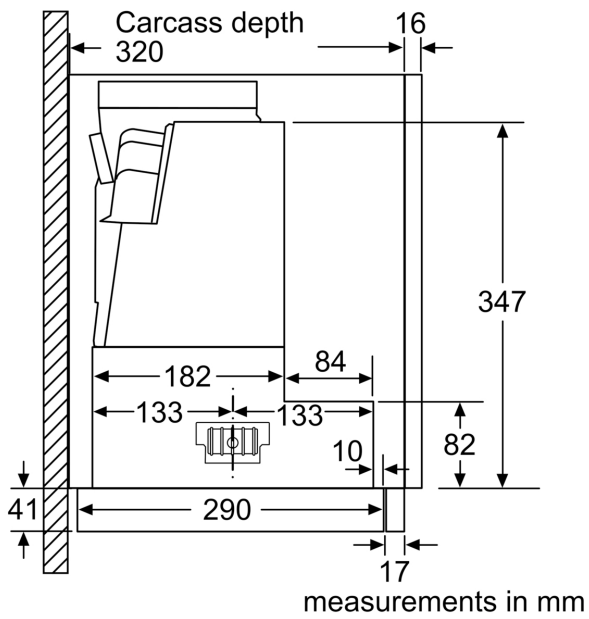

measurements in mm