

Series 8, Downdraft hood, 80 cm, clear glass DDW88MM60B



DSZ1WW1B6 Clean Air Plus odor filter (replacement), DSZ1WW1I6 Clean Air Plus recirculation kit, DSZ1WW1J1 Long Life recirculation kit, DSZ1WW1M1 Installation kit remote motor, DSZ8WW1Y2 Mounting kit for seamless installation, DZZ1WW1X1 Flat duct adapt.round 90° DN150 Metal, DZZ1XX1X1 Aluflex pipe cyl. 150, HEZ9VDSB1 90° flat duct bend horizontal, HEZ9VDSB2 90° flat duct L vertical, HEZ9VDSI0 Adapter round-flat, HEZ9VDSI1 90° Adapter round-flat, HEZ9VDSM1 Straight tube 500mm, HEZ9VDSM2 Straight tube 1000mm, HEZ9VDSS1 Connector sleeve (female)

- Innovative design meets powerful performance.
- **Hob-based Hood Control:** Say goodbye to the hassle of separate controls and hello to a cooking experience that is truly seamless.
- **EcoSilence Drive™:** the powerful, energy-saving drive for hoods.
- **PerfectAir sensor:** automatic control of settings for maximal extractor performance with minimal noise.
- **Intensive speed setting:** removes strong kitchen odours quickly and effectively.

Typology:Downdraft
 Length electrical supply cord: 130.0 cm
 Min. required niche size for installation (HxWxD): 703mm x 781.0mm x 123mm mm
 Height of the appliance: 709 mm
 Net weight:36.0 kg
 Type of control:Electronic
 Number of speed settings:3-stage + 2 intensive
 Max. air extraction: 501 m³/h
 Boost position output recirculating: 525 m³/h
 Max. air recirculation: 416 m³/h
 Boost position air extraction: 775 m³/h
 Maximum Air flow: 501 m³/h
 Noise level:62 dB(A) re 1pW
 Diameter of air outlet: 150 mm
 Grease filter material: Washable stainless steel
 EAN code:4242005450688
 Connection rating: 300 W
 Fuse protection:10 A
 Voltage: 220-240 V
 Frequency: 50; 60 Hz
 Plug type:GB plug
 Installation typology: Built-in



Series 8, Downdraft hood, 80 cm, clear glass DDW88MM60B

Measurements in mm

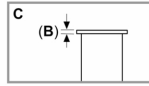
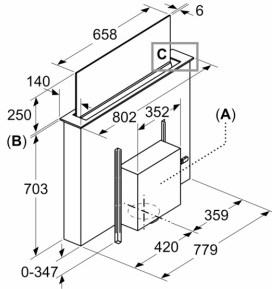

A: Installation of motor unit on front/rear or offset laterally with max. 3 m clearance (special accessory required)

Motor unit must always be accessible

B: 5.5 mm

Measurements in mm

Standard, top-mounted installation

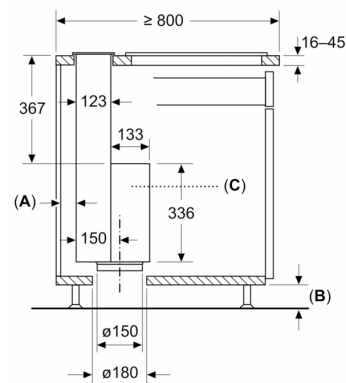

Standard: with worktop divider between downdraft and hob

A: ≥ 20 mm between the Guided Air suction area and a cabinet wall

B: ≥ 60 mm for air recirculation

≥ 100 mm for air extraction with ducting in the plinth

C: Motor unit must always be accessible

Measurements in mm

Seamless, top-mounted installation

(Special accessory required)

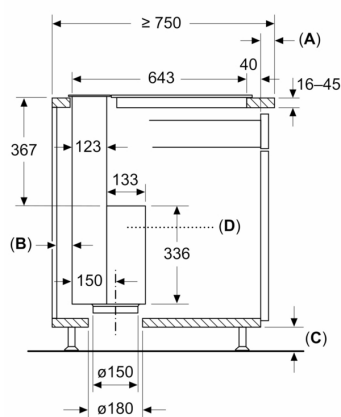

A: Worktop overlap to kitchen cabinet

B: ≥ 20 mm between the Guided Air suction area and a cabinet wall

C: ≥ 60 mm for air recirculation

≥ 100 mm for air extraction with ducting in the plinth

D: Motor unit must always be accessible

Measurements in mm

**Combination with electric hob
Seamless, top-mounted installation**

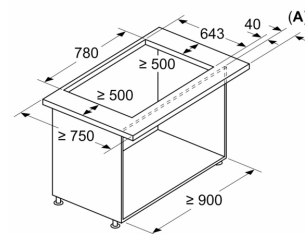

A: Worktop overlap to kitchen cabinet

Combination with gas hob is not possible

To prevent power loss, observe the following:

- Do not install upper cabinets or open shelf elements above the appliance
- Left/right distance between appliance and wall/adjacent upper cabinet min. 500 mm
- Distance between appliance frame and wall min. 50 mm

Measurements in mm
Combination with electric hob
Standard, top-mounted installation

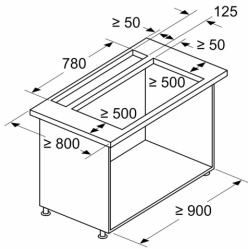

- Standard: with worktop divider between downdraft and hob
- Combination with gas hob is not possible
- To prevent power loss, observe the following:
- Do not install upper cabinets or open shelf elements above the appliance
 - Left/right distance between appliance and wall/adjacent upper cabinet min. 500 mm
 - Distance between appliance frame and wall min. 50 mm

Planning recommendation, air recirculation

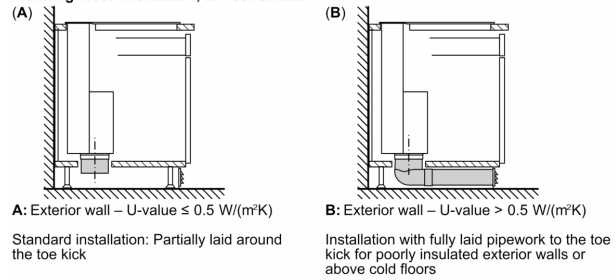

Measurements in mm
Combination with electric hob
Seamless, top-mounted installation

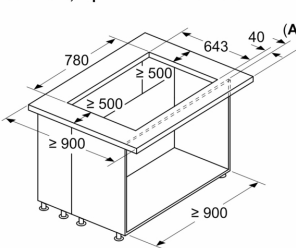

- A:** Worktop overlap to kitchen cabinet
- Combination with gas hob is not possible
- To prevent power loss, observe the following:
- Do not install upper cabinets or open shelf elements above the appliance
 - Left/right distance between appliance and wall/adjacent upper cabinet min. 500 mm

Measurements in mm
Combination with electric hob
Standard, top-mounted installation

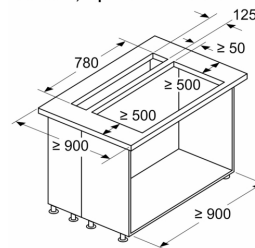

- Standard: with worktop divider between downdraft and hob
- Combination with gas hob is not possible
- To prevent power loss, observe the following:
- Do not install upper cabinets or open shelf elements above the appliance
 - Left/right distance between appliance and wall/adjacent upper cabinet min. 500 mm

Measurements in mm
Standard, top-mounted installation

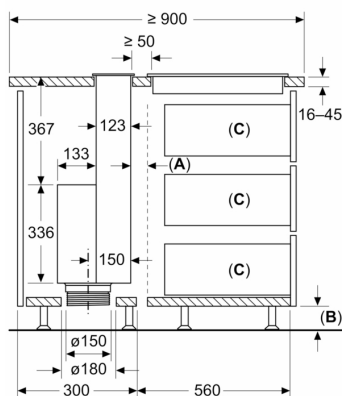

Standard: with worktop divider between downdraft and hob

- A:** Ventilation gap for hob
- B:** ≥ 60 mm for air recirculation
 ≥ 100 mm for air extraction with ducting in the plinth
- C:** Max. pull-out depth
- Motor unit must always be accessible

Measurements in mm
Seamless, top-mounted installation

(Special accessory required)

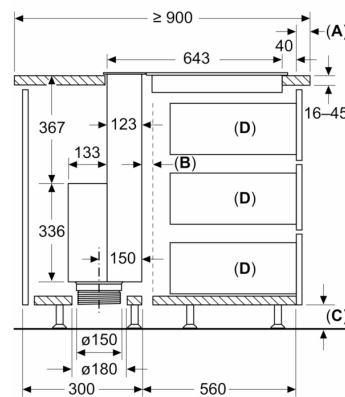

- A:** Worktop overlap to kitchen cabinet
- B:** Ventilation gap for hob
- C:** ≥ 60 mm for air recirculation
 ≥ 100 mm for air extraction with ducting in the plinth
- D:** Max. pull-out depth
- Motor unit must always be accessible