

Series 6, Integrated Design Hood, 90 cm, clear glass black printed DBB97AM60B



B

Perfectly integrated design hood for flush installation and optimal usage of space inside your cupboard.

- **High extraction rate - for continuously clean air in the kitchen.**
- **Expanded storage space: the hood can hold up to 10 kg on each side.**
- **Glass panel with integrated TouchSelect control: an automatic recognition of the glass panel position enables automatic operation of power level and light.**
- **Easy to clean: thanks to the well thought-out design, such as smooth surfaces, the hood is easy to clean.**
- **Intensive speed setting: removes strong kitchen odours quickly and effectively.**

- DWZ0IT0P0 Long Life odor filter (replacement)
- DWZ1IB6K1 Chimney extension 450-854 mm
- DWZ1IB6N1 Chimney extension 187-360 mm
- DWZ1IT1D1 Long Life recirculation kit external
- DWZ1IX1B6 Clean Air Plus odor filter (replacement)
- DWZ1IX1C6 Clean Air Plus recirc. kit external
- DWZ6IB1B4 Clean Air Standard odor filter (repl.)
- DWZ6IB1I4 Clean Air Standard recirculation kit

Typology: Built-in/Built-under
 Length electrical supply cord: 130.0 cm
 Min. required niche size for installation (HxWxD): 340mm x 860.0mm x 300mm mm
 Minimum distance above an electric hob: 430 mm
 Minimum distance above a gas hob:650 mm
 Net weight: 10.4 kg
 Type of control:Electronic
 Number of speed settings: 3-stages + intensive setting
 Max. air extraction:460 m³/h
 Boost position output recirculating:652 m³/h
 Max. air recirculation: 451 m³/h
 Boost position air extraction: 749 m³/h
 Maximum Air flow:460 m³/h
 Number of lights: 3
 Noise level:63 dB(A) re 1pW
 Diameter of air outlet: 120 / 150 mm
 Grease filter material: Washable stainless steel
 EAN code:4242005297955
 Connection rating: 259 W
 Voltage: 220-240 V
 Frequency: 50 Hz
 Plug type: GB plug
 Installation typology: Built-in



Series 6, Integrated Design Hood, 90 cm, clear glass black printed DBB97AM60B

Perfectly integrated design hood for flush installation and optimal usage of space inside your cupboard.

Variant

- 90 cm wide
- Installation: Cupboard 90 cm
- Suitable for ducted or recirculating operation
- For recirculated extraction various recirculation kits are available as optional accessories.

Design

- Flush-fitted installation for a seamless integration in wall cupboards.
- Space efficient compact design for extra storage possibilities on the hood, up to max. 10 kg storage weight per side.
- Glass panel with touch control for an easy operation and enhanced vapor capture.
- Extraction and lighting are automatically turned on and off by opening and closing the glass panel.
- Lighting can also be turned on and off when the glass panel is closed by quick hand touch on control panel.
- Includes mats for hood storage areas, protection against scratches and to help prevent items moving in this space.

Features

- Electronic control via TouchControl
- 3 power levels & intensive setting
- Softlight dimmer function
- 3 x 2 W LED lights
- Colour Temperature: 3500 K
- Light Intensity: 517 lux
- Automatic intensive revert
- Automatic intensive revert (6mins)
- Steel filter cover
- 2 removable metal grease filter cassettes
- Easy to clean smooth surfaces and materials.

Performance

- Extraction rate according to EN 61591 ø 15 cm:
 - max. Normal use: 460 m³/h
 - Intensive: 749 m³/h
- Noise level according to EN 60704-3 and EN 60704-2-13 exhaust air:
 - Max. normal use: 63 dB(A) re 1 pW
 - Intensive: 73 dB(A) re 1 pW
- Noise max. Normal Level: Noise, max. speed in normal use: 63 dB dB*
- With the Clean Air Plus recirculation kit (available as optional accessory) your appliances reaches:
 - Extraction rate in recirculation mode: Max. normal use: 451 m³/h
 - Intensive: 652 m³/h
 - Noise level in recirculation mode: Max. normal use: 67 dB(A) re 1 pW
 - Intensive: 74 dB(A) re 1 pW

Planning and installation information

- Installation system: IDH comfort installation
- Suitable for installation in bottomless wall cupboards.
- Enclosed spacers for installation in wall cupboards with maximum depth of up to 360mm.
- For installation in higher wall cupboards chimney extensions are available as optional accessories.
- Chimney extensions are compatible with the available recirculation kits.
- Dimensions (HxWxD): 340 x 897 x 298 mm
- Built-in dimensions (HxWxD): 340 x 860 x 300 mm
- Diameter pipe Ø 150 mm (Ø 120 mm enclosed)
- Back-pressure flap: Yes
- Electrical cable length 1.3 m
- Please reference the built-in dimensions provided in the installation drawings

Consumption Data

- Energy Efficiency Class: B (at a range of energy efficiency classes from A+++ to D)
- Average Energy Consumption: 64.7 kWh/year*
- Blower Efficiency Class: B*
- Lighting Efficiency Class: A*
- Grease Filtering Efficiency Class: B*
- Power rating: 259 W

* In accordance with the EU-Regulation No 65/2014

**Series 6, Integrated Design Hood, 90 cm, clear glass black printed
DBB97AM60B**

measurements in mm
Front view

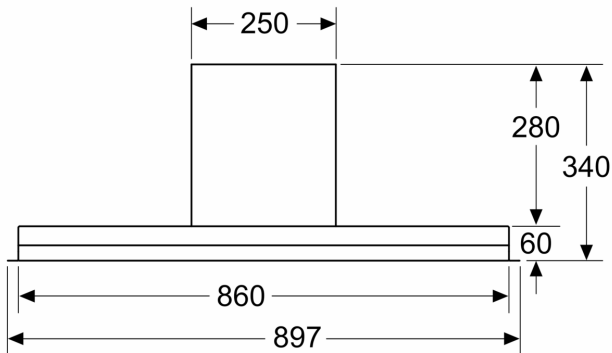

measurements in mm
Installation example

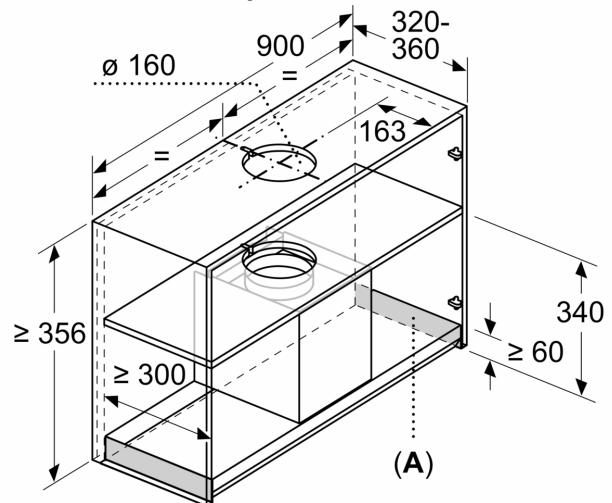

A: Area without hinges

measurements in mm

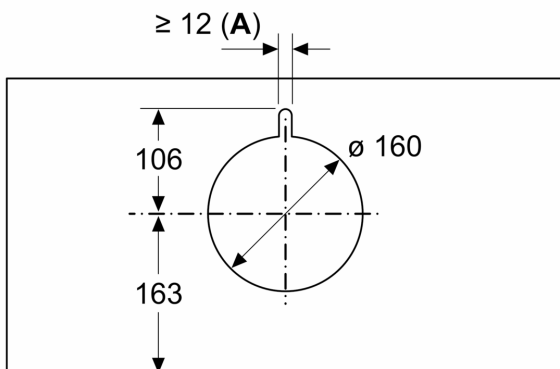

A: Cable bushing

measurements in mm

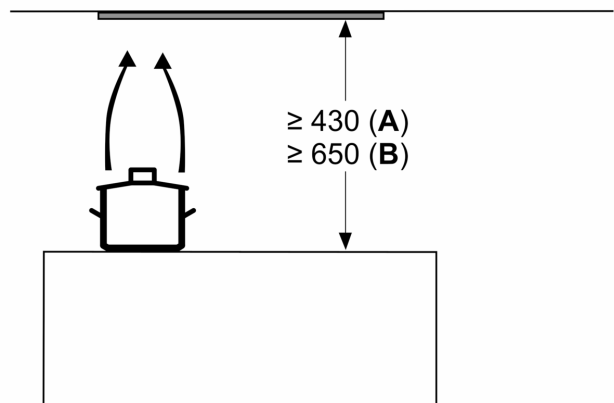

from upper edge of pan support
A: min. 430 electric
B: min. 650 gas

measurements in mm
side view

