

Dual Fuel Freestanding Range
PRD48NLSGC



PRD48NLSGC

INNOVATION

- The only range in the market with a steam and convection combination oven, plus a full-size convection oven and a warming drawer
- 27 Easy Cook® food programs. Pre-programmed modes automatically set the oven temperature and humidity to ensure perfect cooking results
- Patented Pedestal Star® Burner with QuickClean Base® designed for easy surface cleaning and superior heat spread for any size pan
- Powerful 22,000 BTU (NG) burner (front right)
- Precision simmering capabilities as low as 100°F (375 BTU) with 4 ExtraLow® Simmer burners
- SoftClose® hinges for ultra smooth closing of both ovens and the warming drawer.
- Glass surface warming drawer

PERFORMANCE

- 18,000 BTU (NG) Star® Burners
- Superior grilling results, 2000 watt electric grill
- 1.4 cu.ft. steam cavity easily accommodates a 14lb. Turkey
- Large oven 5.7 cu.ft.-accommodates commercial sheet pan plus 2.5 cu.ft. in small oven
- Steam cavity is non-plumbed, for easy installation into any home
- Steam Clean function helps keep the steam oven spotless
- Electronic oven display interfaces to cook timer, CookControl™ meat probe and preheat status with audible alert
- Third Element Convection offers precise airflow for cooking on multiple levels without flavor transfer
- Powerful, 4000 Watt 8-pass broil elements in large oven
- Full Access® telescopic rack, with integrated easy-grip handle
- Spacious 1.1 cu. ft. warming drawer holds up to ten 11" dinner plates
- Drawer has open sides for easy and convenient access
- Star-K Kosher certified

DESIGN

- Distinctive three door design showcases Thermador's self-assured bold and elegant design
- Pinhole and panel lighting concepts provide functional and stylish aesthetics
- Professional style, continuous cast iron grates
- Continuous porcelain, easy to clean cooking surface
- Hidden bake element makes clean-up one smooth surface
- Large oven door window for maximum viewing

Optional accessories

PA12CHPBLK 12" Professional Chopping Block Acc

PA12LCVRN 12" Professional Grill Cover Accessory

PA48.II BSG Low Back for 48" Ranges w/ Steam Oven

**Dual Fuel Freestanding Range
PRD48NLSGC**

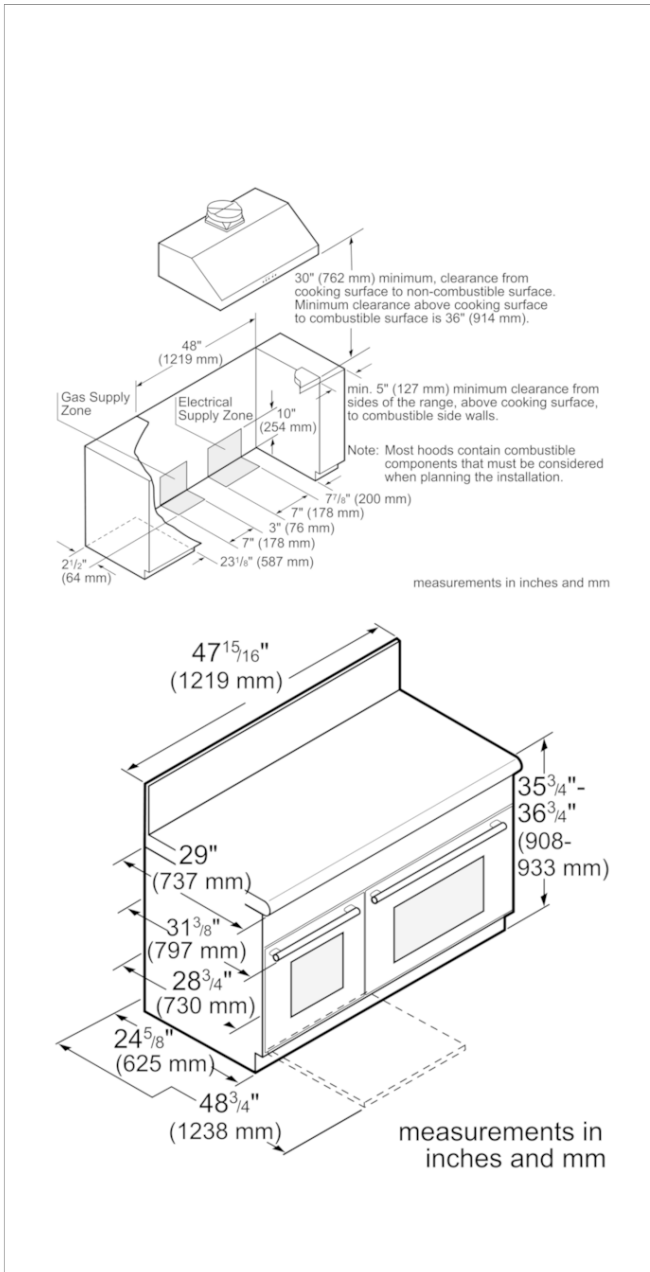

Product Features

- Construction type:** Freestanding
- Product color:** Stainless steel
- Power cord length (cm):** 137
- Net weight (kg):** 249.345
- Gross weight (kg):** 254.0

Consumption and connection features

- Energy efficiency class (2010/30/EC):**
- Energy consumption per cycle conventional (2010/30/EC):**
- Energy consumption gas oven per cycle conventional (2010/30/EC):**
- Energy consumption per cycle forced air convection (2010/30/EC):**
- Energy consumption gas oven per cycle forced air convection (2010/30/EC):**
- Energy efficiency index (2010/30/EC):**
- Watts (W):**
- Current (A):** 50
- Volts (V):** 240/208
- Frequency (Hz):** 60
- Connecting cable type:**
- Plug type:** 240V-4 prong

2019-11-23