

Dual Fuel Freestanding Range, Stainless steel
PRD364NLGC



PRD364NLGC

INNOVATION

- Patented Pedestal Star® Burner with QuickClean Base® designed for easy surface cleaning and superior heat spread for any size pan
- Powerful 22,000 BTU (NG) burner (front right)
- Precision simmering capabilities as low as 100°F (375 BTU) with 4 ExtraLow® Simmer burners
- SoftClose® hinges for ultra smooth closing of the oven door
- Superfast 2-hour self-clean mode - fastest in the industry

PERFORMANCE

- 18,000 BTU (NG) Star® Burners
- Fusion coating surface non-stick, non-PTFE, rust-proof cast-aluminum removable griddle
- Electronic oven display interfaces to cook timer, CookControl™ meat probe and preheat status with audible alert
- Powerful, 8-pass bake and broil elements
- Third Element Convection offers precise airflow for cooking on multiple levels without flavor transfer
- Large oven 5.7 cu.ft.-accommodates commercial sheet pan
- Full Access® telescopic rack, with integrated easy-grip handle
- Six rack levels for multiple item cooking
- Star-K Kosher certified

DESIGN

- Bold Professional design
- Pinhole and panel lighting concepts provide functional and stylish aesthetics
- Restaurant style metal knobs
- Professional style, continuous cast iron grates
- Continuous porcelain, easy to clean cooking surface
- Large oven door window for maximum viewing
- Powerful halogen lighting illuminates the oven cavity
- Hidden bake element makes clean-up one smooth surface
- Signature blue indicator lighting

Optional accessories

PA12CHPBLK 12" Professional Chopping Block Acc
PA12LCVRN 12" Professional Grill Cover Accessory
PA36JLBG 36" Low Backguard for Pro Grand Ranges
PA36JTKG 36" Toe Kick for Pro Grand Ranges
PABRICKBKN Bk Briquettes and Basket for Pro Grill
PAGRIDDLE Professional Griddle Accessory
PAGRIDDLEN Pro Griddle Accessory for Grill Module
PAKNOBLUNG Blue Knob Kit for Pro Grand Ranges

Included accessories

1 x nozzle set for liquid gas, 1 x temperature sensor, 1 x telescopic rack, 1 x grill plate, 1 x Broiler pan, 1 x island trim

825225908296

**Dual Fuel Freestanding Range, Stainless steel
PRD364NLGC**

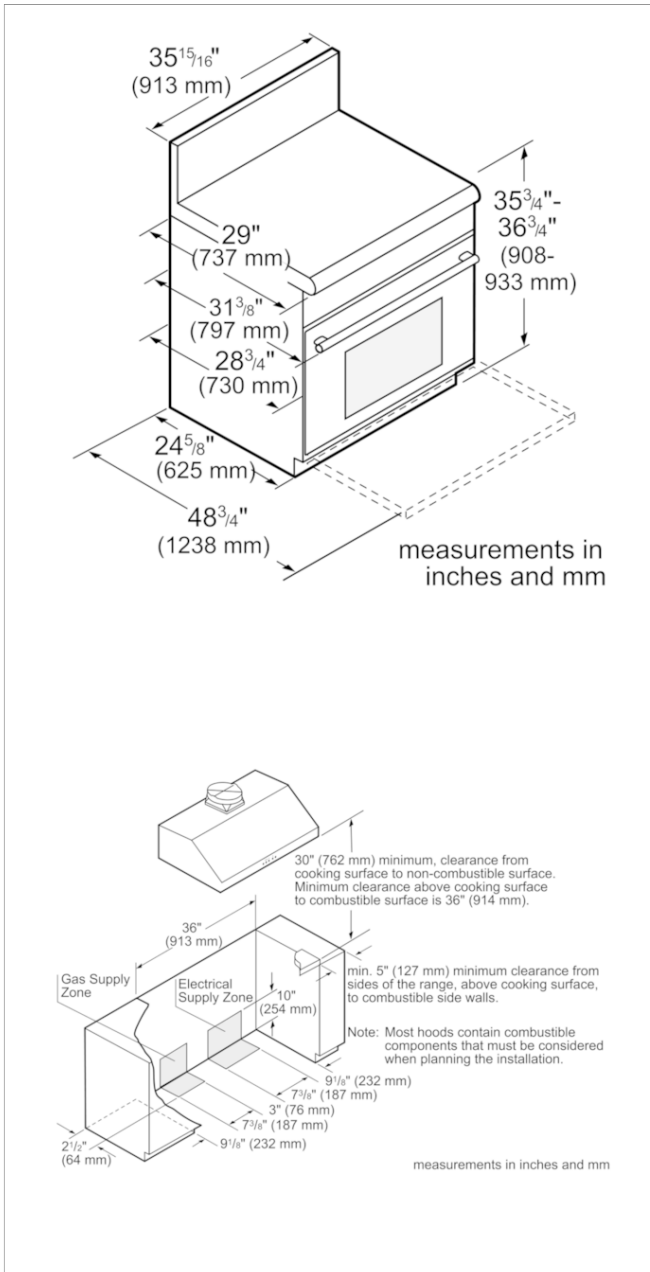

Product Features

- Total number of cooktop burners: 4**
- Cooking mode: Centre-area grill/broiler, Convection Bake, Selfcleaning pyrolytic, Small hot air grill, Top/bottom heat, Warming**
- Integrated Cleaning system: Self Clean**
- Type of control: Electronic**
- Knob Material: Full metal**
- Included accessories: 1 x nozzle set for liquid gas, 1 x temperature sensor, 1 x telescopic rack, 1 x grill plate, 1 x Broiler pan, 1 x island trim**
- Sealed Burners: Yes**
- Number of Double grates: 2**
- Bake Element Wattages cavity 1 (W): 2000**
- Broil Element Wattages cavity 1 (W): 4000**
- Convection Element Wattages cavity 1 (W): 2750**
- Number of gas burners: 4**
- Location of 1st heating element: front left**
- Location of 2nd heating element: center left**
- Location of 3rd heating element: back left**
- Power of 3rd burner (BTU): 18000**
- Location of 4th heating element: middle back**
- Location of 5th heating element: back right**
- Power of 5th burner (BTU): 18000**
- Location of 6th heating element: center right**
- Safety device: automatic reignition, Overheating protection, Safety valve, Thermostat**

Consumption and connection features

- UPC code: 825225908296**
- Product color:**
- Gas type: Natural gas 15 mbar (USA)**
- Alternative gas type: Liquid gas 27,5 mbar (USA)**
- Natural Gas Connection Rating (BTU): 76000**
- Watts (W):**
- Current (A): 50**
- Volts (V): 240/208**
- Frequency (Hz): 60**
- Approval certificates: CSA**
- Required cutout size (HxWxD) (in): 36" width slide-in**
- Overall appliance dimensions (HxWxD) (in): 35 7/8" x 35 15/16" x 28 7/8"**
- Variable cooker height (in): 7/8"**
- AHAM volume (of cavity) - cavity 1: 4**
- Product packaging dimensions (HxWxD) (in): 45" x 40" x 36"**
- Net weight (lbs): 395**
- Gross weight (lbs): 408**

2019-11-23