

**iQ800, heat pump dryer, 9 kg
WT47Y7W0AU**



WZ11410	Stacking kit
WZ20400	Stacking kit with pull-out shelf

iSensoric Premium 'Green Technology' heat-pump dryer with selfCleaning condenser and Fast Drying capability

- ✓ selfCleaning condenser: cleans itself automatically
- ✓ Sensor-controlled autoDry technology prevents laundry from shrinking when being dried.
- ✓ Special drying programme for functional textiles such as sportswear and outdoor clothing.

Technical specifications

Built-in / Free-standing:	Freestanding
Removable top:	No
Door type:	Right reversible
Length electrical supply cord:	145.0 cm
Dimensions (HxWxD):	842x598x599 mm
Net weight:	56.0 kg
Fluorinated greenhouse gases:	No
Hermetically sealed equipment:	Yes
EAN code:	4242003699348
Power supply:	1000 W
Fuse protection:	10 A
Voltage:	220-240 V
Frequency:	50 Hz
Capacity:	9.0 kg
Energy efficiency rating:	A+++
Energy consumption electric dryer, full load - NEW (2010/30/EC):	1.46 kWh
Standard cotton programme time at full load:	148 min
Energy consumption electric dryer, partial load - NEW (2010/30/EC):	0.82 kWh
Standard cotton programme time at partial load:	94 min
Weighted annual energy consumption, electric dryer - NEW (2010/30/EC):	176.0 kWh/year
Weighted programme time:	117 min
Average condensation efficiency full load (%):	87 %
Average condensation efficiency partial load (%):	89 %
Weighted condensation efficiency (%):	88 %



iQ800, heat pump dryer, 9 kg WT47Y7W0AU

Capacity

- 9 kg capacity

Consumption rates

- 8 Energy Stars

Programmes

- Cottons and Easy Care, Mixed Load, Ultimate woolCare system with drying basket, Outdoor Program, Towels, Quilt, Timed program warm, Timed program cold, Hygiene/Allergy Plus, Lingerie, Super Quick 40 minutes program, Shirts/blouses

Performance

- activeAir technology
- Sensor drying, monitors the temperature and moisture content to ensure garments are dried to the desired setting
- Sensitive drying system for soft and even drying of clothes
- Automatic Self-Cleaning System keeps the condenser lint-free, ensuring the same energy performance every time
- Anti crease cycle 120 min at the end of the programme
- AntiVibration design: for greater stability and quietness

Convenience

- 2 time-based programs
- Child-proof lock
- Glass door with 180 ° opening angle
- Large and easily accessible lint filter

Design

- Illuminated control dial with integrated On-/Off mode
- TFT- Clear text display for easy use
- LED drum interior light

Technical Information

- Dimensions (H x W x D): 84.2 cm x 59.8 cm x 59.9 cm (63.4 cm including door handle)

**iQ800, heat pump dryer, 9 kg
WT47Y7W0AU**

Measurements in mm

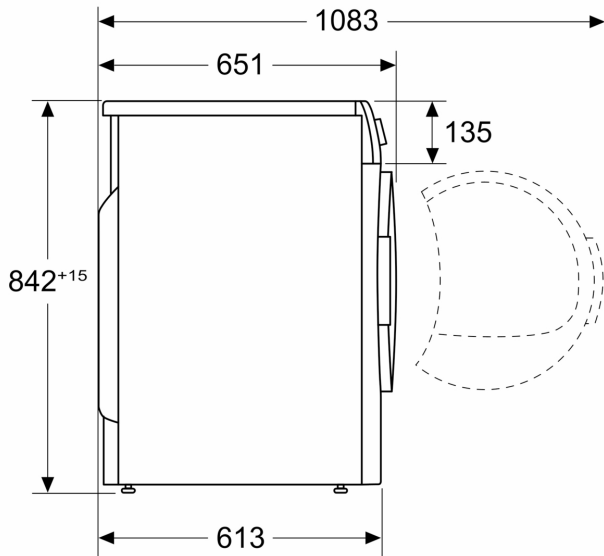

Measurements in mm

