

**iQ500, built-in freezer, 177.2 x 55.8 cm, flat hinge
GI81NAE30M**



freezer with electronic temperature control in the very efficient EEC A++.

- ✓ A++ energy class refrigerator consumes %40 less energy than A energy class.
- ✓ noFrost technology prevents icing and frosting so you never have to defrost again.
- ✓ All freezer drawers and glass shelves can be removed easily. varioZone lets you organize the space flexibly.

Energy Efficiency Class (Regulation (EU) 2017/1369): F
Average annual energy consumption in kilowatt hour per year (kWh/a) (EU) 2017/1369: 294 kWh/annum
Sum of volume of frozen compartments (EU 2017/1369): 212 l
Airborne acoustical noise emissions (EU 2017/1369):	... 36 dB(A) re 1pW
Airborne acoustical noise emission class (EU 2017/1369): C
Type: Upright freezer
Installation type: Built-in
Frost free system: Fridge and freezer
Climate class: SN-T
Door panel options: Not possible
Width of the appliance: 558 mm
Depth: 545 mm
Dimensions of the packed product (HxWxD):	. 1840 x 610 x 640 mm
Warning signal / malfunction: Both visual and audible
Defrost: Automatic
Cover door installation system: Fixed-mounted
Number of drawers/baskets (Stck): 5
Number of freezing flaps (Stck): 2
Lockable door: No
Thermometer freeze section: Digital
Light: No
Length electrical supply cord: 230.0 cm
Door opening: Left reversible
Net weight: 65.3 kg
Gross weight: 70.0 kg
Multi-Flow Air Tower: No
Number of compressors: 1
Number of independent cooling systems: 1
Economy setting: No
Fast freezing switch: Yes
Door bin adjustability - Freezer: No
Tilt-out door bins in freezer: No
Number of shelves - Freezer: 0
Door bin adjustability - Freezer: No
Shelf Material - Freezer: Safety glass
Reversible Door Hinge: Yes
Connection rating: 120 W
Fuse protection: 13 A
Frequency: 50 Hz
Door panel options: Not possible
Installation typology: Full-integrated
Noise level: 36 dB(A) re 1pW
Energy Star Qualified: No
Plug type: GB plug
Required cutout/niche size for installation (in): x
Dimensions of the packed product: 72.45 x 24.01 x 25.19
Net weight: 144.000 lbs
Gross weight: 154.000 lbs
Included accessories: 2 x cold1

accumulator, 1 x ice cube tray



iQ500, built-in freezer, 177.2 x 55.8 cm, flat hinge GI81NAE30M

- noFrost, Built-in upright-freezer (> 90 cm height)

Performance and consumption

- Total capacity: 235 litres
- Freezer capacity: 235 litres

Design

- Flat hinge
- Integrated, Flat hinge

Comfort and Safety

- noFrost
- 7 segment electronic control
- Automatic deactivation
- Acoustic warning system, Optical warning system

Freezer Section

- Freezing capacity: 20 kg in 24 hours
- 5 transparent freezer drawers
- Safety glass
- Storage time in power failure: 22 Hours

Dimensions

- Dimensions: H 177.2 cm x L 55.8 cm x D 54.5 cm
- Niche Dimension H X W x D: 177.5 cm cm x 56 cm x 55 cm

Technical Information

- Door left hinged, reversible Door
- Rated Voltage 220 - 240 V
- Connection load: 120 W
- Climate Class SN-T

Accessories

- 2 x cold accumulator, 1 x ice cube tray

Country Specific Options

- Gross capacity, total: 235 l
- Gross capacity**** freezer: 235 l (-18°C and below)
- Based on the results of the standard 25-hour test. Actual consumption depends on usage/position of the appliance.

Main Features

Environment and Safety

Dimension and installation

- Built-in upright-freezer (> 90 cm height)
- Airborne acoustical noise emissions: 36 dB dB(A) re 1 pW
- 7 segment electronic control (Digital readout)

ACCESSORIES

iQ500, built-in freezer, 177.2 x 55.8 cm, flat hinge
GI81NAE30M

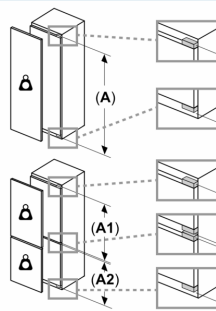
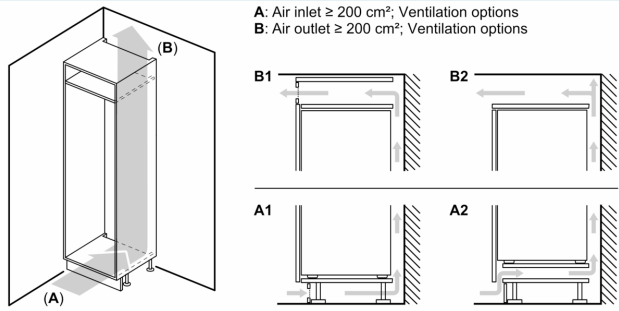

Maximal permissible weight of the unit fronts

Fitted unit fronts that exceed the permissible weight may cause damage and result in functional impairment of the hinges

Δ Weight

A: Appliance door height including hinges in mm

B: Undamped hinge, unit front in kg

C: Damped hinge, unit front in kg

D: Additional possible load in kg with heavy load kit

A	B	C	D
1500-1750	22	22	B+5 / C+5
720-1400	19	19	
A1	15	19	
A2	15	19	