

## iQ300, electric hob, 60 cm, Black, ET675LNV1M

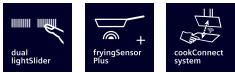

- ✓ Dual lightSlider lets you easily and intuitively operate the cooktop.
- ✓ The fryingSensor plus controls the temperature in the pan so can never burn again.
- ✓ The timer with switch-off function safely shuts off the cooking zone when the selected cooking time expires.
- ✓ Control different functions of your hood, like power level or light, directly from your cooktop (with matching hood) - cookConnect system.
- ✓ Space for large pots and pans thanks to the 21 cm two-ring cooking zone.

HZ32WA00	Wireless food thermometer
HZ390090	Wok Set consisting of 3 Items
HZ390230	System pan diameter 21cm
HZ394301	Connecting strip
HZ95E030	Set of 2 pots and 1 pan

Product name/family: ..... Cooking zone ceramic  
 Installation type: ..... Built-in  
 Type of heating: ..... Electric hob  
 Total number of positions that can be used at the same time: 4  
 Min. required niche size for installation (HxWxD): ....45 x 560-560 x 500-500 mm  
 Width of the appliance: ..... 602 mm  
 Dimensions: .....45 x 602 x 520 mm  
 Dimensions of the packed product (HxWxD): ... 100 x 750 x 590 mm  
 Net weight: ..... 8.3 kg  
 Gross weight: ..... 9.1 kg  
 Residual heat indicator: ..... Separate  
 Location of control panel: ..... Front  
 Basic surface material: ..... Ceramic  
 Color of surface: ..... Black, Alu, brushed  
 Sealed Burners: ..... No  
 heating with booster: ..... Front left  
 Power of heating element (kW): ..... 2 kW  
 Power of 3rd heating element (kW): ..... 1.8 ; 2.6 kW  
 Power of 5th heating element (kW): ..... 1.2 kW  
 Power of heating element (kW in boost): ..... [2.3] kW  
 Connection rating: ..... 7800 W  
 Voltage: ..... 220-240 V  
 Frequency: ..... 60; 50 Hz  
 Type of heating: ..... Electric hob  
 Plug type: ..... no plug  
 Appliance Dimensions (h x w x d) (in): ..... x x  
 Dimensions of the packed product: ..... 3.93 x 23.22 x 29.52  
 Net weight: ..... 18.000 lbs  
 Gross weight: ..... 20.000 lbs  
 Total number of positions that can be used at the same time: 4  
 Min. required niche size for installation (HxWxD): ....45 x 560-560 x 500-500 mm  
 Dimensions: .....45 x 602 x 520 mm  
 Dimensions of the packed product (HxWxD): ... 100 x 750 x 590 mm  
 Net weight: ..... 8.3 kg  
 Gross weight: ..... 9.1 kg



## iQ300, electric hob, 60 cm, Black, ET675LNV1M

measurements in mm

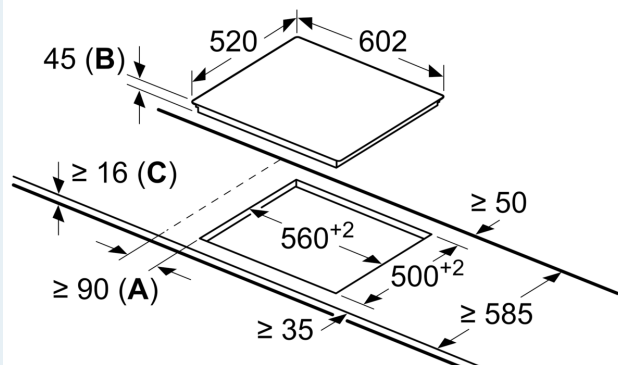

**A:** Minimum distance from the hob cut-out to the wall.

**B:** Recessed depth

**C:** With fitted oven underneath min. 20, possibly more; see space requirements for the oven.