

**iQ100, electric hob, 60 cm, Black, ET611FEB8M**

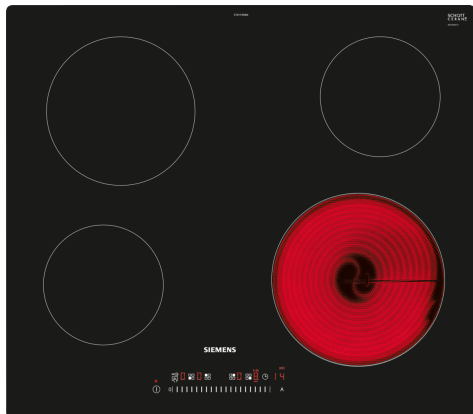

- ✓ touchSlider control allows to control the temperature by entering it directly or by moving the slider with a single finger.
- ✓ The timer with switch-off function safely shuts off the cooking zone when the selected cooking time expires.
- ✓ The child safety lock safely prevents unintentional switch-on.
- ✓ For more energy efficient cooking - energy consumption display.

HZ32WA00 Wireless food thermometer  
 HZ9FE280 Iron pan Ø 18 / 28 cm  
 HZ9SE030 Set of 2 pots and 1 pan

Product name/family: ..... Cooking zone ceramic  
 Installation type: ..... Built-in  
 Type of heating: ..... Electric hob  
 Total number of positions that can be used at the same time: 4  
 Min. required niche size for installation (HxWxD): ....45 x 560-560 x 490-500 mm  
 Width of the appliance: ..... 592 mm  
 Dimensions: ..... 45x592x522 mm  
 Dimensions of the packed product (HxWxD): ... 100 x 750 x 590 mm  
 Net weight: ..... 7.6 kg  
 Gross weight: ..... 8.3 kg  
 Residual heat indicator: ..... Separate  
 Location of control panel: ..... Front  
 Basic surface material: ..... Ceramic  
 Color of surface: ..... Black  
 Length electrical supply cord: ..... 100.0 cm  
 Sealed Burners: ..... No  
 Power of heating element (kW): ..... 1.2 kW  
 Power of 3rd heating element (kW): ..... 2 kW  
 Power of 5th heating element (kW): ..... 1.2 kW  
 Connection rating: ..... 6600 W  
 Voltage: ..... 220-240 V  
 Frequency: ..... 50; 60 Hz  
 Type of heating: ..... Electric hob  
 Plug type: .....no plug  
 Appliance Dimensions (h x w x d) (in): ..... x x  
 Dimensions of the packed product: ..... 3.93 x 23.22 x 29.52  
 Net weight: ..... 17.000 lbs  
 Gross weight: ..... 18.000 lbs  
 Total number of positions that can be used at the same time: 4  
 Length electrical supply cord: ..... 100.0 cm  
 Min. required niche size for installation (HxWxD): ....45 x 560-560 x 490-500 mm  
 Dimensions: ..... 45x592x522 mm  
 Dimensions of the packed product (HxWxD): ... 100 x 750 x 590 mm  
 Net weight: ..... 7.6 kg  
 Gross weight: ..... 8.3 kg



## iQ100, electric hob, 60 cm, Black, ET611FEB8M

- 60 cm: space for 4 pots or pans.

### Flexibility of cooking zones

### Usage convenience

### Design

- Frameless design

### Safety

### Installation

- Dimensions of the product (HxWxD mm): 45 x 592 x 522
- Required niche size for installation (HxWxD mm) : 45 x 560 x (490 - 500)
- Min. worktop thickness: 16 mm
- Connected load: 6.6 KW
- Power cord: 1 m, loose insert in packaging

**iQ100, electric hob, 60 cm, Black,  
ET611FEB8M**

measurements in mm

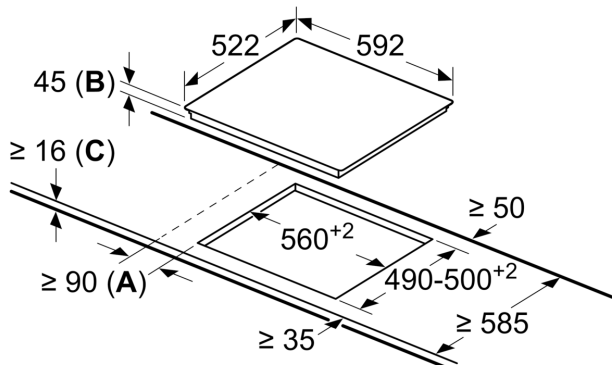

- A:** Minimum distance from the hob cut-out to the wall.
- B:** Recessed depth
- C:** With fitted oven underneath min. 20, possibly more; see space requirements for the oven.