

**Series 6, built-in microwave
BFL524MS0M****Included accessories**

1 x Turntable

**The built-in microwave for the 38 cm niche:
use it for thawing, heating and perfect
preparation of foods.**

- **AutoPilot 7:** every dish is a perfect success thanks to 7 pre-set automatic programmes.
- **Pop-out controls:** for an easy to clean front.
- **Stainless steel interior:** easy to clean interior thanks to smooth surfaces and no sharp edges.
- **Electronical door opening:** comfortable door opening just with a fingertip on the sensor button.
- Triple Distribution Turntable Disk - provides improved distribution of microwave energy for more even cooking.

Technical Data

Type of micro-wave oven : MW only

Type of control : Electronic

Color / Material Front : Stainless steel

Dimensions : 382 x 594 x 317 mm

Cavity dimensions : 201.0 x 308.0 x 282.0 mm

Length electrical supply cord : 130.0 cm

Net weight : 16.2 kg

Gross weight : 18.2 kg

Maximum micro-wave power : 800 W

Number of Power Levels : 5

Turntable : Yes

Cavity material : Stainless steel

Door opening : Button

Clock : Yes

Included accessories : 1 x Turntable

Main colour of product : Stainless steel

Height of the appliance : 382 mm

Width of the appliance : 594 mm

Depth of the product : 317 mm

Maximum micro-wave power : 800 W

Connection Rating : 1270 W

Fuse protection : 10 A

Voltage : 230-240 V

Frequency : 50 Hz

Plug type : GB plug

Color / Material Front : Stainless steel

Required cutout/niche size for installation (in) : x x

Dimensions of the packed product : 16.92 x 15.15 x 25.19

Net weight : 36.000 lbs

Gross weight : 40.000 lbs

Included accessories : 1 x Turntable



4 242005 038756

Series 6, built-in microwave BFL524MS0M

**The built-in microwave for the 38 cm niche:
use it for thawing, heating and perfect
preparation of foods.**

Microwave and Heating System

- Cavity volume: 20 l

Design:

- stainless steel cavity

Comfort:

- LED
- electronic clock
- User-friendly electronics: extremely easy and comfortable operation
- automatic programming, 7
- 4 defrost and 3 cooking programmes in microwave function
- memory function (1 setting)
- LED light
- Turn table 25.5 cm Glass
- side opening door, hinge left

Accessory:

- 1 x Turntable

Environment and Safety:

- Safety switch
door contact switch
- Integral cooling fan

Technical Info:

- Length of mains cable: 130 cm
- Total connected load electric: 1.27 KW
- Nominal voltage: 230 - 240 V
- Can be built in a 60 cm wall cupboard (at least 30cm deep)

Dimensions:

- Appliance dimension (hxwxd): 382 mm x 594 mm x 317 mm
- Niche dimension (hxwxd): 362 mm - 365 mm x 560 mm - 568 mm x 300 mm
- "Please reference the built-in dimensions provided in the installation drawing"
- Max. Power: 800 W; 5 Microwave power settings: 90 W, 180 W, 360 W, 600 W, 800 W
- Rotary Control, Pop-out controls, Touch control
- Open Button, electric
- Touch key operation

Series 6, built-in microwave BFL524MS0M

Microwave,
corner installation

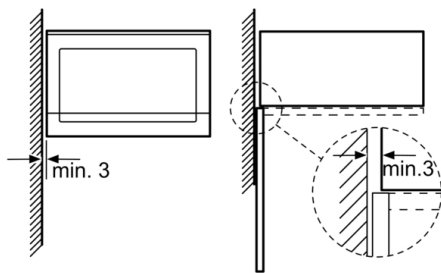

Measurements in mm

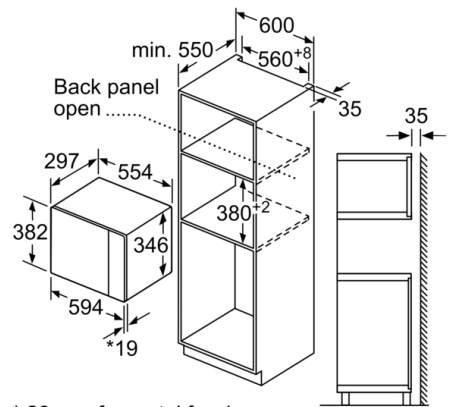
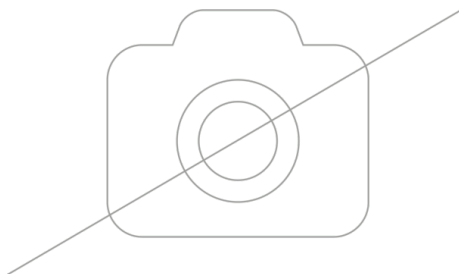
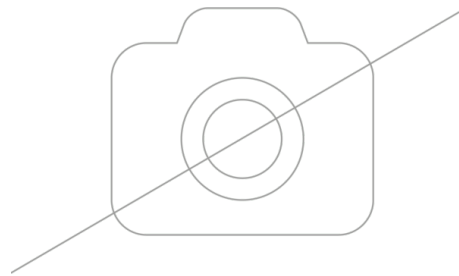

* 20 mm for metal fascia
measurements in mm

measurements in mm

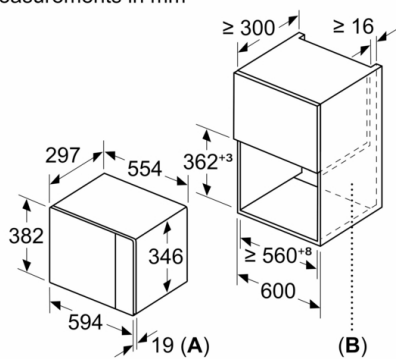

A: 20 mm for metal fascia
B: Back panel open