

Clip-Auszug, Edelstahl
Z13TC16X0

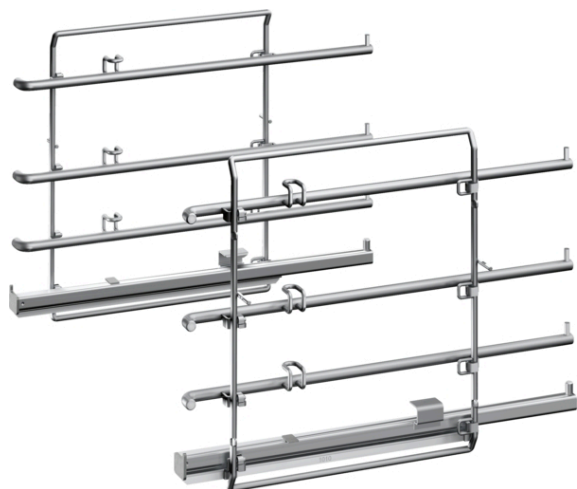

COOKING PASSION SINCE 1877



Ausstattung

Technische Daten

Abmessungen des verpackten Gerätes : 90 x 300 x 410 mm

Abmessung der Palette : 100.0 x 80.0 x 120.0

Anzahl Geräte pro Palette : 50

Nettogewicht : 2,613 kg

Bruttogewicht : 3,0 kg

EAN-Nummer : 4242004193517



4 242004 193517