



SIEMENS



Built-in Appliances

siemens-home.bsh-group.com/za

The future moving in.

Siemens Home Appliances

Technologies that not only improve our everyday life, but our future too



Dishwashers energy labelling

The aim of the energy label of the dishwasher is to reduce energy consumption, while at the same time not having any adverse effect on the cleaning and drying performance of the appliance. Dishwashers, in general, use the Eco50°C programme as its standard programme upon which energy consumption is rated. The energy label for dishwashers comprises 3 classifications namely:

- Energy efficiency
- Cleaning performance
- Drying performance

Washing machines energy labelling

The aim of the energy efficiency label is to offer consumers a standardised method of choosing the most energy efficient appliance, while at the same time offering you the best possible washing results.

Washing machines use the Cotton 60°C programme as its standard programme upon which energy efficiency, washing performance and spin-drying performance levels are rated.

The energy label for washing machines comprises 3 classifications (ranging from "A" to "D" rating) namely:

- Energy efficiency
- Washing performance
- Spin-drying performance

Tumble dryers energy labelling

There is a difference between condensation and vented dryers, with condensation dryers having a lower energy efficiency than vented dryers.

Fridges and freezers energy labelling

Fridges and freezers are the most hardworking appliances in your kitchen as they are on the go 24 hours a day, seven days a week. The energy label is able to provide information about their performance and physical characteristics. These include the annual consumption of energy (in kWh p/a) as well as the storage volume of the compartments (in Litres).

All Siemens cooling appliances, even the entry level models have very efficient energy ratings.

It is important to note that the energy label supplies you with the net volume as opposed to the gross volume of the unit.

This is the usable volume of the fridge as opposed to the overall volume, and can therefore be relatively important when making a decision as to which unit is best for you. Siemens cooling products have been converted to CFC and HFC free materials in 1993 already. This means that the harmful substances previously used in the insulation materials have been replaced with environmentally friendly natural gases which do not damage the ozone layer or increase the harmful greenhouse effect.

Energy efficiency ratings

Energy efficiency labels are informative labels affiliated to manufactured products. These labels are able to indicate a products energy performance in order to provide consumers with the necessary data for making informed purchase decisions. The more efficient a product is the less energy it requires and the more you get for your money. Not only is this saving of electricity good for your wallet, but it is good for the environment too; between 1995 and 2000 there has been a saving of three-quarter million-tons of CO2 alone in Europe, by improving the technique of large household appliances. The energy label ranks the appliance's efficiency from "A+++" to "D".

These are categorised as follows:

Class A+++ to A+ excellent

Class A to B good

Class C to D average

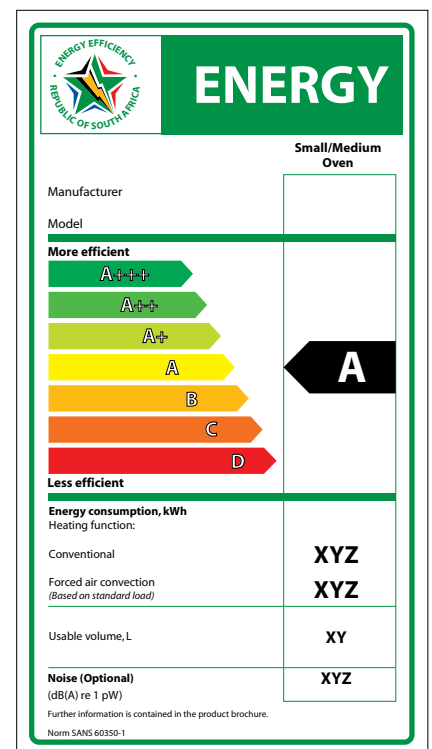
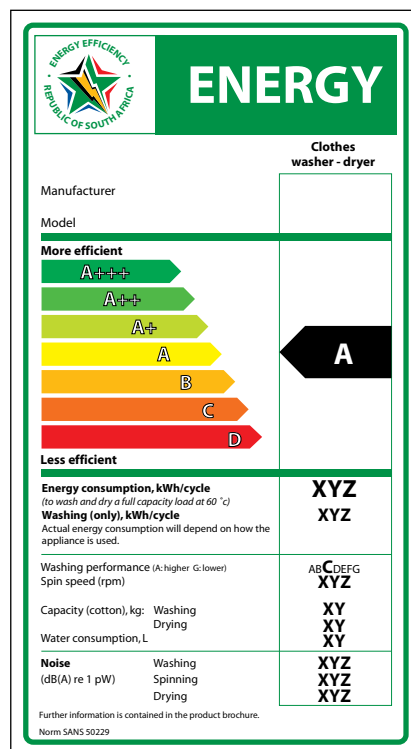
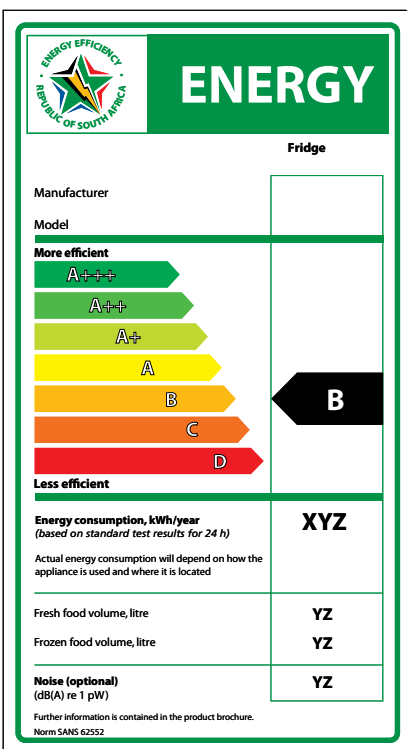
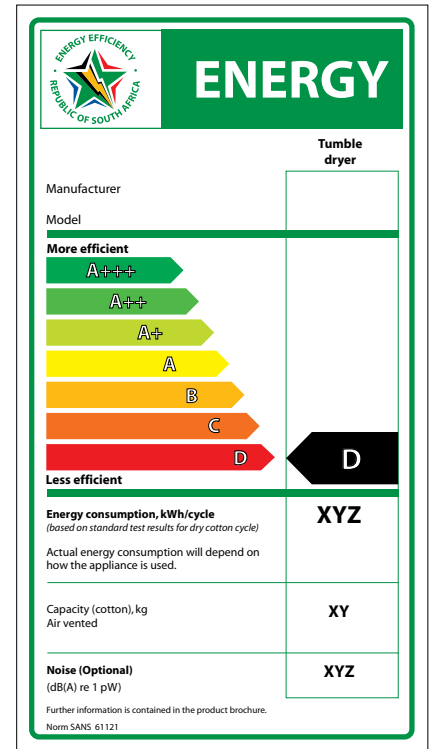
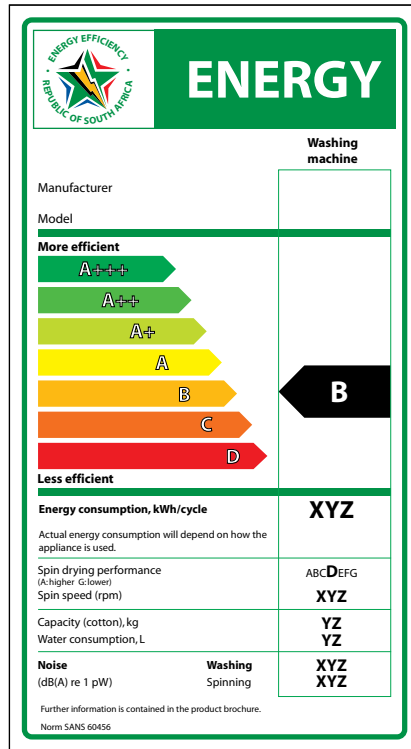
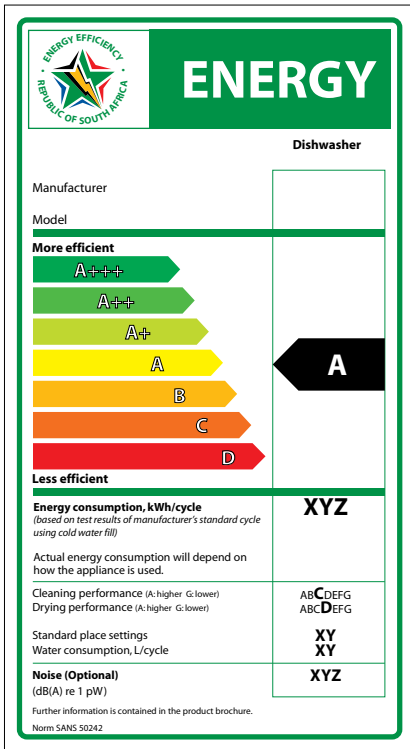

Uncompromising design,
innovation and technology



Ovens	6 – 19
Coffee Machine	20 – 21
Hobs	22 – 35
Extractors	36 – 44
Cooling	45 – 50
Dishwashing	51 – 55
Installation Diagrams	56 – 61
Customer Service	63



Outstanding taste, cooked
in the time you have

varioSpeed saves up to
50% of your time and
allows you to adjust the
cooking time to your
own speed of life.



The iQ700 ovens with varioSpeed

There are things in life that are worth spending more time on like a business meeting, a weekend adventure or getting to read a few more pages of a bedtime story. Whenever you find yourself in a situation where you want to spend your time differently, but not necessarily cooking, varioSpeed allows you to. No matter whether it's a little snack or a masterful salmon recipe, you can now adjust the cooking time to your own speed of life. Ultimately giving you all the flexibility your less ordinary life requires.

Twice as fast in combination: by choosing the integrated microwave function with a conventional cooking option, you can speed up the preparation of your dishes when you need to – without compromising on the quality you would expect. Save up to 50% of your time, to give you the freedom when you require it.

From desserts to roasts and even frozen food, varioSpeed can be conveniently selected to cook a variety of meals when you want to take your time on other things. For even more flexibility; cooking, reheating or quickly defrosting a meal at the end of the day is fast and efficient thanks to the simultaneous heating using microwaves, and a conventional cooking function such as 4D hot air. Save time in the kitchen when you want to and spend it doing the things you love.

For a life less ordinary.



One oven, many functions. Now it's even easier to cook perfect dishes



Bake Sensor*

The Bake sensor monitors the conditions within the oven and automatically adjusts the baking process. This automatic baking system allows for the preparation of a wide range of baked goods and convenience goods.



Multipoint Temperature Probe*

The Meat probe takes the guess work out of cooking. It measures the temperature of the meat at three separate points for increased accuracy and has a built-in temperature gauge. As the meat probe attaches to the oven, when the core temperature has reached the programmed temperature the oven will switch off. It is ideal when trying to determine the readiness of meat and poultry.



Added Steam function*

Prepare perfectly crispy and juicy dishes with PulseSteam, ideal for adding moisture and avoiding dried out food when reheating. PulseSteam offers more flexibility in just one appliance. Steaming retains the flavour, vitamins and nutrients in food. Vegetables keep their bite, shape and appealing natural colour. They don't just look good. They're also healthy and delicious.



Dish Categories*

Simply select the required dish and enter the weight – the cookControl Plus function immediately provides full colour images with individual recommended settings for perfectly cooking the dish you want. Using cookControl Plus you can achieve the best results for a variety of meals with less to worry about and complete peace of mind.

*Selected models only

Simply the best

Life's pleasures often lie in the simplest things. A philosophy that is essential to the design of the iQ700 ovens with their easy to use clearText TFT display and time saving activeClean® self-cleaning system. Supreme features that mean you can enjoy cooking even more.

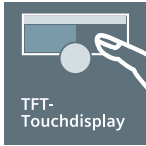

iQ700 Ovens with TFT touchDisplay Plus.*

It's never been this easy to keep an eye on your cooking. Bigger size, brighter colours, higher contrast and better resolution.

And now controllable with the touch of a finger. The new TFT touchDisplay Plus is the most innovative and intuitive user interface available for an oven.

Say goodbye to multiple dials and printed icons, the TFT touchDisplay Plus offers more than just control of your oven. It gives tips and information on each programme, full colour graphics and images, it can even suggest the correct way to cook your dishes with cookControl Plus. Clear to read from any angle, it's advanced yet easy-to-use technology for effortless cooking.

Three types of TFT displays are also now available across the iQ700 oven range. The slightly smaller TFT touchDisplay offers all the functionality of a touchscreen display with crisp text and images.



Smaller still, the TFT Display can be operated with touchControl buttons either side of the screen, yet still has clear programme information. Thanks to the menu structure on all of our ovens, which is optimised for convenient and easy-to-use touch navigation, it's even easier to select the perfect settings.

Designed to serve one purpose: giving you full control.

The easiest way to clean an oven: let the oven clean itself



iQ700 Ovens with activeClean.*

Enjoy preparing food without worrying about the consequences. No matter how creative it gets in the oven interior, you no longer need any chemical treatments to get it clean again – only the push of a button. Hassle-free, the oven cleans itself thoroughly with activeClean. It does so by heating up to very high temperatures – turning all residues into ash, which can easily be wiped away. This process is called pyrolysis and is the most convenient and efficient way to clean the whole interior of your oven.

And now, even the telescopic rails, bars and tray are specially designed to be used with activeClean so you don't need to remove them at all. Only the wire shelf needs to be removed. activeClean makes it possible to forget about the chore of cleaning your oven and gives you back your time to spend on the things you love. For a life less ordinary.



activeClean® – ovens that clean themselves.

Stylish design and intelligent innovation perfectly engineered to meet the demands of today's busy lifestyle. No matter what you're cooking there is a range of functions and features to help you to cook-up the perfect meal.



Hot air grilling*

The hot air grilling system prepares large roasts, such as duckling or goose, with a rotisserie quality. This is done by the grill and fan being switched on and off alternatively (patented interval control mode).



Defrost*

The defrosting heating method is perfect for gentle defrosting of frozen food items.



Large surface grill*

The large surface grill is ideal when you would like to prepare fish, steaks or toast in the oven. It's also suited for au gratin dishes.



Small surface grill*

When you use the small surface grill only the middle part of the grill-heating element is heated. This is the ideal setting for small amounts, e.g. four slices of toast.



Intensive heat*

Intensive heat is ideal for pizza, bread and frozen food because of the unsurpassed strong bottom heat.



Keep warm function*

The keep warm function keeps the correct temperature for a longer period of time. Plates and cups are kept at the correct temperature by means of the preheat function.



An oven door that opens and closes gently and quietly thanks to the intelligent mechanism: softMove*

For a calmer kitchen, softMove offers softer opening and closing of the oven door without having to push and pull. The intelligent dampers ensure that the oven door is left to open and close gently and quietly. Available on all iQ700 built-in ovens.



Everything put in a good light.

Depending on the model, there are different kinds of illumination inside the oven. Whether it's the standard Halogen light, LEDs or the most advanced Multilevel LED strip, they all provide a brilliant view of your dishes without having to open the oven door.



Sabbath setting*

On a day of rest use the oven without having to operate it: With this setting, the oven maintains a temperature of between 85C and 140C for up to 73 hours. You can eat thus warm food on the Sabbath, without operating the oven

*Selected models only



Model	VB554DFR0	VB554CCR0
Product description	iQ500 90 cm built-in oven	iQ500 90 cm built-in oven
Heating methods	Bottom heat, Circulating air, Top/bottom heat, Top/bottom heat gentle, Full width grill, Hot air grilling, Hot Air, Rotisserie	Bottom heat, Circulating air, Top/bottom heat, Top/bottom heat gentle, Full width grill, Hot air grilling, Hot Air, Rotisserie
Comfort and safety	Oven capacity: 112 Litres Temperature range 30°C-250°C Electronic clock Oven interior light – 2 elongated halogen lights Integral cooling fan Child lock Automatic switch off	Oven capacity: 85 Litres Temperature range 30°C-250°C Electronic clock Oven interior light – 2 elongated halogen lights Integral cooling fan Child lock Automatic switch off
Design	Pop-out controls, touch controls Oven cavity with removable rack supports 1-fold telescopic rail, level independent	Pop-out controls, touch controls Oven cavity with removable rack supports 1-fold telescopic rail, level independent
Cleaning	Catalytic side liners and back panel Full glass inner door	Catalytic side liners and back panel Full glass inner door
Accessories	1 x Enamel baking tray 1 x Combination grid 1 x Universal pan	1 x Combination grid 1 x Universal pan
Product specs	Overall (H x W x D): 59.4 x 89.6 x 57.0cm Aperture (H x W x D): 60.0-60.4 x 86.0-86.4cm x 56.0cm Rating: 3300 W	Overall (H x W x D): 47.5 x 89.6 x 57.2cm Aperture (H x W x D): 47.7-48.0 x 86.0-86.4cm x 56.0cm Rating: 3100 W
Barcode	4242003802335	4242003802311 WHILE STOCKS LAST HV541ANS0 4242003666555



Model	HN678G4S1	HS636GDS1
Product description	iQ700 Combi microwave oven with added steam	iQ700 Full steam oven
Heating methods	4D hot air, Hotair Eco, Top/bottom heat, Top/bottom heat Eco, Hot air grilling, Full width grill, Half width grill, Pizza setting, CoolStart function, Bottom heat, Intensive heat, Slow cook, Plate warming, Drying, Keep warm Additional heating methods with steam: Regeneration, fermentation VarioSpeed: heating methods combined with microwave settings 5 Microwave power settings (90 W, 180 W, 360 W, 600 W, 900 W) with Inverter	4D hot air, Hot air Eco, Top/bottom heat, Top/bottom heat Eco, Hot air grilling, Full width grill, Half width grill, Pizza setting, CoolStart function, Bottom heat, Slow cook, Plate warming, Keep warm Additional heating methods with steam: Steam 100%, Regeneration, fermentation, Defrost
Comfort and safety	Cavity net volume: 67 Litres Temperature range 30°C - 300°C 5,7"-TFT-color and graphics display with direct touch function Temperature proposal Actual temperature display Sabbath setting Added steam function Descaling programme Automatic boiling point detection Drying function Oven door with softMove Dish categories Multipoint temperature probe Baking sensor Electronic clock Rapid heating-up LED-Elongated light, Independent oven interior light button Water tank, 1 litre Location of the steam generator is outside of the cavity Integral cooling fan Stainless-steel fan Info button Maximum window temperature 30° C Door lock electrical Child lock Residual heat indicator	Cavity net volume: 71 Litres Temperature range 30°C - 250°C 3,7"-TFT-color and graphics display with direct touch function Temperature proposal Actual temperature display Sabbath setting Added steam function Descaling programme Automatic boiling point detection Drying function Oven door with softMove Dish categories Multipoint temperature probe Electronic clock Rapid heating-up LED light, Independent oven interior light button Water tank, 1 litre Location of the steam generator is outside of the cavity Integral cooling fan Stainless-steel fan Info button Bar handle Maximum window temperature 40° C Child lock Residual heat indicator
Design	Rotary Control Cavity inner surface: Enamel anthracite Bar handle Cavity with shelf support rails, 1 level telescopic shelf, pyrolytic proof	Rotary Control Cavity inner surface: Enamel anthracite Bar handle Cavity with shelf support rails
Cleaning	activeClean Pyrolytic proof trayholder and baking tray	Ecolyse features: back panel
Accessories	1 x Combination grid, 1 x Enamel baking tray, 1 x Universal pan	1 x Grid, 1 x Steam container, punched XL, 1 x Steam container, punched S, 1 x Steam container, unpunched, 1 x Enamel baking tray, 1 x Universal pan
Product specs	Overall (H x W x D): 59.5 x 59.5 x 54.8 cm Aperture (H x W x D): 58.5 - 59.5 x 56.0 - 56.8 x 55.0 cm Rating: 3650W	Overall (H x W x D): 59.5 x 59.5 x 54.8 cm Aperture (H x W x D): 58.5 - 59.5 x 56.0 - 56.8 x 55.0 cm Rating: 3650W
Barcode	4242003658789	4242003658314

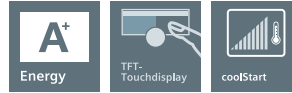

Model	HM656GBS1	HB636GBS1
Product description	iQ700 Oven with microwave	iQ700 Oven
Heating methods	4D hot air, Hot air Eco, Top/bottom heat, Top/bottom heat Eco, Hot air grilling, Full width grill, Half width grill, Pizza setting, CoolStart function, Bottom heat, Slow cook, Plate warming, Keep warm VarioSpeed: heating methods combined with microwave settings 5 Microwave power settings (90 W, 180 W, 360 W, 600 W, 900 W) with Inverter	4D hot air, Hot air Eco, Top/bottom heat, Top/bottom heat eco, Hot air grilling, Full width grill, Half width grill, Pizza setting, CoolStart function, Bottom heat, Slow cooking, Plate warming, Keep Warm
Comfort and safety	Cavity net volume: 67 Litres Temperature range 30°C - 300°C 3,7"-TFT-color and graphics display with direct touch function Temperature proposal Actual temperature display Sabbath setting Oven door with softMove Dish categories electronic clock Rapid heating-up LED light, Independent oven interior light button Integral cooling fan Stainless-steel fan Info button Maximum window temperature 40°C Child lock Residual heat indicator	Cavity net volume: 71 Litres Temperature range 30°C - 300°C 3,7"-color and text display with touch-control buttons Temperature proposal Actual temperature display Sabbath setting Oven door with softMove Dish categories Electronic clock Rapid heating-up Halogen interior lighting, Independent oven interior light button Stainless-steel fan Info button Maximum window temperature 40°C Child lock Residual heat indicator
Design	Rotary Control Cavity inner surface: Enamel anthracite Bar handle Cavity with shelf support rails	Rotary Control Cavity inner surface: Enamel anthracite Bar handle Cavity with shelf support rails (telescopic rails available as accessory)
Cleaning	Ecolyse features: ceiling, back panel, side liners Ecolyse programme/EcoClean Plus	Ecolyse features: back panel Full glass inner door
Accessories	1 x Combination grid, 1 x Enamel baking tray, 1 x Universal pan	1 x Enamel baking tray, 1 x Combination grid, 1 x Universal pan
Product specs	Overall (H x W x D): 59.5 x 59.5 x 54.8 cm Aperture (H x W x D): 58.5 - 59.5 x 56.0 - 56.8 x 55.0 cm Rating: 3650W	Overall (H x W x D): 59.5 x 59.5 x 54.8 cm Aperture (H x W x D): 58.5 - 59.5 x 56.0 - 56.8 x 55.0 cm Rating: 3650W
Barcode	4242003658758	4242003672402



Model	HB633GBS1	HB557G4S0
Product description	iQ700 Oven	iQ500 Oven
Heating methods	4D hot air, Hotair Eco, Top/bottom heat, Top/bottom heat Eco, Hot air grilling, Full width grill, Half width grill, Pizza setting, CoolStart function, Bottom heat	3D hotAir plus, Top/bottom heat, Hot Air grilling, Full width grill, Pizza setting, Bottom heat, hotAir gentle
Comfort and safety	Cavity net volume: 71 Litres Temperature range 30°C - 300°C 2.8" TFT-color and text display with touch-control buttons Temperature proposal Actual temperature display Sabbath setting Oven door with softMove Electronic clock Rapid heating-up Halogen interior lighting, Independent oven interior light button Stainless-steel fan Info button Maximum window temperature 40° C Child lock Residual heat indicator	Cavity net volume: 71 Litres Temperature range 50 °C - 275 °C LCD Display (white) Oven door with softClose Electronic clock cookControl10 Rapid heating-up Halogen interior lighting Maximum window temperature 40°C Child lock
Design	Rotary Control Cavity inner surface: Enamel anthracite Bar handle Cavity with shelf support rails (telescopic rails available as accessory)	Rotary Control Cavity inner surface: Enamel grey Bar handle Telescope pull-out for 3 levels, including one varioClip rail
Cleaning	Full glass inner door	Full glass inner door ecoClean Plus: coating of side liners, ceiling, back panel ecoClean program
Accessories	1 x Combination grid 1 x Universal pan	1 x Enamel baking tray 1 x Combination grid 1 x Universal pan
Product specs	Overall (H x W x D): 59.5 x 59.5 x 54.8 cm Aperture (H x W x D): 56.0-56.8 x 58.5-59.5 x 55.0 cm Rating: 3650W	Overall (H x W x D): 59.5 cm x 59.4 cm x 54.8 cm Aperture (H x W x D): 58.5-59.5 cm x 56.5-56.8 cm x 55.0 cm Rating: 3600W
Barcode	4242003672365	4242003815335



Always pleases the eye

The same coordinated design, throughout the iQ700 range.

Different models come with different functionalities, however with the iQ700 range of compact45 appliances, the design and style is coordinated to offer more flexibility when designing your kitchen.

Every appliance upgraded

No matter which model you choose from the iQ700 range, they all feature a TFT display to show programme information. The smallest TFT Display is operated by touch-control buttons either side of the screen and can be read from any angle. No more confusing icons, the screen displays text to make it even easier to use your appliance.

More options in one

As well as multifunction ovens with microwave, the iQ700 range can also be used as microwaves on their own. Power levels ranging from 90W to 1000W mean the microwave function can be used for gently defrosting food, reheating, cooking and quickly heating up drinks.

The iQ700 compact45 range:
the perfect solution for complete
coordination in your kitchen.



Model	CM656GBS1	BE634RGS1 (RIGHT HINGED) BE634LGS1 (LEFT HINGED)	BE555LMS0
Product description	iQ700 Compact oven with microwave	iQ700 Built-in microwave with grill	iQ500 Built-in microwave with grill
Heating methods	4D hot air, Hot air Eco, Top/bottom heat, Top/bottom heat Eco, Hot air grilling, Full width grill, Half width grill, Pizza setting, CoolStart function, Bottom heat, Slow cooking, Plate warming, Keep warm VarioSpeed: heating methods combined with microwave settings 5 Microwave power settings (90 W, 180 W, 360 W, 600 W, 1000 W) with Inverter	5 Microwave power settings (90 W, 180 W, 360 W, 600 W, 900 W) with Inverter Variable quartz Grill Combination of Grill and Microwave power levels 360/180/90 W	5 Microwave power settings: (90 W, 180 W, 360 W, 600 W, 900 W) Grill power 1200W Combination of Grill and Microwave power levels 360/180/90 W
Comfort and safety	Cavity net volume: 45 Litres Temperature range 30°C - 300°C 3,7"-TFT-color and graphics display with direct touch function Temperature proposal Actual temperature display Sabbath setting Oven door with softMove Dish categories Electronic clock Rapid heating-up LED Light, Independent oven interior light button Stainless-steel fan Info button Maximum window temperature 30° C Child lock Residual heat indicator	Cavity net volume: 21 Litres 2,8"-TFT-color and text display with touch-control buttons cookControl 10 Side opening door LED light Info button Open door button Start-/Stop button	Cavity net volume: 25 Litres Electronic clock Touch control 8 Automatic Programmes: 4 defrost 3 cooking programmes in microwave 1 for combination function 1 memory function LED light 31.5 cm Glass Door left hinged
Design	Rotary Control Cavity inner surface: Enamel anthracite Bar handle Cavity with shelf support rails	Cavity inner surface: Stainless steel	Cavity inner surface: Stainless steel
Cleaning	Ecolyse features: ceiling, side liners, back panel Ecolyse programme/EcoClean Plus		
Accessories	1 x Combination grid, 1 x Universal pan	1 x Glass pan 1 x Grid	1 x Grid 1 x Turntable
Product specs	Overall (H x W x D): 45.5 x 59.5 x 54.8 cm Aperture (H x W x D): 45.0 – 45.5 x 56.0 – 56.8 x 55.0 cm Rating: 3650W	Overall (H x W x D): 38.2 x 59.4 x 31.8 cm Aperture (H x W x D): 36.2-36.5 x 56.0 x 30.0 cm Rating: 1990W	Overall (H x W x D): 38.2 x 59.4 x 38.8 cm Aperture (H x W x D): 56.0 – 56.8 x 38.0 – 38.2 – 55.5 cm Rating: 1450W
Barcode	4242003658369	BE634RGS1 (Right Hinged) 4242003676387 BE634LGS1 (Left Hinged) 4242003676363	4242003805695



The healthy option

When compromise is not an option, hot air steam is the solution.

The iQ700 compact45 steam oven offers even more possibilities to prepare perfectly tasty dishes with ease. Use fullSteam to cook vegetables, fish or potatoes, without losing taste, colour or vitamins. And since no oil is needed, you can cook in the healthiest possible way. All compact45 appliances are now coordinated in design, to match with the iQ700 single ovens.



Convenient access to the water tank.

The many benefits of steam

As well as healthy cooking, steam is ideal for reheating and defrosting food. As the process gently adds moisture, you can reheat dishes when in a hurry, without losing taste, or spontaneously defrost food quickly.

More cooking possibilities

Our steam ovens are multi-functional meaning you can cook as a conventional oven or in combination with the pulseSteam function. Whether it's a quick and healthy meal after work or an impressive weekend fish dish, a Siemens compact45 steam oven lets you choose how you want to cook your food.

The easiest way to cook with steam

Cooking with steam is simple with an iQ700 compact45 steam oven. Open the fascia with the touch of a finger and the front panel automatically lifts to reveal the 1 litre capacity water tank. As the water tank is outside of the oven cavity, it's now possible to refill the tank while cooking, without losing any steam or disturbing your cooking.



Model	CS658GRS2	BI630DNS1	BI630CNS1
Product description	iQ700 Compact steam oven	iQ700 Warmer drawer (29 cm)	iQ700 Warmer drawer (14 cm)
Cooking methods	4D hot air, Hot air Eco, Top/bottom heat, Top/bottom heat Eco, Hot air grilling, Full width grill, Half width grill, Pizza setting, CoolStart function, Bottom heat, Intensive heat, Slow cooking, Plate warming, Drying, Keep warm Additional heating methods with steam: Steam 100%, Regeneration, fermentation, Defrost	Heating plate made of toughened glass Temperature control in 4 levels: ca. 40°C - 80°C (glass surface temperature)	Heating plate made of toughened glass Temperature control in 4 levels: ca. 40°C - 80°C (glass surface temperature)
Comfort and safety	Cavity net volume: 47 Litres Temperature range 30°C - 250°C 5,7"-TFT-color and graphics display with direct touch function Temperature proposal Actual temperature display Sabbath setting Added steam function Descaling programme Automatic boiling point detection Drying function Oven door with softClose, soft opening Dish categories Baking sensor Multipoint temperature probe Electronic clock Rapid heating-up LED light, Independent oven interior light button Water tank, 1 litre Location of the steam generator is outside of the cavity Stainless-steel fan, Info button Maximum window temperature 40° C Child lock, Residual heat indicator	Cavity net volume: 52 Litres Loading up to 25 kg Max. loading espresso cups: 192 PC Max. loading plates: 40PC 5 Functions: dough proving, thawing of delicate foods, keeping drinks and food warm, pre-warming of crockery, gentle cooking Telescopic pull-out drawer Cool door Push & Pull	Cavity net volume: 20 Litres Loading up to 25 kg Max. loading espresso cups: 64 PC Max. loading plates: 12PC 5 Functions: dough proving, thawing of delicate foods, keeping drinks and food warm, pre-warming of crockery, gentle cooking Telescopic pull-out drawer Cool door Push & Pull
Design	Rotary Control Cavity inner surface: Enamel anthracite Bar handle Cavity with shelf support rails, 1 level telescopic shelf, full extension, with Stop function		
Cleaning	Ecolyse features: side liners, back panel, ceiling Ecolyse program		
Accessories	1 x Grid, 1 x Steam container, punched XL, 1 x Steam container, punched S, 1 x Steam container, unpunched S, 1 x Universal pan		
Product specs	Overall (H x W x D): 45.5 x 59.5 x 54.8 cm Aperture (H x W x D): 45.0 – 45.5 x 56.0 – 56.8 x 55.0 cm Rating: 3300W	Overall (H x W x D): 29.0 x 59.5 x 54.8 cm Aperture (H x W x D): 29.0 x 56.0 - 56.8 x 55.0 cm Rating: 810W	Overall (H x W x D): 14.0 x 59.5 x 54.8 cm Aperture (H x W x D): 14.0 x 56.0 - 56.8 x 55.0 cm Rating: 810W
Barcode	4242003839300	4242003676615	4242003676561



Coffee indulgence

What takes a barista years to learn, you can do at the touch of a button.

The finishing touch for your kitchen or dining area, a Siemens coffee centre is the ultimate appliance for coffee lovers and those who like to entertain. Enjoy a better selection of coffee drinks with the touch of a finger, all made to the optimum temperature to release the best taste and aroma using the intelligent sensoFlow heater.



Perfect results and at the size you want.

AutoMilk Clean

Now you can clean your coffee maker as easily as you prepare your morning pick-me-up. Each time you make a coffee drink with milk, the milk system is automatically rinsed out with a blast of steam. The coffee machine takes total charge of the milk system's daily maintenance, so that you can concentrate on enjoying your cappuccino or latte macchiato instead of cleaning.

individualCup volume size

Precisely the amount of coffee you want – exactly how you want it. The cup volume can be set to perfection, so that your favourite coffee fits in your favourite cup perfectly.

OnceTouch DoubleCup

You can make two of the same coffees simultaneously, even those that use milk.

sensoFlow for coffee perfection

Different coffees require the espresso shot to be heated at different temperatures to achieve the perfect result. sensoFlow does this automatically, providing you with a delicious beverage again and again. For an added boost aromaDoubleShot gives you that extra boost when you need it most. Because the second shot uses a new set of beans, there's no compromise on the flavour.



Model	CT636LES1
Product description	iQ700 Integrated fully automatic espresso/coffee machine
Comfort and safety	<p>Flavour SensoFlow System: The innovative heating system guarantees a constant brewing temperature AromaPro Concept: Ideal contact pressure for optimal aroma extraction One-touch preparation: Ristretto, Espresso, Espresso Macchiato, Coffee, Cappuccino, Latte Macchiato, Caffè Latte at the touch of a button AromaDouble Shot: Extra-strong coffee with less bitterness thanks to two grinding and brewing processes Beverage temperature adjustable individually: coffee 3 levels, hot water 4 levels</p> <p>Convenience MyCoffee: Save 8 beverages with individual names and adjustable mixing ratio of milk and espresso IndividualCup Volume: Cup sizes adjustable individually Coffee outlet and milk frother height-adjustable: Up to 15 cm high OneTouch DoubleCup: Prepare two cups simultaneously for all coffee and milk specialities Removable Water tank (2.4 Litres volume)</p> <p>Performance SilentCeram Drive: Quiet premium grinder made from non-wearing ceramic CoffeeSensor Pro: The grinding unit automatically adjusts to bean variety One-touch coffee milk specialities with especially fine-pored milk froth thanks to an innovative milk frother In addition to beverages also available separately: milk foam, warm milk, hot water Reduced heat-up time: Fastest first cup Water pump with 19 bar pressure Separate chute for ground coffee</p> <p>Cleaning Removable brewing unit: Easy and hygienic cleaning under running water AutoMilk Clean: Fully-automatic steam cleaning of the milk system after every beverage Milk frother removable and dishwasher-proof SinglePortion Cleaning: Complete emptying of all pipes after each brewing process Automatic rinsing program when switching off and on Drip tray and coffee grounds container removable and dishwasher-proof Calc'nClean: Automatic cleaning and descaling programme</p> <p>Miscellaneous Bean container with aroma protection lid (500 g volume) Coffee outlet and keys are illuminated Grinding fineness adjustable (multi-level) Display language selectable Child safety lock: Unintended brewing process not possible</p>
Product specs	Overall (H x W x D): 45.5 x 59.4 x 38.5 cm Aperture (H x W x D): 45.0 x 56.8 x 40.0 cm Rating: 1700 W
Barcode	4242003645437



Induction and ceramic hobs

Easy to clean, easy to cook with.

Speed Energy-efficiency Style

Our traditional induction hob range feature automatic pan recognition ensuring that only the pan in contact with the surface heats up. Induction cooking is quicker than gas and more energy efficient, allowing you to enjoy speedy meals whilst being kinder to the environment.

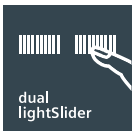

Dual lightSlider*

The perfect symbiosis of precision, convenience and design. The optimal way to control your cooktop. Innovative lightSlider technology combines innovative light design, with simple precise heat regulation.

Designed with sleek controls that are simple to use, and state-of-the-art technology that gives you a precise control over your hob. When activated, the power level is displayed for each zone, allowing you to monitor their status at a glance.



flexInduction*

One cooking zone, a thousand possibilities
Pots and pans are as different as the dishes you cook with them. With flexinduction you can flexibly adjust your cooktop to fit. The cooking area can be tailored to your needs, enabling you to use a small area or you can choose to link the zones together to form one large zone. Only if cookware is detected will the individual inductors work

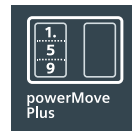

PowerMove Plus*

This function activates the entire flexible cooking zone, which is divided into three cooking areas and which has preset heat settings. This means that an item of cookware can be moved during the cooking process to another cooking area with another heat setting.

Automatic pan recognition*

Energy-efficiency is at the heart of Siemens products, and is at the heart of automatic pan recognition. Only the area of the hob in contact with the pan receives energy, meaning energy isn't wasted by heating the entire unit. Not only will this lower your carbon footprint, but it will also reduce your utility bills.

PanBoost*

Shorter heat-up times for pans (and pots with non-stick coating) This function only runs 30seconds (compared to 10min for powerBoost).
After 30 seconds it automatically switches to level 9.

*Selected models only



Model	EX975KXW1E	EX975LVC1E
Product description	iQ700 90cm flex induction ceramic hob, full touch TFT display	iQ700 90cm flex induction ceramic hob
Comfort and safety	<ul style="list-style-type: none"> 5 induction cooking zones 3 flex zones flexMotion powerMove plus fryingSensor plus with 5 temperature settings cookingSensor Plus (sensor sold separately) Meal assistant Automatic pan recognition sensor PowerBoost function for all zones panBoost Keep warm function for all cooking zones 17 power levels Timer with switch-off function for all zones Count-up timer powerManagement function reStart function Wipe protection function Digital 2-step residual heat indicator for each zone Wipe protection function Safety switch-off Childproof lock 	<ul style="list-style-type: none"> 5 Induction cooking zones 1 Triple Zone 2 Flex induction zones Dual lightSlider touch control powerMove Plus Automatic pan recognition sensor fryingSensor Plus with 5 temperature settings PowerBoost function for all zones panBoost powerManagement function reStart Function quickStart Function Energy efficiency display 17 power levels Switch off timer for every cooking zone Count-up timer symControl, symmetrical position of displays Reidual heat indicator for each zone Wipe protection function Safety switch-off Childproof lock
Design	Glass ceramic Min. Worktop thickness: 30mm	Glass ceramic Can be combined with all hobs in comfort design Min worktop thickness 30mm
Optional accessories	<ul style="list-style-type: none"> HZ39050 Cooking Sensor HZ390090 Wok Set HZ390011 Induction Roaster for flex induction HZ390012 Steaming rack for Roaster HZ390512 Teppanyaki for flex induction HZ390522 Griddle plate for induction HZ390220 pan diameter 19cm HZ390042 set of 3 pots and 1 pan for induction hobs 	<ul style="list-style-type: none"> HZ390011 Induction Roaster for flex induction HZ390012 Steaming rack for Roaster HZ390512 Teppanyaki for flex induction HZ390522 Griddle plate for induction HZ390250 Frying Sensor Pan Ø 21cm HZ390042 set of 3 pots and 1 pan for induction hobs
Product specs	Overall (H x W x D): 5.1 x 91.2 x 52.0 cm Aperture (H x W x D): 5.1 x 88.0 x 49.0-50.0 cm Rating: 11100 W	Overall: (H x W x D): 5.1 x 91.2 x 52.0cm Aperture: (H x W x D): 5.1 x 88.0 x 49.0-50.2cm Rating: 11100W
Barcode	4242003765685	4242003705599

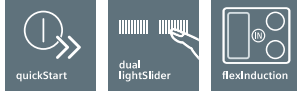
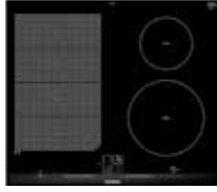

Model	EX675LEC1E	ET975LMP1D
Product description	iQ700 60cm induction ceramic hob faceted design	iQ300 90cm ceramic hob, electric
Comfort and safety	<ul style="list-style-type: none"> 4 Induction cooking zones 1 flexInduction zone Dual lightSlider touch control powerMove Plus Automatic pan recognition sensor fryingSensor Plus with 5 temperature settings Boost function for all zones panBoost powerManagement Function reStart Function quickStart Function Energy efficiency display 17 power levels Switch off timer for every cooking zone timer Count-up timer symControl, symmetrical position of displays Residual heat indicator for each zone Safety switch-off Childproof lock 	<ul style="list-style-type: none"> 5 HighSpeed cooking zones: 1 triple zone, 1 dual zone, 1 combiZone Dual lightSlider touch control 17 power levels PowerBoost function Digital display Switch off timer for every cooking zone Count-up timer Keep warm function for all cooking zones reStart Function Individual tunable energy consumption display Wipe protection function Digital 2-step Residual heat indicator for each zone Childproof lock Safety switch-off
Design	<ul style="list-style-type: none"> Facetted design (can be combined with all hobs in comfort design) Min. worktop thickness: 30 mm 	<ul style="list-style-type: none"> Glass ceramic Min worktop thickness 20mm
Optional accessories	<ul style="list-style-type: none"> HZ390011 Induction Roaster for flex induction HZ390512 Teppanyaki for flex induction HZ390522 Griddle plate for induction HZ394301 Joining strip HZ390250 Frying Sensor Pan Ø 21cm HZ390042 set of 3 pots and 1 pan for induction hobs 	<ul style="list-style-type: none"> HZ394301 joining strip HZ390011 Induction Roaster for flex induction HZ390512 Teppanyaki for flex induction HZ390522 Griddle plate for induction
Product specs	<ul style="list-style-type: none"> Overall (H x W x D): 5.1 x 60.2 x 52.0 cm Aperture (H x W x D): 5.1 x 56.0 x 49.0-50.0 cm Rating: 7400W 	<ul style="list-style-type: none"> Overall: (H x W x D): 4.5 x 91.2 x 52.0cm Aperture: (H x W x D): 4.5 x 88.0 x 50.0cm Rating: 10900W
Barcode	4242003716854	4242003749562



Model	ET675FNP1E	ET611HE17E
Product description	iQ300 60cm ceramic hob, electric	iQ100 60 cm ceramic hob, electric
Comfort and safety	4 HighSpeed cooking zones: 1 dual zone, 1 with extendable oval zone Dual touchSlider mono 17 power levels PowerBoost function Digital display Switch off timer for every cooking zone Count-up timer reStart Function Individual tunable energy consumption display Wipe protection function Digital 2-step Residual heat indicator for each zone Childproof lock Safety switch-off	4 HighSpeed cooking zones touchControl 17 power levels Electronic display symControl, symmetrical position of displays Childproof lock Safety switch-off reStart Function Power on indicator light Main switch
Design	Glass ceramic Min worktop thickness 20mm	Frameless design HighSpeed ceramic glass
Optional accessories	HZ394301 joining strip	
Product specs	Overall: (H x W x D): 4.5 x 60.2 x 52.0cm Aperture: (H x W x D): 4.5 x 56.0 x 49.0-50.0cm Rating: 8300W	Overall (H x W x D): 4.5 x 59.2 x 52.2cm Aperture: (H x W x D): 4.5 x 56.0 x 49.0-50.0cm Rating: 6600W
Barcode	4242003762851	4242003640388

Mix and match

The modular domino hobs can be mixed and matched with each other and selected hobs in the Siemens range.



Model	ET475FYB1E	EX375FXB1E	EH375FBB1E
Product description	iQ500 40cm teppan yaki	iQ700 30cm flexinduction ceramic hob faceted design	iQ700 30cm induction ceramic hob faceted design
Comfort and safety	Big stainless steel roast area touchSlider Frying area can be heated complete or halfway Electronic display Thermostat can be set between 160-240°C in steps of 10°C Special level for keeping warm (70°C) Special level for cleaning (40°C) Timer Count-up timer reStart Function Display of the heat up phase 2-fold residual heat indication Wipe protection function Safety switch-off Childproof lock	Flex zone 2 induction cooking zones Automatic pan recognition sensor powerMove Plus reStart Function quickStart Function Boost function for all zones Switch off timer for every cooking zone Count-up timer Wipe protection function Safety switch-off Childproof lock	2 induction cooking zones Automatic pan recognition sensor reStart Function quickStart Function Boost function for all zones Energy efficiency display Switch off timer for every cooking zone powerManagement Function Digital 2-step Residual heat indicator Wipe protection function Safety switch-off Childproof lock
Design	Faceted design Removable black glass lid Min. worktop thickness: 30 mm	Faceted design Min. worktop thickness: 30 mm	Faceted design Min. worktop thickness: 30 mm
Optional accessories	HZ394301 Joining strip	HZ390011 Induction Roaster for flex induction HZ390512 Teppanyaki for flex induction HZ390522 Griddle Plate for flex induction HZ394301 Joining strip	HZ394301 Joining strip
Product specs	Overall (H x W x D): 9.0 x 39.2 x 52.0 cm Aperture (H x W x D): 9.0 x 36.2 x 49.0-50.0 cm Rating: 1900W	Overall (H x W x D): 5.1 x 30.2 x 52.0 cm Aperture (H x W x D): 5.1 x 27.0 x 49.0-50.0 cm Rating: 3700W	Overall (H x W x D): 5.3 x 30.2 x 52.0 cm Aperture (H x W x D): 5.3 x 27.0 x 49.0-50.0 cm Rating: 3700W
Barcode	4242003689127	4242003697405	4242003691731



Model	ET375FFP1E	ET375FUB1E (WHILE STOCKS LAST)	ET375FAB1E (WHILE STOCKS LAST)
Product description	iQ300 30cm ceramic hob, faceted design	iQ500 30cm electric lava grill, faceted design	iQ500 30 cm deep fat fryer
Comfort and safety	2 HighSpeed cooking zones, including 1 dual zone touchSlider 17 power levels PowerBoost function Electronic display Timer with switch-off function for all zones Count-up timer reStart function Wipe protection function Digital 2-step residual heat indicator for each zone Childproof lock Safety switch-off	Stainless steel grill to be used with water or lava stones touchSlider 17 power levels Electronic display Timer and Count-up timer Display of the heat up phase and Residual heat indicator Wipe protection function Safety switch-off and Childproof lock	touchSlider Huge frying basin (ca. 3-4 l) Basket with hanger to turn down Oil drainage outlet Electronic display Thermostat can be set between 100-190° C Grease melting point (100° C) cold oil zone Count-up timer and Timer Wipe protection function reStart Function Power on indicator light Display of the heat up phase Childproof lock&Safety switch-off
Design	To be combined with all hobs in comfort design Min. Worktop thickness: 20mm	Faceted design Removable black glass lid Min. worktop thickness: 30 mm	Removable black glass lid
Optional accessories	HZ394301 Joining strip	HZ394301 Joining strip	HZ394301 Joining strip
Product specs	Overall (H x W x D): 3.8 x 30.2 x 52.0 cm Aperture (H x W x D): 3.8 x 27.0 x 49.0-50.0 Rating: 3500 W	Overall (H x W x D): 23.6 x 30.2 x 52.0 cm Aperture (H x W x D): 23.6 x 27.0 x 49.0-50.0 cm Rating: 2400W	Overall (H x W x D): 36.7 x 30.2 x 52.0cm Aperture: (H x W X D): 36.7 x 27.0 x 49.0-50.0cm Rating: 2500W
Barcode	4242003755075	4242003687635	4242003689073



Model	ER3A6AD70	ER3A6BD70
Product description	iQ700 30cm gas hob with wok burner, stepFlame Technology	iQ700 30cm 2 burner gas hob, stepFlame Technology
Comfort and safety	1 Dual wok Burner 6.0kW stepFlame Technology Digital display to indicate power levels Electronic ignition via front control Pan supports dishwasher proof Residual heat indicator Flame failure safety device	1 Rapid burner 2.8kW 1 Standard burner 1.9kW stepFlame Technology Digital display to indicate power levels Electronic ignition via front controls Pan supports dishwasher proof Residual heat indicator Flame failure safety device
Design	Ceramic top sheet Cast iron continuous pan supports (dishwasher safe) Design burner - special flat design	Ceramic top sheet Cast iron continuous pan supports (dishwasher safe) Design burner - special flat design
Optional accessories	HZ394301 Joining strip	HZ394301 Joining strip
Product specs	Overall: (H x W x D): 4.5 x 30.2 x 52.0cm Aperture: (H x W x D): 4.5 x 27.0 x 49.0-50.0cm	Overall: (H x W x D): 4.5 x 30.2 x 52.0cm Aperture: (H x W x D): 4.5 x 27.0 x 49.0-50.0cm
Barcode	4242003742631	4242003742693



Gas hobs

High performance, high speed.

Precise flame control.

Gas hobs with stepFlame technology combine the predefined cooking settings of an electric hob with gas.

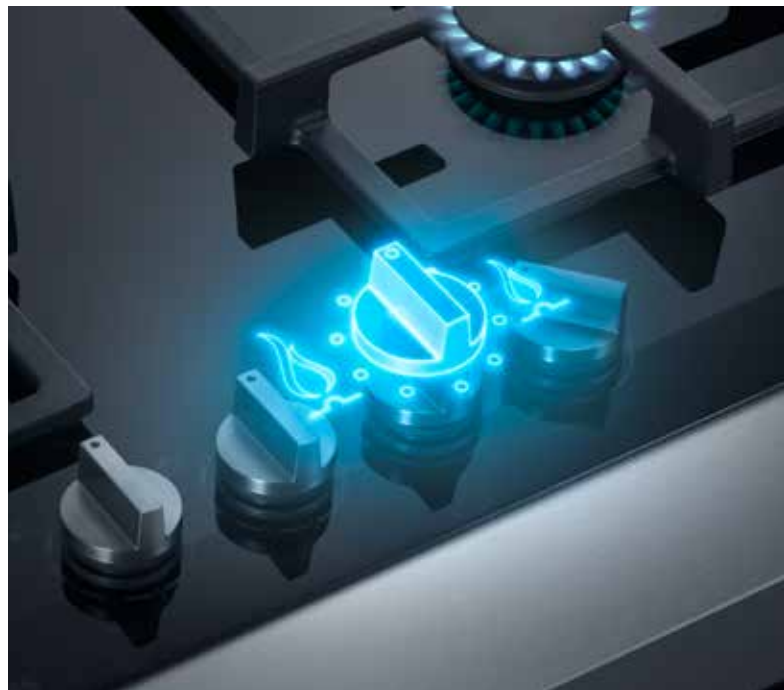

Professional and amateur cooks alike appreciate the advantages of cooking over an open flame, and with Siemens they get the ideal way to do it – modern gas hobs in high-end styling. With Siemens gas hobs, pots and pans heat up quickly and your food is ready on the dot. All Siemens gas hobs meet the highest safety standards and have modern burners, whose stepless adjustment let you get the perfect heat distribution for your cookware.

Total convenience guaranteed

Swift, fluid motions and ease of use are the focal points of control dial ignition. Ignite the flame whilst setting its intensity by simply turning and pushing the individual hob control with one hand, whilst preparing food with the other. Total convenience guaranteed.

High-performance. High-speed

Experience the wok burner The only way to cook a stir fry – enjoy precision cooking with the dual controlled wok burner. The inner and outer flame can be controlled independently, with the power burner allowing for extremely fast cooking.

Best of both worlds

When your heart is still ruled by the traditional method of cooking with gas but you would like to have the option of being more flexible with your cooking, you can add the more energy efficient flexInduction domino hob or really stand out of the crowd with the Teppan yaki cooktop enjoying the best of both worlds.

Ideal for the perfect jus

Ideal for simmering the perfect jus, the simmer burner cap fits on the smallest burner and diffuses the minimum power heat over a wider surface area, avoiding hot spots, perfect for simmering.

Safety first

When you have a window open nearby whilst cooking, the flame can sometimes be extinguished. All Siemens gas hobs feature a flame failure safety device, which cuts-off the supply of gas to the individual burner should the flame accidentally go out.

StepFlame*

Perfect cooking results with nine adjustable and reliable power levels. There is no need to check the height of the flame. Perfect cooking results each and every time. Innovative and patented valve technology regulates the gas output precisely and noticeably from levels 1 to 9.

*Selected models only



Model	ER9A6SD70	ER6A6PD70
Product description	iQ700 90cm gas hob with wok burner, stepFlame Technology	iQ700 60cm gas hob, stepFlame Technology
Comfort and safety	<ul style="list-style-type: none"> 1 Wok burner 6.0kW 1 Rapid burner 2.8kW 2 Standard burner 1.9kW 1 Economy burner 1.1kW stepFlame Technology Digital display to indicate power levels Electronic ignition via front controls Residual heat indicator Flame failure safety device	<ul style="list-style-type: none"> 1 Rapid burner 2.8kW 2 Standard burner 1.9kW 1 Economy burner 1.1kW stepFlame Technology Digital display to indicate power levels Electronic ignition via front controls Residual heat indicator Flame failure safety device
Design	Ceramic top sheet Cast iron continuous pan supports (dishwasher safe) Design burner - special flat design	Ceramic top sheet Cast iron continuous pan supports (dishwasher safe) Design burner - special flat design
Product specs	Overall: (H x W x D): 4.5 x 91.2 x 52.0cm Aperture: (H x W x D): 4.5 x 85.0-85.2 x 49.0-50.2cm	Overall: (H x W x D): 4.5 x 60.2 x 52.0cm Aperture: (H x W x D): 4.5 x 56.0-56.2 x 49.0-50.2cm
Barcode	4242003742846	4242003742754



Model	EC9A5RB90	EC6A5HC90
Product description	iQ500 90cm gas hob with wok burner, stepFlame Technology	iQ500 60cm gas hob with Wok Burner, stepFlame Technology
Comfort and safety	<ul style="list-style-type: none"> 1 Wok burner 5.0kW 1 Rapid burner 3.0kW 2 Standard burner 1.75kW 1 Economy burner 1.0kW stepFlame Technology Electronic ignition via front controls Flame failure safety device	<ul style="list-style-type: none"> 1 Wok burner 3.3kW 2 Standard burner 1.75kW 1 Economy burner 1.0kW stepFlame Technology Electronic ignition via front controls Flame failure safety device
Design	Stainless Steel Cast iron continuous pan supports Design burner - special flat design	Stainless Steel Cast iron continuous pan supports Design burner - special flat design
Product specs	Overall: (H x W x D): 4.5 x 9.15 x 52.0cm Aperture: (H x W x D): 4.5 x 85.0-85.2 x 49.0-50.2cm	Overall: (H x W x D): 4.5 x 58.2 x 52.0cm Aperture: (H x W x D): 4.5 x 56.0-56.2 x 48.0-49.2cm
Barcode	4242003742204	4242003742006



Extractors

Outstanding performance, intelligently designed.

With open plan living becoming more popular, a quiet, efficient and powerful extractor is necessary.



Enjoy a fresher kitchen

Ducted or recirculated air – whatever is right for your kitchen*

With the cooker hoods of the air extraction type, the kitchen air extracted by the fan is ducted to a vent through an outside wall (telescopic wall outlet) or into an air shaft. In contrast to the exhaust-air principle, which exchanges the air in the kitchen, the recirculating system scrubs the cooking fumes by passing them through grease filters and activated charcoal filters. The clean air is then returned to the kitchen.

Rim ventilation*

The rim filter is Siemens' patented stylish filter with a large stainless steel front. The innovative and easy-to-clean rim ventilation feature absorbs over 90% of grease from cooking steam.

BLDC - technology*

A BLDC (brushless direct-current) motor runs quietly and faultlessly at particularly high power. Its brushless drive system generates very little friction, saving a considerable amount of energy while meeting the specific requirements of household appliances.

cleanAir*

With cleanAir, Siemens offers an innovative recirculating module. Thanks to the large, slatted surface of the special active carbon filter, the cleanAir recirculating module can neutralise up to 95% of odours, putting it on par with a ducted system. This module is also extremely quiet.

*Selected models only



Model	LD97AA670B	LF959RB51	LF21BA552
Product description	iQ700 90 cm downdraft extractor exhaust or recirculation operation	iQ700 90 cm ceiling extractor exhaust or recirculation operation	iQ700 120 cm island extractor exhaust or recirculation operation
Comfort and safety	<p>Downdraft for installation on worktops</p> <p>Extension height: 40.6cm</p> <p>Electronic control via touch controls</p> <p>3 Speed settings plus Intensive setting</p> <p>Intensive setting with 5 or 10 minute reset facility</p> <p>Automatic 15 min. run on facility</p> <p>Twin Channel high performance motor</p> <p>Rim Ventilation</p> <p>Metal grease filter, dishwasher safe</p>	<p>Ceiling mounted extractor</p> <p>Electronic controls/radio remote control</p> <p>3 Speed settings plus Intensive setting with automatic reset facility</p> <p>Automatic 10 min. run on facility</p> <p>Rim Ventilation</p> <p>Saturation indicator for metal grease filter</p> <p>Filter cover Stainless steel</p> <p>Metal grease filter, dishwasher safe</p>	<p>Electronic control via touch controls from both sides</p> <p>3 Speed settings plus 2 intensive settings with automatic reset facility</p> <p>Automatic 10 min. run on facility</p> <p>Twin Channel high performance motor</p> <p>Efficient BLDC technology</p> <p>Rim Ventilation</p> <p>Saturation indicator for metal filter and charcoal filter</p> <p>Air quality sensor</p> <p>Metal grease filter, dishwasher safe</p>
Design	<p>softLight</p> <p>Light dimmer function</p> <p>Lighting: 1 x 10W LED lights</p>	<p>Lighting: 4 x 2.5W halogen lights</p>	<p>softLight</p> <p>Light dimmer function</p> <p>Lighting: 4 x 3W LED lights</p>
Min. clearance above cooking point		<p>Gas Appliances: 65.0cm (min.)</p> <p>Electrical Appliances: 55.0cm (min.)</p> <p>1.5m clearance above worktop, max.</p>	<p>Gas Appliances: 65.0cm</p> <p>Electrical Appliances: 55.0cm</p>
Special accessories	LZ53750 Active carbon filter	<p>LZ56700 CleanAir Recirculating Kit</p> <p>LZ56200 CleanAir Active Carbon Filter</p>	<p>LZ57600 CleanAir Recirculating Kit</p> <p>LZ56200 CleanAir Active Carbon Filter</p> <p>(Chimney extensions available on request)</p>
Product specs	<p>For technical dimension please refer to page: 55</p> <p>Rating: 285W</p> <p>Normal Extraction: 450m3/h</p> <p>Intensive Extraction: 710m3/h</p> <p>Noise Level, max. normal use: 61dB</p>	<p>For technical dimension please refer to page: 56</p> <p>Rating: 279 W</p> <p>Normal extraction : 570m3/h</p> <p>Intensive extraction : 780 m3/h</p> <p>Noise Level, max. normal use: 64dB</p>	<p>For technical dimension please refer to page: 55</p> <p>Rating: 272W</p> <p>Normal Extraction: 570m3/h</p> <p>Intensive Extraction: 730m3/h</p> <p>Noise Level, max. normal use: 62dB</p>
Barcode	4242003628881	4242003688014	4242003650592



Model	LF98BC542	LC91KWP60 (WHILE STOCKS LAST)
Product description	iQ700 90 cm island extractor exhaust or recirculation operation	iQ700 90 cm inclined design, wall mounted extractor exhaust or recirculation operation
Comfort and safety	Electronic control via push buttons from both sides 3 Speed settings plus 2 intensive settings with automatic reset facility Automatic 10 min. run on facility Twin channel high performance motor Efficient BLDC technology Saturation indicator for metal filter and charcoal filter Metal grease filter, dishwasher safe Stainless steel filter covers dishwasher safe	Electronic control via touchControl 3 Speed settings plus 2 intensive settings PowerBoost position Automatic 10 min run on facility Efficient BLDC technology Twin channel high performance motor Rim Ventilation 2 Capture areas: front side and bottom side Saturation indicator for metal filter and charcoal filter Filter cover glass Metal grease filter, dishwasher safe
Design	softLight Light dimmer function Lighting: 4 x 3W LED lights	Black with glass canopy In recirculation operation chimless use is possible Easy wall mounting system softLight Light dimmer function Lighting: 2 x 3W LED
Min. clearance above cooking point	Gas Appliances: 65.0cm Electrical Appliances: 55.0cm	Gas Appliances from upper edge of pan support: 60.0cm Electric Appliances: 45.0cm
Special accessories	LZ53850 Recirculation Kit LZ53451 Active Carbon Filter LZ57600 CleanAir Recirculation Kit* LZ56200 CleanAir Active Carbon Filter* *Available on request	LZ10AKU00 Recirculation Kit LZ10AKT00 Recirculation Kit for chimless use LZ10AKA00 Active Carbon Filter LZ10AXC50 CleanAir Recirculation Kit* LZ56200 CleanAir Active Carbon Filter* *Available on request
Product specs	For technical dimension please refer to page: 55 Rating: 172W Normal Extraction: 470m ³ /h Intensive Extraction: 870m ³ /h Noise Level, max. normal use: 54dB	For technical dimension please refer to page: 56 Rating: 266W Normal Extraction: 530m ³ /h Intensive Extraction 950m ³ /h Noise level, max normal use: 56dB
Barcode	4242003650349	4242003761045



Model	LC97FQP60	LC95KA670	LC67KHM60
Product description	iQ500 90 cm flat design, wall mounted extractor exhaust or recirculation operation	iQ300 90 cm inclined design wall mounted extractor exhaust or recirculation operation	iQ300 60 cm inclined design, wall mounted extractor exhaust or recirculation operation
Comfort and safety	Electronic control via touchControl 3 Speed settings plus 2 intensive settings PowerBoost position Automatic 10min run on facility Efficient BLDC technology Twin channel high performance motor Rim Ventilation 2 Capture areas: front side and bottom side Saturation indicator for metal and charcoal filter Filter cover glass Metal grease filter, dishwasher safe	Electronic control via touchControl 3 Speed settings Twin channel high performance motor Rim Ventilation Metal grease filter, dishwasher safe	Electronic control via touchControl 3 Speed settings plus intensive setting Energy efficient capacitor motor Twin channel high performance motor Rim Ventilation 2 Capture areas: front side and bottom side Saturation indicator for metal filter and charcoal filter Filter cover glass Metal grease filter, dishwasher safe
Design	Black with glass canopy In recirculation operation chimless use is possible Easy wall mounting system softLight Light dimmer function Lighting: 2 x 1.5W LED	Black with glass canopy Lightning: 2 x 3W LED	Black with glass canopy In recirculation operation chimless use is possible Easy wall mounting system Lighting: 2 x 1.5W LED
Min. clearance above cooking point	Gas Appliances from upper edge of pan support: 60.0cm Electric Appliances: 45.0cm	Gas Appliances: 57.0 cm Electrical Appliances: 47.0cm	Gas Appliances from upper edge of pan support: 60.0cm Electric Appliances: 45.0cm
Special accessories	LZ10AFU00 Recirculation Kit LZ10AFT00 Recirculation Kit for chimless use LZ10AFA00 Active Carbon Filter LZ10AXC50 CleanAir Recirculation Kit LZ56200 CleanAir Active Carbon Filter	LA10LKA6 Active Carbon Filter	LZ10AKU00 Recirculation Kit LZ10AKT00 Recirculation Kit for chimless use LZ10AKA00 Active Carbon Filter LZ10AXC50 CleanAir Recirculation Kit* LZ56200 CleanAir Active Carbon Filter* *Available on request
Product specs	For technical dimension please refer to page: 55 Rating: 143W Normal Extraction: 420m ³ /h Intensive Extraction 730m ³ /h Noise level, max normal use: 57dB	For technical dimension please refer to page: 55 Rating: 216 W Normal Extraction: 580m ³ /h Noise level, max normal use: 70dB	For technical dimension please refer to page: 56 Rating: 263W Normal Extraction: 400m ³ /h Intensive Extraction 660m ³ /h Noise level, max normal use: 57dB
Barcode	4242003761175	4242003809556	4242003760918



Model	LC91BE542 (WHILE STOCKS LAST)	LC94BBC50	LC64BA522 (WHILE STOCKS LAST)
Product description	iQ500 90 cm wall mounted extractor exhaust or recirculation operation	iQ100 90cm wall mounted extractor exhaust or recirculation operation	iQ100 60 cm wall mounted extractor exhaust or recirculation operation
Comfort and safety	Electronic control via push buttons 3 Speed settings plus 2 intensive settings with automatic reset facility Automatic 10 min. run on facility Twin channel high performance motor Efficient BLDC technology Saturation indicator for metal filter and charcoal filter Metal grease filter, dishwasher safe	Push buttons for extractor speeds and light 3 Speed settings Twin channel high performance motor Metal grease filter, dishwasher safe	Rocker switches for extractor speeds and light 3 Speed settings Metal grease filter, dishwasher safe
Design	softLight Light dimmer function Lighting: 3 x 3W LED lights	Lightning: 2 x 1.5W LED	Lighting: 2 x 20W halogen lights
Min. clearance above cooking point	Gas Appliances: 65.0cm Electrical Appliances: 55.0cm	Gas Appliances: 65.0 cm Electrical Appliances: 55.0cm	Gas Appliances: 65.0cm Electrical Appliances: 55.0cm
Special accessories	LZ53450 Recirculation Kit LZ53451 Active Carbon Filter LZ57300 CleanAir Recirculating Kit LZ56200 CleanAir Active Carbon Filter (Chimney extension available on request)	Special accessories LZ10DXU00 Recirculation Kit LZ10DXA00 Active Carbon Filter LZ57000 CleanAir Recirculation Kit*	LZ53250 Recirculation Kit LZ53251 Active Carbon Filter LZ57000 CleanAir Recirculation Kit* LZ56200 CleanAir Active Carbon Filter* *Available on request (Chimney extensions available on request)
Product specs	For technical dimension please refer to page: 56 Rating: 320W Normal Extraction: 640m ³ /h Intensive Extraction: 1000m ³ /h Noise Level, max. normal use: 61dB	For technical dimension please refer to page: 55 Rating: 100 W Normal Extraction: 330m ³ /h Noise level, max normal use: 64dB	For technical dimension please refer to page: 56 Rating: 170W Normal Extraction: 460m ³ /h Noise Level, max. normal use: 62dB
Barcode	4242003652039	4242003811177	4242003649770



Model	LB75564 (WHILE STOCKS LAST)	LB53NAA50
Product description	iQ300 70 cm canopy extractor exhaust or recirculation operation	iQ 100 60cm canopy extractor Exhaust or recirculation operation
Comfort and safety	Metal filter with aluminium frame 2 powerful motors 3 settings plus 1 intensive setting	Push buttons for extractor speeds and light 3 speeds Single motor Metal grease filter, dishwasher safe
Design	Fully integrated Worktop lighting with halogen bulbs (2 x 20 W)	Fully integrated Lighting: 2 x 4 W LED
Min. clearance above cooking point	Gas Appliances: 65.0cm Electrical Appliances: 55.0cm	Gas Appliances: 65.0cm Electrical Appliances: 55.0cm
Special accessories	LZ73050 Recirculation Kit	LZ10INT00 Recirculating Kit LZ10INA00 Active Carbon Filter
Product specs	For technical dimension please refer to page: 55 Rating: 240W Normal Extraction: 400 m3/h Intensive Extraction: 650 m3/h Noise level: 59 dB/400 m3/h	For technical dimensions please refer to page: 55 Rating: 121W Max Extraction: 300m³/h Noise level: 61 dB/300m³/h
Barcode	4242003271865	4242003831700

Accessories for extractors

Model	Accessory	Description	Price Incl. VAT*	Price Excl. VAT*
LD97AA670B	LZ53750	Active Carbon Filter	R 851,30	R 979,00
LF959RB50/51	LZ56700	CleanAir Recirculation Kit	R 6 373,04	R 7 329,00
LF959RB50/51 / LF21BA552 / LF98BC542 / LF98BB542 / LC21BD552 / LC98GA542 / LC98KD672 / LC98KPP60 / LC97FQP60 / LC91KWP60 / LC67KHM60 / LC91BE542 / LC67BB532 / LC64BA522	LZ56200	CleanAir Active Carbon Filter	R 4 251,30	R 4 889,00
LF21BA552 / LF98BC542 / LF98BB542	LZ57600	CleanAir Recirculation Kit	R 4 677,39	R 5 379,00
LF98BC542 / LF98BB542	LZ53850	Recirculation Kit	R 851,30	R 979,00
LF98BC542 / LF98BB542 / LC21BD552 / LC91BE542	LZ53451	Active Carbon Filter	R 851,30	R 979,00
LC21BD552 / LC91BE542	LZ57300	CleanAir Recirculation Kit	R 4 251,30	R 4 889,00
LC21BD552 / LC91BE542	LZ53450	Recirculation Kit	R 851,30	R 979,00
LC67BB532 / LC64BA522	LZ53250	Recirculation Kit	R 851,30	R 979,00
LC67BB532 / LC64BA522	LC53251	Active Carbon Filter	R 851,30	R 979,00
LC98KD672 / LC67BB532 / LC64BA522 / LC94BBC50	LZ57000	CleanAir Recirculation Kit	R 4 251,30	R 4 889,00
LC98KD672 / LC67BB532 / LC64BA522 / LC94BBC50	LZ56200	CleanAir Active Carbon Filter	R 4 251,30	R 4 889,00
LC98KD672	LZ55850	Recirculation Kit	R 2 129,57	R 2 449,00
LC98KD672	LZ55651	Active Carbon Filter	R 851,30	R 979,00
LC98KPP60 / LC91KWP60 / LC67KHM60	LZ10AKU00	Recirculation Kit	R 642,61	R 739,00
LC98KPP60 / LC91KWP60 / LC67KHM60	LZ10AKT00	Recirculation Kit for chimless use	R 642,61	R 739,00
LC98KPP60 / LC97FQP60 / LC91KWP60 / LC67KHM60	LZ10AKA00	Active Carbon Filter	R 642,61	R 739,00
LC98KPP60 / LC97FQP60 / LC91KWP60 / LC67KHM60	LZ10AXC50	CleanAir Recirculation Kit	R 2 607,83	R 2 999,00
LC97FQP60	LZ10AFU00	Recirculation Kit	R 642,61	R 739,00
LC97FQP60	LZ10AFT00	Recirculation Kit for chimless use	R 642,61	R 739,00
LB75564 / LB54564	LZ73050	Recirculation Kit	R 433,91	R 499,00
LC94BBC50	LZ10DXU00	Recirculation Kit	R 642,61	R 739,00
LC94BBC50	LZ10DXA00	Active Carbon Filter	R 642,61	R 739,00
LC95KA670	LA10LKA6	Active Carbon Filter	R 807,83	R 929,00
LB53NAA50	LZ10INT00	Recirculating Kit	R 642,61	R 739,00
LB53NAA50	LZ10INA00	Active Carbon Filter	R 642,61	R 739,00

Accessories for cooking appliances

Part Number	Description	For model...	Price Incl. VAT*	Price Excl. VAT*
Oven Accessories				
HZ327000	Pizza Stone	HB633...,HB634...,HB636...,HN678...,HM656..., HS636... CM656...,CS658...	R 1 051,30	R 1 209,00
HZ634080	Wire Rack	HN678...,HM656...,CM656...	R 433,91	R 499,00
HZ664070	Wire Rack	HS636...,CS656...	R 433,91	R 499,00
HZ634070	Wire Rack	HB636...,HB634...,HB633...	R 433,91	R 499,00
HZ631070	Baking Tray, self-cleaning	HN678...,HB636...,HB634...,HB633...,HM656..., CM656...	R 468,70	R 539,00
HZ631010	Baking Tray, non-stick	CS658...,HS636...	R 468,70	R 539,00
HZ638200	2 level telescopic shelf rails, full ext	HB636...,HB634...,HB633...	R 1 164,35	R 1 339,00
HZ638300	3 level telescopic shelf rails, full ext	HB636...,HB634...,HB633...	R 1 233,91	R 1 419,00
flexInduction Accessories				
HZ390011	Roaster for flexinduction	For flexinduction 3 of 4 zones	R 2 103,48	R 2 419,00
HZ390012	Steam insert for flexinduction	For flexRoaster	R 1 051,30	R 1 209,00
HZ390512	Teppanyaki for flexinduction	Large (4 of 4 zones)	R 2 981,74	R 3 429,00
HZ390522	Grill plate for flexinduction	Large (4 of 4 zones)	R 2 120,87	R 2 439,00
HZ390050	Cooking Sensor	EX975KXW1E	R 781,74	R 899,00
HZ390090	Wok Set	EX975KXW1E	R 781,74	R 899,00
Gas Cooking Accessories				
HZ298105	Simmer plate for Gas		R 581,74	R 669,00
Accessories to Match Vario				
HZ394301	Joining Strip	all Varios	R 1 051,30	R 1 209,00
Hob Accessories				
HZ390230	Frying Sensor Pan		R 1 051,30	R 1 209,00
HZ390250	Frying Sensor Pan		R 1 320,87	R 1 519,00
HZ390042	Induction Pot Set (3 Pots, 1 Pan)		R 2 329,57	R 2 679,00



Cooling

The perfect environment for fresh food.

The perfect environment for fresh food.

Food preservation technologies mean you can store a lettuce for longer and it will taste as fresh as the day you bought it.



hyperFresh*

hyperFresh provides the ideal environment for your food, the hyperFresh storage system keeps your food fresh for as long as it needs to – Fresh for up to three times longer.



hyperFresh plus*

The new hyperFresh plus drawer doesn't just store fruit and vegetables, it provides them with the right conditions to keep them fresh for up to two times longer than usual. Whether it's fruits or vegetables, simply switch the control and the humidity will be adjusted for optimum storage of your food.



HyperFresh Premium*

The two hyperFresh premium 0°C drawers are especially designed for the cooling needs of fish and meat. Keep them fresher in ideal conditions near 0°C for up to two times longer. The separate compartments also avoid unpleasant smells to transfer and both boxes can be easily pulled out with one hand to make room for other foods and drinks, cooling them down quicker and providing refreshing drinks sooner.



Ideal storage for meat and fish*

Ideal for storing meat and fish, the coolBox creates an environment that is almost 3°C cooler than the rest of the fridge. The coolBox stores meat and fish at the optimum preservation temperature, whilst allowing other food in the fridge to be chilled at around 4°C. Food tastes better for longer and there is less food wastage.



No-frost technology*

Our refrigerator-freezer combinations and freezers with No-frost technology allow you to freeze and store food at all levels throughout the freezer compartment. Say goodbye to the inconvenience of rearranging your frozen foods – just freeze wherever there happens to be available space. In freezers and fridge/ freezer combinations equipped with No-Frost the cool air is distributed over the whole compartment by specific ventilation. The air is not as humid as warmer air and the thawed water evaporates outside the fridge. The result is dry cool air and no ice on side panels, rear or food. You do not have to defrost your freezer anymore.



freshSense*

This technology ensures longlasting freshness in fridges and freezers. Smart electronic modules linked to up to five sensors constantly cross-check the outside and inside temperatures. They balance out temperature fluctuations and thus keep the refrigeration of the food steady.



Electronic temperature control*

The temperature is controlled accurately. The temperature that is displayed on an exterior display will give the correct information about the temperature inside the appliance.



10 year warranty*

A 10 year warranty on your compressor will give you additional piece of mind when purchasing a fridge.

*Selected models only



Model	KI85NAD30G	KI86SAF30
Product description	iQ500 246 litre integrated no frost fridge freezer combination coolEfficiency	iQ500 265 litre integrated low frost fridge freezer combination coolEfficiency
Product features	<ul style="list-style-type: none"> *** Freezer 100% CFC/HFC free Touch control - 7 segment electronic control freshSense - constant temperature by intelligent sensor technology No frost freezer Two Cooling Systems SUPER cool function SUPER freezing with automatic switch off Acoustic open door warning system Optical and Acoustic Warning System by Temperatur increase, with memory function Holiday mode Freezing capacity: 9 kg/24 hours Storage time in event of power failure: 13 hours Door right hinged, reversible 	<ul style="list-style-type: none"> *** Freezer 100% CFC/HFC free Touchcontrol – 7 segment control freshSense - constant temperature by intelligent sensor technology Low frost freezer Two Cooling Systems SUPER cool function SUPER freezing with automatic switch off Acoustic open door warning system Optical and Acoustic Warning System by Temperatur increase, with memory function Holiday mode Freezing capacity: 7kg in 24 hours Storage time in event of power failure: 32 hours Door right hinged, reversible
Interior features of fridge section	<ul style="list-style-type: none"> LED interior light in fridge section 4 safety glass shelves (3 height adjustable), of which 1 x varioShelf divisible and pushed under shelf, 1 extendable easyAccess shelf hyperFresh Box with humidity control - keeps fruit and vegetables up to 2 x longer fresh 	<ul style="list-style-type: none"> Extremely bright interior light 5 safety glass shelves(4 height adjustable) of which 1 x varioShelf divisible and 1 extendable easyAccess shelf 5 door bins, there of 1 x dairy compartment hyperFresh Plus Box with humidity control – keeps fruit and vegetables up to 2 x fresher
Interior features of freezer section	<ul style="list-style-type: none"> Vario Zone - removable safety glass shelves for extra space! 4 transparent freezer drawers, incl.1 bigBox 	<ul style="list-style-type: none"> Vario Zone - removable safety glass shelves for extra space! 3 transparent freezer drawers including 1 bigBox
Product specs	<ul style="list-style-type: none"> Rating: 90W Capacity top fridge: 154 litres net Capacity bottom freezer: 92 litres net Energy consumption: 232 kWh/yr Overall (H x W x D): 177.2 x 55.8 x 54.5 cm Aperture (H x W X D): 177.5 x 56.0 x 55.0 cm 	<ul style="list-style-type: none"> Rating: 90W Capacity top fridge: 191 litres net Capacity bottom freezer: 74 litres net Energy consumption: 218 kWh/yr Overall (H x W x D): 177.2 x 55.8 x 54.5 cm Aperture (H x W x D): 177.5 x 56.0 x 55.0 cm
Barcode	4242003612590	4242003583944



Model	KI42FP60	GI38NP60
Product description	iQ700 320 litre built-in full fridge coolConcept	iQ700 237 litre built-in full freezer coolConcept
Product features	<ul style="list-style-type: none"> 100% CFC/HFC Free Auto Defrost Dynamic Cooling SUPER cool function Electronic temperature control, touch control Acoustic alarm Soft close door Door right hinged, reversible Complete ventilation through plinth 	<ul style="list-style-type: none"> *** Freezer 100% CFC/HFC Free No Frost Freezer Electronic temperature control, touch control SUPER freeze function with automatic switch off function Acoustic/Visual alarm Soft close door Storage time in event of power failure: 11 hours Freezing capacity: 25kg in 24 hours Door left hinged, reversible Complete ventilation through plinth
Interior features of fridge section	<ul style="list-style-type: none"> 4 full extension storage trays 1 Divider Box Bottle Rack 4 Door bins Dairy compartment Internal LED light 7 safety glass shelves of which 3 are height adjustable, 1 EasyLift glass shelf 	
VitaFresh section	<ul style="list-style-type: none"> 1 Vegetable container with humidity control with wave bottom, 25 litre. 2 hyperFresh 0°C drawers for fish and meat 	
Interior features of freezer section		<ul style="list-style-type: none"> 2 Hinged freezer compartments with transparent front 5 Freezer drawers, incl. 1 Big Box 6 Security glass shelves between freezer drawers LED illumination
Product specs	<ul style="list-style-type: none"> Rating: 120W Capacity: 302 litres net Unit dimensions (H x W x D): 177.2 x 55.6 x 54.5cm Energy consumption: 121 kWh/yr Aperture (H x W x D): 177.5 x 56.0 x 55.0cm 	<ul style="list-style-type: none"> Rating: 120W Capacity: 213 litres net Unit dimensions (H x W x D): 177.2 x 55.6 x 54.5cm Energy consumption: 222 kWh/yr Aperture (H x W x D): 177.5 x 56.0 x 55.0cm
Barcode	4242003462294	4242003462119



Model	KI18RV51	KU15RA65
Product description	iQ100 151 litre fully integrated bar fridge, not to be built-under	iQ500 141 litre fully integrated bar fridge
Product features	100% CFC/HFC free Anti Bacteria – permanent barrier against fungi for fresher foods Automatic defrost Door right hinged, reversible Interior with metal applications	100% CFC/HFC free Automatic defrost Door right hinged, reversible Ventilation in the plinth, no ventilation cut-out in the work surface necessary Variable plinth adaption Height adjustable feet Soft close door
Interior features	4 safety glass shelves of which 3 are height adjustable, 1 divisible 1 Vegetable compartment Variable inner door with dairy compartment Bottle holder	3 safety glass shelves of which 3 are height adjustable 1 Vegetable compartment Variable inner door with dairy compartment Bottle holder Interior with metal applications LED interior light
Product specs	Rating: 90W Capacity: 151 litres net Energy consumption: 122 kWh/yr Overall (H x W x D): 87.4 x 54.1 x 54.2cm	Rating: 90W Capacity: 141 litres net Energy consumption: 92 kWh/yr Overall (H x W x D): 82.0 x 59.8 x 54.8cm Aperture (H x W x D): 82.0 x 60.0 x 55.0cm
Barcode	4242003466377	4242003553350

Dishwashing

Innovations for extra shine.



Saving energy naturally.

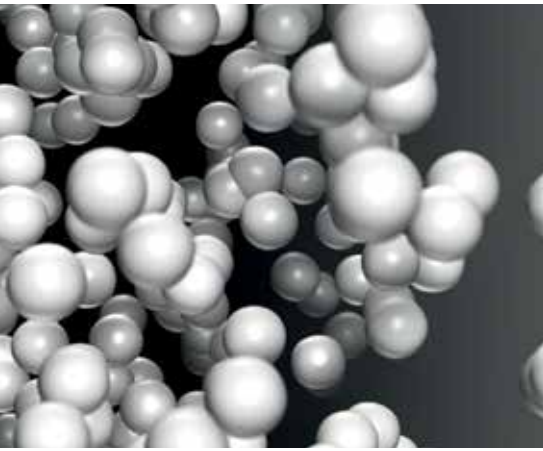

Using advanced drying technologies, Siemens dishwashers keep energy consumption to a minimum. Zeolith®, a naturally occurring mineral, has the astonishing ability to absorb moisture and convert it to heat.

What does this mean for you? The heat produced naturally by the Zeolith® is used for the drying cycle. No additional energy is therefore required to heat up the contents of your dishwasher for the drying process (as with a standard drying system). This results in perfect drying, with less energy usage.

The Zeolith® mineral is stored in the depths of the dishwasher; this regenerates itself and keeps working for the entire lifetime of the machine. Combine this with the economy 50 programme to get brilliant results with minimal energy.



Add an extra shine

Shine & Dry is a unique energy efficient function that produces table ready, gleaming glassware by harnessing the power of Zeolith®.

This special drying cycle not only brings out a streak free shine in most delicate glassware and tableware but also means extra dry and stain free plastics, pots and pans.

Add an extra shine - Zeolith® absorbs moisture and converts it to heat energy.

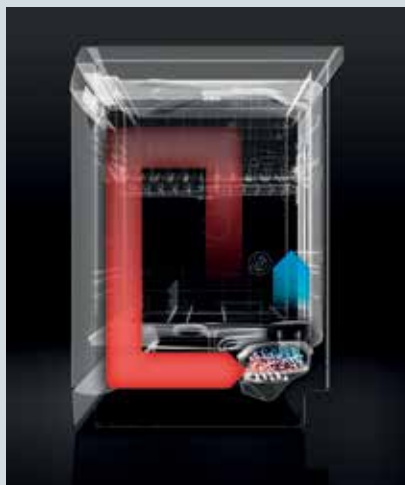

Add an extra shine - As the mineral is heated during the cleaning cycle, it is recharged and ready to absorb moisture once more.

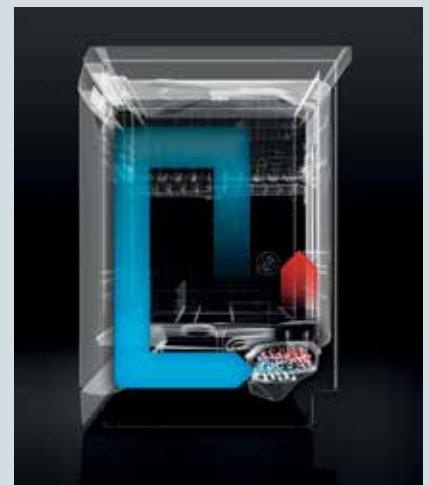

Clean dishes before the evening is over.



Intensive zone*

New Intensive Zone option is the solution for mixed loads. Heavily soiled and delicate dishes are perfectly cleaned in the same cycle. The entire lower basket is converted into a heavy duty cleaning zone by increasing water pressure and the cleaning temperature in the lower basket, whilst water pressure stays according to the selected program in the upper basket.

Delicate

Intensive



Ever needed your dishes cleaned quickly, forgotten to put the dishwasher on in the morning, or simply need clean plates before your guests arrive?



VarioSpeed Plus*

That's why we've introduced varioSpeed Plus, the perfect time saver. Giving you the flexibility to spend time on more important things, varioSpeed Plus reduces the time it takes to wash and dry a full load down to a third. Ideal when you need your cutlery and plates in a hurry, just press the varioSpeed Plus button in conjunction with your desired programme* and it will run the dishwasher significantly faster without compromising on wash quality. Used together with the Eco 50 programme, varioSpeed Plus will wash and dry a full load in just over an hour. Giving you time saving solutions when you need them the most and sparkling clean dishes fast.

*Not possible for all programmes



Dosage Assist*

Reliable cleaning everytime. Special tray for desolving of detergent tabs. Convenient loading of detergent, controlled and fast dissolving everytime. Clean handling.



Vario Drawer*

More loading capacity with Vario Drawer 12+2=14, extra room for small dishes and bigger cutlery items. Easy loading of wine glasses in the upper basket.



varioHinge*

The varioHinge is the optimal solution for the smallest possible gaps between the front panels of kitchen units, low base dimensions and high countertop levels. With appliances featuring the varioHinge the fully integrated front panel moves up slightly when the machine is opened. This does away with large gaps when dishwashers are installed at a high level. You can also forget about collisions with the base and floor pan.



MachineCare*

The Machine Care programme is used to remove grease and limescale from the dishwasher interior with the assistance of a standard machine-care-detergent. The programme run time is 90 min with medium to high water temperatures.

*Selected models only



Model	SN678X02TE	SN758X01TH
Product description	iQ700 60 cm speedMatic fully integrated dishwasher 6 temperatures	iQ700 60 cm speedMatic fully integrated dishwasher, varioHinge 5 temperatures
Programmes	Auto 35-45°C, Auto 45-65°C, Auto 65-75°C, Eco 50°C, Night Program 50°C, Glass 40°C, Quick Wash 45°C, Pre Rinse Special functions: Shine & Dry, IntensiveZone, varioSpeed Plus, HalfLoad, HygienePlus	Intensive 70°C, Auto 45-65°C, Eco 50°C, Silence 50°C, Glass 40°C, 1hr 65°C, Quick 45°C, Pre Rinse Special functions: Intensive Zone, varioSpeedPlus, HygienePlus, ExtraDry, Machine Care Programme
Comfort and safety	Number of standard place settings: 14 speedMatic hydraulic system Zeolite-Drying dosageAssist iQdrive Aqua-Sensor, Load-Sensor Detergent Automation Heat Exchanger – for hygienic drying, prevents thermal shock Glass care protection system Alternating spray technique Self-cleaning filter system with 3-fold corrugated filter High-definition colour TFT display showing graphic symbols and plain text metalTouch operation emotionLight Acoustic end of cycle indicator timeLight Real-time clock Electronic delay timer: 1-24 hours LED salt and rinse aid refill indicator varioFlex Pro basket system with blue coloured touchpoints varioDrawer Pro rackMatic height-adjustable top basket (3 stage) Childproof door lock Dishwasher cavity: Stainless Steel aquaStop with guarantee against flooding	Number of standard place settings: 14 speedMatic hydraulic system dosageAssist iQdrive AquaSensor, Load-Sensor Detergent Automation Heat Exchanger – for hygienic drying, prevents thermal shock Glass care protection system ecoDrying Electronic delay timer: 1-24 hours, and time remaining display LED salt and rinse aid refill indicator metalTouch operation(black) High-definition colour TFT display showing graphic symbols and plain text Acoustic end of cycle indicator infoLight Self-cleaning filter system with 3-fold corrugated filter varioDrawer Pro varioFlex Pro basket system Rackmatic height-adjustable top basket (3 stage) Glass rack in bottom basket Dishwasher cavity: Stainless Steel aquaStop with guarantee against flooding
Product specs	Overall (H x W x D): 81.5 x 59.8 x 55.0cm Aperture (H x W x D): 81.5 – 87.5 x 60.0 x 55.0cm Consumption rate: Eco 50C/9.5l/0.83kWh/195min Rating: 2400W Noise level: 42dB	Dimensions (H x W x D): 81.5 x 59.8 x 55.0 cm Aperture (H x W x D): 81.5 – 81.7 x 60.0 x 55.0 cm Consumption rate: Eco50C/9.5l/0.93kWh/195min Rating: 2400 W Noise level: 41dB
Barcode	4242003685708	4242003793206



Model	SN636X031E
Product description	iQ300 60cm speedMatic fully integrated dishwasher 5 temperatures
Programmes	Intensive 70°C, Auto 45-65°C, Eco 50°C, Glass 4°C, 1h 65°C, Pre rinse Special functions: varioSpeed Plus, IntensiveZone, extraDry
Comfort and safety	<ul style="list-style-type: none"> Number of standard place settings: 13 speedMatic hydraulic system dosageAssist iQdrive Aqua-Sensor, Load-Sensor Detergent Automation Heat Exchanger – for hygienic drying, prevents thermal shock Glass care protection system Alternating spray technique Self-cleaning filter system with 3-fold corrugated filter Electronic delay timer (1-24 hours) and time remaining display Acoustic end of cycle indicator infoLight LED salt and rinse aid refill indicator varioFlex basket system Height adjustable top basket with 3 stage rackMatic Childproof door lock Dishwasher cavity: Stainless Steel aqua Stop with guarantee against flooding
Product specs	<ul style="list-style-type: none"> Dimensions (H x W x D): 81.5 x 59.8 x 55.0cm Aperture (H x W x D): 81.5 – 87.5 x 60.0 x 55.0 cm Consumption rate: Eco50°C/9.5l/0.92kWh/210min Rating: 2400 W Noise level: 44dB
Barcode	4242003767221

Installation diagrams

OVENS

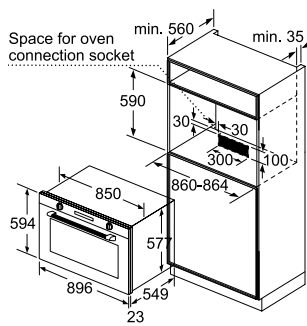

VB554DFR0

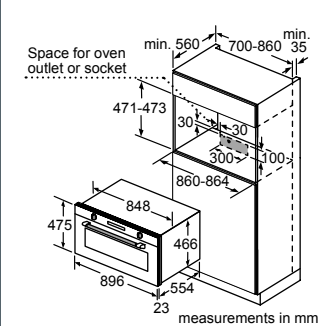

VB554CCR0

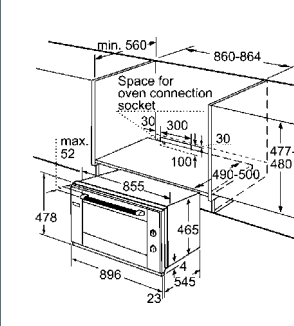

HV541ANS0

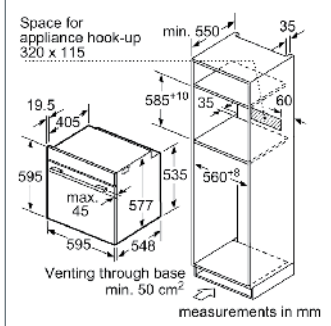

HN678G4S1

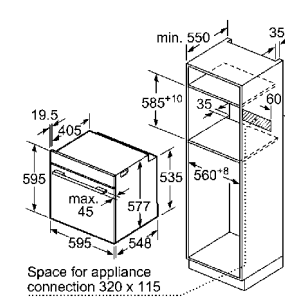

HS636GDS1

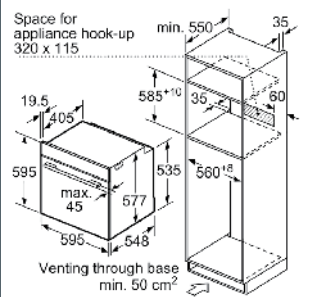

HM656GBS1

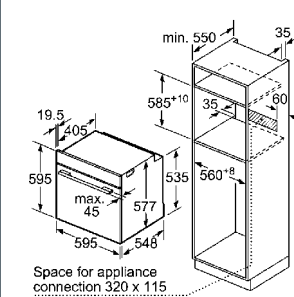

HB633GBS1/HB634GBS1/HB636GBS1

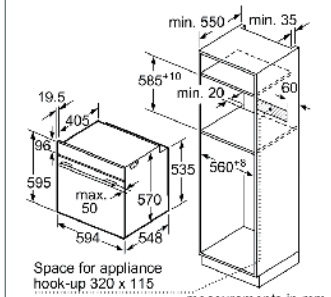

HB557G4S0

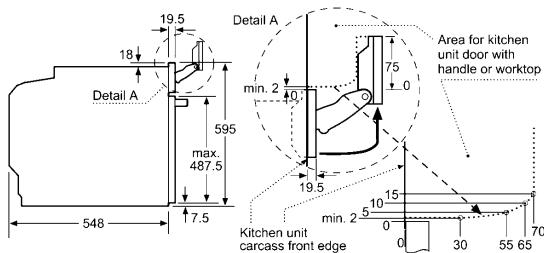

Note the pivoting range of the fascia.

HN678G4S1 / HS636GDS1

COMPACT APPLIANCES

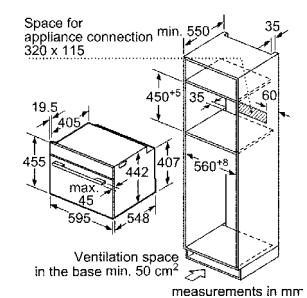

CM656GBS1

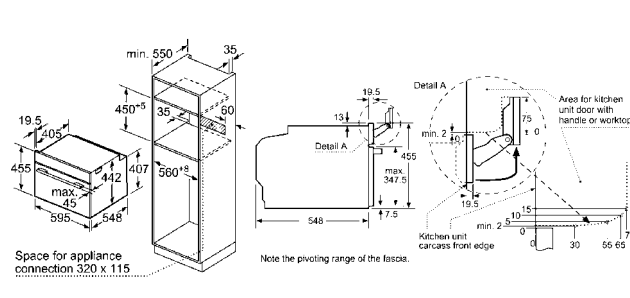

CS658GRS1

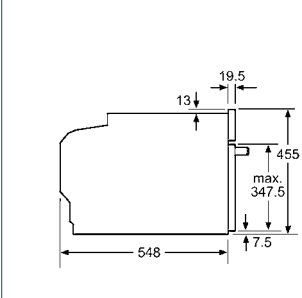

CM656GBS1 / CS658GRS1

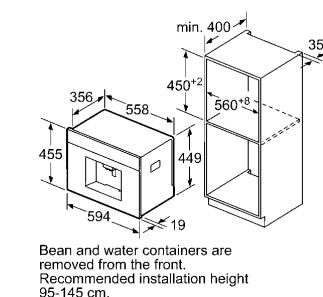

CT636LES1

Left corner installation

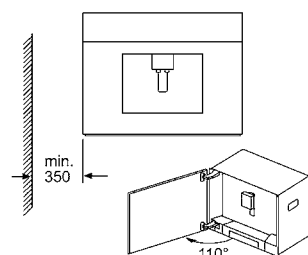

MICROWAVE OVENS

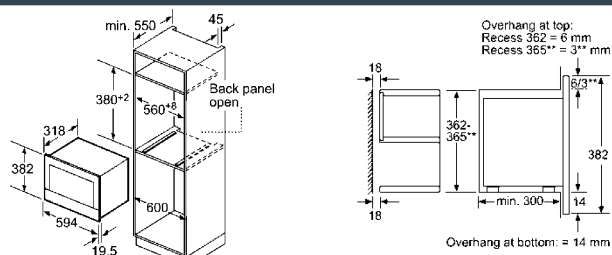

BE634RGS1 / BE634LGS1

MICROWAVE OVENS

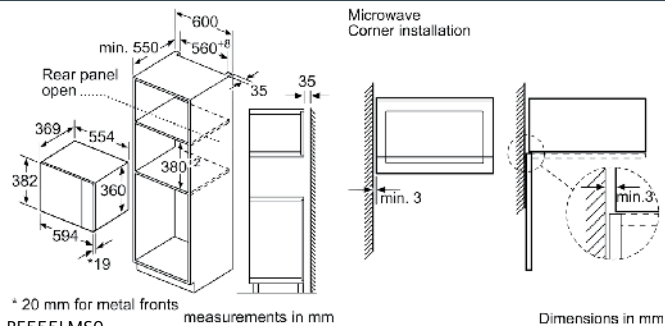

* 20 mm for metal fronts
BE555LMS0 measurements in mm

Dimensions in mm

WARMER DRAWERS

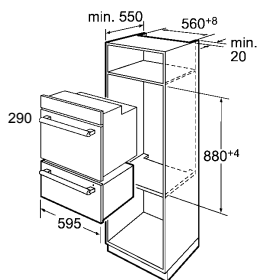

BI630DNS1

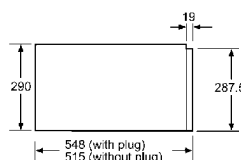

Ovens with an appliance height of 595 mm can be installed above a warming drawer. An intermediate floor is not required.

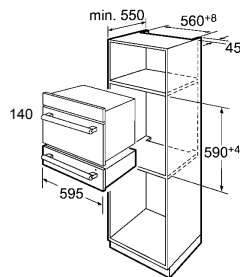

BI630CNS1

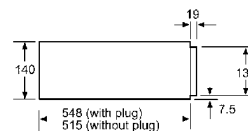

Compact ovens with an appliance height of 455 mm can be installed above a warming drawer. An intermediate floor is not required.

INDUCTION HOBS

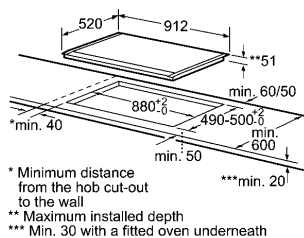

EX975LVC1E

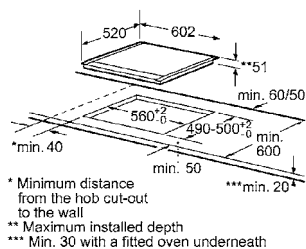

EX675LEC1E*

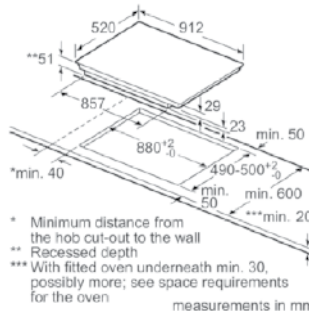

EX975KXWIE

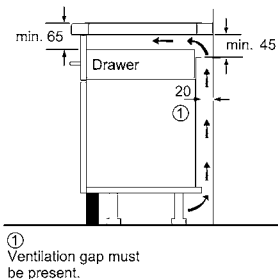

*For all induction hobs

HOBS

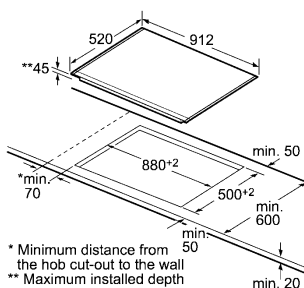

ET975LMP1D

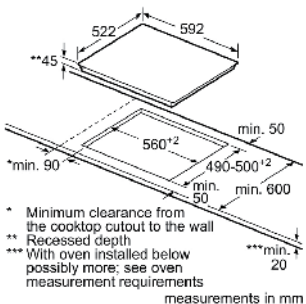

ET611HE17E

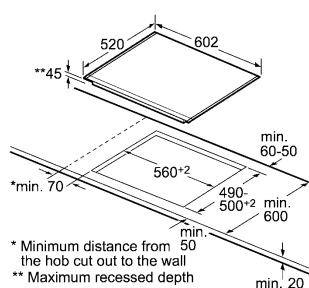

ET675FNP1E / ET67517E

DOMINO HOBBS

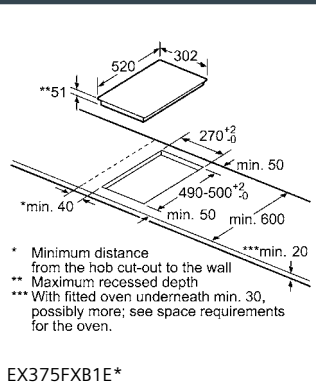

EX375FXB1E*

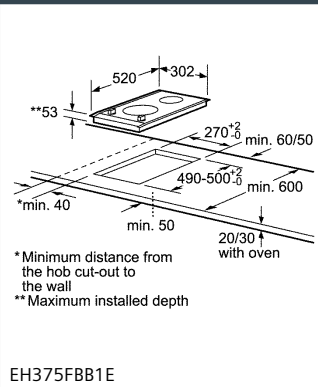

EH375FBB1E

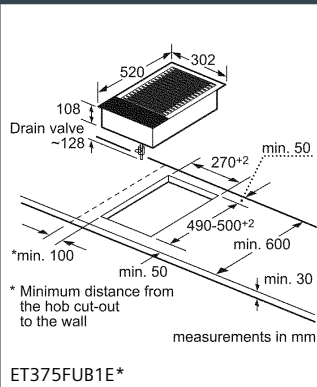

ET375FUB1E*

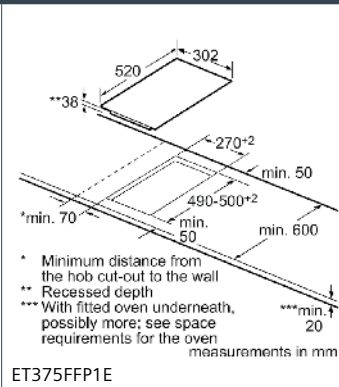

ET375FFP1E

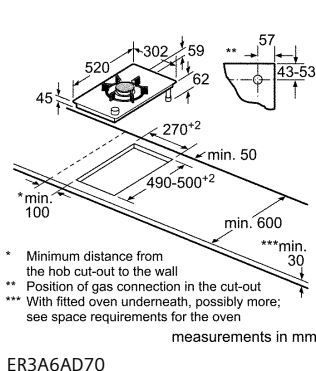

ER3A6AD70

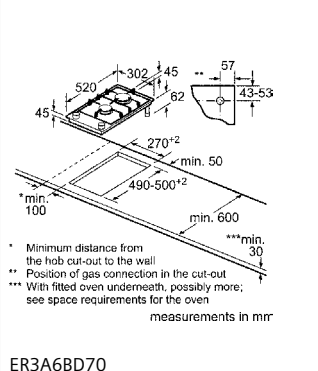

ER3A6BD70

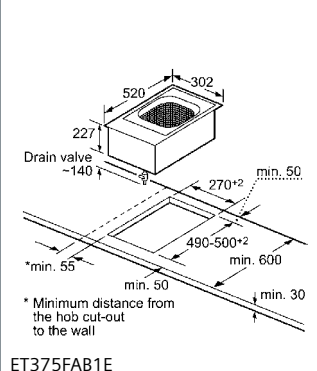

ET375FAB1E

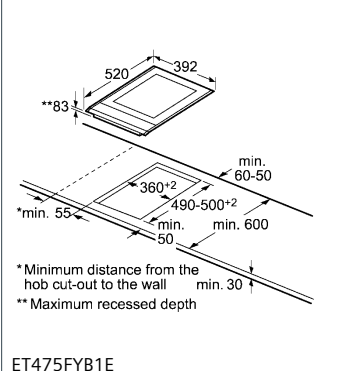

ET475FYB1E

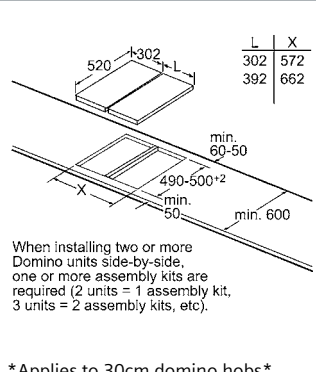

* Applies to 30cm domino hobs*

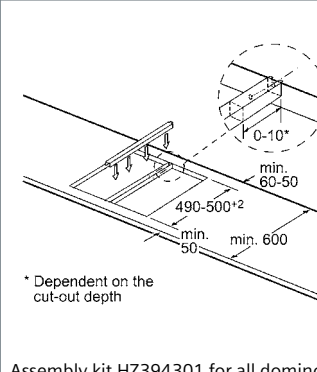
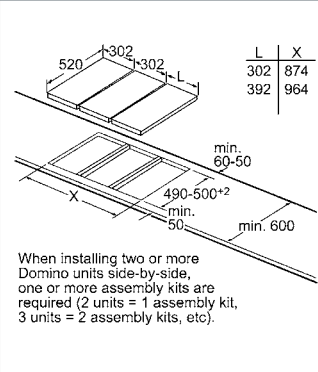

Assembly kit HZ394301 for all domino hobs

GAS HOBBS / STEPFLAME

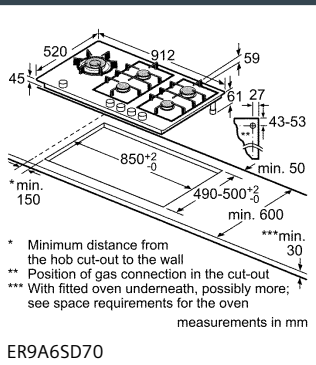

ER9A6SD70

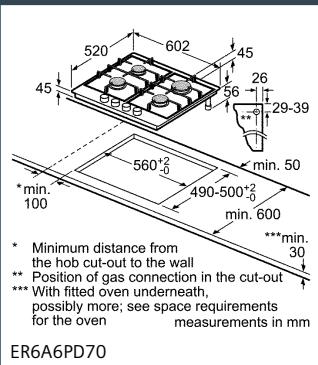

ER6A6PD70

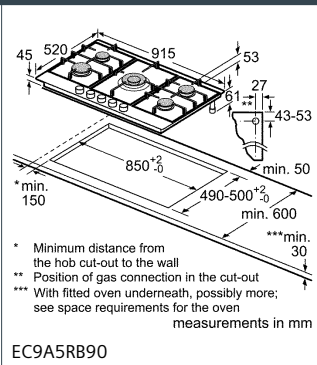

EC9A5RB90

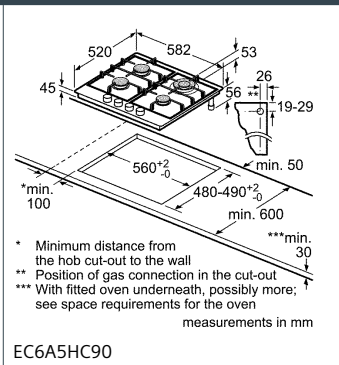

EC6A5HC90

EXTRACTORS

LD97AA670B

Use with gas hob: Maximum total power 12.4 kW

* 650 mm depth only in combination with slim hobs.
** min. 750 mm for hobs with 500 mm cut-out depth.

LF21BA552

* from upper edge of pan support

LF98BC542

* from upper edge of pan support

LF98BB542

* from upper edge of pan support

LC94BBC50

(1) Exhaust air
(2) Circulated air
(3) Air outlet – slots for exhaust air to be mounted facing down

LC97FQP60

(1) Exhaust air
(2) Circulated air
(3) Air outlet – slot for exhaust air mounted facing down

Appliance in circulated air mode without duct. Circulated air set required. measurements in mm

(1) Position of socket. Note the maximum thickness of the back panel. measurements in mm

min. 450 electric min. 600 gas*
* from upper edge of pan support

LC95KA670

(1) Exhaust air (2) Circulated air
(3) Air outlet – slots for exhaust air to be mounted facing down

LB75564

measurements in mm

LB53NAA50

measurements in mm

EXTRACTORS

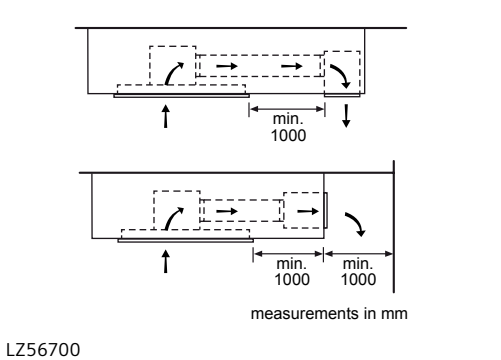
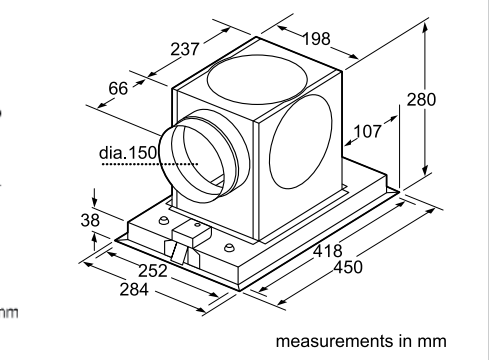
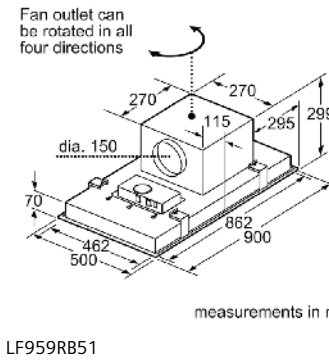
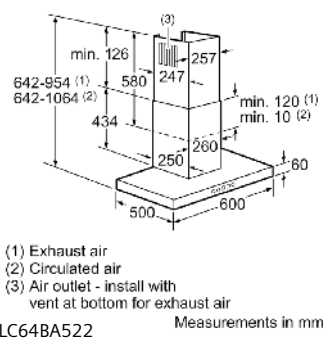
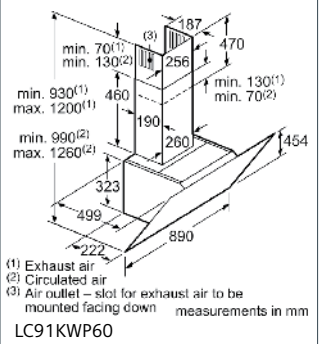
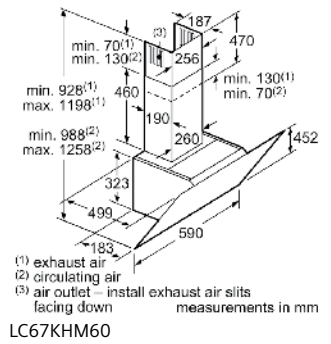
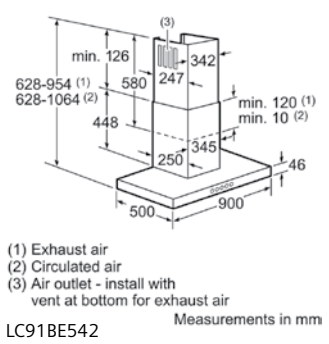

COOLING

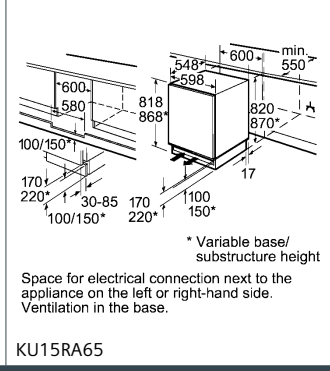
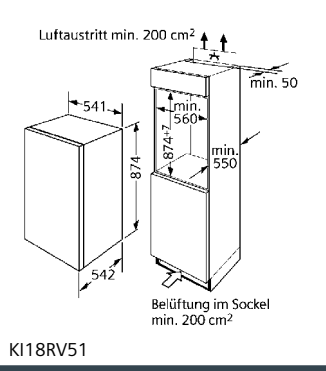
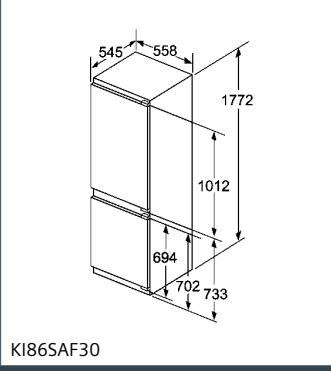
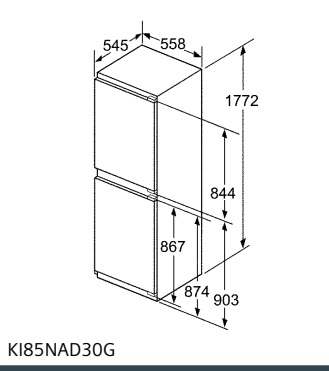
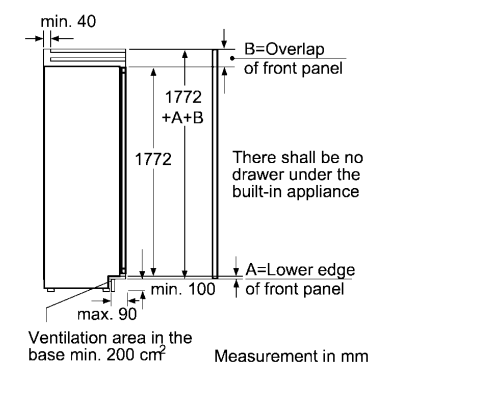
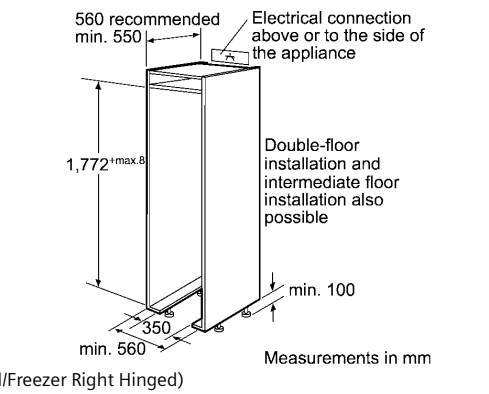
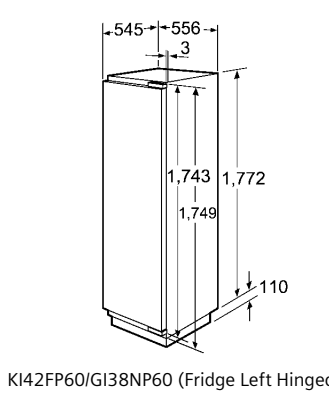

DISHWASHERS

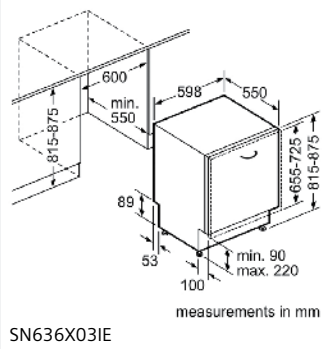
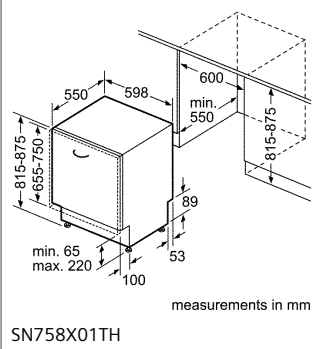
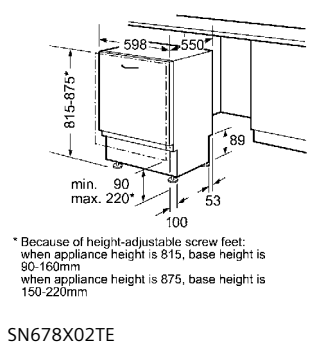

Guarantee Conditions

Guarantee is not valid if appliances are used in an industrial application. Appliance must be installed by a licensed tradesman according to BSH and national or local regulations.

Total guarantee period for built-in appliances: 5 years from date of purchase.

Total guarantee period for CT636LES1 coffee machine: 3 years from date of purchase.

Transport damages will only be accepted 7 days after delivery to end user or contractor working on behalf of end user (kitchen company, building contractor).

First year full guarantee on parts and labour – excluding very fragile parts i.e. glass, plastic, light bulbs.

Second and third year on functional parts only: electronics, timers, switches, locks, clocks, thermostats, fans plus labour to repair or replace.

Fourth and fifth year on functional parts only: electronics, timers, switches, locks, clocks, thermostats, fans plus labour to repair or replace.

After guarantee expires, customer must pay a current call out fee towards labour costs.

Condition governing appliance service

1. A guarantee claim ceases once repair or work is undertaken by a person not entitled by BSH to do so or if the appliance is provided with spare parts, attachments or accessories that are not original, therefore causing damage.
2. The guarantee is given in such a manner that defective parts are repaired free of charge or – and this is BSH choice – replaced by perfect parts.
3. A claim under guarantee does not cause an extension of the guarantee period nor does it start a new guarantee period.
4. If BSH refuses repair or repair fails and the end user so requires, a replacement of equal value is supplied free of charge within the above guarantee period.
5. These conditions of guarantee are applicable to appliances purchased in South Africa. If appliances are taken abroad and meet the technical requirements (e.g. voltage, frequency, type of gas etc) of such country while also being suitable for the respective climate and environmental conditions, these terms of guarantee are applicable only if BSH have an approved customer service network in such country.

* Valid from February 2008



Customer Service



Built-in Appliances

Total guarantee period: 5 years from date of purchase.
Terms and conditions apply.



BSH Service Centre

Tel: 0860 026 724
Fax: 0861 171 780
E-mail: bsh@iopen.co.za

Guarantee Conditions

Guarantee is not valid if appliances are used in an industrial application. Appliance must be installed by a licensed tradesman according to BSH and national or local regulations.

Total guarantee period for built-in appliances: 5 years from date of purchase.

Total guarantee period for CT636LES1 coffee machine: 3 years from date of purchase.

Transport damages will only be accepted 7 days after delivery to end user or contractor working on behalf of end user (kitchen company, building contractor).

First year full guarantee on parts and labour – excluding very fragile parts i.e. glass, plastic, light bulbs.

Second and third year on functional parts only: electronics, timers, switches, locks, clocks, thermostats, fans plus labour to repair or replace.

Fourth and fifth year on functional parts only: electronics, timers, switches, locks, clocks, thermostats, fans plus labour to repair or replace.

After guarantee expires, customer must pay a charge of R430 excl. VAT (annual increase applies) towards labour costs.

Condition governing appliance service

1. A guarantee claim ceases once repair or work is undertaken by a person not entitled by BSH to do so or if the appliance is provided with spare parts, attachments or accessories that are not original, therefore causing damage.
2. The guarantee is given in such a manner that defective parts are repaired free of charge or – and this is BSH choice – replaced by perfect parts.
3. A claim under guarantee does not cause an extension of the guarantee period nor does it start a new guarantee period.
4. If BSH refuses repair or repair fails and the end user so requires, a replacement of equal value is supplied free of charge within the above guarantee period.
5. These conditions of guarantee are applicable to appliances purchased in South Africa. If appliances are taken abroad and meet the technical requirements (e.g. voltage, frequency, type of gas etc) of such country while also being suitable for the respective climate and environmental conditions, these terms of guarantee are applicable only if BSH have an approved customer service network in such country.

* Valid from February 2008

Midrand

Private Bag X36
Randjespark
Halfway House 1685
Rep. of South Africa
Tel: 011 265 7800
Fax: 011 265 7817

**BSH Brand Experience Centre
Johannesburg**

30 Archimedes street
Kramerville 2148
Tel: 010 001 0019

**BSH Brand Experience Centre
Cape Town**

17 New Church Street
Bree Street Studios
Cape Town 8000
Tel: 021 550 9900

siemens-home.bsh-group.com/za/

BSH Group is a Trademark Licensee of Siemens AG.

Please note that certain features apply to particular products.
Siemens built-in appliances are guaranteed for 5 years and
CT636LES1 coffee machine for 3 years from date of purchase
against faulty workmanship and/or material.
No responsibility is accepted for printing errors. E&OE.