

Appliances that Lead the Way to Exceptional
**DIGITAL KITCHEN DESIGN
& PLANNING GUIDE**

Featuring New 2017–2018 Product Additions



Thermador 

THERMADOR.COM

Updated 11/17

INSIDE

INTRODUCTION 4



RANGES
Pro Grand® 12
Pro Harmony® 56



RANGETOPS
96



BUILT-IN MICROWAVES
312



WARMING DRAWERS
298



COOKTOPS
Induction 154
Gas 174
Electric 188



DISHWASHERS
418



REFRIGERATION
Freedom 324
Under-Counter 402



BUILT-IN OVENS
116



VENTILATION
Overview 202
Wall Hoods 226
Chimney Wall Hoods 248
Island Hoods 262
Custom Inserts 272
Downdraft 290



BUILT-IN COFFEE MACHINE
440

PRODUCT INDEX	446
EXPERIENCE THERMADOR®	448
WARRANTY	449

COVER KITCHEN DESIGN BY: JON DE LA CRUZ
LOG ON TO THERMADOR.COM FOR THE MOST CURRENT
KITCHEN DESIGN AND PLANNING SPECIFICATIONS



Thermador 

Appliances That
**LEAD THE WAY
TO EXCEPTIONAL**

The very essence of Thermador is defined by our insatiable desire to be better than we were yesterday; we are never finished improving. We foster meaningful connections with those who create beautiful homes with our products, allowing us to inspire one another.

In everything we do, we build upon our three brand pillars: innovation, design, and performance. We design our products with aesthetics at top of mind without compromising function, so every product we craft allows our consumers to express themselves through cooking. We help bring unique visions to life with personalization, bespoke solutions, and flexibility that won't be found elsewhere. Any kitchen can be beautiful, but only a Thermador kitchen can be exceptional.



A Century IN THE MAKING

1916. A time of Model T's, two-cent postage stamps and the beginnings of a company that would reshape the kitchen industry forever—Thermador®.

Our passion for innovation and high performance started in the manufacturing of electric appliances and rapidly sparked new life in the hardest working room of the home, the kitchen. A century later, that commitment to quality and craftsmanship can be experienced in our world-class cooking, refrigeration and dishwasher collections, considered by many to be the pinnacle of luxury in today's kitchens.



- 1916:** Thermador is founded.
- 1932:** William E. Cranston Jr. and H.H. Fogwell merged their independent companies, forming the Thermador Electrical Manufacturing Company.
- 1942:** Thermador engineered new ways to seal and protect electronics from extreme temperatures and humidity—an important invention at this time as the use of electronics grew in foreign countries with severe climate conditions.
- 1951:** Thermador introduced the first "Bilt-In" Griddle.
- 1952:** Thermador introduced the first Electric Cooktop with "Bilt-In" Griddle.

- 1952:** Thermador introduced the "Bilt-In" Warming Drawer.
- 1955:** Thermador introduced the first "Bilt-In" Wall Oven with a Warming Drawer and stainless combination.
- 1956:** Thermador was selected as the choice brand used in Eichler homes to reinvent the modern kitchen as part of Eichler's bold new-concept homes during the Post-Retro Modern Movement.
- 1956:** Thermador introduced the first "Bilt-In" Double Wall Oven, a 'side-by-side.'
- 1957:** Thermador introduced their "Bilt-In" Refrigerator-Freezer, labeled as the masterpiece in its field.

- 1959:** Thermador published the first Kitchen Planning Guide, an essential tool that helped people efficiently design and build their kitchen.
- 1962:** Thermador introduced the first all stainless steel Dishwashers, including first tub Dishwashers with a multi-filter system, dual motor and pump for quieter operation.
- 1962:** Thermador offered convenience in cooking with the 2-compartment Warming Drawer, each with separate adjustable thermostats.
- 1963:** Thermador continued to improve the modern kitchen by rolling out the first Self-Cleaning Oven.

- 1964:** The first Electric Cooktop with a hinged top was released to make cleaning easier.
- 1965:** To give designers and cooks a new option for the kitchen, Thermador released black glass Oven door fronts.
- 1970:** Thermador continued to introduce innovative kitchen appliances, which included the first "SmoothTop" Cooktop, using materials developed by Corning Incorporated.
- 1975:** Thermador introduced the first "Browning" Microwave and an Oven/Micro Combo Unit.
- 1976:** Thermador launched the new Rotisserie feature to the Cooktop.

- 1978:** America got its first look at a retractable pop-up Downdraft Ventilation System, which offered a concealed look and made ventilation possible for any kitchen.
- 1982:** Thermador continued to set industry standards with the first high-power Super Burner, offering 11,500 BTUs output, an unmatched achievement for its time.
- 1987:** Thermador introduced the first gas Cooktop with sealed burners and Automatic Gas Re-Ignition.
- 2002:** Thermador produced the first domestic Jet Impingement Oven, a technology that improves "Speedcooking" by using 60 MPH variable directed jets of air, along with microwave radiation, to reduce cooking time by 75 percent.

- 2008:** Thermador introduced SensorDome® technology, which automatically measures temperature in cookware.
- 2016:** 100 years of innovation.
- 2017:** Thermador introduced Liberty™ Induction Cooktops featuring HeatShift™ and MoveMode™, which allow cooks to move around their cookware during meal prep.



THE MAN BEHIND THE BRAND AND INDUSTRY
Founded by William E. Cranston Jr., Thermador began as a manufacturer of electric items, most notably portable and "Bilt-In" Heaters.

THE INTRODUCTION OF AUTOMOTIVE AIR COOLERS
In the late 1930s, Thermador expanded to cooling with the introduction of the first "Evaporative Coolers," followed by room coolers and later adapted its home "Swamp Cooler" to produce Automotive Air Coolers.

THE FIRST "BILT-IN" APPLIANCES
Thermador introduced "Bilt-In" Appliances at a world exhibition billed as "The Kitchen of the Future."

THE FIRST "PRO" RANGE
Thermador introduced the first "Pro" Range, a 48" stainless steel 6 burner with Dual Ovens.

COOKTOP CONFIGURATIONS
Thermador introduced the first Electric "Cooktops" with Specialty Multiple Element configurations and established industry standards for cooktop sizes 30", 34", 36" and 45".

INTRODUCED FIRST SPEED COOKING OVEN
Thermador introduced the first "Speedcooking" Oven, which combined thermal heat with Microwave energy to cook food up to 35 percent faster than conventional Ovens.

INTRODUCED STAR® BURNER
Thermador introduced the first Professional Ranges and Cooktops with the exclusive, patented Star® Burner.

INTRODUCED CONVECTION WARMING DRAWER
Thermador introduced America to the first Warming Drawer with convection technology that circulates air for quick and even heating.

INVENTED FIRST PRO GRAND® STEAM RANGE
The Pro Grand Steam Range made its debut as the only Range with a Built-In Steam Convection Oven.

INVENTED FREEDOM® INDUCTION COOKTOP
Thermador introduced the Freedom® Induction Cooktop, with the largest, fully-usable cooking surface.

THERMADOR TURNS 100 YEARS OLD
A milestone in company history, we celebrate a century of innovation and quality craftsmanship in world-class kitchen appliances.

A COMPLETELY REFRESHED REFRIGERATION COLLECTION
Thermador launches a new Freedom® Collection featuring customizable interiors and introduces its largest capacity culinary preservation columns: 36-inch single-door refrigerator and freezer columns.

1916

1930

1930

1930

1940

1947

1950

1950

1955

1957

1976

1994

1998

2006

2006

2010

2011

2012

2012

2015

2016

2016

2017

2017

THE INTRODUCTION OF ELECTRIC SPACE HEATERS
In the early 1930s, Thermador produced the "Skyscraper," an Art Deco line of Electric Space Heaters and Wall Heaters.

THE LAUNCH OF COOKING PRODUCTS
In the late 1930s, Thermador launched Cooking Products. Thermador also invented and brought to market the first Electric Storage Water Heater.

THE FIRST WALL OVEN WITH MATCHING COOKTOP
Thermador introduced the first "Stainless Kitchen" and produced the world's first "Bilt-In" Wall Oven with a matching "Bilt-In" Cooktop.

THE "NORRIS" ARTIFACTS & GREEN MOVEMENT
Thermador Electric Company was acquired by Norris Industries and renamed Norris-Thermador Corporation. During this period, Thermador produced Thermador security badges and other artifacts from leftover metals used in the manufacturing of appliances.

STAINLESS AND COLOR KITCHEN
Thermador introduced "Stainless & Color" Kitchen styling. Stainless was paired with five popular colors.

INTRODUCED EXTRALOW® BURNER
Thermador introduced exclusive ExtraLow® Burners, which cycle the flame on and off to maintain heat as low as 100°—perfect for melting chocolate or heating delicate sauces without scorching or burning.

INVENTED MODULAR REFRIGERATION
This revolutionary system offers culinary enthusiasts flexibility and optimal food storage solutions, personalized to fit their needs.

INTRODUCED STEAM & CONVECTION OVEN
A new decade marked the introduction of Thermador Steam & Convection Ovens.

INTRODUCED STAR-SAPPHIRE™ DISHWASHER
The Star-Sapphire™ Dishwasher offers real-dish care solutions that give them the flexibility to entertain without restrictions—that complement their passion for the food experience.

CULINARY PRESERVATION CENTERS
Exclusively from Thermador, Culinary Preservation Centers offer kitchen personalization with an amazing array of Refrigerator, Freezer and Wine Column configurations.

THE ULTIMATE CULINARY CENTER GOES BIGGER
Thermador introduces the industry's only 60" Pro Grand® Range with a steam and convection combination oven plus full size convection oven, in two rangetop configurations.

INTRODUCED THE ENTERTAINER'S DISHWASHER
The new Thermador Star Sapphire® Dishwasher features everything entertainers need with unparalleled speed and capacity, including the largest wine glass capacity on the market.

1916

THERMADOR

Thermador

THERMADOR
Division of Norris Industries
5119 District Blvd. Los Angeles, California 90022

Thermador
When cooking is its own reward.

Thermador
An American Icon



Thermador★

*You Don't Design or
Build Like Anyone Else,*
NEITHER DO WE

Quality

Our commitment to quality craftsmanship dates back more than eleven decades. We are a deeply rooted American brand, with factories across the U.S. where hand-crafting products is still part of our DNA—because time-honored tradition is as important to us as it is to our consumers.

LEED Certification

Thermador appliances offer the benefits of both maximum points toward LEED® certification* and Thermador reputation and quality. Refer to the product specification pages for more detail and look for the green leaf.

Sustainability

From day one, the Thermador manufacturing plant has worked to reduce waste and our environmental footprint. The plant continuously manages to practice sustainable measures using 6-Sigma tools to reduce scrap, rework, and reuse parts produced in the process.

Commitment

With Thermador, count on a total commitment to helping build your success. We have a dedicated professional sales team and unique and rewarding trade programs. Thermador is a longtime member of NCHI and NAHB.

Trade Programs

Designed by Thermador to recognize its brand ambassadors, the Star® Partner Program features exclusive, trade-only programs. Enroll in the Thermador Star Partner Program today by visiting www.thermador.com/star-partner. Or contact your local sales representative.



STAR★PARTNER

*LEED® and related logo is a trademark owned by the U.S. Green Building Council® and is used with permission. Thermador products are not reviewed or certified under LEED. LEED credit requirements cover the performance of materials in aggregate, not the performance of individual products or brands. For more information on LEED, visit www.usgbc.org/contact



PRO GRAND® RANGES

27-INCH DEPTH

With unmatched versatility and exceptional cooking prowess, the 60-Inch Pro Grand® Range is the ideal arsenal for the avid entertainer. Simply stated, the double convection oven configuration has been designed with unequaled capacity—the largest combined oven capacity on the market. These 30-Inch and 36-Inch ovens accommodate professional grade catering trays, more casserole dishes at a given time, and bigger roasting pans. This is kitchen personalization and cooking technology designed around you.



PRO GRAND® STEAM & PRO GRAND RANGES

1.800.735.4328 | THERMADOR.COM

MODELS SHOWN: PRD606RESG PRO GRAND® RANGE AND VCIN60RP CUSTOM INSERT



Pro Grand® Ranges COMMON FEATURES

Regardless of which Thermador Pro Grand® Range you choose, you can expect your kitchen to transform into a room that is as beautiful as it is functional. Each and every Pro Grand Range features these common ingredients to create the ultimate cooking experience.



★ EXTRALOW® SIMMER

Our ExtraLow feature provides the widest variety of temperature control of any simmer system. Cycling on and off, each Star Burner® can maintain temperatures as low as 100°, a must-have option for cooks who demand perfection when preparing delicate sauces, melted cheeses, or even sugary confections. Each Thermador Pro Grand Range features four ExtraLow burners.

★ QUICKCLEAN BASE®

The raised pedestal burner and porcelain maintop have been crafted for perfect integration and easy cleanup. A hand and sponge fit easily under each burner to wipe the surface clean and a teardrop emboss reduces food buildup near the base.

★ FASTEST TIME TO BOIL

Our Star® Burner's 18,000 BTUs/hr of output and superior heat distribution boils water in a fraction of the time of a conventional range or cooktop and over 50% faster than leading competitors.

TELESCOPIC RACKS

Full Access® telescopic racks glide smoothly on ball bearings, allowing them to expand completely for safe, easy access to your meal. Plus, their robust construction safely supports the heaviest dishes while integrated easy-grip handles make them easy to use.

SINGLE FAN TECHNOLOGY

Our convection technology is so powerful that only one fan is needed. Convection keeps the temperature consistent throughout the cavity and allows for multi-rack cooking. Controlled airflow patterns optimize the transfer of heat so that food is heated evenly.

★ THERMADOR® EXCLUSIVE

★ 22K BURNER

Our powerful sealed Star® Burner delivers an industry-leading 22,000 BTUs of pure cooking power for better searing and faster boiling.

★ SOFTCLOSE® HINGES

Hydraulic SoftClose hinges prevent slamming and ensure ultra smooth closing of both ovens and the warming drawer.

EXTRA-LARGE CAPACITY OVEN

Our 36-inch and 48-inch ovens offer a maximum capacity of 5.7 cubic feet and can accommodate full-sized commercial sheet pans.

ELECTRONIC DISPLAY

Electronic oven display interfaces with cook timer, CookControl meat probe and preheat status with audible alert.

VERSATILE DESIGN OPTIONS

Pro Grand Ranges feature striking stainless steel feet or you can add a stainless steel toekick accessory for a sleek, finished look.

★ STAR-K CERTIFIED

Thermador Professional® Ranges are Star-K certified making it possible to use them on the Sabbath or the Holidays.



★ THERMADOR® EXCLUSIVE



A Star-Shaped Peg in a WORLD OF ROUND HOLES

★ OUR EXCLUSIVE, PATENTED STAR® BURNER

Lighting a heavenly fire under the status quo, the Star Burner is perhaps the single most iconic innovation from Thermador®. But the star shape isn't just for show. Featured on all Thermador Professional® Ranges, the Star Burner delivers 56% more coverage with superior flame spread and a reduced cold spot for faster and more even heating across any size pan.



Star Burner: 35 ports / 16 3/4" perimeter

Conventional Burner: 28 ports / 10 3/4" perimeter



Features Available on Selected **PRO GRAND® RANGES**

★ FASTEST SELF-CLEAN

In just 2 hours, the interior walls and rack supports become perfectly clean, thanks to the fastest self-cleaning cycle on the market.

INDOOR ELECTRIC PRO GRILL WITH CERAMIC BRIQUETTES

Our easy-to-clean, indoor grilling feature boasts industry-leading design, featuring ceramic briquettes and fusion coated grill plates that fully cover the heating elements to offer exceptional grilling performance with genuine smoky flavor while minimizing flare-ups. 2 heating zones let you control the front and back zones independently.

THIRD ELEMENT CONVECTION SYSTEM

Thermador® Dual-Fuel Ranges feature a True Convection system that directs heat to cook foods more evenly with gourmet results and 25% time savings.

12-INCH REMOVABLE GRIDDLE AND GRILL ACCESSORY

Our 12-inch non-stick, rust-proof cast-aluminum fusion coated surface griddle is thermostatically controlled to deliver consistent, even heating across the entire surface. It is also removable for easy cleaning or interchange it with our grill accessory.

Our non-stick, rust-proof cast-aluminum grill accessory (sold separately) features a fusion coated surface that is easy to clean and dishwasher-safe.

★ THERMADOR® EXCLUSIVE





The Ultimate CULINARY SERIES

Devout cooks and avid entertainers will revel in the cutting-edge innovation, personalization and exceptional versatility of our new 60-inch Ultimate Culinary Center and our new Ultimate Entertainer's Center. The 60-inch Pro Grand® Range puts the power of kitchen personalization in your hands.

How do you cook? Choose from two rangetops and two oven configurations and design the culinary center that is right for your cooking style. With this much size, power and culinary performance, the only thing larger than our 60-inch ranges is the desire to own one.

★ PERSONALIZATION IN EVERY SQUARE INCH

Thermador goes beyond expectations by offering unparalleled personalization to suit your unique cooking style. Seize the rare opportunity to mix and match two cooking surfaces and two oven configurations. Each range incorporates dual fuel rangetops with 6 Star® Burners. The rest? Is up to you! No matter what your preference, the Ultimate Culinary Series provides personal design, combined with the Thermador quality, craftsmanship and performance to power your most ambitious culinary feats.

Choose Your Rangetop Configuration

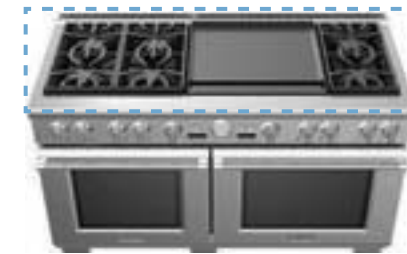

SIX BURNERS + DOUBLE GRIDDLE

It doesn't get any bigger than this. Our 24-inch Double Griddle is unrivaled for sheer size and cooking superiority. The griddle is designed with clean-up in mind and boasts a smooth, scratch resistant surface.

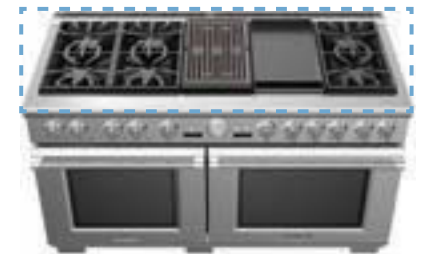

SIX BURNERS + ELECTRIC INDOOR GRILL + GRIDDLE

Unlimited cooking potential. For those wanting the flexibility to do everything, the Grill + Griddle combination is unbeatable. The 12-inch indoor grill features ceramic briquettes, authentic grilling performance and easy cleanup while the 12-inch griddle boasts a smooth, scratch resistant surface to easily handle all of your entertaining needs.

Choose Your Oven Configuration



STEAM & CONVECTION OVEN + 36-INCH CONVECTION OVEN

Healthier Results. Moisture Retention. Flavor Enhancement. The benefits of cooking with steam are plentiful. Combined with a large 36-inch convection oven that accommodates a full size sheet pan, plus a warming drawer.



TWO LARGE DOUBLE CONVECTION OVENS—30-INCH AND 36-INCH

Even Cooking. Faster Results. Improved Efficiency. Cooking with convection has been the mainstay in professional kitchens for decades. The 36-inch oven accommodates a full size sheet pan and the unequivocal secondary oven has more cu. ft. usable capacity than the competition's primary 30-inch ovens.

★ THERMADOR® EXCLUSIVE

Pro Grand® Steam Ranges

THE ULTIMATE CULINARY CENTER

It's no mere range. No mere oven. It's an arsenal for the culinary enthusiast. It's where passion for food meets our passion for innovation. Available in 48-inch and 60-inch, Thermador Pro Grand Steam Ranges are the only ranges to offer unmatched versatility and exceptional cooking prowess with seven ways to cook.



The Ultimate Culinary Center

FEATURE HIGHLIGHTS

★ THE ULTIMATE CULINARY CENTER GOES BIGGER

For those whose kitchens demand cooking superiority in a big way, Thermador offers the 60-inch Pro Grand® Steam Range. Never before has a range existed on the market at this size, with this culinary firepower. It is the only range available with a steam and convection combination oven plus full size convection oven, warming drawer and next-generation surface cooking that features a full size double griddle. With its bold and timeless design, easy-to-clean surfaces and Thermador exclusives, like our patented Star® Burner, a 60-inch Pro Grand Steam Range in the kitchen will empower you to perform your greatest culinary feats.

★ DUAL ZONE, DOUBLE GRIDDLE

Our industry leading 60-inch range boasts the largest dual zone, double griddle on the market. Zoned for perfect control for delicate foods or searing at higher temperatures. And best of all, it's very easy to clean.

★ SEVEN COOKING OPTIONS

Both the 60-inch and 48-inch Ultimate Culinary Center® feature seven distinct cooking options that will forever change the way you cook. These are the only ranges on the market to offer ExtraLow® simmering technology, 22,000 BTUs of cooking power, fusion coated surface Griddle & Grill or Double Griddle, a large capacity Convection Oven, Warming Drawer and the industry exclusive Steam & Convection Oven.

★ STEAM AND CONVECTION OVEN

The award-winning oven offers three distinct cooking variations: Steam only, Convection only or Steam & Convection Cooking which makes food crisp on the outside and moist on the inside, just like it was being served at a 5-star restaurant.

★ WARMING DRAWER

The spacious warming drawer features a state-of-the-art glass-ceramic surface that uses a powerful element to ensure quick and even heating. It's easy-to-clean and you can place food directly on the surface. An integrated warming drawer is the ultimate indulgence for the culinary enthusiast.

★ THERMADOR® EXCLUSIVE



60-Inch Pro Grand® Ranges

THE ULTIMATE ENTERTAINER'S CENTER

With unmatched versatility and exceptional cooking prowess, The Ultimate Entertainer's Center is the ideal arsenal for culinary enthusiasts who love to entertain and want the powerful possibilities to ensure exceptional results.



60-Inch Ultimate Entertainer's Center

FEATURE HIGHLIGHTS

★ THE BIG STORY—30+36=60

How does 30+36=60? Simply stated, our ovens have been re-designed to perform for the ultimate entertainer. The 36-inch convection oven accommodates professional-grade catering trays and the secondary oven has more cu. ft. usable capacity than the competition's primary 30-inch ovens. At a massive 10.6 cubic square feet, it has the largest combined oven cooking capacity on the market.

★ DUAL ZONE, DOUBLE GRIDDLE

The 60-inch Ultimate Entertainer's Center is available with the largest dual zone, double griddle on the market. Zoned for perfect control for delicate foods or searing at higher temperatures. And best of all, it's very easy to clean.

★ FLUSH WALL INSTALL

By incorporating innovative venting technology that reduces back wall temperatures, the 60-inch Pro Grand® Range is the first of its size that can be installed flush against a combustible wall with zero clearance for pure, unadulterated design flexibility.









★ THERMADOR® EXCLUSIVE

PRO GRAND® RANGES
OPTIONAL ACCESSORIES

	36-INCH DUAL-FUEL			36-INCH GAS					
	PRD364JDGU	PRD364NLGU	PRD366JGU	PRG364JDG	PRL364JDG	PRG364NLG	PRL364NLG	PRG366JG	PRL366JG
 PABRICKBKN Black Ceramic Briquettes with Basket		✓				✓	✓		
 PA12GRILLN 12" Pro Grill	✓			✓	✓				
 PA12LCVRN 12" Pro Grill Cover for Indoor Electric Grill		✓				✓	✓		
 PA12CVRJ 12" Pro Grill / Griddle Cover	✓			✓	✓				
 PA36JLBG 9" Low Backguard	✓	✓	✓	✓	✓	✓	✓	✓	✓
 PAGRIDDLN Griddle for Indoor Electric Grill		✓				✓	✓		
 PA12CHPBLK 12" Cutting Board	✓	✓	✓	✓	✓	✓	✓	✓	✓
 PA36JTKG Toekick	✓	✓	✓	✓	✓	✓	✓	✓	✓
 PAGRIDDLN Griddle	✓	✓	✓	✓	✓	✓	✓	✓	✓
 PWOKRINGHC Wok Ring	✓	✓	✓	✓	✓	✓	✓	✓	✓
 PAKNOBLUNG Blue Knob Pro Grand Kit	✓	✓	✓	✓	✓	✓	✓	✓	✓



PRO GRAND® RANGES
OPTIONAL ACCESSORIES

	48-INCH DUAL-FUEL						48-INCH GAS			
	PRD48JDSGU	PRD48NLSGU	PRD48NCSGU	PRD486JDGU	PRD486NLGU	PRD484NCGU	PRG486JDG	PRL486JDG	PRG486NLG	PRL486NLG
 PABRICKBKN Black Ceramic Briquettes with Basket		✓	✓		✓	✓			✓	✓
 PA12GRILLN 12" Pro Grill	✓			✓			✓	✓		
 PA12LCVRN 12" Pro Grill Cover for Indoor Electric Grill		✓	✓		✓	✓			✓	✓
 PA12CVRJ 12" Pro Grill / Griddle Cover	✓			✓			✓	✓		
 PA48JLBSG 9" Low Backguard	✓	✓	✓							
 PA48JLBG 9" Low Backguard				✓	✓	✓	✓	✓	✓	✓
 PAGRIDDLN Griddle for Indoor Electric Grill		✓	✓		✓	✓			✓	✓
 PA12CHPBLK 12" Cutting Board	✓	✓	✓	✓	✓	✓	✓	✓	✓	✓
 PA48JTKG Toekick	✓	✓	✓	✓	✓	✓	✓	✓	✓	✓
 PAGRIDDLN Griddle	✓	✓	✓	✓	✓	✓	✓	✓	✓	✓
 PWOKRINGHC Wok Ring	✓	✓	✓	✓	✓	✓	✓	✓	✓	✓
 PA48JTKG Toekick	✓	✓	✓	✓	✓	✓	✓	✓	✓	✓
 PAKNOBLUNG Blue Knob Pro Grand Kit	✓	✓	✓	✓	✓	✓	✓	✓	✓	✓
 CSRACKH Wire Rack	✓	✓	✓							
 CS2XLH Cooking Pan – Full Size	✓	✓	✓							
 CS1XLPH Perforated Cooking Pan – Half Size (1 5/8" Deep)	✓	✓	✓							
 CS1XLH Cooking Pan – Half Size	✓	✓	✓							
 CS2XLPH Perforated Cooking Pan – Full Size (1 5/8" Deep)	✓	✓	✓							
 CS2LH Baking Tray	✓	✓	✓							

PRO GRAND® RANGES
OPTIONAL ACCESSORIES

		60-INCH DUAL-FUEL			
		PRD606RCG	PRD606REG	PRD606RCSG	PRD606RESG
	PABRICKBKN Black Ceramic Briquettes with Basket	✓		✓	
	PA12GRILLN 12" Pro Grill	✓		✓	
	PA12LCVRN 12" Pro Grill Cover for Indoor Electric Grill	✓		✓	
	PA12CVRJ 12" Pro Grill / Griddle Cover	✓		✓	
	PA24CVRR 24" Griddle Cover		✓		✓
	PA60RLBG 9" Low Backguard	✓	✓	✓	✓
	PAGRIDDLEN Griddle for Indoor Electric Grill	✓		✓	
	PA12CHPBLK 12" Cutting Board	✓	✓	✓	✓
	PAGRIDDLE Griddle	✓	✓	✓	✓
	PAWOKRINGHC Wok Ring	✓	✓	✓	✓
	PA60RTKG Toekick	✓	✓	✓	✓
	PAKNOBLURG Blue Knob Pro Grand Kit	✓	✓	✓	✓
	CSRACKH Wire Rack			✓	✓
	CS2XLH Cooking Pan - Full Size			✓	✓
	CS1XLPH Perforated Cooking Pan - Half Size (1 5/8" Deep)			✓	✓
	CS1XLH Cooking Pan - Half Size			✓	✓
	CS2XLPH Perforated Cooking Pan - Full Size (1 5/8" Deep)			✓	✓
	CS2LH Baking Tray			✓	✓

PRD366JGU
36-INCH DUAL-FUEL PRO GRAND® RANGE
PROFESSIONAL SERIES, COMMERCIAL-DEPTH, PORCELAIN COOKTOP SURFACE



FEATURES & BENEFITS

- ★ - Patented Pedestal Star® Burner with QuickClean Base® designed for easy surface cleaning and superior heat spread for any size pan
- ★ - Powerful 22,000 BTU (NG) burner (front right)
- ★ - Precision simmering capabilities as low as 100°F (375 BTU) with 4 ExtraLow® Simmer burners
- ★ - SoftClose® hinges for ultra smooth closing of the oven door
- ★ - Superfast 2-hour self-clean mode—fastest in the industry

TECHNICAL DETAILS

Circuit Breaker (A)	40 A
Volts (V)	240 / 208 V
Frequency (Hz)	60 Hz
Plug Type	No Plug
Power Cord Length (in)	Purchase Separately
Energy Source	Gas and Electric
Gas Type	Natural Gas 15 mbar (USA)
Alternative Gas Type	Liquid Gas 27.5 mbar (USA)

GENERAL PROPERTIES

Oven Capacity	5.7 cu. ft.
Cooking Modes - Main / Large Cavity	
Bake, Convection Bake, Broil, Convection Broil, Roast, Convection Roast, Self Clean, Keep Warm	
Cooking Modes - Small Cavity	N/A
Additional Features	
Meat Probe, Sabbath Function, Cook Timer, Kitchen Timer	
Cleaning Type	Self Clean
Type of Grate	Continuous Cast Iron
Controls	Metal Knobs and LCD Display
Warming Drawer	No
Sealed Burners	Yes

OVEN PERFORMANCE

Bake Power	2,000 W
Broil Power	4,000 W
Convection Power	2,750 W

BURNER PERFORMANCE

Total Number of Cooktop Burners	6
Power of Front Left Burner BTU	18,000 and XLO (NG)
Power of Back Left Burner BTU	18,000 and XLO (NG)
Power of Back Center Burner BTU	18,000 (NG)
Power of Front Center Burner BTU	18,000 (NG)
Power of Center 12" Electric Griddle (W)	N/A
Power of Center 12" Electric Grill (W)	N/A
Power of Far Right 12" Electric Griddle (W)	N/A
Power of Back Right Burner BTU	18,000 and XLO (NG)
Power of Front Right Burner BTU	22,000 and XLO (NG)

DIMENSIONS & WEIGHT

Overall Appliance Dimensions (HxWxD) (in)	35 7/8"-36 3/4" x 35 15/16" x 28 3/4"
Required Cutout Size (HxWxD) (in)	35 7/8"-36 3/4" x 36" x 24"-25 1/8"
Adjustable Range Height (in.)	7/8"
Net Weight (lbs)	360 lbs

ACCESSORIES (INCLUDED)

1 X Nozzle Set for Liquid Gas, 3 X Telescopic Rack, 1 X Temperature Sensor, 1 X Island Trim, 1 X Broiler Pan

WARRANTY

Limited Warranty, Entire Appliance, Parts and Labor	2 Year
---	--------

PRD364JDGU

36-INCH DUAL-FUEL PRO GRAND® RANGE WITH GRIDDLE

PROFESSIONAL SERIES, COMMERCIAL-DEPTH, PORCELAIN COOKTOP SURFACE



FEATURES & BENEFITS

- ★ - Patented Pedestal Star® Burner with QuickClean Base® designed for easy surface cleaning and superior heat spread for any size pan
- ★ - Powerful 22,000 BTU (NG) burner (front right)
- ★ - Precision simmering capabilities as low as 100°F (375 BTU) with 4 ExtraLow® Simmer burners
- ★ - SoftClose® hinges for ultra smooth closing of the oven door
- ★ - Superfast 2-hour self-clean mode—fastest in the industry

TECHNICAL DETAILS

Circuit Breaker (A)	40 A
Volts (V)	240 / 208 V
Frequency (Hz)	60 Hz
Plug Type	No Plug
Power Cord Length (in)	Purchase Separately
Energy Source	Gas and Electric
Gas Type	Natural Gas 15 mbar (USA)
Alternative Gas Type	Liquid Gas 27.5 mbar (USA)

GENERAL PROPERTIES

Oven Capacity	5.7 cu. ft.
Cooking Modes - Main / Large Cavity	
Bake, Convection Bake, Broil, Convection Broil, Roast, Convection Roast, Self Clean, Keep Warm	
Cooking Modes - Small Cavity	N/A
Additional Features	
Meat Probe, Sabbath Function, Cook Timer, Kitchen Timer	
Cleaning Type	Self Clean
Type of Grate	Continuous Cast Iron
Controls	Metal Knobs and LCD Display
Warming Drawer	No
Sealed Burners	Yes

OVEN PERFORMANCE

Bake Power	2,000 W
Broil Power	4,000 W
Convection Power	2,750 W

BURNER PERFORMANCE

Total Number of Cooktop Burners	4 + Griddle
Power of Front Left Burner BTU	18,000 and XLO (NG)
Power of Back Left Burner BTU	18,000 and XLO (NG)
Power of Back Center Burner BTU	N/A
Power of Front Center Burner BTU	N/A
Power of Center 12" Electric Griddle (W)	1,630 W
Power of Center 12" Electric Grill (W)	N/A
Power of Far Right 12" Electric Griddle (W)	N/A
Power of Back Right Burner BTU	18,000 and XLO (NG)
Power of Front Right Burner BTU	22,000 and XLO (NG)

DIMENSIONS & WEIGHT

Overall Appliance Dimensions (HxWxD) (in)	35 7/8"–36 3/4" x 35 15/16" x 28 3/4"
Required Cutout Size (HxWxD) (in)	35 7/8"–36 3/4" x 36" x 24"–25 1/8"
Adjustable Range Height (in.)	7/8"
Net Weight (lbs)	360 lbs

ACCESSORIES (INCLUDED)

1 X Nozzle Set for Liquid Gas, 3 X Telescopic Rack, 1 X Temperature Sensor, 1 X Island Trim, 1 X Grill Plate, 1 X Broiler Pan

WARRANTY

Limited Warranty, Entire Appliance, Parts and Labor	2 Year
---	--------

PRD364NLGU

36-INCH DUAL-FUEL PRO GRAND® RANGE WITH GRILL

PROFESSIONAL SERIES, COMMERCIAL-DEPTH, PORCELAIN COOKTOP SURFACE



FEATURES & BENEFITS

- ★ - Patented Pedestal Star® Burner with QuickClean Base® designed for easy surface cleaning and superior heat spread for any size pan
- ★ - Powerful 22,000 BTU (NG) burner (front right)
- ★ - Precision simmering capabilities as low as 100°F (375 BTU) with 4 ExtraLow® Simmer burners
- ★ - SoftClose® hinges for ultra smooth closing of the oven door
- ★ - Superfast 2-hour self-clean mode—fastest in the industry

TECHNICAL DETAILS

Circuit Breaker (A)	40 A
Volts (V)	240 / 208 V
Frequency (Hz)	60 Hz
Plug Type	No Plug
Power Cord Length (in)	Purchase Separately
Energy Source	Gas and Electric
Gas Type	Natural Gas 15 mbar (USA)
Alternative Gas Type	Liquid Gas 27.5 mbar (USA)

GENERAL PROPERTIES

Oven Capacity	5.7 cu. ft.
Cooking Modes - Main / Large Cavity	
Bake, Convection Bake, Broil, Convection Broil, Roast, Convection Roast, Self Clean, Keep Warm	
Cooking Modes - Small Cavity	N/A
Additional Features	
Meat Probe, Sabbath Function, Cook Timer, Kitchen Timer	
Cleaning Type	Self Clean
Type of Grate	Continuous Cast Iron
Controls	Metal Knobs and LCD Display
Warming Drawer	No
Sealed Burners	Yes

OVEN PERFORMANCE

Bake Power	2,000 W
Broil Power	4,000 W
Convection Power	2,750 W

BURNER PERFORMANCE

Total Number of Cooktop Burners	4 + Grill
Power of Front Left Burner BTU	18,000 and XLO (NG)
Power of Back Left Burner BTU	18,000 and XLO (NG)
Power of Back Center Burner BTU	N/A
Power of Front Center Burner BTU	N/A
Power of Center 12" Electric Griddle (W)	N/A
Power of Center 12" Electric Grill (W)	2,000 W
Power of Far Right 12" Electric Griddle (W)	N/A
Power of Back Right Burner BTU	18,000 and XLO (NG)
Power of Front Right Burner BTU	22,000 and XLO (NG)

DIMENSIONS & WEIGHT

Overall Appliance Dimensions (HxWxD) (in)	35 7/8"–36 3/4" x 35 15/16" x 28 3/4"
Required Cutout Size (HxWxD) (in)	35 7/8"–36 3/4" x 36" x 24"–25 1/8"
Adjustable Range Height (in.)	7/8"
Net Weight (lbs)	360 lbs

ACCESSORIES (INCLUDED)

1 X Nozzle Set for Liquid Gas, 3 X Telescopic Rack, 1 X Temperature Sensor, 1 X Island Trim, 1 X Grill Plate, 1 X Broiler Pan

WARRANTY

Limited Warranty, Entire Appliance, Parts and Labor	2 Year
---	--------

PRG366JG
36-INCH GAS PRO GRAND® RANGE
 PROFESSIONAL SERIES, COMMERCIAL-DEPTH, PORCELAIN COOKTOP SURFACE



Also Available:
 PRL366JG - LP

FEATURES & BENEFITS

- ★ - Patented Pedestal Star® Burner with QuickClean Base® designed for easy surface cleaning and superior heat spread for any size pan
- ★ - Powerful 22,000 BTU (NG) burner (front right)
- ★ - Precision simmering capabilities as low as 100°F (375 BTU) with 4 ExtraLow® Simmer burners
- ★ - SoftClose® hinges for ultra smooth closing of the oven door
- ★ - Superfast 2-hour self-clean mode—fastest in the industry

TECHNICAL DETAILS

Circuit Breaker (A)	15 A
Volts (V)	120 V
Frequency (Hz)	60 Hz; 50-60 Hz
Plug Type	120V-3 Prong
Power Cord Length (in)	96"
Energy Source	Gas
Gas Type	Natural Gas 15 mbar (USA)
Alternative Gas Type	Liquid Gas 27.5 mbar (USA)

GENERAL PROPERTIES

Oven Capacity	5.5 cu. ft.
Cooking Modes - Main / Large Cavity	
Bake, Convection Bake, Broil, Roast, Self Clean, Keep Warm	
Cooking Modes - Small Cavity	N/A
Additional Features	
Meat Probe, Sabbath Function, Cook Timer, Kitchen Timer	
Cleaning Type	Self Clean
Type of Grate	Continuous Cast Iron
Controls	Metal Knobs and LCD Display
Warming Drawer	No
Sealed Burners	Yes

OVEN PERFORMANCE

Bake Power	30,000 BTU (NG)
Broil Power	17,000 BTU (NG)
Convection Power	N/A

BURNER PERFORMANCE

Total Number of Cooktop Burners	6
Power of Front Left Burner BTU	18,000 and XLO (NG)
Power of Back Left Burner BTU	18,000 and XLO (NG)
Power of Back Center Burner BTU	18,000 (NG)
Power of Front Center Burner BTU	18,000 (NG)
Power of Center 12" Electric Griddle (W)	N/A
Power of Center 12" Electric Grill (W)	N/A
Power of Far Right 12" Electric Griddle (W)	N/A
Power of Back Right Burner BTU	18,000 and XLO (NG)
Power of Front Right Burner BTU	22,000 and XLO (NG)

DIMENSIONS & WEIGHT

Overall Appliance Dimensions (HxWxD) (in)	35 7/8"-36 3/4" x 35 15/16" x 28 3/4"
Required Cutout Size (HxWxD) (in)	35 7/8"-36 3/4" x 36" x 24"-25 1/8"
Adjustable Range Height (in.)	7/8"
Net Weight (lbs)	360 lbs

ACCESSORIES (INCLUDED)

3 X Telescopic Rack, 1 X Temperature Sensor, 1 X Island Trim, 1 X Broiler Pan

WARRANTY

Limited Warranty, Entire Appliance, Parts and Labor	2 Year
---	--------

See page 24 for optional accessories.

PRL366JG
36-INCH GAS PRO GRAND® RANGE (LP)
 PROFESSIONAL SERIES, COMMERCIAL-DEPTH, PORCELAIN COOKTOP SURFACE



Also Available:
 PRG366JG - Natural Gas

FEATURES & BENEFITS

- ★ - Patented Pedestal Star® Burner with QuickClean Base® designed for easy surface cleaning and superior heat spread for any size pan
- ★ - Powerful 18,000 BTU (LP) burner (front right)
- ★ - Precision simmering capabilities as low as 100°F (375 BTU) with 4 ExtraLow® Simmer burners
- ★ - SoftClose® hinges for ultra smooth closing of the oven door
- ★ - Superfast 2-hour self-clean mode—fastest in the industry

TECHNICAL DETAILS

Circuit Breaker (A)	15 A
Volts (V)	120 V
Frequency (Hz)	60 Hz
Plug Type	120V-3 Prong
Power Cord Length (in)	96"
Energy Source	Gas
Gas Type	Liquid Gas 27, 5 mbar (USA)
Alternative Gas Type	Liquid Gas 27.5 mbar (USA)

GENERAL PROPERTIES

Oven Capacity	5.5 cu. ft.
Cooking Modes - Main / Large Cavity	
Bake, Convection Bake, Broil, Roast, Self Clean, Keep Warm	
Cooking Modes - Small Cavity	N/A
Additional Features	
Meat Probe, Sabbath Function, Cook Timer, Kitchen Timer	
Cleaning Type	Self Clean
Type of Grate	Continuous Cast Iron
Controls	Metal Knobs and LCD Display
Warming Drawer	No
Sealed Burners	Yes

OVEN PERFORMANCE

Bake Power	25,000 BTU (LP)
Broil Power	17,000 BTU (LP)
Convection Power	N/A

BURNER PERFORMANCE

Total Number of Cooktop Burners	6
Power of Front Left Burner BTU	15,000 and XLO (LP)
Power of Back Left Burner BTU	15,000 and XLO (LP)
Power of Back Center Burner BTU	15,000 (LP)
Power of Front Center Burner BTU	15,000 (LP)
Power of Center 12" Electric Griddle (W)	N/A
Power of Center 12" Electric Grill (W)	N/A
Power of Far Right 12" Electric Griddle (W)	N/A
Power of Back Right Burner BTU	15,000 and XLO (LP)
Power of Front Right Burner BTU	18,000 and XLO (LP)

DIMENSIONS & WEIGHT

Overall Appliance Dimensions (HxWxD) (in)	35 7/8"-36 3/4" x 35 15/16" x 28 3/4"
Required Cutout Size (HxWxD) (in)	35 7/8"-36 3/4" x 36" x 24"-25 1/8"
Adjustable Range Height (in.)	7/8"
Net Weight (lbs)	360 lbs

ACCESSORIES (INCLUDED)

3 X Telescopic Rack, 1 X Temperature Sensor, 1 X Island Trim, 1 X Broiler Pan

WARRANTY

Limited Warranty, Entire Appliance, Parts and Labor	2 Year
---	--------

See page 24 for optional accessories.

PRG364JDG
36-INCH GAS PRO GRAND® RANGE WITH GRIDDLE
 PROFESSIONAL SERIES, COMMERCIAL-DEPTH, PORCELAIN COOKTOP SURFACE



GENERAL PROPERTIES	
Oven Capacity	5.5 cu. ft.
Cooking Modes - Main / Large Cavity	
Bake, Convection Bake, Broil, Roast, Self Clean, Keep Warm	
Cooking Modes - Small Cavity	N/A
Additional Features	
Meat Probe, Sabbath Function, Cook Timer, Kitchen Timer	
Cleaning Type	Self Clean
Type of Grate	Continuous Cast Iron
Controls	Metal Knobs and LCD Display
Warming Drawer	No
Sealed Burners	Yes

OVEN PERFORMANCE	
Bake Power	30,000 BTU (NG)
Broil Power	17,000 BTU (NG)
Convection Power	N/A

BURNER PERFORMANCE	
Total Number of Cooktop Burners	4 + Griddle
Power of Front Left Burner BTU	18,000 and XLO (NG)
Power of Back Left Burner BTU	18,000 and XLO (NG)
Power of Back Center Burner BTU	N/A
Power of Front Center Burner BTU	N/A
Power of Center 12" Electric Griddle (W)	1,630 W
Power of Center 12" Electric Grill (W)	N/A
Power of Far Right 12" Electric Griddle (W)	N/A
Power of Back Right Burner BTU	18,000 and XLO (NG)
Power of Front Right Burner BTU	22,000 and XLO (NG)

DIMENSIONS & WEIGHT	
Overall Appliance Dimensions (HxWxD) (in)	35 7/8"-36 3/4" x 35 15/16" x 28 3/4"
Required Cutout Size (HxWxD) (in)	35 7/8"-36 3/4" x 36" x 24"-25 1/8"
Adjustable Range Height (in.)	7/8"
Net Weight (lbs)	360 lbs

ACCESSORIES (INCLUDED)	
3 X Telescopic Rack, 1 X Temperature Sensor, 1 X Island Trim, 1 X Grill Plate, 1 X Broiler Pan	

WARRANTY	
Limited Warranty, Entire Appliance, Parts and Labor	2 Year

Also Available:
 PRL364JDG - LP

FEATURES & BENEFITS

- ★ - Patented Pedestal Star® Burner with QuickClean Base® designed for easy surface cleaning and superior heat spread for any size pan
- ★ - Powerful 22,000 BTU (NG) burner (front right)
- ★ - Precision simmering capabilities as low as 100°F (375 BTU) with 4 ExtraLow® Simmer burners
- ★ - SoftClose® hinges for ultra smooth closing of the oven door
- ★ - Superfast 2-hour self-clean mode—fastest in the industry

TECHNICAL DETAILS

Circuit Breaker (A)	20 A
Volts (V)	120 V
Frequency (Hz)	60 Hz
Plug Type	120V-3 Prong NEMA 5-20
Power Cord Length (in)	96"
Energy Source	Gas
Gas Type	Natural Gas 15 mbar (USA)
Alternative Gas Type	Liquid Gas 27.5 mbar (USA)

See page 24 for optional accessories.

PRG364NLG
36-INCH GAS PRO GRAND® RANGE WITH GRILL
 PROFESSIONAL SERIES, COMMERCIAL-DEPTH, PORCELAIN COOKTOP SURFACE



GENERAL PROPERTIES	
Oven Capacity	5.5 cu. ft.
Cooking Modes - Main / Large Cavity	
Bake, Convection Bake, Broil, Roast, Self Clean, Keep Warm	
Cooking Modes - Small Cavity	N/A
Additional Features	
Meat Probe, Sabbath Function, Cook Timer, Kitchen Timer	
Cleaning Type	Self Clean
Type of Grate	Continuous Cast Iron
Controls	Metal Knobs and LCD Display
Warming Drawer	No
Sealed Burners	Yes

OVEN PERFORMANCE	
Bake Power	30,000 BTU (NG)
Broil Power	17,000 BTU (NG)
Convection Power	N/A

BURNER PERFORMANCE	
Total Number of Cooktop Burners	4 + Grill
Power of Front Left Burner BTU	18,000 and XLO (NG)
Power of Back Left Burner BTU	18,000 and XLO (NG)
Power of Back Center Burner BTU	N/A
Power of Front Center Burner BTU	N/A
Power of Center 12" Electric Griddle (W)	N/A
Power of Center 12" Electric Grill (W)	1,630 W
Power of Far Right 12" Electric Griddle (W)	N/A
Power of Back Right Burner BTU	18,000 and XLO (NG)
Power of Front Right Burner BTU	22,000 and XLO (NG)

DIMENSIONS & WEIGHT	
Overall Appliance Dimensions (HxWxD) (in)	35 7/8"-36 3/4" x 35 15/16" x 28 3/4"
Required Cutout Size (HxWxD) (in)	35 7/8"-36 3/4" x 36" x 24"-25 1/8"
Adjustable Range Height (in.)	7/8"
Net Weight (lbs)	360 lbs

ACCESSORIES (INCLUDED)	
3 X Telescopic Rack, 1 X Temperature Sensor, 1 X Island Trim, 1 X Grill Plate, 1 X Broiler Pan	

WARRANTY	
Limited Warranty, Entire Appliance, Parts and Labor	2 Year

Also Available:
 PRL364NLG - LP

FEATURES & BENEFITS

- ★ - Patented Pedestal Star® Burner with QuickClean Base® designed for easy surface cleaning and superior heat spread for any size pan
- ★ - Powerful 22,000 BTU (NG) burner (front right)
- ★ - Precision simmering capabilities as low as 100°F (375 BTU) with 4 ExtraLow® Simmer burners
- ★ - SoftClose® hinges for ultra smooth closing of the oven door
- ★ - Superfast 2-hour self-clean mode—fastest in the industry

TECHNICAL DETAILS

Circuit Breaker (A)	20 A
Volts (V)	120 V
Frequency (Hz)	60 Hz
Plug Type	120V-3 Prong
Power Cord Length (in)	96"
Energy Source	Gas
Gas Type	Natural Gas 15 mbar (USA)
Alternative Gas Type	Liquid Gas 27.5 mbar (USA)

See page 24 for optional accessories.

PRL364JDG

36-INCH GAS PRO GRAND® RANGE WITH GRIDDLE (LP)

PROFESSIONAL SERIES, COMMERCIAL-DEPTH, PORCELAIN COOKTOP SURFACE



GENERAL PROPERTIES	
Oven Capacity	5.5 cu. ft.
Cooking Modes - Main / Large Cavity	
Bake, Convection Bake, Broil, Roast, Self Clean, Keep Warm	
Cooking Modes - Small Cavity	N/A
Additional Features	
Meat Probe, Sabbath Function, Cook Timer, Kitchen Timer	
Cleaning Type	Self Clean
Type of Grate	Continuous Cast Iron
Controls	Metal Knobs and LCD Display
Warming Drawer	No
Sealed Burners	Yes

OVEN PERFORMANCE	
Bake Power	25,000 BTU (LP)
Broil Power	17,000 BTU (LP)
Convection Power	N/A

BURNER PERFORMANCE	
Total Number of Cooktop Burners	4 + Griddle
Power of Front Left Burner BTU	15,000 and XLO (LP)
Power of Back Left Burner BTU	15,000 and XLO (LP)
Power of Back Center Burner BTU	N/A
Power of Front Center Burner BTU	N/A
Power of Center 12" Electric Griddle (W)	1,630 W
Power of Center 12" Electric Grill (W)	N/A
Power of Far Right 12" Electric Griddle (W)	N/A
Power of Back Right Burner BTU	15,000 and XLO (LP)
Power of Front Right Burner BTU	18,000 and XLO (LP)

DIMENSIONS & WEIGHT	
Overall Appliance Dimensions (HxWxD) (in)	35 7/8"-36 3/4" x 35 15/16" x 28 3/4"
Required Cutout Size (HxWxD) (in)	35 7/8"-36 3/4" x 36" x 24"-25 1/8"
Adjustable Range Height (in.)	7/8"
Net Weight (lbs)	360 lbs

ACCESSORIES (INCLUDED)	
3 X Telescopic Rack, 1 X Temperature Sensor, 1 X Island Trim, 1 X Grill Plate, 1 X Broiler Pan	

WARRANTY	
Limited Warranty, Entire Appliance, Parts and Labor	2 Year

Also Available:
PRG364JDG - Natural Gas

FEATURES & BENEFITS

- ★ - Patented Pedestal Star® Burner with QuickClean Base® designed for easy surface cleaning and superior heat spread for any size pan
- ★ - Powerful 18,000 BTU (LP) burner (front right)
- ★ - Precision simmering capabilities as low as 100°F (375 BTU) with 4 ExtraLow® Simmer burners
- ★ - SoftClose® hinges for ultra smooth closing of the oven door
- ★ - Superfast 2-hour self-clean mode—fastest in the industry

TECHNICAL DETAILS

Circuit Breaker (A)	20 A
Volts (V)	120 V
Frequency (Hz)	60 Hz
Plug Type	120V-3 Prong NEMA 5-20
Power Cord Length (in)	96"
Energy Source	Gas
Gas Type	Liquid Gas 27.5 mbar (USA)
Alternative Gas Type	Natural Gas 15 mbar (USA)

See page 24 for optional accessories.

PRL364NLG

36-INCH GAS PRO GRAND® RANGE WITH GRILL (LP)

PROFESSIONAL SERIES, COMMERCIAL-DEPTH, PORCELAIN COOKTOP SURFACE



GENERAL PROPERTIES	
Oven Capacity	5.5 cu. ft.
Cooking Modes - Main / Large Cavity	
Bake, Convection Bake, Broil, Roast, Self Clean, Keep Warm	
Cooking Modes - Small Cavity	N/A
Additional Features	
Meat Probe, Sabbath Function, Cook Timer, Kitchen Timer	
Cleaning Type	Self Clean
Type of Grate	Continuous Cast Iron
Controls	Metal Knobs and LCD Display
Warming Drawer	No
Sealed Burners	Yes

OVEN PERFORMANCE	
Bake Power	25,000 BTU (LP)
Broil Power	17,000 BTU (LP)
Convection Power	N/A

BURNER PERFORMANCE	
Total Number of Cooktop Burners	4 + Grill
Power of Front Left Burner BTU	15,000 and XLO (LP)
Power of Back Left Burner BTU	15,000 and XLO (LP)
Power of Back Center Burner BTU	N/A
Power of Front Center Burner BTU	N/A
Power of Center 12" Electric Griddle (W)	N/A
Power of Center 12" Electric Grill (W)	1,630 W
Power of Far Right 12" Electric Griddle (W)	N/A
Power of Back Right Burner BTU	15,000 and XLO (LP)
Power of Front Right Burner BTU	18,000 and XLO (LP)

DIMENSIONS & WEIGHT	
Overall Appliance Dimensions (HxWxD) (in)	35 7/8"-36 3/4" x 35 15/16" x 28 3/4"
Required Cutout Size (HxWxD) (in)	35 7/8"-36 3/4" x 36" x 24"-25 1/8"
Adjustable Range Height (in.)	7/8"
Net Weight (lbs)	360 lbs

ACCESSORIES (INCLUDED)	
3 X Telescopic Rack, 1 X Temperature Sensor, 1 X Island Trim, 1 X Grill Plate, 1 X Broiler Pan	

WARRANTY	
Limited Warranty, Entire Appliance, Parts and Labor	2 Year

Also Available:
PRG364NLG - Natural Gas

FEATURES & BENEFITS

- ★ - Patented Pedestal Star® Burner with QuickClean Base® designed for easy surface cleaning and superior heat spread for any size pan
- ★ - Powerful 18,000 BTU (LP) burner (front right)
- ★ - Precision simmering capabilities as low as 100°F (375 BTU) with 4 ExtraLow® Simmer burners
- ★ - SoftClose® hinges for ultra smooth closing of the oven door
- ★ - Superfast 2-hour self-clean mode—fastest in the industry

TECHNICAL DETAILS

Circuit Breaker (A)	20 A
Volts (V)	120 V
Frequency (Hz)	60 Hz
Plug Type	120V-3 Prong
Power Cord Length (in)	96"
Energy Source	Gas
Gas Type	Liquid Gas 27.5 mbar (USA)
Alternative Gas Type	Natural Gas 15 mbar (USA)

See page 24 for optional accessories.

PRD486JDGU

48-INCH DUAL-FUEL PRO GRAND® RANGE WITH GRIDDLE

PROFESSIONAL SERIES, COMMERCIAL-DEPTH, PORCELAIN COOKTOP SURFACE



GENERAL PROPERTIES

Oven Capacity	5.7 / 2.5 cu. ft.
Cooking Modes - Main / Large Cavity	Bake, Convection Bake, Broil, Convection Broil, Roast, Convection Roast, Self Clean, Keep Warm
Cooking Modes - Small Cavity	Bake, Convection Bake, Broil, Convection Broil, Roast, Convection Roast, Self Clean, Proof
Additional Features	Meat Probe, Sabbath Function, Cook Timer, Kitchen Timer
Cleaning Type	Self Clean (Both)
Type of Grate	Continuous Cast Iron
Controls	Metal Knobs and LCD Display
Warming Drawer	No
Sealed Burners	Yes

OVEN PERFORMANCE

Bake Power	2,000 W (Lg) / 1,400 W (Sm)
Broil Power	4,000 W (Lg) / 3,600 W (Sm)
Convection Power	2,750 W (Lg) / 1,960 W (Sm)

BURNER PERFORMANCE

Total Number of Cooktop Burners	6 + Griddle
Power of Front Left Burner BTU	18,000 and XLO (NG)
Power of Back Left Burner BTU	18,000 and XLO (NG)
Power of Back Center Burner BTU	18,000 (NG)
Power of Front Center Burner BTU	18,000 (NG)
Power of Center 12" Electric Griddle (W)	1,630 W
Power of Center 12" Electric Grill (W)	N/A
Power of Far Right 12" Electric Griddle (W)	N/A
Power of Back Right Burner BTU	18,000 and XLO (NG)
Power of Front Right Burner BTU	22,000 and XLO (NG)

DIMENSIONS & WEIGHT

Overall Appliance Dimensions (HxWxD) (in)	35 7/8"–36 3/4" x 47 15/16" x 28 3/4"
Required Cutout Size (HxWxD) (in)	35 7/8"–36 3/4" x 48" x 24"–25 1/8"
Adjustable Range Height (in.)	7/8"
Net Weight (lbs)	530 lbs

WARRANTY

Limited Warranty, Entire Appliance, Parts and Labor	2 Year
---	--------

FEATURES & BENEFITS

- ★ - Patented Pedestal Star® Burner with QuickClean Base® designed for easy surface cleaning and superior heat spread for any size pan
- ★ - Powerful 22,000 BTU (NG) burner (front right)
- ★ - Precision simmering capabilities as low as 100°F (375 BTU) with 4 ExtraLow® Simmer burners
- ★ - SoftClose® hinges for ultra smooth closing of the oven door
- ★ - Cleans both ovens simultaneously in just 2 hours

TECHNICAL DETAILS

Circuit Breaker (A)	50 A
Volts (V)	240 / 208 V
Frequency (Hz)	60 Hz
Plug Type	No Plug
Power Cord Length (in)	Purchase Separately
Energy Source	Gas and Electric
Gas Type	Natural Gas 15 mbar (USA)
Alternative Gas Type	Liquid Gas 27.5 mbar (USA)

See page 25 for optional accessories.

PRD486NLGU

48-INCH DUAL-FUEL PRO GRAND® RANGE WITH GRILL

PROFESSIONAL SERIES, COMMERCIAL-DEPTH, PORCELAIN COOKTOP SURFACE



GENERAL PROPERTIES

Oven Capacity	5.7 / 2.5 cu. ft.
Cooking Modes - Main / Large Cavity	Bake, Convection Bake, Broil, Convection Broil, Roast, Convection Roast, Self Clean, Keep Warm
Cooking Modes - Small Cavity	Bake, Convection Bake, Broil, Convection Broil, Roast, Convection Roast, Self Clean, Proof
Additional Features	Meat Probe, Sabbath Function, Cook Timer, Kitchen Timer
Cleaning Type	Self Clean (Both)
Type of Grate	Continuous Cast Iron
Controls	Metal Knobs and LCD Display
Warming Drawer	No
Sealed Burners	Yes

OVEN PERFORMANCE

Bake Power	2,000 W (Lg) / 1,400 W (Sm)
Broil Power	4,000 W (Lg) / 3,600 W (Sm)
Convection Power	2,750 W (Lg) / 1,960 W (Sm)

BURNER PERFORMANCE

Total Number of Cooktop Burners	6 + Grill
Power of Front Left Burner BTU	18,000 and XLO (NG)
Power of Back Left Burner BTU	18,000 and XLO (NG)
Power of Back Center Burner BTU	18,000 (NG)
Power of Front Center Burner BTU	18,000 (NG)
Power of Center 12" Electric Griddle (W)	N/A
Power of Center 12" Electric Grill (W)	2,000 W
Power of Far Right 12" Electric Griddle (W)	N/A
Power of Back Right Burner BTU	18,000 and XLO (NG)
Power of Front Right Burner BTU	22,000 and XLO (NG)

DIMENSIONS & WEIGHT

Overall Appliance Dimensions (HxWxD) (in)	35 7/8"–36 3/4" x 47 15/16" x 28 3/4"
Required Cutout Size (HxWxD) (in)	35 7/8"–36 3/4" x 48" x 24"–25 1/8"
Adjustable Range Height (in.)	7/8"
Net Weight (lbs)	530 lbs

WARRANTY

Limited Warranty, Entire Appliance, Parts and Labor	2 Year
---	--------

FEATURES & BENEFITS

- ★ - Patented Pedestal Star® Burner with QuickClean Base® designed for easy surface cleaning and superior heat spread for any size pan
- ★ - Powerful 22,000 BTU (NG) burner (front right)
- ★ - Precision simmering capabilities as low as 100°F (375 BTU) with 4 ExtraLow® Simmer burners
- ★ - SoftClose® hinges for ultra smooth closing of the oven door
- ★ - Cleans both ovens simultaneously in just 2 hours

TECHNICAL DETAILS

Circuit Breaker (A)	50 A
Volts (V)	240 / 208 V
Frequency (Hz)	60 Hz
Plug Type	No Plug
Power Cord Length (in)	Purchase Separately
Energy Source	Gas and Electric
Gas Type	Natural Gas 15 mbar (USA)
Alternative Gas Type	Liquid Gas 27.5 mbar (USA)

See page 25 for optional accessories.

PRD484NCGU
48-INCH DUAL-FUEL PRO GRAND® RANGE WITH GRIDDLE AND GRILL
 PROFESSIONAL SERIES, COMMERCIAL-DEPTH, PORCELAIN COOKTOP SURFACE



GENERAL PROPERTIES

Oven Capacity	5.7 / 2.5 cu. ft.
Cooking Modes - Main / Large Cavity	Bake, Convection Bake, Broil, Convection Broil, Roast, Convection Roast, Self Clean, Keep Warm
Cooking Modes - Small Cavity	Bake, Convection Bake, Broil, Convection Broil, Roast, Convection Roast, Self Clean, Proof
Additional Features	Meat Probe, Sabbath Function, Cook Timer, Kitchen Timer
Cleaning Type	Self Clean (Both)
Type of Grate	Continuous Cast Iron
Controls	Metal Knobs and LCD Display
Warming Drawer	No
Sealed Burners	Yes

OVEN PERFORMANCE

Bake Power	2,000 W (Lg) / 1,400 W (Sm)
Broil Power	4,000 W (Lg) / 3,600 W (Sm)
Convection Power	2,750 W (Lg) / 1,960 W (Sm)

BURNER PERFORMANCE

Total Number of Cooktop Burners	4 + Griddle + Grill
Power of Front Left Burner BTU	18,000 and XLO (NG)
Power of Back Left Burner BTU	18,000 and XLO (NG)
Power of Back Center Burner BTU	18,000 and XLO (NG)
Power of Front Center Burner BTU	22,000 and XLO (NG)
Power of Center 12" Electric Griddle (W)	N/A
Power of Center 12" Electric Grill (W)	2,000 W
Power of Far Right 12" Electric Griddle (W)	1,630 W
Power of Back Right Burner BTU	N/A
Power of Front Right Burner BTU	N/A

DIMENSIONS & WEIGHT

Overall Appliance Dimensions (HxWxD) (in)	35 7/8" - 36 3/4" x 47 15/16" x 28 3/4"
Required Cutout Size (HxWxD) (in)	35 7/8" - 36 3/4" x 48" x 24" - 25 1/8"
Adjustable Range Height (in.)	7/8"
Net Weight (lbs)	530 lbs

WARRANTY

Limited Warranty, Entire Appliance, Parts and Labor	2 Year
---	--------

FEATURES & BENEFITS

- ★ - Patented Pedestal Star® Burner with QuickClean Base® designed for easy surface cleaning and superior heat spread for any size pan
- ★ - Powerful 22,000 BTU (NG) burner (front right)
- ★ - Precision simmering capabilities as low as 100°F (375 BTU) with 4 ExtraLow® Simmer burners
- ★ - SoftClose® hinges for ultra smooth closing of the oven door
- ★ - Cleans both ovens simultaneously in just 2 hours

TECHNICAL DETAILS

Circuit Breaker (A)	50 A
Volts (V)	240 / 208 V
Frequency (Hz)	60 Hz
Plug Type	No Plug
Power Cord Length (in)	Purchase Separately
Energy Source	Gas and Electric
Gas Type	Natural Gas 15 mbar (USA)
Alternative Gas Type	Liquid Gas 27.5 mbar (USA)

PRD48JD SGU
48-INCH DUAL-FUEL PRO GRAND® RANGE WITH STEAM AND GRIDDLE
 PROFESSIONAL SERIES, COMMERCIAL-DEPTH, PORCELAIN COOKTOP SURFACE



GENERAL PROPERTIES

Oven Capacity	5.1 / 1.4 cu. ft.
Cooking Modes - Main / Large Cavity	Bake, Convection Bake, Broil, Convection Broil, Roast, Convection Roast, Self clean, Keep Warm
Cooking Modes - Small Cavity	Steam, True Convection, Steam/Convection, Reheat, Proof, Slow Cook, Defrost, Easy Cook®
Additional Features	Meat Probe, Sabbath Function, Cook Timer, Kitchen Timer
Cleaning Type	Self Clean (Primary)
Type of Grate	Continuous Cast Iron
Controls	Metal Knobs and LCD Display
Warming Drawer	1.1 cu. ft. - Low, Med, High
Sealed Burners	Yes

OVEN PERFORMANCE

Bake Power	2,000 W (Lg) / 1,960 W (Sm)
Broil Power	4,000 W (Lg)
Convection Power	2,750 W (Lg)

BURNER PERFORMANCE

Total Number of Cooktop Burners	6 + Griddle
Power of Front Left Burner BTU	18,000 and XLO (NG)
Power of Back Left Burner BTU	18,000 and XLO (NG)
Power of Back Center Burner BTU	18,000 (NG)
Power of Front Center Burner BTU	18,000 (NG)
Power of Center 12" Electric Griddle (W)	1,630 W
Power of Center 12" Electric Grill (W)	N/A
Power of Far Right 12" Electric Griddle (W)	N/A
Power of Back Right Burner BTU	18,000 and XLO (NG)
Power of Front Right Burner BTU	22,000 and XLO (NG)

DIMENSIONS & WEIGHT

Overall Appliance Dimensions (HxWxD) (in)	35 7/8" - 36 3/4" x 47 15/16" x 28 3/4"
Required Cutout Size (HxWxD) (in)	35 7/8" - 36 3/4" x 48" x 24" - 25 1/8"
Adjustable Range Height (in.)	7/8"
Net Weight (lbs)	530 lbs

WARRANTY

Limited Warranty, Entire Appliance, Parts and Labor	2 Year
---	--------

FEATURES & BENEFITS

- ★ - The only professional range on the market with a built-in steam oven and warming drawer
- ★ - 27 Easy Cook® food programs. Pre-programmed modes automatically set the oven temperature and humidity to ensure perfect cooking results
- ★ - Patented Pedestal Star® Burner with QuickClean Base® designed for easy surface cleaning and superior heat spread for any size pan
- ★ - Powerful 22,000 BTU (NG) burner (front right)
- ★ - Precision simmering capabilities as low as 100°F (375 BTU) with 4 ExtraLow® Simmer burners

TECHNICAL DETAILS

Circuit Breaker (A)	50 A
Volts (V)	240 / 208 V
Frequency (Hz)	60 Hz
Plug Type	No Plug
Power Cord Length (in)	Purchase Separately
Energy Source	Gas and Electric
Gas Type	Natural Gas 15 mbar (USA)
Alternative Gas Type	Liquid Gas 27.5 mbar (USA)

PRD48NLSGU
48-INCH DUAL-FUEL PRO GRAND® RANGE WITH
STEAM AND GRILL
 PROFESSIONAL SERIES, COMMERCIAL-DEPTH, PORCELAIN COOKTOP SURFACE



GENERAL PROPERTIES	
Oven Capacity	5.1 / 1.4 cu. ft.
Cooking Modes - Main / Large Cavity	
Bake, Convection Bake, Broil, Convection Broil, Roast, Convection Roast, Self clean, Keep Warm	
Cooking Modes - Small Cavity	
Steam, True Convection, Steam/Convection, Reheat, Proof, Slow Cook, Defrost, Easy Cook®	
Additional Features	
Meat Probe, Sabbath Function, Cook Timer, Kitchen Timer	
Cleaning Type	Self Clean (Primary)
Type of Grate	Continuous Cast Iron
Controls	Metal Knobs and LCD Display
Warming Drawer	1.1 cu. ft. - Low, Med, High
Sealed Burners	Yes
OVEN PERFORMANCE	
Bake Power	2,000 W (Lg) / 1,960 W (Sm)
Broil Power	4,000 W (Lg)
Convection Power	2,750 W (Lg)
BURNER PERFORMANCE	
Total Number of Cooktop Burners	6 + Grill
Power of Front Left Burner BTU	18,000 and XLO (NG)
Power of Back Left Burner BTU	18,000 and XLO (NG)
Power of Back Center Burner BTU	18,000 (NG)
Power of Front Center Burner BTU	18,000 (NG)
Power of Center 12" Electric Griddle (W)	N/A
Power of Center 12" Electric Grill (W)	2,000 W
Power of Far Right 12" Electric Griddle (W)	N/A
Power of Back Right Burner BTU	18,000 and XLO (NG)
Power of Front Right Burner BTU	22,000 and XLO (NG)
DIMENSIONS & WEIGHT	
Overall Appliance Dimensions (HxWxD) (in)	35 7/8"-36 3/4" x 47 15/16" x 28 3/4"
Required Cutout Size (HxWxD) (in)	35 7/8"-36 3/4" x 48" x 24"-25 1/8"
Adjustable Range Height (in.)	7/8"
Net Weight (lbs)	530 lbs
WARRANTY	
Limited Warranty, Entire Appliance, Parts and Labor	2 Year

FEATURES & BENEFITS

- ★ - The only range in the market with a steam and convection combination oven, plus a full-size convection oven and a warming drawer
- ★ - 27 Easy Cook® food programs. Pre-programmed modes automatically set the oven temperature and humidity to ensure perfect cooking results
- ★ - Patented Pedestal Star® Burner with QuickClean Base® designed for easy surface cleaning and superior heat spread for any size pan
- ★ - Powerful 22,000 BTU (NG) burner (front right)
- ★ - Precision simmering capabilities as low as 100°F (375 BTU) with 4 ExtraLow® Simmer burners

TECHNICAL DETAILS

Circuit Breaker (A)	50 A
Volts (V)	240 / 208 V
Frequency (Hz)	60 Hz
Plug Type	No Plug
Power Cord Length (in)	Purchase Separately
Energy Source	Gas and Electric
Gas Type	Natural Gas 15 mbar (USA)
Alternative Gas Type	Liquid Gas 27.5 mbar (USA)

See page 25 for optional accessories.

PRD48NCSGU
48-INCH DUAL-FUEL PRO GRAND® RANGE WITH
STEAM, GRIDDLE AND GRILL
 PROFESSIONAL SERIES, COMMERCIAL-DEPTH, PORCELAIN COOKTOP SURFACE



GENERAL PROPERTIES	
Oven Capacity	5.1 / 1.4 cu. ft.
Cooking Modes - Main / Large Cavity	
Bake, Convection Bake, Broil, Convection Broil, Roast, Convection Roast, Self clean, Keep Warm	
Cooking Modes - Small Cavity	
Steam, True Convection, Steam/Convection, Reheat, Proof, Slow Cook, Defrost, Easy Cook®	
Additional Features	
Meat Probe, Sabbath Function, Cook Timer, Kitchen Timer	
Cleaning Type	Self Clean (Primary)
Type of Grate	Continuous Cast Iron
Controls	Metal Knobs and LCD Display
Warming Drawer	1.1 cu. ft. - Low, Med, High
Sealed Burners	Yes
OVEN PERFORMANCE	
Bake Power	2,000 W (Lg) / 1,960 W (Sm)
Broil Power	4,000 W (Lg)
Convection Power	2,750 W (Lg)
BURNER PERFORMANCE	
Total Number of Cooktop Burners	4 + Griddle + Grill
Power of Front Left Burner BTU	18,000 and XLO (NG)
Power of Back Left Burner BTU	18,000 and XLO (NG)
Power of Back Center Burner BTU	18,000 and XLO (NG)
Power of Front Center Burner BTU	22,000 and XLO (NG)
Power of Center 12" Electric Griddle (W)	N/A
Power of Center 12" Electric Grill (W)	2,000 W
Power of Far Right 12" Electric Griddle (W)	1,630 W
Power of Back Right Burner BTU	N/A
Power of Front Right Burner BTU	N/A
DIMENSIONS & WEIGHT	
Overall Appliance Dimensions (HxWxD) (in)	35 7/8"-36 3/4" x 47 15/16" x 28 3/4"
Required Cutout Size (HxWxD) (in)	35 7/8"-36 3/4" x 48" x 24"-25 1/8"
Adjustable Range Height (in.)	7/8"
Net Weight (lbs)	530 lbs
WARRANTY	
Limited Warranty, Entire Appliance, Parts and Labor	2 Year

FEATURES & BENEFITS

- ★ - The only range in the market with a steam and convection combination oven, plus a full-size convection oven and a warming drawer
- ★ - 27 Easy Cook® food programs. Pre-programmed modes automatically set the oven temperature and humidity to ensure perfect cooking results
- ★ - Patented Pedestal Star® Burner with QuickClean Base® designed for easy surface cleaning and superior heat spread for any size pan
- ★ - Powerful 22,000 BTU (NG) burner (front right)
- ★ - Precision simmering capabilities as low as 100°F (375 BTU) with 4 ExtraLow® Simmer burners

TECHNICAL DETAILS

Circuit Breaker (A)	50 A
Volts (V)	240 / 208 V
Frequency (Hz)	60 Hz
Plug Type	No Plug
Power Cord Length (in)	Purchase Separately
Energy Source	Gas and Electric
Gas Type	Natural Gas 15 mbar (USA)
Alternative Gas Type	Liquid Gas 27.5 mbar (USA)

See page 25 for optional accessories.

PRG486JDG
48-INCH GAS PRO GRAND® RANGE WITH GRIDDLE
 PROFESSIONAL SERIES, COMMERCIAL-DEPTH, PORCELAIN COOKTOP SURFACE



GENERAL PROPERTIES	
Oven Capacity	5.5 / 2.4 cu. ft.
Cooking Modes - Main / Large Cavity	
Bake, Convection Bake, Broil, Roast, Self Clean, Keep Warm	
Cooking Modes - Small Cavity	
Bake, Convection Bake, Broil, Roast, Self Clean, Proof	
Additional Features	
Meat Probe, Sabbath Function, Cook Timer, Kitchen Timer	
Cleaning Type	Self Clean (Both)
Type of Grate	Continuous Cast Iron
Controls	Metal Knobs and LCD Display
Warming Drawer	No
Sealed Burners	Yes

OVEN PERFORMANCE	
Bake Power	30,000 BTU NG (Lg) / 15,000 BTU NG (Sm)
Broil Power	17,000 BTU NG (Lg) / 9,000 BTU NG (Sm)
Convection Power	N/A

BURNER PERFORMANCE	
Total Number of Cooktop Burners	6 + Griddle
Power of Front Left Burner BTU	18,000 and XLO (NG)
Power of Back Left Burner BTU	18,000 and XLO (NG)
Power of Back Center Burner BTU	18,000 (NG)
Power of Front Center Burner BTU	18,000 (NG)
Power of Center 12" Electric Griddle (W)	1,630 W
Power of Center 12" Electric Grill (W)	N/A
Power of Far Right 12" Electric Griddle (W)	N/A
Power of Back Right Burner BTU	18,000 and XLO (NG)
Power of Front Right Burner BTU	22,000 and XLO (NG)

DIMENSIONS & WEIGHT	
Overall Appliance Dimensions (HxWxD) (in)	35 7/8"–36 3/4" x 47 15/16" x 28 3/4"
Required Cutout Size (HxWxD) (in)	35 7/8"–36 3/4" x 48" x 24"–25 1/8"
Adjustable Range Height (in.)	7/8"
Net Weight (lbs)	530 lbs

ACCESSORIES (INCLUDED)
 3 X Telescopic Rack, 2 X Telescopic Rack - Small, 2 X Temperature Sensor, 1 X Island Trim, 1 X Broiler Pan Small, 1 X Broiler Pan

WARRANTY	
Limited Warranty, Entire Appliance, Parts and Labor	2 Year

Also Available:
 PRL486JDG - LP

FEATURES & BENEFITS

- ★ - Patented Pedestal Star® Burner with QuickClean Base® designed for easy surface cleaning and superior heat spread for any size pan
- ★ - Powerful 22,000 BTU (NG) burner (front right)
- ★ - Precision simmering capabilities as low as 100°F (375 BTU) with 4 ExtraLow® Simmer burners
- ★ - SoftClose® hinges for ultra smooth closing of the oven door
- ★ - Superfast 2-hour self-clean mode—fastest in the industry

TECHNICAL DETAILS

Circuit Breaker (A)	20 A
Volts (V)	120 V
Frequency (Hz)	60 Hz
Plug Type	120V-3 Prong NEMA 5-20
Power Cord Length (in)	96"
Energy Source	Gas
Gas Type	Natural Gas 15 mbar (USA)
Alternative Gas Type	Liquid Gas 27.5 mbar (USA)

See page 25 for optional accessories.

PRG486NLG
48-INCH GAS PRO GRAND® RANGE WITH GRILL
 PROFESSIONAL SERIES, COMMERCIAL-DEPTH, PORCELAIN COOKTOP SURFACE



GENERAL PROPERTIES	
Oven Capacity	5.5 / 2.4 cu. ft.
Cooking Modes - Main / Large Cavity	
Bake, Convection Bake, Broil, Roast, Self Clean, Keep Warm	
Cooking Modes - Small Cavity	
Bake, Convection Bake, Broil, Roast, Self Clean, Proof	
Additional Features	
Meat Probe, Sabbath Function, Cook Timer, Kitchen Timer	
Cleaning Type	Self Clean (Both)
Type of Grate	Continuous Cast Iron
Controls	Metal Knobs and LCD Display
Warming Drawer	No
Sealed Burners	Yes

OVEN PERFORMANCE	
Bake Power	30,000 BTU NG (Lg) / 15,000 BTU NG (Sm)
Broil Power	17,000 BTU NG (Lg) / 9,000 BTU NG (Sm)
Convection Power	N/A

BURNER PERFORMANCE	
Total Number of Cooktop Burners	6 + Grill
Power of Front Left Burner BTU	18,000 and XLO (NG)
Power of Back Left Burner BTU	18,000 and XLO (NG)
Power of Back Center Burner BTU	18,000 (NG)
Power of Front Center Burner BTU	18,000 (NG)
Power of Center 12" Electric Griddle (W)	N/A
Power of Center 12" Electric Grill (W)	1,630 W
Power of Far Right 12" Electric Griddle (W)	N/A
Power of Back Right Burner BTU	18,000 and XLO (NG)
Power of Front Right Burner BTU	22,000 and XLO (NG)

DIMENSIONS & WEIGHT	
Overall Appliance Dimensions (HxWxD) (in)	35 7/8"–36 3/4" x 47 15/16" x 28 3/4"
Required Cutout Size (HxWxD) (in)	35 7/8"–36 3/4" x 48" x 24"–25 1/8"
Adjustable Range Height (in.)	7/8"
Net Weight (lbs)	530 lbs

ACCESSORIES (INCLUDED)
 3 X Telescopic Rack, 1 X Telescopic Rack - Small, 1 X Temperature Sensor, 1 X Island Trim, 1 X Broiler Pan Small, 1 X Broiler Pan

WARRANTY	
Limited Warranty, Entire Appliance, Parts and Labor	2 Year

Also Available:
 PRL486NLG - LP

FEATURES & BENEFITS

- ★ - Patented Pedestal Star® Burner with QuickClean Base® designed for easy surface cleaning and superior heat spread for any size pan
- ★ - Powerful 22,000 BTU (NG) burner (front right)
- ★ - Precision simmering capabilities as low as 100°F (375 BTU) with 4 ExtraLow® Simmer burners
- ★ - SoftClose® hinges for ultra smooth closing of the oven door
- ★ - Superfast 2-hour self-clean mode—fastest in the industry

TECHNICAL DETAILS

Circuit Breaker (A)	20 A
Volts (V)	120 V
Frequency (Hz)	60 Hz
Plug Type	120V-3 Prong
Power Cord Length (in)	96"
Energy Source	Gas
Gas Type	Natural Gas 15 mbar (USA)
Alternative Gas Type	Liquid Gas 27.5 mbar (USA)

See page 25 for optional accessories.

PRL486JDG

48-INCH GAS PRO GRAND® RANGE WITH GRIDDLE (LP)

PROFESSIONAL SERIES, COMMERCIAL-DEPTH, PORCELAIN COOKTOP SURFACE



GENERAL PROPERTIES	
Oven Capacity	5.5 / 2.4 cu. ft.
Cooking Modes - Main / Large Cavity	
Bake, Convection Bake, Broil, Roast, Self Clean, Keep Warm	
Cooking Modes - Small Cavity	
Bake, Convection Bake, Broil, Roast, Self Clean, Proof	
Additional Features	
Meat Probe, Sabbath Function, Cook Timer, Kitchen Timer	
Cleaning Type	Self Clean (Both)
Type of Grate	Continuous Cast Iron
Controls	Metal Knobs and LCD Display
Warming Drawer	No
Sealed Burners	Yes

OVEN PERFORMANCE	
Bake Power	25,000 BTU NG (Lg) / 12,300 BTU NG (Sm)
Broil Power	17,000 BTU NG (Lg) / 9,000 BTU NG (Sm)
Convection Power	N/A

BURNER PERFORMANCE	
Total Number of Cooktop Burners	6 + Griddle
Power of Front Left Burner BTU	15,000 and XLO (LP)
Power of Back Left Burner BTU	15,000 and XLO (LP)
Power of Back Center Burner BTU	15,000 (LP)
Power of Front Center Burner BTU	15,000 (LP)
Power of Center 12" Electric Griddle (W)	1,630 W
Power of Center 12" Electric Grill (W)	N/A
Power of Far Right 12" Electric Griddle (W)	N/A
Power of Back Right Burner BTU	15,000 and XLO (LP)
Power of Front Right Burner BTU	18,000 and XLO (LP)

DIMENSIONS & WEIGHT	
Overall Appliance Dimensions (HxWxD) (in)	35 7/8"-36 3/4" x 47 15/16" x 28 3/4"
Required Cutout Size (HxWxD) (in)	35 7/8"-36 3/4" x 48" x 24"-25 1/8"
Adjustable Range Height (in.)	7/8"
Net Weight (lbs)	530 lbs

ACCESSORIES (INCLUDED)	
3 X Telescopic Rack, 2 X Telescopic Rack - Small, 2 X Temperature Sensor, 1 X Island Trim, 1 X Broiler Pan Small, 1 X Broiler Pan	

WARRANTY	
Limited Warranty, Entire Appliance, Parts and Labor	2 Year

Also Available:
PRG486JDG - Natural Gas

FEATURES & BENEFITS

- ★ - Patented Pedestal Star® Burner with QuickClean Base® designed for easy surface cleaning and superior heat spread for any size pan
- ★ - Powerful 18,000 BTU (LP) burner (front right)
- ★ - Precision simmering capabilities as low as 100°F (375 BTU) with 4 ExtraLow® Simmer burners
- ★ - SoftClose® hinges for ultra smooth closing of the oven door
- ★ - Superfast 2-hour self-clean mode—fastest in the industry

TECHNICAL DETAILS

Circuit Breaker (A)	20 A
Volts (V)	120 V
Frequency (Hz)	60 Hz
Plug Type	120V-3 Prong NEMA 5-20
Power Cord Length (in)	96"
Energy Source	Gas
Gas Type	Liquid Gas 27.5 mbar (USA)
Alternative Gas Type	Natural Gas 15 mbar (USA)

See page 25 for optional accessories.

PRL486NLG

48-INCH GAS PRO GRAND® RANGE WITH GRILL (LP)

PROFESSIONAL SERIES, COMMERCIAL-DEPTH, PORCELAIN COOKTOP SURFACE



GENERAL PROPERTIES	
Oven Capacity	5.5 / 2.4 cu. ft.
Cooking Modes - Main / Large Cavity	
Bake, Convection Bake, Broil, Roast, Self Clean, Keep Warm	
Cooking Modes - Small Cavity	
Bake, Convection Bake, Broil, Roast, Self Clean, Proof	
Additional Features	
Meat Probe, Sabbath Function, Cook Timer, Kitchen Timer	
Cleaning Type	Self Clean (Both)
Type of Grate	Continuous Cast Iron
Controls	Metal Knobs and LCD Display
Warming Drawer	No
Sealed Burners	Yes

OVEN PERFORMANCE	
Bake Power	25,000 BTU NG (Lg) / 12,300 BTU NG (Sm)
Broil Power	17,000 BTU NG (Lg) / 9,000 BTU NG (Sm)
Convection Power	N/A

BURNER PERFORMANCE	
Total Number of Cooktop Burners	6 + Grill
Power of Front Left Burner BTU	15,000 and XLO (LP)
Power of Back Left Burner BTU	15,000 and XLO (LP)
Power of Back Center Burner BTU	15,000 (LP)
Power of Front Center Burner BTU	15,000 (LP)
Power of Center 12" Electric Griddle (W)	N/A
Power of Center 12" Electric Grill (W)	1,630 W
Power of Far Right 12" Electric Griddle (W)	N/A
Power of Back Right Burner BTU	15,000 and XLO (LP)
Power of Front Right Burner BTU	18,000 and XLO (LP)

DIMENSIONS & WEIGHT	
Overall Appliance Dimensions (HxWxD) (in)	35 7/8"-36 3/4" x 47 15/16" x 28 3/4"
Required Cutout Size (HxWxD) (in)	35 7/8"-36 3/4" x 48" x 24"-25 1/8"
Adjustable Range Height (in.)	7/8"
Net Weight (lbs)	530 lbs

ACCESSORIES (INCLUDED)	
3 X Telescopic Rack, 1 X Telescopic Rack - Small, 1 X Temperature Sensor, 1 X Island Trim, 1 X Broiler Pan Small, 1 X Broiler Pan	

WARRANTY	
Limited Warranty, Entire Appliance, Parts and Labor	2 Year

Also Available:
PRG486NLG - Natural Gas

FEATURES & BENEFITS

- ★ - Patented Pedestal Star® Burner with QuickClean Base® designed for easy surface cleaning and superior heat spread for any size pan
- ★ - Powerful 18,000 BTU (LP) burner (front right)
- ★ - Precision simmering capabilities as low as 100°F (375 BTU) with 4 ExtraLow® Simmer burners
- ★ - SoftClose® hinges for ultra smooth closing of the oven door
- ★ - Superfast 2-hour self-clean mode—fastest in the industry

TECHNICAL DETAILS

Circuit Breaker (A)	20 A
Volts (V)	120 V
Frequency (Hz)	60 Hz
Plug Type	120V-3 Prong
Power Cord Length (in)	96"
Energy Source	Gas
Gas Type	Liquid Gas 27.5 mbar (USA)
Alternative Gas Type	Natural Gas 15 mbar (USA)

See page 25 for optional accessories.

PRD606RCG
60-INCH DUAL-FUEL PRO GRAND® RANGE WITH GRILL AND GRIDDLE
 PROFESSIONAL SERIES, COMMERCIAL-DEPTH, PORCELAIN COOKTOP SURFACE



FEATURES & BENEFITS

- ★ - Largest Pro Range Oven capacity in the industry @ 10.6 cu. ft. overall (5.7 cu. ft. main oven & 4.9 cu. ft. secondary oven)
- ★ - Superior grilling results, 2000 watt Indoor Electric Grill with Ceramic Briquettes in addition to 12" electric griddle and 6 powerful Star® Burners
- ★ - Patented Pedestal Star® Burner with QuickClean Base® designed for easy surface cleaning and superior heat spread for any size pan
- ★ - Powerful 22,000 BTU (NG) burner (front left)
- ★ - Precision simmering capabilities as low as 100°F (375 BTU) with 4 ExtraLow® Simmer burners
- ★ - SoftClose® hinges for ultra smooth closing of the oven door
- ★ - Two hour rapid self-cleaning

TECHNICAL DETAILS

Circuit Breaker (A)	50 A
Volts (V)	240 / 208 V
Frequency (Hz)	60 Hz
Plug Type	240V-4 Prong
Power Cord Length (in)	Purchase Separately
Energy Source	Gas and Electric
Gas Type	Natural Gas 15 mbar (USA)
Alternative Gas Type	Liquid Gas 27.5 mbar (USA)

ACCESSORIES (INCLUDED)

1 X Nozzle Set for Liquid Gas, 3 X Telescopic Racks, 3 X Telescopic Racks - Secondary Oven, 1 X Temperature Sensor, 1 X Island Trim, 1 X Grill Plate, 1 X Broiler Pan Small, 1 X Broiler Pan, Probe

WARRANTY

Limited Warranty, Entire Appliance, Parts and Labor	2 Year
---	--------

GENERAL PROPERTIES

Oven Capacity	5.7 / 4.9 cu. ft.
Cooking Modes - Main / Large Cavity	Bake, Convection Bake, Broil, Convection Broil, Roast, Convection Roast, Self Clean, Keep Warm
Cooking Modes - Small Cavity	Bake, Convection Bake, Broil, Convection Broil, Roast, Convection Roast, Self Clean, Proof
Additional Features	Meat Probe, Sabbath Function, Cook Timer, Kitchen Timer
Cleaning Type	Self Clean (Both)
Type of Grate	Continuous Cast Iron
Controls	Metal Knobs and LCD Display
Warming Drawer	No
Sealed Burners	Yes

OVEN PERFORMANCE

Bake Power	2,000 W (Lg) / 2,000 W (Sm)
Broil Power	3,600 W (Lg) / 3,000 W (Sm)
Convection Power	2,750 W (Lg) / 2,750 W (Sm)

BURNER PERFORMANCE

Total Number of Cooktop Burners	6 + Griddle + Grill
Power of Front Left Burner BTU	22,000 (NG) / 18,000 (LP) and XLO
Power of Back Left Burner BTU	12,500 (NG) / 11,000 (LP) and XLO
Power of Back Center Burner BTU	12,500 (NG) / 11,000 (LP)
Power of Front Center Burner BTU	18,000 (NG) / 15,000 (LP)
Power of Center 12" Electric Griddle (W)	N/A
Power of Center 12" Electric Grill (W)	2,000 W
Power of Center 24" Dual Zone Electric Griddle	N/A
Power of Far Right 12" Electric Griddle (W)	1,630 W
Power of Back Right Burner BTU	15,000 (NG) / 9,100 (LP) and XLO
Power of Front Right Burner BTU	18,000 (NG) / 15,000 (LP) and XLO

DIMENSIONS & WEIGHT

Overall Appliance Dimensions (HxWxD) (in)	35 7/8"-36 3/4" x 59 15/16" x 28 3/4"
Required Cutout Size (HxWxD) (in)	35 7/8"-36 3/4" x 60" x 24"-25 1/8"
Adjustable Range Height (in.)	7/8"
Net Weight (lbs)	668 lbs

See page 26 for optional accessories.

PRD606REG
60-INCH DUAL-FUEL PRO GRAND® RANGE WITH DOUBLE GRIDDLE
 PROFESSIONAL SERIES, COMMERCIAL-DEPTH, PORCELAIN COOKTOP SURFACE



FEATURES & BENEFITS

- ★ - Largest Pro Range Oven capacity in the industry @ 10.6 cu. ft. overall (5.7 cu. ft. main oven & 4.9 cu. ft. secondary oven)
- ★ - 24" Double griddle with two independently controlled zones (left & right)
- ★ - Patented Pedestal Star® Burner with QuickClean Base® designed for easy surface cleaning and superior heat spread for any size pan
- ★ - Powerful 22,000 BTU (NG) burner (front left)
- ★ - Precision simmering capabilities as low as 100°F (375 BTU) with 4 ExtraLow® Simmer burners
- ★ - SoftClose® hinges for ultra smooth closing of the oven door
- ★ - Two hour rapid self-cleaning

TECHNICAL DETAILS

Circuit Breaker (A)	50 A
Volts (V)	240 / 208 V
Frequency (Hz)	60 Hz
Plug Type	240V-4 Prong
Power Cord Length (in)	Purchase Separately
Energy Source	Gas and Electric
Gas Type	Natural Gas 15 mbar (USA)
Alternative Gas Type	Liquid Gas 27.5 mbar (USA)

ACCESSORIES (INCLUDED)

1 X Nozzle Set for Liquid Gas, 3 X Telescopic Racks, 3 X Telescopic Racks - Secondary Oven, 1 X Temperature Sensor, 1 X Island Trim, 1 X Broiler Pan Small, 1 X Broiler Pan, Probe

WARRANTY

Limited Warranty, Entire Appliance, Parts and Labor	2 Year
---	--------

See page 26 for optional accessories.

GENERAL PROPERTIES

Oven Capacity	5.7 / 4.9 cu. ft.
Cooking Modes - Main / Large Cavity	Bake, Convection Bake, Broil, Convection Broil, Roast, Convection Roast, Self Clean, Keep Warm
Cooking Modes - Small Cavity	Bake, Convection Bake, Broil, Convection Broil, Roast, Convection Roast, Self Clean, Proof
Additional Features	Meat Probe, Sabbath Function, Cook Timer, Kitchen Timer
Cleaning Type	Self Clean (Both)
Type of Grate	Continuous Cast Iron
Controls	Metal Knobs and LCD Display
Warming Drawer	No
Sealed Burners	Yes

OVEN PERFORMANCE

Bake Power	2,000 W (Lg) / 2,000 W (Sm)
Broil Power	3,600 W (Lg) / 3,000 W (Sm)
Convection Power	2,750 W (Lg) / 2,750 W (Sm)

BURNER PERFORMANCE

Total Number of Cooktop Burners	6 + Griddle
Power of Front Left Burner BTU	22,000 (NG) / 18,000 (LP) and XLO
Power of Back Left Burner BTU	12,500 (NG) / 11,000 (LP) and XLO
Power of Back Center Burner BTU	12,500 (NG) / 11,000 (LP)
Power of Front Center Burner BTU	18,000 (NG) / 15,000 (LP)
Power of Center 12" Electric Griddle (W)	N/A
Power of Center 12" Electric Grill (W)	N/A
Power of Center 24" Dual Zone Electric Griddle	1,630 W (Left & Right)
Power of Far Right 12" Electric Griddle (W)	N/A
Power of Back Right Burner BTU	15,000 (NG) / 9,100 (LP) and XLO
Power of Front Right Burner BTU	18,000 (NG) / 15,000 (LP) and XLO

DIMENSIONS & WEIGHT

Overall Appliance Dimensions (HxWxD) (in)	35 7/8"-36 3/4" x 59 15/16" x 28 3/4"
Required Cutout Size (HxWxD) (in)	35 7/8"-36 3/4" x 60" x 24"-25 1/8"
Adjustable Range Height (in.)	7/8"
Net Weight (lbs)	652 lbs

See page 26 for optional accessories.

PRD606RCSG
60-INCH DUAL-FUEL PRO GRAND® RANGE WITH
STEAM, GRILL AND GRIDDLE
 PROFESSIONAL SERIES, COMMERCIAL-DEPTH, PORCELAIN COOKTOP SURFACE



GENERAL PROPERTIES

Oven Capacity	5.7 / 1.4 cu. ft.
Cooking Modes - Main / Large Cavity	Bake, Convection Bake, Broil, Convection Broil, Roast, Convection Roast, Self clean, Keep Warm
Cooking Modes - Small Cavity	Steam, True Convection, Steam/Convection, Reheat, Proof, Slow Cook, Defrost, Easy Cook®
Additional Features	Meat Probe, Sabbath Function, Cook Timer, Kitchen Timer
Cleaning Type	Self Clean (Primary)
Type of Grate	Continuous Cast Iron
Controls	Metal Knobs and LCD Display
Warming Drawer	1.4 cu. ft.- Low, Med, High
Sealed Burners	Yes

OVEN PERFORMANCE

Bake Power	2,000 W (Lg) / 1,960 W (Sm)
Broil Power	3,600 W (Lg)
Convection Power	2,750 W (Lg)

BURNER PERFORMANCE

Total Number of Cooktop Burners	6 + Griddle + Grill
Power of Front Left Burner BTU	22,000 (NG) / 18,000 (LP) and XLO
Power of Back Left Burner BTU	12,500 (NG) / 11,000 (LP) and XLO
Power of Back Center Burner BTU	12,500 (NG) / 11,000 (LP)
Power of Front Center Burner BTU	18,000 (NG) / 15,000 (LP)
Power of Center 12" Electric Griddle (W)	1,630 W
Power of Center 12" Electric Grill (W)	2,000 W
Power of Center 24" Dual Zone Electric Griddle	N/A
Power of Far Right 12" Electric Griddle (W)	N/A
Power of Back Right Burner BTU	15,000 (NG) / 9,100 (LP) and XLO
Power of Front Right Burner BTU	18,000 (NG) / 15,000 (LP) and XLO

DIMENSIONS & WEIGHT

Overall Appliance Dimensions (HxWxD) (in)	35 7/8"-36 3/4" x 59 15/16" x 28 3/4"
Required Cutout Size (HxWxD) (in)	35 7/8"-36 3/4" x 60" x 24"-25 1/8"
Adjustable Range Height (in.)	7/8"
Net Weight (lbs)	610 lbs

FEATURES & BENEFITS

- ★ - Largest Pro Range Oven capacity in the industry @ 5.7 cu. ft. (large enough to fit a caterers full sheet pan)
- ★ - Superior grilling results, 2000 watt Indoor Electric Grill with Ceramic Briquettes in addition to 12" electric griddle and 6 powerful star burners
- ★ - The only professional range on the market with a built-in steam oven and warming drawer
- ★ - 27 Easy Cook® food programs. Pre-programmed modes automatically set the oven temperature and humidity to ensure perfect cooking results
- ★ - Patented Pedestal Star® Burner with QuickClean Base® designed for easy surface cleaning and superior heat spread for any size pan
- ★ - Powerful 22,000 BTU (NG) burner (front left)
- ★ - Precision simmering capabilities as low as 100°F (375 BTU) with 4 ExtraLow® Simmer burners

TECHNICAL DETAILS

Circuit Breaker (A)	50 A
Volts (V)	240 / 208 V
Frequency (Hz)	60 Hz
Plug Type	240V-4 Prong
Power Cord Length (in)	Purchase Separately
Energy Source	Gas and Electric
Gas Type	Natural Gas 15 mbar (USA)
Alternative Gas Type	Liquid Gas 27.5 mbar (USA)

ACCESSORIES (INCLUDED)

1 X Nozzle Set for Liquid Gas, 3 X Telescopic Racks, 2 X Temperature Sensor, 1 X Island Trim, 1 X STS Tray-GN1/3-Punched-40 mm Deep, 1 X STS Tray-GN1/3-Unpunched-40 mm Deep, 1 X STS Tray-GN2/3-Unpunched-40 mm Deep, 1 X STS Tray-GN2/3-Punched-40 mm Deep, 1 X STS Tray-GN2/3-Unpunched-28 mm Deep, 1 X Grid, 1 X Grill Plate, 1 X Broiler Pan Small, 1 X Broiler Pan

WARRANTY

Limited Warranty, Entire Appliance, Parts and Labor	2 Year
---	--------

See page 26 for optional accessories.

★ THERMADOR® EXCLUSIVE

PRD606RESG
60-INCH DUAL-FUEL PRO GRAND® RANGE WITH
STEAM AND DOUBLE GRIDDLE
 PROFESSIONAL SERIES, COMMERCIAL-DEPTH, PORCELAIN COOKTOP SURFACE



GENERAL PROPERTIES

Oven Capacity	5.7 / 1.4 cu. ft.
Cooking Modes - Main / Large Cavity	Bake, Convection Bake, Broil, Convection Broil, Roast, Convection Roast, Self clean, Keep Warm
Cooking Modes - Small Cavity	Steam, True Convection, Steam/Convection, Reheat, Proof, Slow Cook, Defrost, Easy Cook®
Additional Features	Meat Probe, Sabbath Function, Cook Timer, Kitchen Timer
Cleaning Type	Self Clean (Primary)
Type of Grate	Continuous Cast Iron
Controls	Metal Knobs and LCD Display
Warming Drawer	1.4 cu. ft.- Low, Med, High
Sealed Burners	Yes

OVEN PERFORMANCE

Bake Power	2,000 W (Lg) / 1,960 W (Sm)
Broil Power	3,600 W (Lg)
Convection Power	2,750 W (Lg)

BURNER PERFORMANCE

Total Number of Cooktop Burners	6 + Griddle
Power of Front Left Burner BTU	22,000 (NG) / 18,000 (LP) and XLO
Power of Back Left Burner BTU	12,500 (NG) / 11,000 (LP) and XLO
Power of Back Center Burner BTU	12,500 (NG) / 11,000 (LP)
Power of Front Center Burner BTU	18,000 (NG) / 15,000 (LP)
Power of Center 12" Electric Griddle (W)	N/A
Power of Center 12" Electric Grill (W)	N/A
Power of Center 24" Dual Zone Electric Griddle	1,630 W (Left & Right)
Power of Far Right 12" Electric Griddle (W)	N/A
Power of Back Right Burner BTU	15,000 (NG) / 9,100 (LP) and XLO
Power of Front Right Burner BTU	18,000 (NG) / 15,000 (LP) and XLO

DIMENSIONS & WEIGHT

Overall Appliance Dimensions (HxWxD) (in)	35 7/8"-36 3/4" x 59 15/16" x 28 3/4"
Required Cutout Size (HxWxD) (in)	35 7/8"-36 3/4" x 60" x 24"-25 1/8"
Adjustable Range Height (in.)	7/8"
Net Weight (lbs)	590 lbs

FEATURES & BENEFITS

- ★ - Largest Pro Range Oven capacity in the industry @ 5.7 cu. ft. (large enough to fit a caterers full sheet pan)
- ★ - 24" Double griddle with two independently controlled zones (left & right)
- ★ - The only professional range on the market with a built-in steam oven and warming drawer
- ★ - 27 Easy Cook® food programs. Pre-programmed modes automatically set the oven temperature and humidity to ensure perfect cooking results
- ★ - Patented Pedestal Star® Burner with QuickClean Base® designed for easy surface cleaning and superior heat spread for any size pan
- ★ - Powerful 22,000 BTU (NG) burner (front left)
- ★ - Precision simmering capabilities as low as 100°F (375 BTU) with 4 ExtraLow® Simmer burners

TECHNICAL DETAILS

Circuit Breaker (A)	50 A
Volts (V)	240 / 208 V
Frequency (Hz)	60 Hz
Plug Type	240V-4 Prong
Power Cord Length (in)	Purchase Separately
Energy Source	Gas and Electric
Gas Type	Natural Gas 15 mbar (USA)
Alternative Gas Type	Liquid Gas 27.5 mbar (USA)

ACCESSORIES (INCLUDED)

1 X Nozzle Set for Liquid Gas, 3 X Telescopic Racks, 2 X Temperature Sensor, 1 X Island Trim, 1 X STS Tray-GN1/3-Punched-40 mm Deep, 1 X STS Tray-GN1/3-Unpunched-40 mm Deep, 1 X STS Tray-GN2/3-Unpunched-40 mm Deep, 1 X STS Tray-GN2/3-Punched-40 mm Deep, 1 X STS Tray-GN2/3-Unpunched-28 mm Deep, 1 X Broiler Pan Small, 1 X Broiler Pan

WARRANTY

Limited Warranty, Entire Appliance, Parts and Labor	2 Year
---	--------

★ THERMADOR® EXCLUSIVE

See page 26 for optional accessories.

PRO GRAND® RANGES

PLANNING INFORMATION

MODEL OPTIONS

There are three sizes of Thermador Pro Grand® Ranges to choose from—36-inch, 48-inch and 60-inch—in your choice of all-gas or dual-fuel configurations. All models are 27-inches deep and available in stainless steel with porcelain cooktop. Be sure to reference the correct model information in this design guide.

INSTALLATION CONSIDERATIONS

The information in this design guide provides key features, product dimensions, cutouts and installation specifications. Before installing a Thermador Pro Grand Range, be sure to verify the cutout dimensions and electrical / gas connections. Also, always consult with the installation manual packed with the product for complete details before installing.

INSTALLATION OPTIONS

Thermador Pro Grand Ranges feature a bold, professional design and a commercial-depth of 27-inches. These ranges can be installed in a wall or island installation.

BACKGUARDS

When using the Flush Island Trim, Thermador recommends a minimum 12" (305 mm) rear clearance to a combustible surface (see Figure 1, Cabinet Clearances). Clearances from non-combustible materials are not part of the ANSI Z21.1 scope and are not certified by CSA. Clearances of less than 12" (305 mm) must be approved by the local codes and / or by the local authority having jurisdiction.

NATURAL GAS OR LP

Thermador Dual-Fuel Pro Grand Ranges are shipped by the factory to operate on natural gas. They must be converted for use with propane. Verify that the type of gas being used at the installation site matches the type of gas used by the appliance. If the location / job site requires conversion from natural gas to propane (LP), utilize the included LP kit. Field conversion must be done by qualified service personnel only. Please refer to the LP Conversion Instructions for further information.

HIGH ALTITUDE

A high altitude kit is available through Customer Services as service part number 746376.

VENTILATION REQUIREMENTS

We strongly recommend that a Thermador Professional® Wall or Island Hood or Custom Insert be installed with all Thermador Pro Grand Ranges. Downdraft ventilation should not be used. Do not install a microwave-hood combination above the cooktop, as these types of units do not provide the proper ventilation and are not suitable for use with Thermador Pro Grand Ranges.

Due to the 27-inch commercial-depth of Pro Grand Ranges, the PH Professional Series Wall Hoods or Professional Series Custom Inserts would provide the appropriate depth from the wall to correspond to these ranges.

For high output gas cooktops (60,000 BTU or greater), the minimum of one (1) CFM of ventilation per 100 BTU is recommended. If the cooktop has a grill or griddle, add 150 CFM to the estimated blower capacity. Additional blower capacity may be required for longer duct runs.

The following table indicates the ventilation hood options that are recommended for use with Thermador Pro Grand Ranges. Refer to the Ventilation section or www.thermador.com for a complete selection of Professional ventilation options, blowers, and accessories.

WIDTH	CONFIGURATION	VENTILATION OPTIONS
36"	4 Burners w/Grill OR Griddle	36" or 42" Pro Wall Hood 36" Chimney Wall Hood 42" Island Hood 36" Custom Insert
36"	6 Burners	36" or 42" Pro Wall Hood 36" Chimney Wall Hood 42" Island Hood 36" Custom Insert
48"	4 Burners w/Grill AND Griddle	48" or 54" Pro Wall Hood 48" Chimney Wall Hood 42" Island Hood 36" Custom Insert
48"	6 Burners w/Grill OR Griddle	48" or 54" Pro Wall Hood 48" Chimney Wall Hood 42" Island Hood 36" Custom Insert
60"	6 Burners with Grill AND Griddle OR 24" Griddle	60" Pro Wall Hood 60" Custom Insert

ELECTRICAL AND GAS SPECIFICATIONS

Be sure your appliance is properly installed and grounded by a qualified technician. Installation, electrical and gas connections, and grounding must comply with all applicable local codes.

GAS REQUIREMENTS AND HOOKUP

Verify that the type of gas being used at the installation site matches the type of gas used by the appliance. If an LP kit is utilized, conversion from natural gas to propane must be done by qualified service personnel only. Please refer to the LP Conversion Instructions for further information.

A manual gas shut-off valve must be installed external to the appliance, in a location accessible from the front, for the purpose of shutting off the gas supply. The supply line must not interfere with the back of the unit.

NATURAL GAS REQUIREMENTS:

Inlet Connection: 3/4" NPT external, 1/2" NPT internal (Minimum 3/4" diam. flex line)

Supply Pressure: 6" min. to 14" max. water column (14.9 to 34.9 mb)

Manifold Pressure: 5" water column (12.5 mb)

PROPANE GAS REQUIREMENTS:

Inlet Connection: 3/4" NPT external, 1/2" NPT internal (Minimum 3/4" diam. flex line)

Supply Pressure: 11" min. to 14" max. water column (27.4 mb to 34.9 mb)

Manifold Pressure: 10" water column (24.9 mb)

ALL-GAS:

Thermador Pro Grand All-Gas Ranges are equipped with a 3-wire plug and are designed to be connected to a 120V AC, 60 Hz, single-phase power supply. A dedicated circuit breaker is required.

MODEL	REQUIRED CIRCUIT BREAKER
	120V AC, 60 Hz
PRG366JG – NG	15 A
PRL366JG – LP	15 A
PRG364JDG – NG	20 A
PRG364NLG – NG	20 A
PRL364JDG – LP	20 A
PRL364NLG – LP	20 A
PRG486JDG – NG	20 A
PRG486NLG – NG	20 A
PRL486JDG – LP	20 A
PRL486NLG – LP	20 A

PRO GRAND® RANGES

PLANNING INFORMATION

DUAL-FUEL:

Thermador Pro Grand Dual-Fuel Ranges are dual rated, designed to be connected to either 240 / 208V AC, 60 Hz, 4-wire, single-phase power supply. The connection may be made with a range supply cord kit (purchased separately) or by hard-wiring to the power supply. A dedicated circuit breaker is required.

MODEL	REQUIRED CIRCUIT BREAKER
	240 / 208V AC, 60Hz
PRD366JGU	40 A
PRD364JDGU	40 A
PRD364NLGU	40 A
PRD486JDGU	50 A
PRD486NLGU	50 A
PRD484NCGU	50 A
PRD48JDSGU	50 A
PRD48NLSGU	50 A
PRD48NCSGU	50 A
PRD606RCG	50 A
PRD606REG	50 A
PRD606RCSG	50 A
PRD606RESG	50 A

ELECTRICAL SUPPLY

IMPORTANT: The cord supplied with gas ranges having an electric griddle requires a NEMA 5-20 receptacle as shown here. Local codes may require a different wiring method.

NEMA 5-20 RECEPTACLE



PLUG



WARNING: This appliance is equipped with a three-prong grounding plug for protection against shock hazard and should be plugged directly into a properly grounded receptacle. **DO NOT** cut or remove the grounding prong from this plug. **DO NOT ALTER THIS PLUG.**

ELECTRICAL AND GAS LOCATIONS

Typical placement of the electrical and gas supply can be found within the "Cutout and Range Dimensions" located on the installation pages. Alternate placement within the supply zone is acceptable. Dual-Fuel ranges may be connected to the power supply with a range supply cord kit (sold separately) or by hard-wiring to the power supply. All-gas ranges may be connected to the power supply with the supplied range cord or by hard-wiring. It is the responsibility of the installer to provide the proper wiring components (cord or conduit and wires) and complete the electrical connection as dictated by local codes and ordinances and / or the National Electric Code. The units must be properly grounded.

Installation of the range must be planned so that the rough-in of the junction box for the receptacle or conduit connection will allow maximum clearance to the rear of the unit.

36-INCH RANGE DIMENSIONS

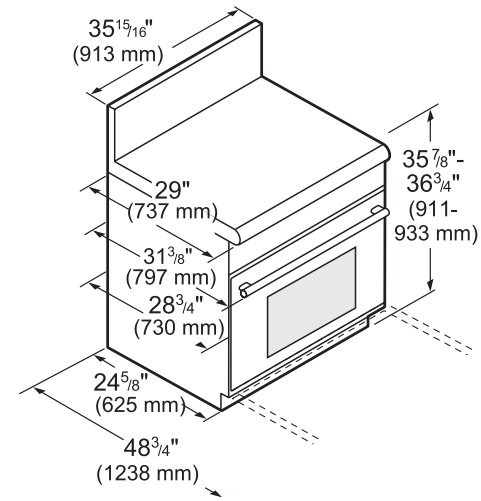

48-INCH RANGE DIMENSIONS

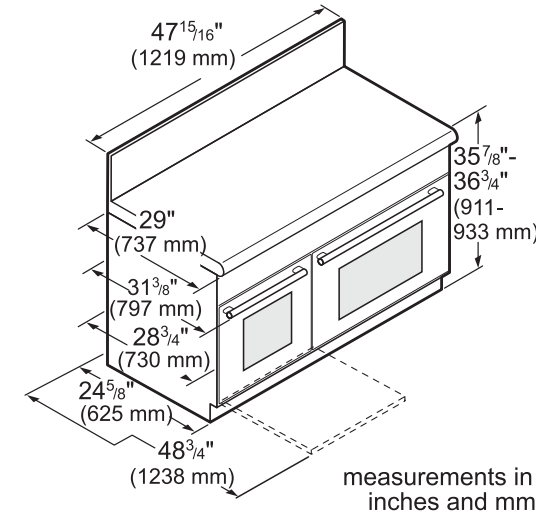

36-INCH RANGE CUTOUT DIMENSIONS

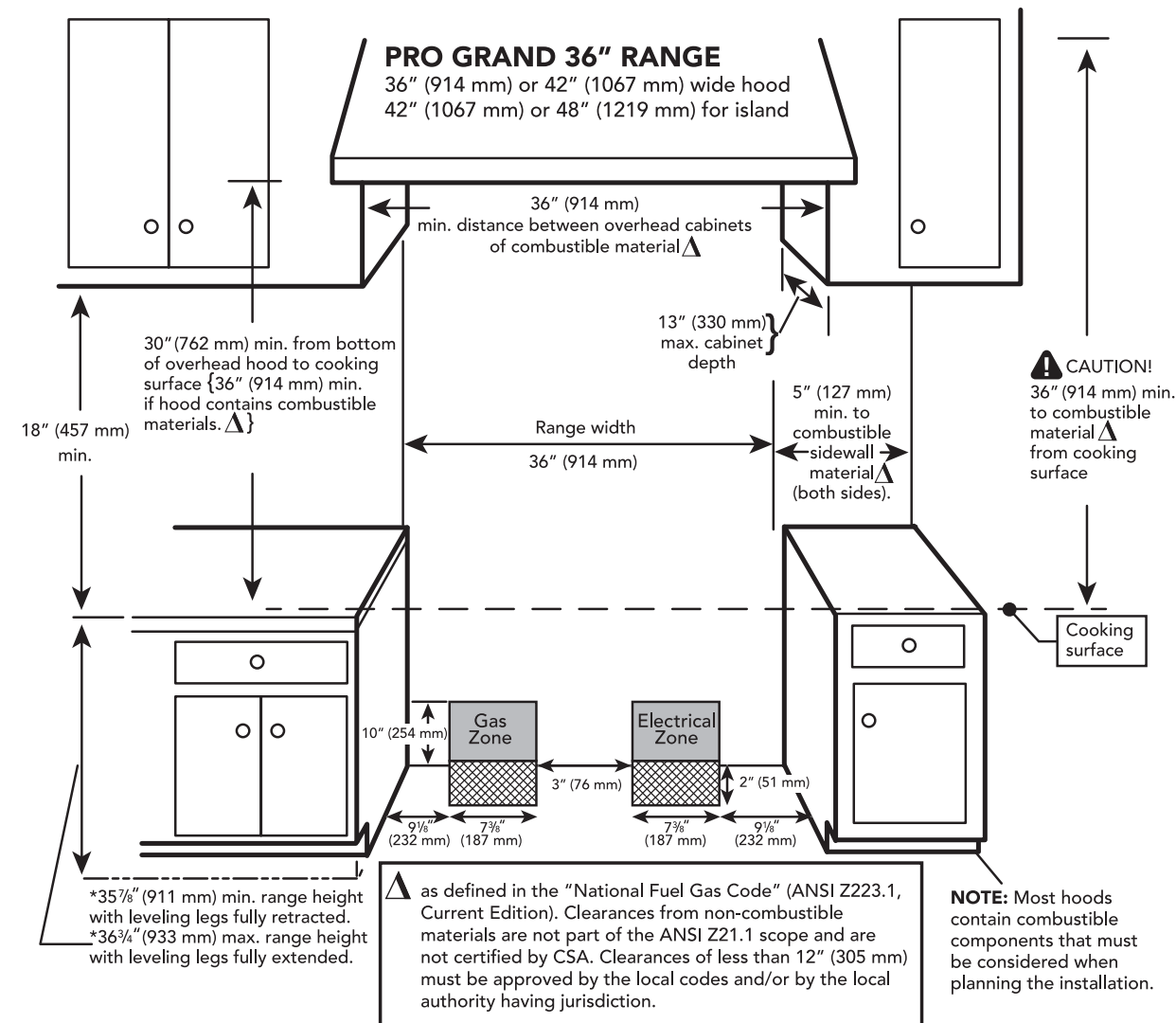

48-INCH RANGE CUTOUT DIMENSIONS

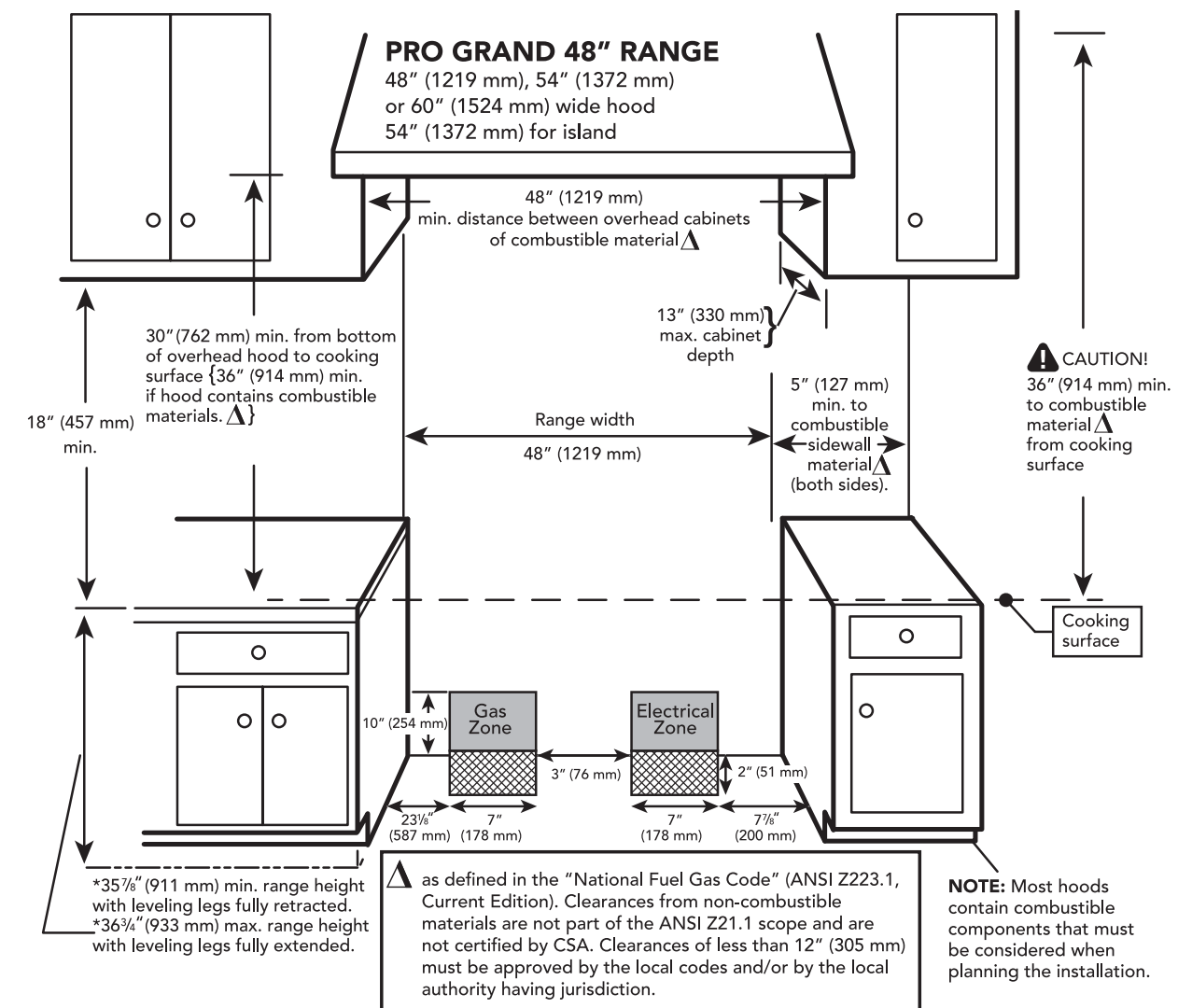

PRO GRAND® RANGES INSTALLATION

60-INCH RANGE DIMENSIONS

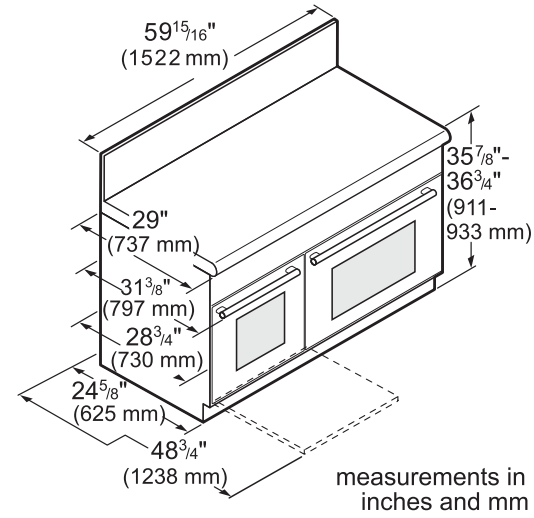

60-INCH RANGE CUTOUT DIMENSIONS

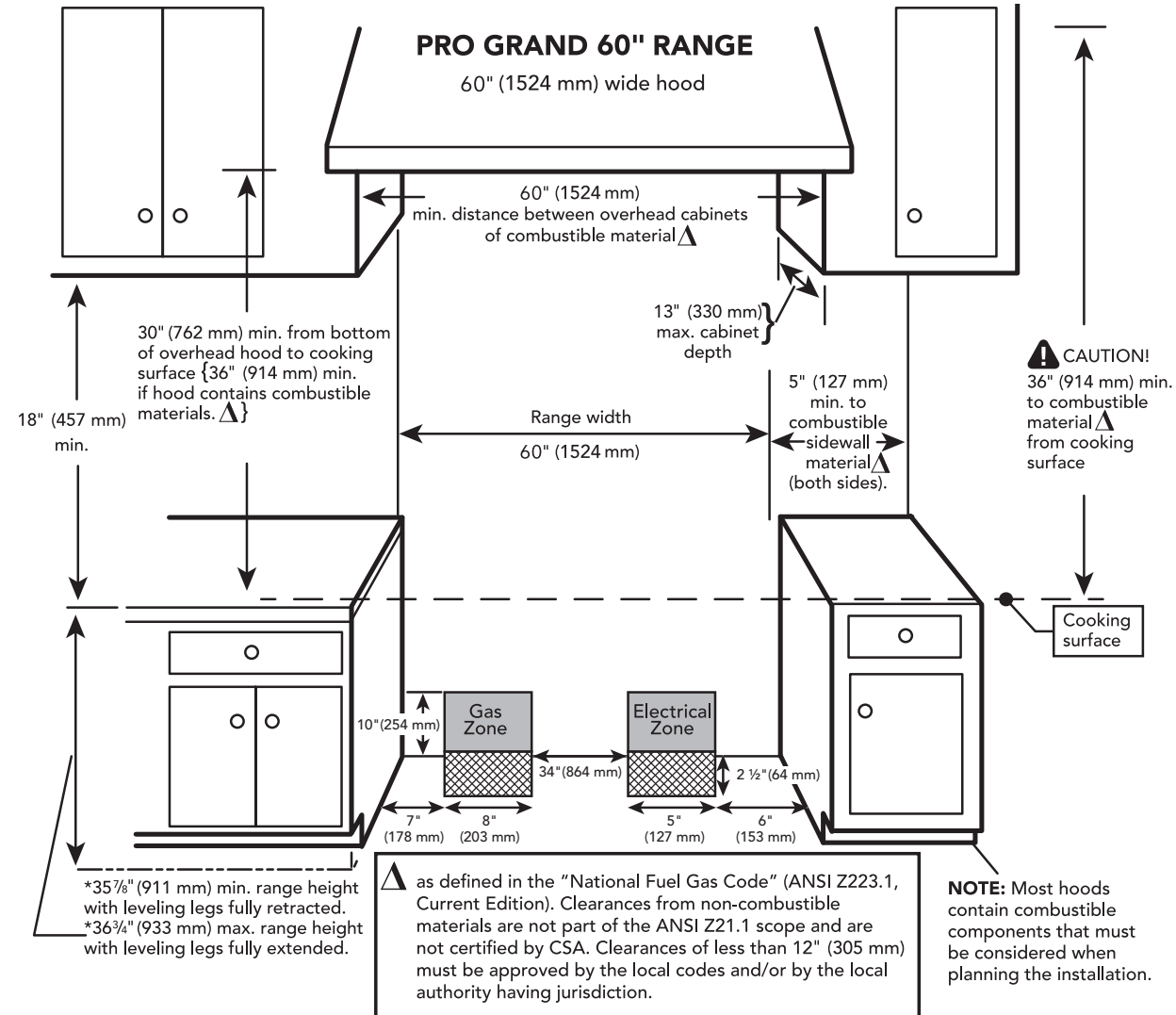

PRO GRAND® RANGES INSTALLATION

36-INCH, 48-INCH AND 60-INCH PRO GRAND RANGE DIMENSIONS AND CLEARANCE REQUIREMENTS WITH "LOW BACK"

NOTE: A 36-inch minimum clearance is required between the top of the cooking surface and the bottom of an unprotected cabinet. A 30-inch clearance can be used when the bottom of the wood or metal cabinet is protected by not less than 1/4 inch of a flame retardant material covered with not less than No. 28 MSG sheet steel, 0.015 inch (0.4 mm) thick stainless steel, 0.024 inch (0.6 mm) aluminum, or 0.020 inch (0.5 mm) thick copper.

Δ As defined in the "National Fuel Gas Code" (ANSI Z223.1, Current Edition). Clearances from non-combustible materials are not part of the ANSI Z21.1 scope and are not certified by CSA. Clearances of less than 12" (305 mm) must be approved by the local codes and/or by the local authority having jurisdiction.

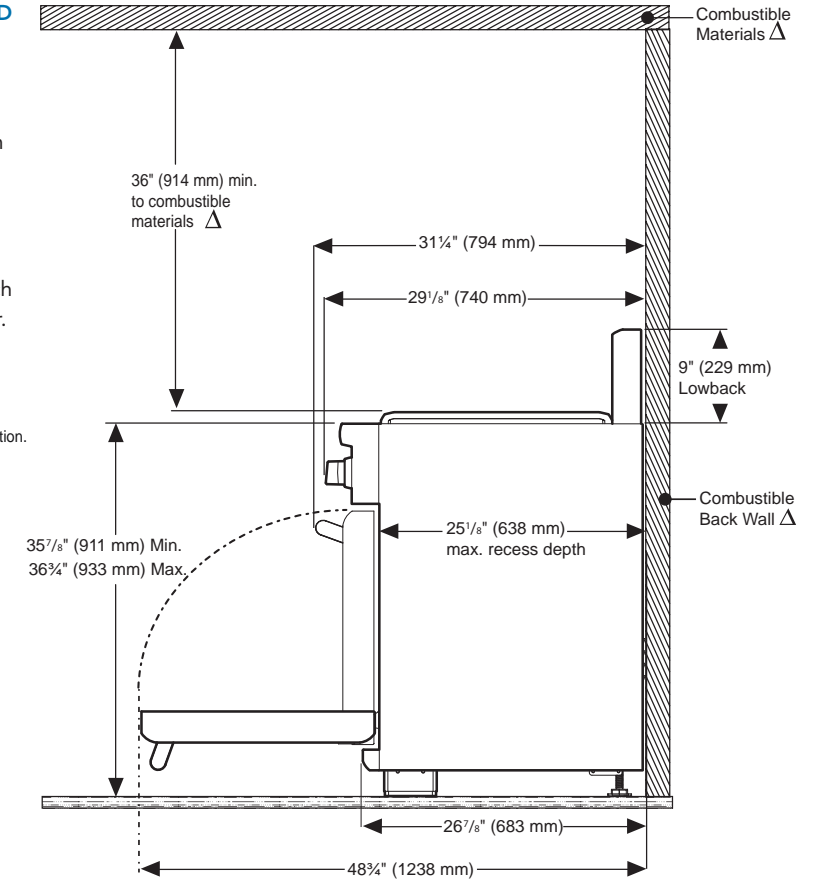

36-INCH, 48-INCH AND 60-INCH PRO GRAND RANGE DIMENSIONS AND CLEARANCE REQUIREMENTS WITH "FLUSH ISLAND TRIM"

Δ As defined in the "National Fuel Gas Code" (ANSI Z223.1, Current Edition). Clearances from non-combustible materials are not part of the ANSI Z21.1 scope and are not certified by CSA. Clearances of less than 12" (305 mm) must be approved by the local codes and/or by the local authority having jurisdiction.

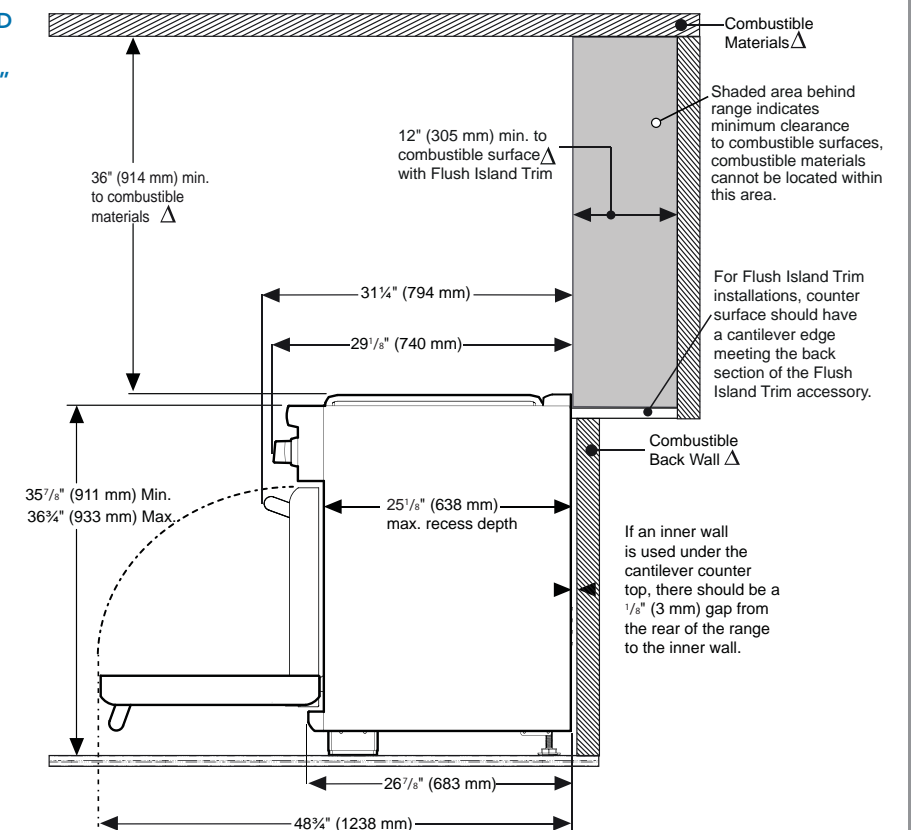



Thermador 

PRO HARMONY® RANGES

24-INCH DEPTH

Pro Harmony Ranges offer more of everything you expect from our high-performance, category-leading cooking appliances. This line of Truly Flush Mounted™, 24-inch standard cabinet depth ranges features innovations like our signature Star® Burner that delivers superior power and heat distribution and a QuickClean Base® for effortless cleaning. ExtraLow® burners provide precision simmering capabilities as low as 100°F so home chefs can pursue their culinary inspirations with absolute confidence.



Pro Harmony® Ranges COMMON FEATURES

The commanding presence and classic luxury of our Pro Harmony Ranges take the Thermador kitchen to new heights in performance, aesthetics and convenience. Every Pro Harmony Range features special ingredients to create the ultimate cooking experience.



★ EXTRALOW® SIMMER

Our ExtraLow feature provides the widest variety of temperature control of any simmer system. Cycling on and off, each Star Burner® can maintain temperatures as low as 100°, a must-have option for cooks who demand perfection when preparing delicate sauces, melted cheeses, or even sugary confections. Thermador Pro Harmony Ranges feature two ExtraLow burners.

★ QUICKCLEAN BASE®

The raised pedestal burner and porcelain maintop have been crafted for perfect integration and easy cleanup. A hand and sponge fit easily under each burner to wipe the surface clean and a teardrop emboss reduces food buildup near the base.

★ FASTEST TIME TO BOIL

Our Star® Burner's 18,000 BTU/hr of output and superior heat distribution boils water in a fraction of the time of a conventional range or cooktop and over 50% faster than leading competitors.

TELESCOPIC RACKS

Full Access® telescopic racks glide smoothly on ball bearings, allowing them to expand completely for safe, easy access to your meal. Plus, their robust construction safely supports the heaviest dishes while integrated easy-grip handles make them easy to use.

SINGLE FAN TECHNOLOGY

Our convection technology is so powerful that only one fan is needed. Convection keeps the temperature consistent throughout the cavity and allows for multi-rack cooking. Controlled airflow patterns optimize the transfer of heat so that food is heated evenly.

STAR-K CERTIFIED

Thermador Professional® Ranges are Star-K certified making it possible to use them on the Sabbath or the Holidays.



★ THERMADOR® EXCLUSIVE

A Star-Shaped Peg in a WORLD OF ROUND HOLES

★ OUR EXCLUSIVE, PATENTED STAR® BURNER

Lighting a heavenly fire under the status quo, the Star Burner is perhaps the single most iconic innovation from Thermador. But the star shape isn't just for show. Featured on all Thermador Professional® Ranges, the Star Burner delivers 56% more coverage with superior flame spread and a reduced cold spot for faster and more even heating across any size pan.

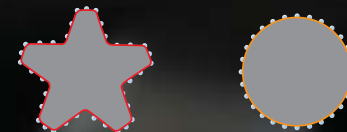

Star Burner: 50 ports / 16 3/4" perimeter

Conventional Burner: 28 ports / 10 3/4" perimeter





Pro Harmony® Ranges FEATURE HIGHLIGHTS

★ 5 BURNERS, 30-INCH FOOTPRINT, ZERO CLEARANCE

Pro Harmony ranges are now available with the luxury of 5 Star® burners in a convenient 30-inch footprint. The powerful burners fire up to 59,000 BTUs yet only require 300 CFM venting thanks to an innovative technology that reduces back wall temperatures by as much as 25%.* This allows you to install the range flush against a kitchen wall with zero clearance for complete design flexibility.

*When compared to professional ranges with traditional BTU output

TRULY FLUSH MOUNTED RANGE

Pro Harmony Ranges are designed to fit perfectly flush in standard 24-inch depth cabinets.

18,000 BTU/HR ON EVERY BURNER*

Delivers superior cooking flexibility by offering maximum heat output on every burner. Leading competitors offer only one or two powerful burners.

*Except models PRD305PH, PRG305PH, PRL305PH

UNMATCHED OVEN CAPACITY

36-inch models offer a 5.0 cubic feet capacity that accommodates even the largest meals effortlessly.



Features Available on Selected PRO HARMONY® RANGES

★ FASTEST SELF-CLEAN

In just 2 hours, the interior walls and rack supports become perfectly clean, thanks to the fastest self-cleaning cycle on the market.

INDOOR ELECTRIC PRO GRILL WITH CERAMIC BRIQUETTES

Our easy-to-clean, indoor grilling feature boasts industry-leading design, featuring ceramic briquettes and fusion coated grill plates that fully cover the heating elements to offer exceptional grilling performance with genuine smoky flavor while minimizing flare-ups. 2 heating zones let you control the front and back zones independently.

THIRD ELEMENT CONVECTION SYSTEM

Thermador® Dual-Fuel Ranges feature a True Convection system that directs heat to cook foods more evenly with gourmet results and 25% time savings.

12-INCH REMOVABLE GRIDDLE AND GRILL ACCESSORY

Our 12-inch non-stick, rust-proof cast-aluminum fusion coated surface griddle is thermostatically controlled to deliver consistent, even heating across the entire surface. It is also removable for easy cleaning or interchange it with our grill accessory.

Our non-stick, rust-proof cast-aluminum grill accessory (sold separately) features a fusion coated surface that is easy to clean and dishwasher-safe.



★ THERMADOR® EXCLUSIVE

PRO HARMONY® RANGES
OPTIONAL ACCESSORIES

	30-INCH DUAL-FUEL		36-INCH DUAL-FUEL			30-INCH GAS				36-INCH GAS					
	PRD304GHU	PRD305PH	PRD364GDHU	PRD364NLHU	PRD366GGHU	PRG304GH	PRL304GH	PRG305PH	PRL305PH	PRG366GH	PRL366GH	PRG364GDH	PRG364NLH	PRL364GDH	PRL364NLH
 PABRICKBKN Black Ceramic Briquettes with Basket				✓									✓		✓
 PA12GRILLN Pro Grill			✓									✓		✓	
 PA12LCVRN 12" Pro Grill Cover for Indoor Electric Grill				✓									✓		✓
 PA12CVRJ 12" Pro Grill / Griddle Cover			✓									✓		✓	
 PA30GLBH 9" Low Backguard	✓	✓				✓	✓	✓	✓						
 PA36GLBH 9" Low Backguard			✓	✓	✓					✓	✓	✓	✓	✓	✓
 PAGRIDDLEN Griddle for Indoor Electric Grill				✓									✓		✓
 PA12CHPBLK 12" Cutting Board	✓	✓	✓	✓	✓	✓	✓	✓	✓	✓	✓	✓	✓	✓	✓
 PAGRIDDLE Griddle	✓	✓	✓	✓	✓	✓	✓	✓	✓	✓	✓	✓	✓	✓	✓
 PWOKRINGHC Wok Ring	✓	✓	✓	✓	✓	✓	✓	✓	✓	✓	✓	✓	✓	✓	✓
 PAKNOBLUNH Blue Knob Pro Harmony Kit	✓	✓	✓	✓	✓	✓	✓	✓	✓	✓	✓	✓	✓	✓	✓
 PALPKITHN LP Conversion Kit	✓		✓	✓	✓										
 PALPKITHP LP Conversion Kit		✓													

PRO HARMONY® RANGES
OPTIONAL ACCESSORIES

	48-INCH DUAL-FUEL			48-INCH GAS			
	PRD486GDHU	PRD486NLHU	PRD484NCHU	PRG486GDH	PRG486NLH	PRL486GDH	PRL486NLH
 PABRICKBKN Black Ceramic Briquettes with Basket		✓	✓		✓		✓
 PA12GRILLN Pro Grill	✓			✓		✓	
 PA12LCVRN 12" Pro Grill Cover for Indoor Electric Grill		✓	✓		✓		✓
 PA12CVRJ 12" Pro Grill / Griddle Cover	✓			✓		✓	
 PA48GLBH 9" Low Backguard	✓	✓	✓	✓	✓	✓	✓
 PAGRIDDLEN Griddle for Indoor Electric Grill		✓	✓		✓		✓
 PA12CHPBLK 12" Cutting Board	✓	✓	✓	✓	✓	✓	✓
 PAGRIDDLE Griddle	✓	✓	✓	✓	✓	✓	✓
 PWOKRINGHC Wok Ring	✓	✓	✓	✓	✓	✓	✓
 PAKNOBLUNH Blue Knob Pro Harmony Kit	✓	✓	✓	✓	✓	✓	✓
 PALPKITHN LP Conversion Kit	✓	✓	✓				

PRD304GHU
30-INCH DUAL-FUEL PRO HARMONY® RANGE
 PROFESSIONAL SERIES, STANDARD-DEPTH, PORCELAIN COOKTOP SURFACE



GENERAL PROPERTIES	
Oven Capacity	4.4 cu. ft.
Cooking Modes - Main / Large Cavity	
Bake, Convection Bake, Broil, Convection Broil, Self Clean, Extended Bake	
Cooking Modes - Small Cavity	N/A
Programs	Sabbath Function
Cleaning Type	Self Clean
Type of Grate	Continuous Cast Iron
Controls	Metal Knobs
Sealed Burners	Yes

OVEN PERFORMANCE	
Bake Power	2,000 W
Broil Power	4,000 W
Convection Power	2,750 W

BURNER PERFORMANCE	
Total Number of Cooktop Burners	4
Power of Front Left Burner BTU	18,000 and XLO (NG)
Power of Back Left Burner BTU	18,000 and XLO (NG)
Power of Back Center Burner BTU	N/A
Power of Front Center Burner BTU	N/A
Power of Center 12" Electric Griddle (W)	N/A
Power of Center 12" Electric Grill (W)	N/A
Power of Far Right 12" Electric Griddle (W)	N/A
Power of Back Right Burner BTU	18,000 (NG)
Power of Front Right Burner BTU	18,000 (NG)

DIMENSIONS & WEIGHT	
Overall Appliance Dimensions (HxWxD) (in)	35 7/8"-36 3/4" x 29 15/16" x 24 3/4"
Required Cutout Size (HxWxD) (in)	35 7/8"-36 3/4" x 30" x 24"
Adjustable Range Height (in.)	7/8"
Net Weight (lbs)	377 lbs

ACCESSORIES (INCLUDED)	
1 X Island Trim, 1 X Full Access Telescopic Rack, 2 X Standard Racks, 1 X Broiler Pan	

WARRANTY	
Limited Warranty, Entire Appliance, Parts and Labor	2 Year

FEATURES & BENEFITS

- ★ - Exclusive, patented Star® Burner—most even heating, unsurpassed flame coverage
- ★ - QuickClean Base® designed for easy surface cleaning
- ★ - Precision simmering capabilities as low as 100°F (375 BTU) with 2 ExtraLow® Simmer burners
- ★ - Superfast 2-hour self-clean mode—fastest in the industry
 - Professional style, continuous cast iron grates

TECHNICAL DETAILS

Circuit Breaker (A)	35 A
Volts (V)	240 / 208 V
Frequency (Hz)	60 Hz
Plug Type	No Plug
Power Cord Length (in)	Purchase Separately
Energy Source	Gas and Electric
Gas Type	Natural Gas 15 mbar (USA)
Alternative Gas Type	Liquid Gas 27.5 mbar (USA)

See page 62 for optional accessories.

PRD305PH
30-INCH DUAL-FUEL PRO HARMONY® RANGE
 PROFESSIONAL SERIES, STANDARD-DEPTH, PORCELAIN COOKTOP SURFACE



GENERAL PROPERTIES	
Oven Capacity	4.4 cu. ft.
Cooking Modes - Main / Large Cavity	
Bake, Convection Bake, Broil, Convection Broil, Self Clean, Extended Bake	
Cooking Modes - Small Cavity	N/A
Programs	Sabbath Function
Cleaning Type	Self Clean
Type of Grate	Continuous Cast Iron
Controls	Metal Knobs
Sealed Burners	Yes

OVEN PERFORMANCE	
Bake Power	2,000 W
Broil Power	4,000 W
Convection Power	2,750 W

BURNER PERFORMANCE	
Total Number of Cooktop Burners	5
Power of Front Left Burner BTU	10,000 (NG)
Power of Back Left Burner BTU	8,000 and XLO (NG)
Power of Back Center Burner BTU	15,000 (NG)
Power of Front Center Burner BTU	N/A
Power of Center 12" Electric Griddle (W)	N/A
Power of Center 12" Electric Grill (W)	N/A
Power of Far Right 12" Electric Griddle (W)	N/A
Power of Back Right Burner BTU	8,000 (NG)
Power of Front Right Burner BTU	18,000 and XLO (NG)

DIMENSIONS & WEIGHT	
Overall Appliance Dimensions (HxWxD) (in)	35 7/8"-36 3/4" x 29 15/16" x 24 3/4"
Required Cutout Size (HxWxD) (in)	35 7/8"-36 3/4" x 30" x 24"
Adjustable Range Height (in.)	7/8"
Net Weight (lbs)	340 lbs

ACCESSORIES (INCLUDED)	
1 X Island Trim, 1 X Full Access Telescopic Rack, 2 X Standard Racks, 1 X Broiler Pan	

WARRANTY	
Limited Warranty, Entire Appliance, Parts and Labor	2 Year

FEATURES & BENEFITS

- ★ - Exclusive, patented Star® Burner—most even heating, unsurpassed flame coverage
- ★ - QuickClean Base® designed for easy surface cleaning
- ★ - Precision simmering capabilities as low as 100°F (375 BTU) with 2 ExtraLow® Simmer burners
- ★ - Superfast 2-hour self-clean mode—fastest in the industry
 - Professional style, continuous cast iron grates

TECHNICAL DETAILS

Circuit Breaker (A)	35 A
Volts (V)	240 / 208 V
Frequency (Hz)	60 Hz
Plug Type	No Plug
Power Cord Length (in)	Purchase Separately
Energy Source	Gas and Electric
Gas Type	Natural Gas 15 mbar (USA)
Alternative Gas Type	Liquid Gas 27.5 mbar (USA)

See page 62 for optional accessories.

PRD364GDHU

36-INCH DUAL-FUEL PRO HARMONY® RANGE WITH GRIDDLE

PROFESSIONAL SERIES, STANDARD-DEPTH, PORCELAIN COOKTOP SURFACE



FEATURES & BENEFITS

- ★ - Exclusive, patented Star® Burner—most even heating, unsurpassed flame coverage
- ★ - QuickClean Base® designed for easy surface cleaning
- ★ - Precision simmering capabilities as low as 100°F (375 BTU) with 2 ExtraLow® Simmer burners
- ★ - Superfast 2-hour self-clean mode—fastest in the industry
 - Professional style, continuous cast iron grates

TECHNICAL DETAILS

Circuit Breaker (A)	35 A
Volts (V)	240 / 208 V
Frequency (Hz)	60 Hz
Plug Type	No Plug
Power Cord Length (in)	Purchase Separately
Energy Source	Gas and Electric
Gas Type	Natural Gas 15 mbar (USA)
Alternative Gas Type	Liquid Gas 27.5 mbar (USA)

GENERAL PROPERTIES

Oven Capacity	4.8 cu. ft.
Cooking Modes - Main / Large Cavity	
Bake, Convection Bake, Broil, Convection Broil, Self Clean, Extended Bake	
Cooking Modes - Small Cavity	N/A
Programs	Sabbath Function
Cleaning Type	Self Clean
Type of Grate	Continuous Cast Iron
Controls	Metal Knobs
Sealed Burners	Yes

OVEN PERFORMANCE

Bake Power	2,000 W
Broil Power	4,000 W
Convection Power	2,750 W

BURNER PERFORMANCE

Total Number of Cooktop Burners	4 + Griddle
Power of Front Left Burner BTU	18,000 and XLO (NG)
Power of Back Left Burner BTU	18,000 and XLO (NG)
Power of Back Center Burner BTU	N/A
Power of Front Center Burner BTU	N/A
Power of Center 12" Electric Griddle (W)	1,630 W
Power of Center 12" Electric Grill (W)	N/A
Power of Far Right 12" Electric Griddle (W)	N/A
Power of Back Right Burner BTU	18,000 (NG)
Power of Front Right Burner BTU	18,000 (NG)

DIMENSIONS & WEIGHT

Overall Appliance Dimensions (HxWxD) (in)	35 7/8"-36 3/4" x 35 15/16" x 24 3/4"
Required Cutout Size (HxWxD) (in)	35 7/8"-36 3/4" x 36" x 24"
Adjustable Range Height (in.)	7/8"
Net Weight (lbs)	395 lbs

ACCESSORIES (INCLUDED)

1 X Island Trim, 3 X Full Access Telescopic Racks, 1 X Broiler Pan

WARRANTY

Limited Warranty, Entire Appliance, Parts and Labor	2 Year
---	--------

Thermador ★

PRD364NLHU

36-INCH DUAL-FUEL PRO HARMONY® RANGE WITH GRILL

PROFESSIONAL SERIES, STANDARD-DEPTH, PORCELAIN COOKTOP SURFACE



FEATURES & BENEFITS

- ★ - Exclusive, patented Star® Burner—most even heating, unsurpassed flame coverage
- ★ - QuickClean Base® designed for easy surface cleaning
- ★ - Precision simmering capabilities as low as 100°F (375 BTU) with 2 ExtraLow® Simmer burners
- ★ - Superfast 2-hour self-clean mode—fastest in the industry
 - Professional style, continuous cast iron grates

TECHNICAL DETAILS

Circuit Breaker (A)	40 A
Volts (V)	240 / 208 V
Frequency (Hz)	60 Hz
Plug Type	No Plug
Power Cord Length (in)	Purchase Separately
Energy Source	Gas and Electric
Gas Type	Natural Gas 15 mbar (USA)
Alternative Gas Type	Liquid Gas 27.5 mbar (USA)

GENERAL PROPERTIES

Oven Capacity	4.8 cu. ft.
Cooking Modes - Main / Large Cavity	
Bake, Convection Bake, Broil, Convection Broil, Self Clean, Extended Bake	
Cooking Modes - Small Cavity	N/A
Programs	Sabbath Function
Cleaning Type	Self Clean
Type of Grate	Continuous Cast Iron
Controls	Metal Knobs
Sealed Burners	Yes

OVEN PERFORMANCE

Bake Power	2,000 W
Broil Power	4,000 W
Convection Power	2,750 W

BURNER PERFORMANCE

Total Number of Cooktop Burners	4 + Grill
Power of Front Left Burner BTU	18,000 and XLO (NG)
Power of Back Left Burner BTU	18,000 and XLO (NG)
Power of Back Center Burner BTU	N/A
Power of Front Center Burner BTU	N/A
Power of Center 12" Electric Griddle (W)	N/A
Power of Center 12" Electric Grill (W)	2,000 W
Power of Far Right 12" Electric Griddle (W)	N/A
Power of Back Right Burner BTU	18,000 (NG)
Power of Front Right Burner BTU	18,000 (NG)

DIMENSIONS & WEIGHT

Overall Appliance Dimensions (HxWxD) (in)	35 7/8"-36 3/4" x 35 15/16" x 24 3/4"
Required Cutout Size (HxWxD) (in)	35 7/8"-36 3/4" x 36" x 24"
Adjustable Range Height (in.)	7/8"
Net Weight (lbs)	374 lbs

ACCESSORIES (INCLUDED)

1 X Island Trim, 3 X Full Access Telescopic Racks, 1 X Broiler Pan

WARRANTY

Limited Warranty, Entire Appliance, Parts and Labor	2 Year
---	--------

Thermador ★

See page 62 for optional accessories.

★ THERMADOR® EXCLUSIVE

★ THERMADOR® EXCLUSIVE

See page 62 for optional accessories.

PRD366GHU
36-INCH DUAL-FUEL PRO HARMONY® RANGE
 PROFESSIONAL SERIES, STANDARD-DEPTH, PORCELAIN COOKTOP SURFACE



GENERAL PROPERTIES	
Oven Capacity	4.8 cu. ft.
Cooking Modes - Main / Large Cavity	
Bake, Convection Bake, Broil, Convection Broil, Self Clean, Extended Bake	
Cooking Modes - Small Cavity	N/A
Programs	Sabbath Function
Cleaning Type	Self Clean
Type of Grate	Continuous Cast Iron
Controls	Metal Knobs
Sealed Burners	Yes

OVEN PERFORMANCE	
Bake Power	2,000 W
Broil Power	4,000 W
Convection Power	2,750 W

BURNER PERFORMANCE	
Total Number of Cooktop Burners	6
Power of Front Left Burner BTU	18,000 and XLO (NG)
Power of Back Left Burner BTU	18,000 and XLO (NG)
Power of Back Center Burner BTU	18,000 (NG)
Power of Front Center Burner BTU	18,000 (NG)
Power of Center 12" Electric Griddle (W)	N/A
Power of Center 12" Electric Grill (W)	N/A
Power of Far Right 12" Electric Griddle (W)	N/A
Power of Back Right Burner BTU	18,000 (NG)
Power of Front Right Burner BTU	18,000 (NG)

DIMENSIONS & WEIGHT	
Overall Appliance Dimensions (HxWxD) (in)	35 7/8"–36 3/4" x 35 15/16" x 24 3/4"
Required Cutout Size (HxWxD) (in)	35 7/8"–36 3/4" x 36" x 24"
Adjustable Range Height (in.)	7/8"
Net Weight (lbs)	425 lbs

ACCESSORIES (INCLUDED)	
1 X Island Trim, 3 X Full Access Telescopic Rack, 1 X Broiler Pan	

WARRANTY	
Limited Warranty, Entire Appliance, Parts and Labor	2 Year

FEATURES & BENEFITS

- ★ - Exclusive, patented Star® Burner—most even heating, unsurpassed flame coverage
- ★ - QuickClean Base® designed for easy surface cleaning
- ★ - Precision simmering capabilities as low as 100°F (375 BTU) with 2 ExtraLow® Simmer burners
- ★ - Superfast 2-hour self-clean mode—fastest in the industry
 - Professional style, continuous cast iron grates

TECHNICAL DETAILS

Circuit Breaker (A)	35 A
Volts (V)	240 / 208 V
Frequency (Hz)	60 Hz
Plug Type	No Plug
Power Cord Length (in)	Purchase Separately
Energy Source	Gas and Electric
Gas Type	Natural Gas 15 mbar (USA)
Alternative Gas Type	Liquid Gas 27.5 mbar (USA)

See page 62 for optional accessories.

PRD486GDHU
48-INCH DUAL-FUEL PRO HARMONY® RANGE WITH GRIDDLE
 PROFESSIONAL SERIES, STANDARD-DEPTH, PORCELAIN COOKTOP SURFACE



GENERAL PROPERTIES	
Oven Capacity	4.4 / 2.2 cu. ft.
Cooking Modes - Main / Large Cavity	
Bake, Convection Bake, Broil, Convection Broil, Self Clean, Extended Bake	
Cooking Modes - Small Cavity	
Bake, Broil, Self Clean, Warm, Proof	
Programs	Sabbath Function (Main)
Cleaning Type	Self Clean (Both)
Type of Grate	Continuous Cast Iron
Controls	Metal Knobs
Sealed Burners	Yes

OVEN PERFORMANCE	
Bake Power	2,000 W (Lg) / 1,400 W (Sm)
Broil Power	4,000 W (Lg) / 2,600 W (Sm)
Convection Power	2,750 W Ring (Lg)

BURNER PERFORMANCE	
Total Number of Cooktop Burners	6 + Griddle
Power of Front Left Burner BTU	18,000 and XLO (NG)
Power of Back Left Burner BTU	18,000 and XLO (NG)
Power of Back Center Burner BTU	18,000 (NG)
Power of Front Center Burner BTU	18,000 (NG)
Power of Center 12" Electric Griddle (W)	1,630 W
Power of Center 12" Electric Grill (W)	N/A
Power of Far Right 12" Electric Griddle (W)	N/A
Power of Back Right Burner BTU	18,000 (NG)
Power of Front Right Burner BTU	18,000 (NG)

DIMENSIONS & WEIGHT	
Overall Appliance Dimensions (HxWxD) (in)	35 7/8"–36 3/4" x 47 7/8" x 24 3/4"
Required Cutout Size (HxWxD) (in)	35 7/8"–36 3/4" x 48" x 24"
Adjustable Range Height (in.)	7/8"
Net Weight (lbs)	560 lbs

ACCESSORIES (INCLUDED)	
1 X Island Trim, 3 X Full Access Telescopic Racks, 2 X Telescopic Rack - Small, 1 X Broiler Pan	

WARRANTY	
Limited Warranty, Entire Appliance, Parts and Labor	2 Year

FEATURES & BENEFITS

- ★ - Exclusive, patented Star® Burner—most even heating, unsurpassed flame coverage
- ★ - QuickClean Base® designed for easy surface cleaning
- ★ - Precision simmering capabilities as low as 100°F (375 BTU) with 2 ExtraLow® Simmer burners
- ★ - Cleans both ovens simultaneously in just 2 hours
 - Professional style, continuous cast iron grates

TECHNICAL DETAILS

Circuit Breaker (A)	50 A
Volts (V)	240 / 208 V
Frequency (Hz)	60 Hz
Plug Type	No Plug
Power Cord Length (in)	Purchase Separately
Energy Source	Gas and Electric
Gas Type	Natural Gas 15 mbar (USA)
Alternative Gas Type	Liquid Gas 27.5 mbar (USA)

See page 62 for optional accessories.

PRD486NLHU
48-INCH DUAL-FUEL PRO HARMONY® RANGE WITH GRILL
 PROFESSIONAL SERIES, STANDARD-DEPTH, PORCELAIN COOKTOP SURFACE



GENERAL PROPERTIES	
Oven Capacity	4.4 / 2.2 cu. ft.
Cooking Modes - Main / Large Cavity	
Bake, Convection Bake, Broil, Convection Broil, Self Clean, Extended Bake	
Cooking Modes - Small Cavity	
Bake, Broil, Self Clean, Warm, Proof	
Programs	Sabbath Function (Main)
Cleaning Type	Self Clean (Both)
Type of Grate	Continuous Cast Iron
Controls	Metal Knobs
Sealed Burners	Yes

OVEN PERFORMANCE	
Bake Power	2,000 W (Lg) / 1,400 W (Sm)
Broil Power	4,000 W (Lg) / 2,600 W (Sm)
Convection Power	2,750 W Ring (Lg)

BURNER PERFORMANCE	
Total Number of Cooktop Burners	6 + Grill
Power of Front Left Burner BTU	18,000 and XLO (NG)
Power of Back Left Burner BTU	18,000 and XLO (NG)
Power of Back Center Burner BTU	18,000 (NG)
Power of Front Center Burner BTU	18,000 (NG)
Power of Center 12" Electric Griddle (W)	N/A
Power of Center 12" Electric Grill (W)	2,000 W
Power of Far Right 12" Electric Griddle (W)	N/A
Power of Back Right Burner BTU	18,000 (NG)
Power of Front Right Burner BTU	18,000 (NG)

DIMENSIONS & WEIGHT	
Overall Appliance Dimensions (HxWxD) (in)	35 7/8"–36 3/4" x 47 7/8" x 24 3/4"
Required Cutout Size (HxWxD) (in)	35 7/8"–36 3/4" x 48" x 24"
Adjustable Range Height (in.)	7/8"
Net Weight (lbs)	537 lbs

ACCESSORIES (INCLUDED)
 1 X Island Trim, 3 X Full Access Telescopic Racks, 2 X Telescopic Rack - Small, 1 X Broiler Pan

WARRANTY	
Limited Warranty, Entire Appliance, Parts and Labor	2 Year

FEATURES & BENEFITS

- ★ - Exclusive, patented Star® Burner—most even heating, unsurpassed flame coverage
- ★ - QuickClean Base® designed for easy surface cleaning
- ★ - Precision simmering capabilities as low as 100°F (375 BTU) with 2 ExtraLow® Simmer burners
- ★ - Cleans both ovens simultaneously in just 2 hours
- Professional style, continuous cast iron grates

TECHNICAL DETAILS

Circuit Breaker (A)	50 A
Volts (V)	240 / 208 V
Frequency (Hz)	60 Hz
Plug Type	No Plug
Power Cord Length (in)	Purchase Separately
Energy Source	Gas and Electric
Gas Type	Natural Gas 15 mbar (USA)
Alternative Gas Type	Liquid Gas 27.5 mbar (USA)

See page 62 for optional accessories.

PRD484NCHU
48-INCH DUAL-FUEL PRO HARMONY® RANGE WITH GRIDDLE AND GRILL
 PROFESSIONAL SERIES, STANDARD-DEPTH, PORCELAIN COOKTOP SURFACE



GENERAL PROPERTIES	
Oven Capacity	4.4 / 2.2 cu. ft.
Cooking Modes - Main / Large Cavity	
Bake, Convection Bake, Broil, Convection Broil, Self Clean, Extended Bake	
Cooking Modes - Small Cavity	
Bake, Broil, Self Clean, Warm, Proof	
Programs	Sabbath Function (Main)
Cleaning Type	Self Clean (Both)
Type of Grate	Continuous Cast Iron
Controls	Metal Knobs
Sealed Burners	Yes

OVEN PERFORMANCE	
Bake Power	2,000 W (Lg) / 1,400 W (Sm)
Broil Power	4,000 W (Lg) / 2,600 W (Sm)
Convection Power	2,750 W Ring (Lg)

BURNER PERFORMANCE	
Total Number of Cooktop Burners	4 + Griddle and Grill
Power of Front Left Burner BTU	18,000 and XLO (NG)
Power of Back Left Burner BTU	18,000 and XLO (NG)
Power of Back Center Burner BTU	18,000 (NG)
Power of Front Center Burner BTU	18,000 (NG)
Power of Center 12" Electric Griddle (W)	N/A
Power of Center 12" Electric Grill (W)	2,000 W
Power of Far Right 12" Electric Griddle (W)	1,630 W
Power of Back Right Burner BTU	N/A
Power of Front Right Burner BTU	N/A

DIMENSIONS & WEIGHT	
Overall Appliance Dimensions (HxWxD) (in)	35 7/8"–36 3/4" x 47 7/8" x 24 3/4"
Required Cutout Size (HxWxD) (in)	35 7/8"–36 3/4" x 48" x 24"
Adjustable Range Height (in.)	7/8"
Net Weight (lbs)	537 lbs

ACCESSORIES (INCLUDED)
 1 X Island Trim, 3 X Full Access Telescopic Racks, 2 X Telescopic Rack - Small, 1 X Broiler Pan

WARRANTY	
Limited Warranty, Entire Appliance, Parts and Labor	2 Year

FEATURES & BENEFITS

- ★ - Exclusive, patented Star® Burner—most even heating, unsurpassed flame coverage
- ★ - QuickClean Base® designed for easy surface cleaning
- ★ - Precision simmering capabilities as low as 100°F (375 BTU) with 2 ExtraLow® Simmer burners
- ★ - Cleans both ovens simultaneously in just 2 hours
- Professional style, continuous cast iron grates

TECHNICAL DETAILS

Circuit Breaker (A)	50 A
Volts (V)	240 / 208 V
Frequency (Hz)	60 Hz
Plug Type	No Plug
Power Cord Length (in)	Purchase Separately
Energy Source	Gas and Electric
Gas Type	Natural Gas 15 mbar (USA)
Alternative Gas Type	Liquid Gas 27.5 mbar (USA)

See page 62 for optional accessories.

PRG304GH
30-INCH GAS PRO HARMONY® RANGE
 PROFESSIONAL SERIES, STANDARD-DEPTH, PORCELAIN COOKTOP SURFACE



Also Available:
 PRL304GH - LP

FEATURES & BENEFITS

- ★ - Exclusive, patented Star® Burner—most even heating, unsurpassed flame coverage
- ★ - QuickClean Base® designed for easy surface cleaning
- ★ - Precision simmering capabilities as low as 100°F (375 BTU) with 2 ExtraLow® Simmer burners
 - Professional style, continuous cast iron grates
 - Truly Flush Mounted™, 24" standard cabinet depth

TECHNICAL DETAILS

Circuit Breaker (A)	15 A
Volts (V)	120 V
Frequency (Hz)	60 Hz
Plug Type	120V-3 Prong
Power Cord Length (in)	72"
Energy Source	Gas
Gas Type	Natural Gas 15 mbar (USA)
Alternative Gas Type	Liquid Gas 27.5 mbar (USA)

GENERAL PROPERTIES

Oven Capacity	4.4 cu. ft.
Cooking Modes - Main / Large Cavity	
Bake, Convection Bake, Broil, Extended Bake	
Cooking Modes - Small Cavity	N/A
Programs	Sabbath Function
Cleaning Type	N/A
Type of Grate	Continuous Cast Iron
Controls	Metal Knobs
Sealed Burners	Yes

OVEN PERFORMANCE

Bake Power	23,500 BTU (NG)
Broil Power	24,000 BTU (NG)
Convection Power	N/A

BURNER PERFORMANCE

Total Number of Cooktop Burners	4
Power of Front Left Burner BTU	18,000 and XLO (NG)
Power of Back Left Burner BTU	18,000 and XLO (NG)
Power of Back Center Burner BTU	N/A
Power of Front Center Burner BTU	N/A
Power of Center 12" Electric Griddle (W)	N/A
Power of Center 12" Electric Grill (W)	N/A
Power of Far Right 12" Electric Griddle (W)	N/A
Power of Back Right Burner BTU	18,000 (NG)
Power of Front Right Burner BTU	18,000 (NG)

DIMENSIONS & WEIGHT

Overall Appliance Dimensions (HxWxD) (in)	35 7/8"-36 3/4" x 29 15/16" x 24 3/4"
Required Cutout Size (HxWxD) (in)	35 7/8"-36 3/4" x 30" x 24"
Adjustable Range Height (in.)	7/8"
Net Weight (lbs)	372 lbs

ACCESSORIES (INCLUDED)

1 X Island Trim, 1 X Full Access Telescopic Rack, 2 X Standard Racks, 1 X Broiler Pan

WARRANTY

Limited Warranty, Entire Appliance, Parts and Labor	2 Year
---	--------

See page 62 for optional accessories.

PRL304GH
30-INCH GAS PRO HARMONY® RANGE (LP)
 PROFESSIONAL SERIES, STANDARD-DEPTH, PORCELAIN COOKTOP SURFACE



Also Available:
 PRG304GH - Natural Gas

FEATURES & BENEFITS

- ★ - Exclusive, patented Star® Burner—most even heating, unsurpassed flame coverage
- ★ - QuickClean Base® designed for easy surface cleaning
- ★ - Precision simmering capabilities as low as 100°F (375 BTU) with 2 ExtraLow® Simmer burners
 - Professional style, continuous cast iron grates
 - Truly Flush Mounted™, 24" standard cabinet depth

TECHNICAL DETAILS

Circuit Breaker (A)	15 A
Volts (V)	120 V
Frequency (Hz)	60 Hz
Plug Type	120V-3 Prong
Power Cord Length (in)	72"
Energy Source	Gas
Gas Type	Liquid Gas 27.5 mbar (USA)
Alternative Gas Type	Natural Gas 15 mbar (USA)

GENERAL PROPERTIES

Oven Capacity	4.4 cu. ft.
Cooking Modes - Main / Large Cavity	
Bake, Convection Bake, Broil, Extended Bake	
Cooking Modes - Small Cavity	N/A
Programs	Sabbath Function
Cleaning Type	N/A
Type of Grate	Continuous Cast Iron
Controls	Metal Knobs
Sealed Burners	Yes

OVEN PERFORMANCE

Bake Power	22,600 BTU (LP)
Broil Power	22,000 BTU (LP)
Convection Power	N/A

BURNER PERFORMANCE

Total Number of Cooktop Burners	4
Power of Front Left Burner BTU	15,000 and XLO (LP)
Power of Back Left Burner BTU	15,000 and XLO (LP)
Power of Back Center Burner BTU	N/A
Power of Front Center Burner BTU	N/A
Power of Center 12" Electric Griddle (W)	N/A
Power of Center 12" Electric Grill (W)	N/A
Power of Far Right 12" Electric Griddle (W)	N/A
Power of Back Right Burner BTU	15,000 (LP)
Power of Front Right Burner BTU	15,000 (LP)

DIMENSIONS & WEIGHT

Overall Appliance Dimensions (HxWxD) (in)	35 7/8"-36 3/4" x 29 15/16" x 24 3/4"
Required Cutout Size (HxWxD) (in)	35 7/8"-36 3/4" x 30" x 24"
Adjustable Range Height (in.)	7/8"
Net Weight (lbs)	372 lbs

ACCESSORIES (INCLUDED)

1 X Island Trim, 1 X Full Access Telescopic Rack, 2 X Standard Racks, 1 X Broiler Pan

WARRANTY

Limited Warranty, Entire Appliance, Parts and Labor	2 Year
---	--------

See page 62 for optional accessories.

PRG305PH
30-INCH GAS PRO HARMONY® RANGE
 PROFESSIONAL SERIES, STANDARD-DEPTH, PORCELAIN COOKTOP SURFACE



GENERAL PROPERTIES	
Oven Capacity	4.4 cu. ft.
Cooking Modes - Main / Large Cavity	
Bake, Convection Bake, Broil, Extended Bake	
Cooking Modes - Small Cavity	N/A
Programs	Sabbath Function
Cleaning Type	N/A
Type of Grate	Continuous Cast Iron
Controls	Metal Knobs
Sealed Burners	Yes

OVEN PERFORMANCE	
Bake Power	23,500 BTU (NG)
Broil Power	24,000 BTU (NG)
Convection Power	N/A

BURNER PERFORMANCE	
Total Number of Cooktop Burners	5
Power of Front Left Burner BTU	10,000 (NG)
Power of Back Left Burner BTU	8,000 and XLO (NG)
Power of Back Center Burner BTU	15,000 (NG)
Power of Front Center Burner BTU	N/A
Power of Center 12" Electric Griddle (W)	N/A
Power of Center 12" Electric Grill (W)	N/A
Power of Far Right 12" Electric Griddle (W)	N/A
Power of Back Right Burner BTU	8,000 (NG)
Power of Front Right Burner BTU	18,000 and XLO (NG)

DIMENSIONS & WEIGHT	
Overall Appliance Dimensions (HxWxD) (in)	35 7/8"-36 3/4" x 29 15/16" x 24 3/4"
Required Cutout Size (HxWxD) (in)	35 7/8"-36 3/4" x 30" x 24"
Adjustable Range Height (in.)	7/8"
Net Weight (lbs)	336 lbs

ACCESSORIES (INCLUDED)	
1 X Island Trim, 1 X Full Access Telescopic Rack, 2 X Standard Racks, 1 X Broiler Pan	

WARRANTY	
Limited Warranty, Entire Appliance, Parts and Labor	2 Year

Also Available:
 PRL305PH - LP

FEATURES & BENEFITS

- ★ Exclusive, patented Star® Burner—most even heating, unsurpassed flame coverage
- ★ QuickClean Base® designed for easy surface cleaning
- ★ Precision simmering capabilities as low as 100°F (375 BTU) with 2 ExtraLow® Simmer burners
 - Professional style, continuous cast iron grates
 - Truly Flush Mounted™, 24" standard cabinet depth

TECHNICAL DETAILS

Circuit Breaker (A)	15 A
Volts (V)	120 V
Frequency (Hz)	60 Hz
Plug Type	120V-3 Prong
Power Cord Length (in)	72"
Energy Source	Gas
Gas Type	Natural Gas 15 mbar (USA)
Alternative Gas Type	Liquid Gas 27.5 mbar (USA)

See page 62 for optional accessories.

PRL305PH
30-INCH GAS PRO HARMONY® RANGE (LP)
 PROFESSIONAL SERIES, STANDARD-DEPTH, PORCELAIN COOKTOP SURFACE



GENERAL PROPERTIES	
Oven Capacity	4.4 cu. ft.
Cooking Modes - Main / Large Cavity	
Bake, Convection Bake, Broil, Extended Bake	
Cooking Modes - Small Cavity	N/A
Programs	Sabbath Function
Cleaning Type	N/A
Type of Grate	Continuous Cast Iron
Controls	Metal Knobs
Sealed Burners	Yes

OVEN PERFORMANCE	
Bake Power	22,000 BTU (LP)
Broil Power	22,600 BTU (LP)
Convection Power	N/A

BURNER PERFORMANCE	
Total Number of Cooktop Burners	5
Power of Front Left Burner BTU	9,100 (LP)
Power of Back Left Burner BTU	6,000 and XLO (LP)
Power of Back Center Burner BTU	12,000 (LP)
Power of Front Center Burner BTU	N/A
Power of Center 12" Electric Griddle (W)	N/A
Power of Center 12" Electric Grill (W)	N/A
Power of Far Right 12" Electric Griddle (W)	N/A
Power of Back Right Burner BTU	6,000 (LP)
Power of Front Right Burner BTU	14,000 and XLO (LP)

DIMENSIONS & WEIGHT	
Overall Appliance Dimensions (HxWxD) (in)	35 7/8"-36 3/4" x 29 15/16" x 24 3/4"
Required Cutout Size (HxWxD) (in)	35 7/8"-36 3/4" x 30" x 24"
Adjustable Range Height (in.)	7/8"
Net Weight (lbs)	336 lbs

ACCESSORIES (INCLUDED)	
1 X Island Trim, 1 X Full Access Telescopic Rack, 2 X Standard Racks, 1 X Broiler Pan	

WARRANTY	
Limited Warranty, Entire Appliance, Parts and Labor	2 Year

Also Available:
 PRG305PH - Natural Gas

FEATURES & BENEFITS

- ★ Exclusive, patented Star® Burner—most even heating, unsurpassed flame coverage
- ★ QuickClean Base® designed for easy surface cleaning
- ★ Precision simmering capabilities as low as 100°F (375 BTU) with 2 ExtraLow® Simmer burners
 - Professional style, continuous cast iron grates
 - Truly Flush Mounted™, 24" standard cabinet depth

TECHNICAL DETAILS

Circuit Breaker (A)	15 A
Volts (V)	120 V
Frequency (Hz)	60 Hz
Plug Type	120V-3 Prong
Power Cord Length (in)	72"
Energy Source	Gas
Gas Type	Liquid Gas 27.5 mbar (USA)
Alternative Gas Type	Natural Gas 15 mbar (USA)

See page 62 for optional accessories.

PRG366GH
36-INCH GAS PRO HARMONY® RANGE
 PROFESSIONAL SERIES, STANDARD-DEPTH, PORCELAIN COOKTOP SURFACE



GENERAL PROPERTIES	
Oven Capacity	5.0 cu. ft.
Cooking Modes - Main / Large Cavity	
Bake, Convection Bake, Broil, Extended Bake	
Cooking Modes - Small Cavity	N/A
Programs	Sabbath Function
Cleaning Type	N/A
Type of Grate	Continuous Cast Iron
Controls	Metal Knobs
Sealed Burners	Yes

OVEN PERFORMANCE	
Bake Power	27,000 BTU (NG)
Broil Power	20,000 BTU (NG)
Convection Power	N/A

BURNER PERFORMANCE	
Total Number of Cooktop Burners	6
Power of Front Left Burner BTU	18,000 and XLO (NG)
Power of Back Left Burner BTU	18,000 and XLO (NG)
Power of Back Center Burner BTU	18,000 (NG)
Power of Front Center Burner BTU	18,000 (NG)
Power of Center 12" Electric Griddle (W)	N/A
Power of Center 12" Electric Grill (W)	N/A
Power of Far Right 12" Electric Griddle (W)	N/A
Power of Back Right Burner BTU	18,000 (NG)
Power of Front Right Burner BTU	18,000 (NG)

DIMENSIONS & WEIGHT	
Overall Appliance Dimensions (HxWxD) (in)	35 7/8"-36 3/4" x 35 15/16" x 24 3/4"
Required Cutout Size (HxWxD) (in)	35 7/8"-36 3/4" x 36" x 24"
Adjustable Range Height (in.)	7/8"
Net Weight (lbs)	419 lbs

ACCESSORIES (INCLUDED)
 1 X Island Trim, 3 X Full Access Telescopic Racks, 1 X Broiler Pan

WARRANTY	
Limited Warranty, Entire Appliance, Parts and Labor	2 Year

Also Available:
 PRL366GH - LP

FEATURES & BENEFITS

- ★ - Exclusive, patented Star® Burner—most even heating, unsurpassed flame coverage
- ★ - QuickClean Base® designed for easy surface cleaning
- ★ - Precision simmering capabilities as low as 100°F (375 BTU) with 2 ExtraLow® Simmer burners
 - Professional style, continuous cast iron grates
 - Truly Flush Mounted™, 24" standard cabinet depth

TECHNICAL DETAILS

Circuit Breaker (A)	15 A
Volts (V)	120 V
Frequency (Hz)	60 Hz
Plug Type	120V-3 Prong
Power Cord Length (in)	72"
Energy Source	Gas
Gas Type	Natural Gas 15 mbar (USA)
Alternative Gas Type	Liquid Gas 27.5 mbar (USA)

See page 62 for optional accessories.

PRL366GH
36-INCH GAS PRO HARMONY® RANGE (LP)
 PROFESSIONAL SERIES, STANDARD-DEPTH, PORCELAIN COOKTOP SURFACE



GENERAL PROPERTIES	
Oven Capacity	5.0 cu. ft.
Cooking Modes - Main / Large Cavity	
Bake, Convection Bake, Broil, Extended Bake	
Cooking Modes - Small Cavity	N/A
Programs	Sabbath Function
Cleaning Type	N/A
Type of Grate	Continuous Cast Iron
Controls	Metal Knobs
Sealed Burners	Yes

OVEN PERFORMANCE	
Bake Power	25,000 BTU (LP)
Broil Power	19,000 BTU (LP)
Convection Power	N/A

BURNER PERFORMANCE	
Total Number of Cooktop Burners	6
Power of Front Left Burner BTU	15,000 and XLO (LP)
Power of Back Left Burner BTU	15,000 and XLO (LP)
Power of Back Center Burner BTU	15,000 (LP)
Power of Front Center Burner BTU	15,000 (LP)
Power of Center 12" Electric Griddle (W)	N/A
Power of Center 12" Electric Grill (W)	N/A
Power of Far Right 12" Electric Griddle (W)	N/A
Power of Back Right Burner BTU	15,000 (LP)
Power of Front Right Burner BTU	15,000 (LP)

DIMENSIONS & WEIGHT	
Overall Appliance Dimensions (HxWxD) (in)	35 7/8"-36 3/4" x 35 15/16" x 24 3/4"
Required Cutout Size (HxWxD) (in)	35 7/8"-36 3/4" x 36" x 24"
Adjustable Range Height (in.)	7/8"
Net Weight (lbs)	419 lbs

ACCESSORIES (INCLUDED)
 1 X Island Trim, 3 X Full Access Telescopic Racks, 1 X Broiler Pan

WARRANTY	
Limited Warranty, Entire Appliance, Parts and Labor	2 Year

Also Available:
 PRG366GH - Natural Gas

FEATURES & BENEFITS

- ★ - Exclusive, patented Star® Burner—most even heating, unsurpassed flame coverage
- ★ - QuickClean Base® designed for easy surface cleaning
- ★ - Precision simmering capabilities as low as 100°F (375 BTU) with 2 ExtraLow® Simmer burners
 - Professional style, continuous cast iron grates
 - Truly Flush Mounted™, 24" standard cabinet depth

TECHNICAL DETAILS

Circuit Breaker (A)	15 A
Volts (V)	120 V
Frequency (Hz)	60 Hz
Plug Type	120V-3 Prong
Power Cord Length (in)	72"
Energy Source	Gas
Gas Type	Liquid Gas 27.5 mbar (USA)
Alternative Gas Type	Natural Gas 15 mbar (USA)

See page 62 for optional accessories.

PRG364GDH
36-INCH GAS PRO HARMONY® RANGE WITH GRIDDLE
 PROFESSIONAL SERIES, STANDARD-DEPTH, PORCELAIN COOKTOP SURFACE



GENERAL PROPERTIES	
Oven Capacity	5.0 cu. ft.
Cooking Modes - Main / Large Cavity	
Bake, Convection Bake, Broil, Extended Bake	
Cooking Modes - Small Cavity	N/A
Programs	Sabbath Function
Cleaning Type	N/A
Type of Grate	Continuous Cast Iron
Controls	Metal Knobs
Sealed Burners	Yes

OVEN PERFORMANCE	
Bake Power	27,000 BTU (NG)
Broil Power	20,000 BTU (NG)
Convection Power	N/A

BURNER PERFORMANCE	
Total Number of Cooktop Burners	4 + Griddle
Power of Front Left Burner BTU	18,000 and XLO (NG)
Power of Back Left Burner BTU	18,000 and XLO (NG)
Power of Back Center Burner BTU	N/A
Power of Front Center Burner BTU	N/A
Power of Center 12" Electric Griddle (W)	1,630 W
Power of Center 12" Electric Grill (W)	N/A
Power of Far Right 12" Electric Griddle (W)	N/A
Power of Back Right Burner BTU	18,000 (NG)
Power of Front Right Burner BTU	18,000 (NG)

DIMENSIONS & WEIGHT	
Overall Appliance Dimensions (HxWxD) (in)	35 7/8"-36 3/4" x 35 15/16" x 24 3/4"
Required Cutout Size (HxWxD) (in)	35 7/8"-36 3/4" x 36" x 24"
Adjustable Range Height (in.)	7/8"
Net Weight (lbs)	399 lbs

ACCESSORIES (INCLUDED)
 1 X Island Trim, 3 X Full Access Telescopic Racks, 1 X Broiler Pan

WARRANTY	
Limited Warranty, Entire Appliance, Parts and Labor	2 Year

Also Available:
 PRL364GDH - LP

FEATURES & BENEFITS

- ★ - Exclusive, patented Star® Burner—most even heating, unsurpassed flame coverage
- ★ - QuickClean Base® designed for easy surface cleaning
- ★ - Precision simmering capabilities as low as 100°F (375 BTU) with 2 ExtraLow® Simmer burners
 - Professional style, continuous cast iron grates
 - Truly Flush Mounted™, 24" standard cabinet depth

TECHNICAL DETAILS

Circuit Breaker (A)	20 A
Volts (V)	120 V
Frequency (Hz)	60 Hz
Plug Type	120V-3 Prong NEMA 5-20
Power Cord Length (in)	72"
Energy Source	Gas
Gas Type	Natural Gas 15 mbar (USA)
Alternative Gas Type	Liquid Gas 27.5 mbar (USA)

See page 62 for optional accessories.

PRG364NLH
36-INCH GAS PRO HARMONY® RANGE WITH GRILL
 PROFESSIONAL SERIES, STANDARD-DEPTH, PORCELAIN COOKTOP SURFACE



GENERAL PROPERTIES	
Oven Capacity	5.0 cu. ft.
Cooking Modes - Main / Large Cavity	
Bake, Convection Bake, Broil, Extended Bake	
Cooking Modes - Small Cavity	N/A
Programs	Sabbath Function
Cleaning Type	N/A
Type of Grate	Continuous Cast Iron
Controls	Metal Knobs
Sealed Burners	Yes

OVEN PERFORMANCE	
Bake Power	27,000 BTU (NG)
Broil Power	20,000 BTU (NG)
Convection Power	N/A

BURNER PERFORMANCE	
Total Number of Cooktop Burners	4 + Grill
Power of Front Left Burner BTU	18,000 and XLO (NG)
Power of Back Left Burner BTU	18,000 and XLO (NG)
Power of Back Center Burner BTU	N/A
Power of Front Center Burner BTU	N/A
Power of Center 12" Electric Griddle (W)	N/A
Power of Center 12" Electric Grill (W)	1,630 W
Power of Far Right 12" Electric Griddle (W)	N/A
Power of Back Right Burner BTU	18,000 (NG)
Power of Front Right Burner BTU	18,000 (NG)

DIMENSIONS & WEIGHT	
Overall Appliance Dimensions (HxWxD) (in)	35 7/8"-36 3/4" x 35 15/16" x 24 3/4"
Required Cutout Size (HxWxD) (in)	35 7/8"-36 3/4" x 36" x 24"
Adjustable Range Height (in.)	7/8"
Net Weight (lbs)	451 lbs

ACCESSORIES (INCLUDED)
 1 X Island Trim, 3 X Full Access Telescopic Racks, 1 X Broiler Pan

WARRANTY	
Limited Warranty, Entire Appliance, Parts and Labor	2 Year

Also Available:
 PRL364NLH - LP

FEATURES & BENEFITS

- ★ - Exclusive, patented Star® Burner—most even heating, unsurpassed flame coverage
- ★ - QuickClean Base® designed for easy surface cleaning
- ★ - Precision simmering capabilities as low as 100°F (375 BTU) with 2 ExtraLow® Simmer burners
 - Professional style, continuous cast iron grates
 - Truly Flush Mounted™, 24" standard cabinet depth

TECHNICAL DETAILS

Circuit Breaker (A)	20 A
Volts (V)	120 V
Frequency (Hz)	60 Hz
Plug Type	120V-3 Prong
Power Cord Length (in)	72"
Energy Source	Gas
Gas Type	Natural Gas 15 mbar (USA)
Alternative Gas Type	Liquid Gas 27.5 mbar (USA)

See page 62 for optional accessories.

PRL364GDH

36-INCH GAS PRO HARMONY® RANGE WITH GRIDDLE (LP)

PROFESSIONAL SERIES, STANDARD-DEPTH, PORCELAIN COOKTOP SURFACE



Also Available:
PRG364GDH - Natural Gas

FEATURES & BENEFITS

- ★ - Exclusive, patented Star® Burner—most even heating, unsurpassed flame coverage
- ★ - QuickClean Base® designed for easy surface cleaning
- ★ - Precision simmering capabilities as low as 100°F (375 BTU) with 2 ExtraLow® Simmer burners
 - Professional style, continuous cast iron grates
 - Truly Flush Mounted™, 24" standard cabinet depth

TECHNICAL DETAILS

Circuit Breaker (A)	20 A
Volts (V)	120 V
Frequency (Hz)	60 Hz
Plug Type	120V-3 Prong NEMA 5-20
Power Cord Length (in)	72"
Energy Source	Gas
Gas Type	Liquid Gas 27.5 mbar (USA)
Alternative Gas Type	Natural Gas 15 mbar (USA)



GENERAL PROPERTIES

Oven Capacity	5.0 cu. ft.
Cooking Modes - Main / Large Cavity	
Bake, Convection Bake, Broil, Extended Bake	
Cooking Modes - Small Cavity	N/A
Programs	Sabbath Function
Cleaning Type	N/A
Type of Grate	Continuous Cast Iron
Controls	Metal Knobs
Sealed Burners	Yes

OVEN PERFORMANCE

Bake Power	25,000 BTU (LP)
Broil Power	19,000 BTU (LP)
Convection Power	N/A

BURNER PERFORMANCE

Total Number of Cooktop Burners	4 + Griddle
Power of Front Left Burner BTU	15,000 and XLO (LP)
Power of Back Left Burner BTU	15,000 and XLO (LP)
Power of Back Center Burner BTU	N/A
Power of Front Center Burner BTU	N/A
Power of Center 12" Electric Griddle (W)	1,630 W
Power of Center 12" Electric Grill (W)	N/A
Power of Far Right 12" Electric Griddle (W)	N/A
Power of Back Right Burner BTU	15,000 (LP)
Power of Front Right Burner BTU	15,000 (LP)

DIMENSIONS & WEIGHT

Overall Appliance Dimensions (HxWxD) (in)	35 7/8"–36 3/4" x 35 15/16" x 24 3/4"
Required Cutout Size (HxWxD) (in)	35 7/8"–36 3/4" x 36" x 24"
Adjustable Range Height (in.)	7/8"
Net Weight (lbs)	406 lbs

ACCESSORIES (INCLUDED)

1 X Island Trim, 3 X Full Access Telescopic Racks, 1 X Broiler Pan

WARRANTY

Limited Warranty, Entire Appliance, Parts and Labor	2 Year
---	--------

See page 62 for optional accessories.

PRL364NLH

36-INCH GAS PRO HARMONY® RANGE WITH GRILL (LP)

PROFESSIONAL SERIES, STANDARD-DEPTH, PORCELAIN COOKTOP SURFACE



Also Available:
PRG364NLH - Natural Gas

FEATURES & BENEFITS

- ★ - Exclusive, patented Star® Burner—most even heating, unsurpassed flame coverage
- ★ - QuickClean Base® designed for easy surface cleaning
- ★ - Precision simmering capabilities as low as 100°F (375 BTU) with 2 ExtraLow® Simmer burners
 - Professional style, continuous cast iron grates
 - Truly Flush Mounted™, 24" standard cabinet depth

TECHNICAL DETAILS

Circuit Breaker (A)	20 A
Volts (V)	120 V
Frequency (Hz)	60 Hz
Plug Type	120V-3 Prong
Power Cord Length (in)	72"
Energy Source	Gas
Gas Type	Liquid Gas 27.5 mbar (USA)
Alternative Gas Type	Natural Gas 15 mbar (USA)

GENERAL PROPERTIES

Oven Capacity	5.0 cu. ft.
Cooking Modes - Main / Large Cavity	
Bake, Convection Bake, Broil, Extended Bake	
Cooking Modes - Small Cavity	N/A
Programs	Sabbath Function
Cleaning Type	N/A
Type of Grate	Continuous Cast Iron
Controls	Metal Knobs
Sealed Burners	Yes

OVEN PERFORMANCE

Bake Power	25,000 BTU (LP)
Broil Power	19,000 BTU (LP)
Convection Power	N/A

BURNER PERFORMANCE

Total Number of Cooktop Burners	4 + Grill
Power of Front Left Burner BTU	15,000 and XLO (LP)
Power of Back Left Burner BTU	15,000 and XLO (LP)
Power of Back Center Burner BTU	N/A
Power of Front Center Burner BTU	N/A
Power of Center 12" Electric Griddle (W)	N/A
Power of Center 12" Electric Grill (W)	1,630 W
Power of Far Right 12" Electric Griddle (W)	N/A
Power of Back Right Burner BTU	15,000 (LP)
Power of Front Right Burner BTU	15,000 (LP)

DIMENSIONS & WEIGHT

Overall Appliance Dimensions (HxWxD) (in)	35 7/8"–36 3/4" x 35 15/16" x 24 3/4"
Required Cutout Size (HxWxD) (in)	35 7/8"–36 3/4" x 36" x 24"
Adjustable Range Height (in.)	7/8"
Net Weight (lbs)	374 lbs

ACCESSORIES (INCLUDED)

1 X Island Trim, 3 X Full Access Telescopic Racks, 1 X Broiler Pan

WARRANTY

Limited Warranty, Entire Appliance, Parts and Labor	2 Year
---	--------

See page 62 for optional accessories.

PRG486GDH
48-INCH GAS PRO HARMONY® RANGE WITH GRIDDLE
 PROFESSIONAL SERIES, STANDARD-DEPTH, PORCELAIN COOKTOP SURFACE



GENERAL PROPERTIES	
Oven Capacity	4.4 / 2.3 cu. ft.
Cooking Modes - Main / Large Cavity	
Bake, Convection Bake, Broil, Extended Bake	
Cooking Modes - Small Cavity	
Bake, Broil	
Programs	Sabbath Function (Main)
Cleaning Type	N/A
Type of Grate	Continuous Cast Iron
Controls	Metal Knobs
Sealed Burners	Yes

OVEN PERFORMANCE	
Bake Power	23,500 BTU (Lg) / 15,000 BTU (Sm) (NG)
Broil Power	20,000 BTU (Lg) / 7,500 BTU (Sm) (NG)
Convection Power	N/A

BURNER PERFORMANCE	
Total Number of Cooktop Burners	6 + Griddle
Power of Front Left Burner BTU	18,000 and XLO (NG)
Power of Back Left Burner BTU	18,000 and XLO (NG)
Power of Back Center Burner BTU	18,000 (NG)
Power of Front Center Burner BTU	18,000 (NG)
Power of Center 12" Electric Griddle (W)	1,630 W
Power of Center 12" Electric Grill (W)	N/A
Power of Far Right 12" Electric Griddle (W)	N/A
Power of Back Right Burner BTU	18,000 (NG)
Power of Front Right Burner BTU	18,000 (NG)

DIMENSIONS & WEIGHT	
Overall Appliance Dimensions (HxWxD) (in)	35 7/8" - 36 3/4" x 47 7/8" x 24 3/4"
Required Cutout Size (HxWxD) (in)	35 7/8" - 36 3/4" x 48" x 24"
Adjustable Range Height (in.)	7/8"
Net Weight (lbs)	565 lbs

ACCESSORIES (INCLUDED)	
1 X Island Trim, 3 X Full Access Telescopic Racks, 2 X Telescopic Rack - Small, 1 X Broiler Pan, 1 X Broiler Pan Small	

WARRANTY	
Limited Warranty, Entire Appliance, Parts and Labor	2 Year

Also Available:
 PRL486GDH - LP

FEATURES & BENEFITS

- ★ - Exclusive, patented Star® Burner—most even heating, unsurpassed flame coverage
- ★ - QuickClean Base® designed for easy surface cleaning
- ★ - Precision simmering capabilities as low as 100°F (375 BTU) with 2 ExtraLow® Simmer burners
 - Professional style, continuous cast iron grates
 - Truly Flush Mounted™, 24" standard cabinet depth

TECHNICAL DETAILS

Circuit Breaker (A)	20 A
Volts (V)	120 V
Frequency (Hz)	60 Hz
Plug Type	120V-3 Prong NEMA 5-20
Power Cord Length (in)	72"
Energy Source	Gas
Gas Type	Natural Gas 15 mbar (USA)
Alternative Gas Type	Liquid Gas 27.5 mbar (USA)

See page 63 for optional accessories.

PRG486NLH
48-INCH GAS PRO HARMONY® RANGE WITH GRILL
 PROFESSIONAL SERIES, STANDARD-DEPTH, PORCELAIN COOKTOP SURFACE



GENERAL PROPERTIES	
Oven Capacity	4.4 / 2.3 cu. ft.
Cooking Modes - Main / Large Cavity	
Bake, Convection Bake, Broil, Extended Bake	
Cooking Modes - Small Cavity	
Bake, Broil	
Programs	Sabbath Function (Main)
Cleaning Type	N/A
Type of Grate	Continuous Cast Iron
Controls	Metal Knobs
Sealed Burners	Yes

OVEN PERFORMANCE	
Bake Power	23,500 BTU (Lg) / 15,000 BTU (Sm) (NG)
Broil Power	20,000 BTU (Lg) / 7,500 BTU (Sm) / (NG)
Convection Power	N/A

BURNER PERFORMANCE	
Total Number of Cooktop Burners	6 + Grill
Power of Front Left Burner BTU	18,000 and XLO (NG)
Power of Back Left Burner BTU	18,000 and XLO (NG)
Power of Back Center Burner BTU	18,000 (NG)
Power of Front Center Burner BTU	18,000 (NG)
Power of Center 12" Electric Griddle (W)	N/A
Power of Center 12" Electric Grill (W)	1,630 W
Power of Far Right 12" Electric Griddle (W)	N/A
Power of Back Right Burner BTU	18,000 (NG)
Power of Front Right Burner BTU	18,000 (NG)

DIMENSIONS & WEIGHT	
Overall Appliance Dimensions (HxWxD) (in)	35 7/8" - 36 3/4" x 47 7/8" x 24 3/4"
Required Cutout Size (HxWxD) (in)	35 7/8" - 36 3/4" x 48" x 24"
Adjustable Range Height (in.)	7/8"
Net Weight (lbs)	540 lbs

ACCESSORIES (INCLUDED)	
1 X Island Trim, 3 X Full Access Telescopic Racks, 2 X Telescopic Rack - Small, 1 X Broiler Pan, 1 X Broiler Pan Small	

WARRANTY	
Limited Warranty, Entire Appliance, Parts and Labor	2 Year

Also Available:
 PRL486NLH - LP

FEATURES & BENEFITS

- ★ - Exclusive, patented Star® Burner—most even heating, unsurpassed flame coverage
- ★ - QuickClean Base® designed for easy surface cleaning
- ★ - Precision simmering capabilities as low as 100°F (375 BTU) with 2 ExtraLow® Simmer burners
 - Professional style, continuous cast iron grates
 - Truly Flush Mounted™, 24" standard cabinet depth

TECHNICAL DETAILS

Circuit Breaker (A)	20 A
Volts (V)	120 V
Frequency (Hz)	60 Hz
Plug Type	120V-3 Prong
Power Cord Length (in)	72"
Energy Source	Gas
Gas Type	Natural Gas 15 mbar (USA)
Alternative Gas Type	Liquid Gas 27.5 mbar (USA)

See page 63 for optional accessories.

PRL486GDH

48-INCH GAS PRO HARMONY® RANGE WITH GRIDDLE (LP)

PROFESSIONAL SERIES, STANDARD-DEPTH, PORCELAIN COOKTOP SURFACE



GENERAL PROPERTIES	
Oven Capacity	4.4 / 2.3 cu. ft.
Cooking Modes - Main / Large Cavity	
Bake, Convection Bake, Broil, Extended Bake	
Cooking Modes - Small Cavity	
Bake, Broil	
Programs	Sabbath Function (Main)
Cleaning Type	N/A
Type of Grate	Continuous Cast Iron
Controls	Metal Knobs
Sealed Burners	Yes

OVEN PERFORMANCE	
Bake Power	22,000 BTU (Lg) / 12,300 BTU (Sm) (LP)
Broil Power	19,000 BTU (Lg) / 6,500 BTU (Sm) (LP)
Convection Power	N/A

BURNER PERFORMANCE	
Total Number of Cooktop Burners	6 + Griddle
Power of Front Left Burner BTU	15,000 and XLO (LP)
Power of Back Left Burner BTU	15,000 and XLO (LP)
Power of Back Center Burner BTU	15,000 (LP)
Power of Front Center Burner BTU	15,000 (LP)
Power of Center 12" Electric Griddle (W)	1,630 W
Power of Center 12" Electric Grill (W)	N/A
Power of Far Right 12" Electric Griddle (W)	N/A
Power of Back Right Burner BTU	15,000 (LP)
Power of Front Right Burner BTU	15,000 (LP)

DIMENSIONS & WEIGHT	
Overall Appliance Dimensions (HxWxD) (in)	35 7/8" - 36 3/4" x 47 7/8" x 24 3/4"
Required Cutout Size (HxWxD) (in)	35 7/8" - 36 3/4" x 48" x 24"
Adjustable Range Height (in.)	7/8"
Net Weight (lbs)	565 lbs

ACCESSORIES (INCLUDED)	
1 X Island Trim, 3 X Full Access Telescopic Racks, 2 X Telescopic Rack - Small, 1 X Broiler Pan, 1 X Broiler Pan Small	

WARRANTY	
Limited Warranty, Entire Appliance, Parts and Labor	2 Year

Also Available:
PRG486GDH - Natural Gas

FEATURES & BENEFITS

- ★ - Exclusive, patented Star® Burner—most even heating, unsurpassed flame coverage
- ★ - QuickClean Base® designed for easy surface cleaning
- ★ - Precision simmering capabilities as low as 100°F (375 BTU) with 2 ExtraLow® Simmer burners
 - Professional style, continuous cast iron grates
 - Truly Flush Mounted™, 24" standard cabinet depth

TECHNICAL DETAILS

Circuit Breaker (A)	20 A
Volts (V)	120 V
Frequency (Hz)	60 Hz
Plug Type	120V-3 Prong NEMA 5-20
Power Cord Length (in)	72"
Energy Source	Gas
Gas Type	Liquid Gas 27.5 mbar (USA)
Alternative Gas Type	Natural Gas 15 mbar (USA)

See page 63 for optional accessories.

PRL486NLH

48-INCH GAS PRO HARMONY® RANGE WITH GRILL (LP)

PROFESSIONAL SERIES, STANDARD-DEPTH, PORCELAIN COOKTOP SURFACE



GENERAL PROPERTIES	
Oven Capacity	4.4 / 2.3 cu. ft.
Cooking Modes - Main / Large Cavity	
Bake, Convection Bake, Broil, Extended Bake	
Cooking Modes - Small Cavity	
Bake, Broil	
Programs	Sabbath Function (Main)
Cleaning Type	N/A
Type of Grate	Continuous Cast Iron
Controls	Metal Knobs
Sealed Burners	Yes

OVEN PERFORMANCE	
Bake Power	22,000 BTU (Lg) / 12,300 BTU (Sm) (LP)
Broil Power	19,000 BTU (Lg) / 6,500 BTU (Sm) (LP)
Convection Power	N/A

BURNER PERFORMANCE	
Total Number of Cooktop Burners	6 + Grill
Power of Front Left Burner BTU	15,000 and XLO (LP)
Power of Back Left Burner BTU	15,000 and XLO (LP)
Power of Back Center Burner BTU	15,000 (LP)
Power of Front Center Burner BTU	15,000 (LP)
Power of Center 12" Electric Griddle (W)	N/A
Power of Center 12" Electric Grill (W)	1,630 W
Power of Far Right 12" Electric Griddle (W)	N/A
Power of Back Right Burner BTU	15,000 (LP)
Power of Front Right Burner BTU	15,000 (LP)

DIMENSIONS & WEIGHT	
Overall Appliance Dimensions (HxWxD) (in)	35 7/8" - 36 3/4" x 47 7/8" x 24 3/4"
Required Cutout Size (HxWxD) (in)	35 7/8" - 36 3/4" x 48" x 24"
Adjustable Range Height (in.)	7/8"
Net Weight (lbs)	540 lbs

ACCESSORIES (INCLUDED)	
1 X Island Trim, 3 X Full Access Telescopic Racks, 2 X Telescopic Rack - Small, 1 X Broiler Pan, 1 X Broiler Pan Small	

WARRANTY	
Limited Warranty, Entire Appliance, Parts and Labor	2 Year

Also Available:
PRG486NLH - Natural Gas

FEATURES & BENEFITS

- ★ - Exclusive, patented Star® Burner—most even heating, unsurpassed flame coverage
- ★ - QuickClean Base® designed for easy surface cleaning
- ★ - Precision simmering capabilities as low as 100°F (375 BTU) with 2 ExtraLow® Simmer burners
 - Professional style, continuous cast iron grates
 - Truly Flush Mounted™, 24" standard cabinet depth

TECHNICAL DETAILS

Circuit Breaker (A)	20 A
Volts (V)	120 V
Frequency (Hz)	60 Hz
Plug Type	120V-3 Prong
Power Cord Length (in)	72"
Energy Source	Gas
Gas Type	Liquid Gas 27.5 mbar (USA)
Alternative Gas Type	Natural Gas 15 mbar (USA)

See page 63 for optional accessories.

PRO HARMONY® RANGES

PLANNING INFORMATION

MODEL OPTIONS

There are three sizes of Thermador Pro Harmony Ranges to choose from—30-inch, 36-inch and 48-inch. All models are available in your choice of all-gas or dual-fuel configurations. Pro Harmony Ranges feature a compact, 24-inch deep design in stainless steel with porcelain cooktop surface. Dual-fuel models are LP convertible by ordering the specified kit. All-gas models are available in Natural Gas or Liquid Propane and should be ordered separately from the factory. Be sure to reference the correct model information in this design guide.

INSTALLATION CONSIDERATIONS

The information in this design guide provides key features, product dimensions, cutouts and installation specifications. Before installing a Thermador Pro Harmony Range, be sure to verify the cutout dimensions and electrical / gas connections. Also, always consult with the installation manual packed with the product for complete details before installing.

INSTALLATION OPTIONS

Thermador Pro Harmony® Ranges feature a bold, professional design and a compact, 24-inch depth profile that creates a seamless look within standard cabinetry. These ranges can be installed in a wall or island installation.

BACKGUARDS

When using the Flush Island Trim, Thermador recommends a minimum 12" (305 mm) rear clearance to a combustible surface (see Figure 1, Cabinet Clearances). Clearances from non-combustible materials are not part of the ANSI Z21.1 scope and are not certified by CSA. Clearances of less than 12" (305 mm) must be approved by the local codes and / or by the local authority having jurisdiction.

NATURAL GAS OR LP

Thermador Dual-Fuel Pro Harmony Ranges are shipped by the factory to operate on natural gas. They must be converted for use with propane. Verify that the type of gas being used at the installation site matches the type of gas used by the appliance. If the location / job site requires conversion from natural gas to propane (LP), order an LP conversion kit. Field conversion must be done by qualified service personnel only. Please refer to the LP Conversion Instructions packed with product for further information.

VENTILATION REQUIREMENTS

We strongly recommend that a Thermador Professional® Wall or Island Hood or Custom Insert be installed with all Thermador Pro Harmony Ranges. Downdraft ventilation should not be used. Do not install a microwave-hood combination above the cooktop, as these types of units do not provide the proper ventilation and are not suitable for use with Thermador Pro Harmony Ranges.

For high output gas cooktops (60,000 BTU or greater), the minimum of one (1) CFM of ventilation per 100 BTU is recommended. If the cooktop has a grill or griddle, add 150 CFM to the estimated blower capacity. Additional blower capacity may be required for longer duct runs.

VENTILATION REQUIREMENTS (CONTINUED)

The following table indicates the ventilation hood options that are recommended for use with Thermador Pro Harmony Ranges. Refer to the Ventilation section or www.Thermador.com for a complete selection of Professional ventilation options, blowers, and accessories.

WIDTH	CONFIGURATION	VENTILATION OPTIONS
30"	4 Burners	30" or 36" Pro Wall Hood 42" Island Hood 36" Custom Insert
30"	5 Burners	30" or 36" Pro Wall Hood 42" Island Hood 36" Custom Insert
36"	4 Burners w/Grill OR Griddle	36" or 42" Pro Wall Hood 36" Chimney Wall Hood 42" Island Hood 36" Custom Insert
36"	6 Burners	36" or 42" Pro Wall Hood 36" Chimney Wall Hood 42" Island Hood 36" Custom Insert
48"	4 Burners w/Grill AND Griddle	48" or 54" Pro Wall Hood 48" Chimney Wall Hood 42" Island Hood 48" or 54" Custom Insert
48"	6 Burners w/Grill OR Griddle	48" or 54" Pro Wall Hood 48" Chimney Wall Hood 42" Island Hood 48" or 54" Custom Insert

IMPORTANT VENTILATION NOTES:

- Due to the high surface temperature output of the Pro Harmony Ranges (excluding 5-burner models), the HPWB Professional Series Wall Hoods or the Professional Series Custom Inserts are recommended ventilation solution for these ranges. The PH Professional Series Wall Hoods are also a viable option.
- For wall installations, the hood width must, at a minimum, equal the nominal width of the appliance cooking surface. Where space permits, a hood larger in width than the cooking surface may be desirable for improved ventilation performance.
- For island installations, the hood width should, at a minimum, overhang the appliance cooking surface by 3" on each side.
- Due to the high heat capability of these cooktops, particular attention should be paid to the hood and duct work installation to assure it meets local building codes.
- For best smoke elimination, the lower edge of the hood should be installed 30"–36" above the appliance cooking surface.
- If the hood contains any combustible materials (i.e., a wood covering), it must be 36" or greater distance above the cooking surface.

ELECTRICAL AND GAS SPECIFICATIONS

Be sure your appliance is properly installed and grounded by a qualified technician. Installation, electrical and gas connections, and grounding must comply with all applicable local codes.

GAS REQUIREMENTS AND HOOKUP

Verify that the type of gas being used at the installation site matches the type of gas used by the appliance. If an LP kit is utilized (PALPKITHC), conversion from natural gas to propane must be done by qualified service personnel only. Please refer to the LP Conversion Instructions packed with product for further information.

A manual gas shut-off valve must be installed external to the appliance, in a location accessible from the front, for the purpose of shutting off the gas supply. The supply line must not interfere with the back of the unit.

NATURAL GAS REQUIREMENTS:

Inlet Connection: 3/4" NPT external, 1/2" NPT internal (Minimum 3/4" diam. flex line.)
Supply Pressure: 6" min. to 14" max. water column. (14.9 mb to 34.9 mb)
Manifold Pressure: 5" water column (12.5 mb)

PROPANE GAS REQUIREMENTS:

Inlet Connection: 3/4" NPT external, 1/2" NPT internal (Minimum 3/4" diam. flex line.)
Supply Pressure: 11" min. to 14" max. water column. (27.4 mb to 34.9 mb)
Manifold Pressure: 10" water column (24.9 mb)

DUAL-FUEL:

Thermador Pro Harmony Dual-Fuel Ranges are dual rated, designed to be connected to either 240 / 208V AC, 60 Hz, 4-wire, single-phase power supply. The connection may be made with a range supply cord kit (purchased separately) or by hard-wiring to the power supply. A dedicated circuit breaker is required.

MODEL	REQUIRED CIRCUIT BREAKER
	240 / 208V AC, 60 Hz
PRD304GHU	35 A
PRD305PH	35 A
PRD364GDHU	35 A
PRD364NLHU	40 A
PRD366GHU	35 A
PRD486GDHU	50 A
PRD486NLHU	50 A
PRD484NCHU	50 A

PRO HARMONY® RANGES

PLANNING INFORMATION

ALL-GAS:

Thermador Pro Harmony All-Gas Ranges are equipped with a 3-wire plug and are designed to be connected to a 120V AC, 60 Hz, single-phase power supply. A dedicated circuit breaker is required.

MODEL	REQUIRED CIRCUIT BREAKER
	120V AC, 60 Hz
PRG304GH	15 A
PRL304GH	15 A
PRG305PH	15 A
PRL305PH	15 A
PRG366GH	15 A
PRL366GH	15 A
PRG364GDH	20 A
PRG364NLH	20 A
PRL364GDH	20 A
PRL364NLH	20 A
PRG486GDH	20 A
PRG486NLH	20 A
PRL486GDH	20 A
PRL486NLH	20 A

ELECTRICAL SUPPLY

IMPORTANT: The cord supplied with gas ranges having an electric griddle requires a NEMA 5-20 receptacle as shown here. Local codes may require a different wiring method.

NEMA 5-20 RECEPTACLE



PLUG



WARNING: This appliance is equipped with a three-prong grounding plug for protection against shock hazard and should be plugged directly into a properly grounded receptacle. DO NOT cut or remove the grounding prong from this plug. DO NOT ALTER THIS PLUG.

ELECTRICAL AND GAS LOCATIONS

Typical placement of the electrical and gas supply can be found within the "Cutout and Range Dimensions" located on the installation pages. Alternate placement within the supply zone is acceptable. Dual-Fuel ranges may be connected to the power supply with a range supply cord kit (sold separately) or by hard-wiring to the power supply. All-gas ranges may be connected to the power supply with the supplied range cord or by hard-wiring. It is the responsibility of the installer to provide the proper wiring components (cord or conduit and wires) and complete the electrical connection as dictated by local codes and ordinances and / or the National Electric Code. The units must be properly grounded.

Installation of the range must be planned so that the rough-in of the junction box for the receptacle or conduit connection will allow maximum clearance to the rear of the unit.

30-INCH RANGE DIMENSIONS

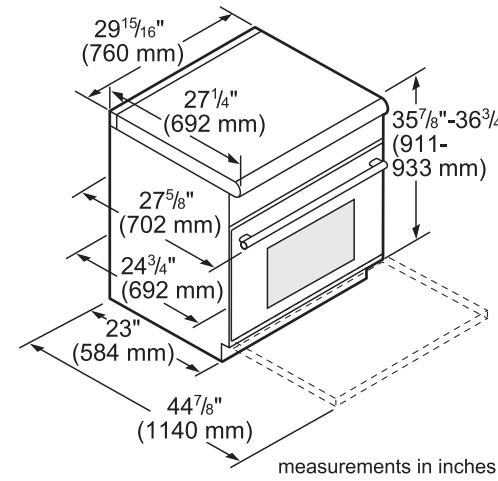

30-INCH RANGE CUTOUT DIMENSIONS

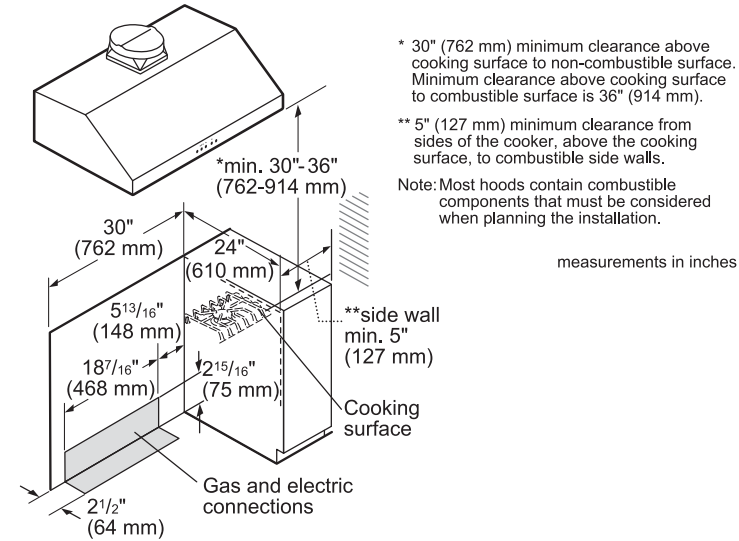

* 30" (762 mm) minimum clearance above cooking surface to non-combustible surface. Minimum clearance above cooking surface to combustible surface is 36" (914 mm).
** 5" (127 mm) minimum clearance from sides of the cooker, above the cooking surface, to combustible side walls.
Note: Most hoods contain combustible components that must be considered when planning the installation.

measurements in inches

PRD304GHU, PRG304GH, PRL304GH
30-INCH RANGE CUTOUT DIMENSIONS (4-BURNER MODELS)

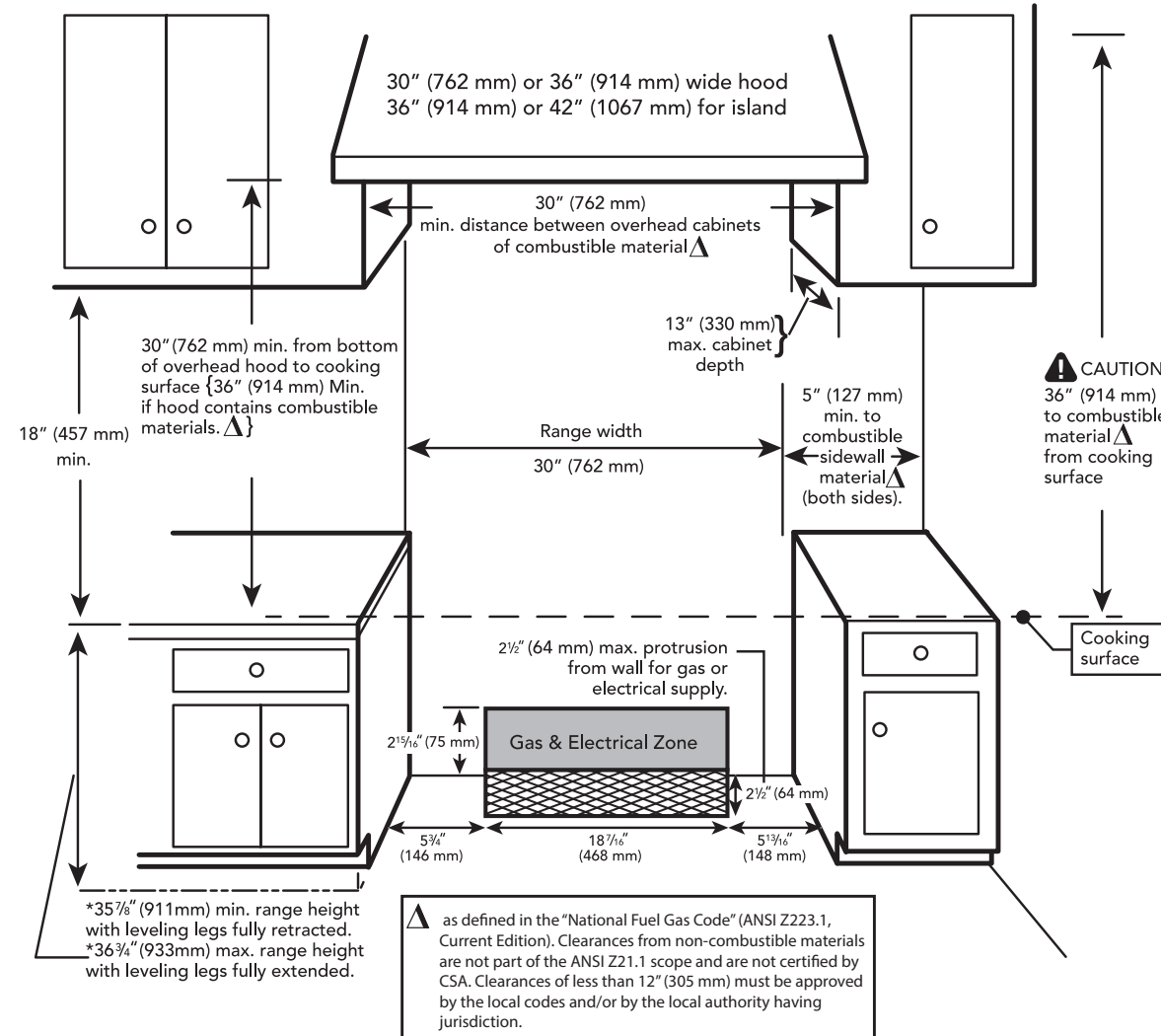

▲ as defined in the "National Fuel Gas Code" (ANSI Z223.1, Current Edition). Clearances from non-combustible materials are not part of the ANSI Z21.1 scope and are not certified by CSA. Clearances of less than 12" (305 mm) must be approved by the local codes and/or by the local authority having jurisdiction.

PRD305PH, PRG305PH, PRL305PH
30-INCH RANGE CABINET
CLEARANCES WITH HOOD
(5-BURNER MODELS)

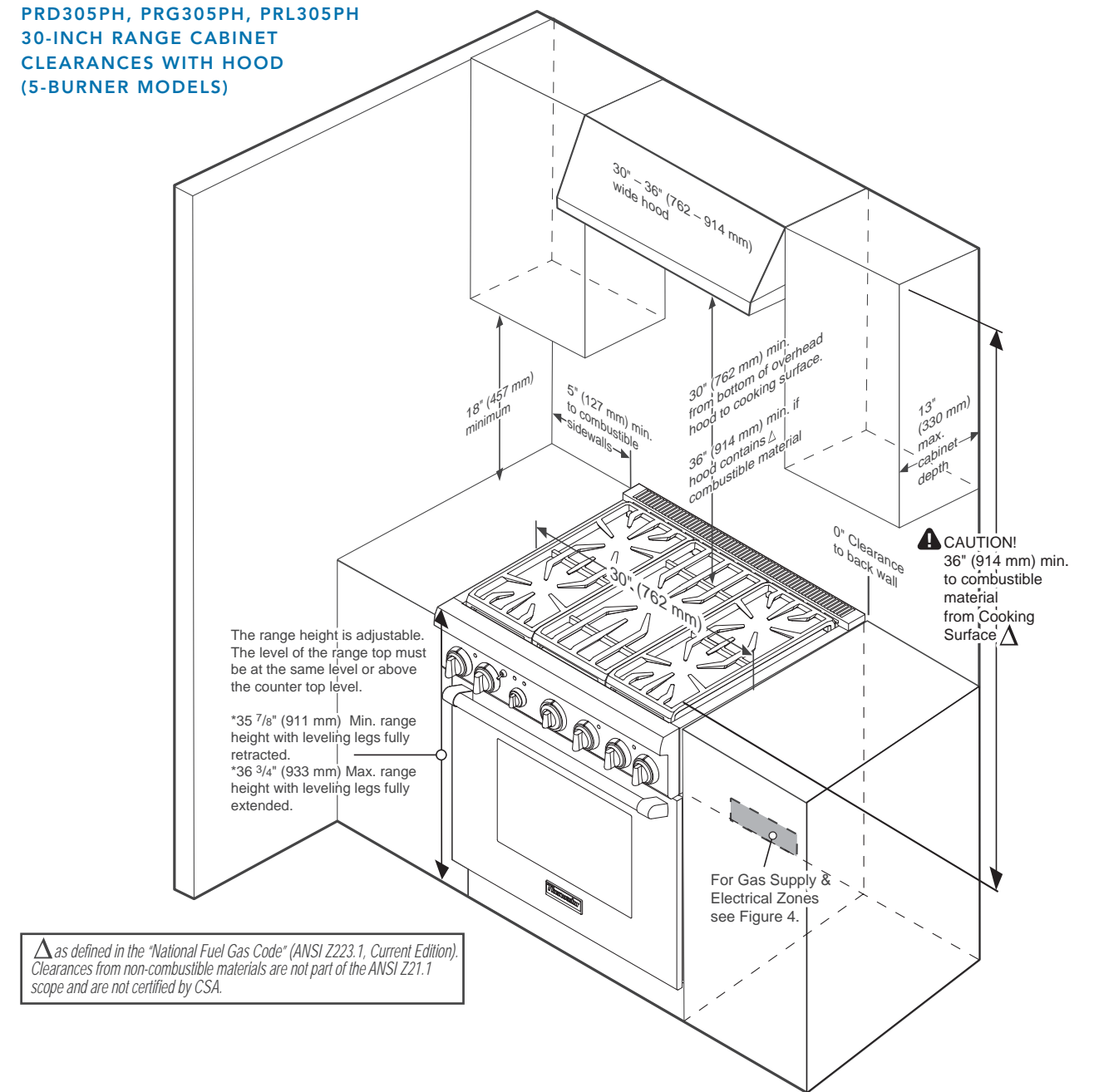

▲ as defined in the "National Fuel Gas Code" (ANSI Z223.1, Current Edition). Clearances from non-combustible materials are not part of the ANSI Z21.1 scope and are not certified by CSA.

PRD305PH, PRG305PH, PRL305PH
FIGURE 4

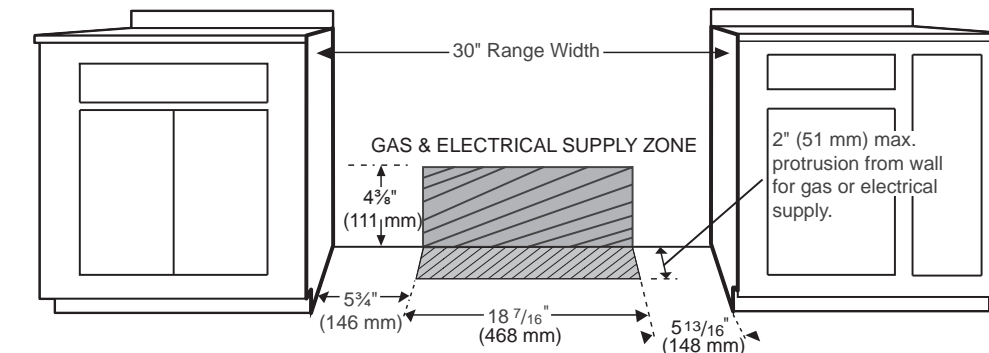

PRO HARMONY® RANGES INSTALLATION

PRD305PH, PRG305PH, PRL305PH 30-INCH RANGE CABINET CLEARANCES WITH OVER-THE-RANGE MICROWAVE (5-BURNER MODELS)

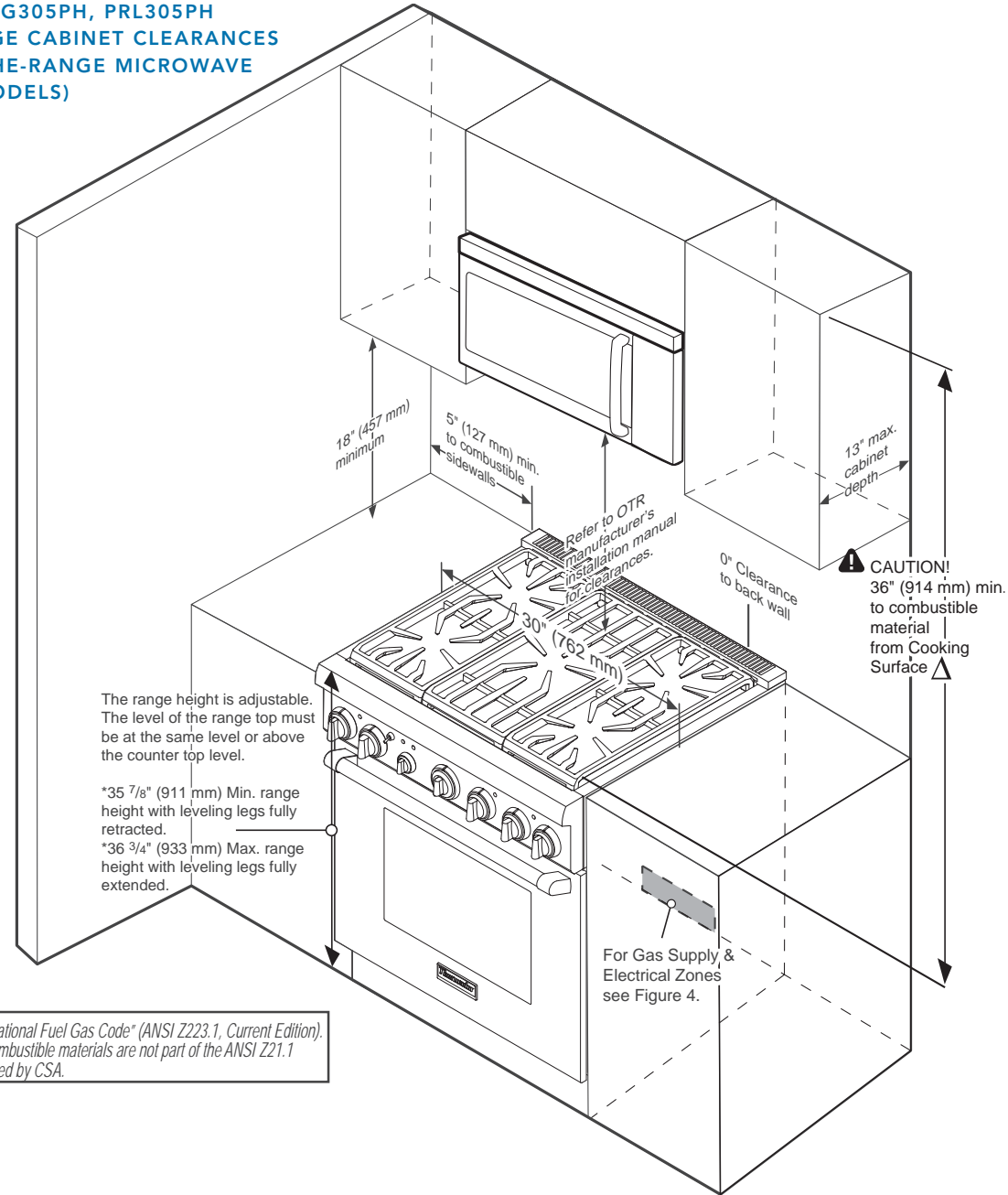

△ as defined in the "National Fuel Gas Code" (ANSI Z223.1, Current Edition). Clearances from non-combustible materials are not part of the ANSI Z21.1 scope and are not certified by CSA.

PRD305PH, PRG305PH, PRL305PH FIGURE 4

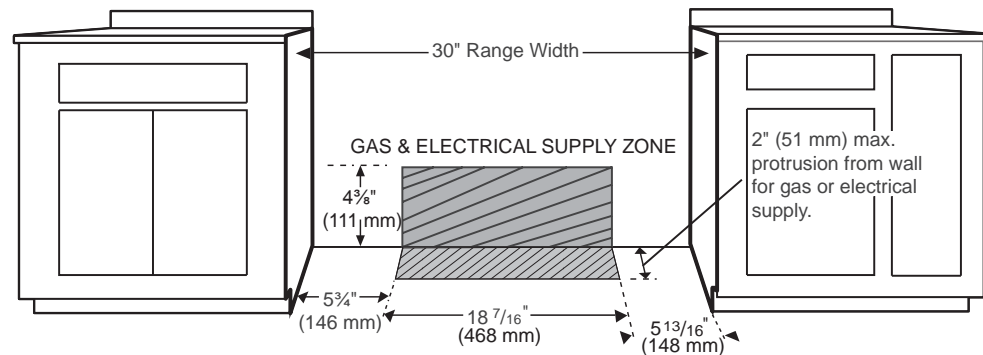

PRO HARMONY® RANGES INSTALLATION

PRD305PH, PRG305PH, PRL305PH 30-INCH RANGE DIMENSIONS AND SIDE CLEARANCE REQUIREMENTS (5-BURNER MODELS)

NOTE: A 36-inch minimum clearance is required between the top of the cooking surface and the bottom of an unprotected cabinet. A 30-inch clearance can be used when the bottom of the wood or metal cabinet is protected by not less than 1/4 inch of a flame retardant material covered with not less than No. 28 MSG sheet steel, 0.015 inch (0.4 mm) thick stainless steel, 0.024 inch (0.6 mm) aluminum, or 0.020 inch (0.5 mm) thick copper.

△ as defined in the "National Fuel Gas Code" (ANSI Z223.1, Current Edition). Clearances from non-combustible materials are not part of the ANSI Z21.1 scope and are not certified by CSA.

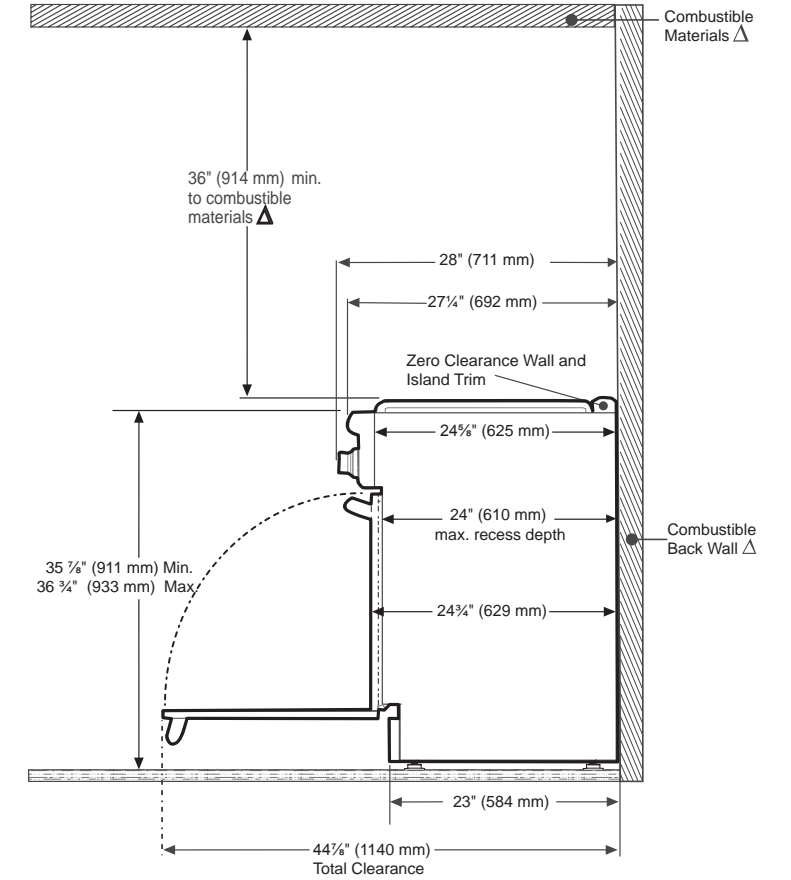

PRO HARMONY® RANGES INSTALLATION

36-INCH RANGE DIMENSIONS

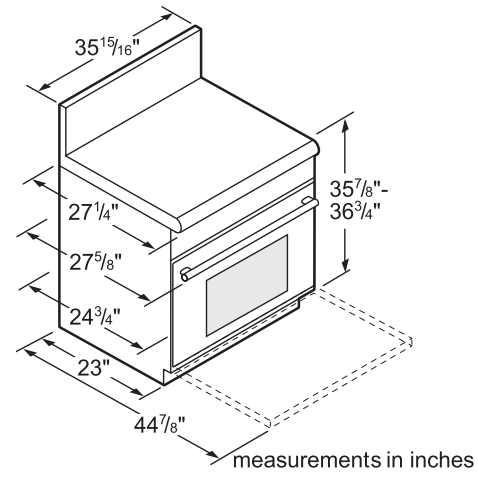

36-INCH RANGE CUTOUT DIMENSIONS

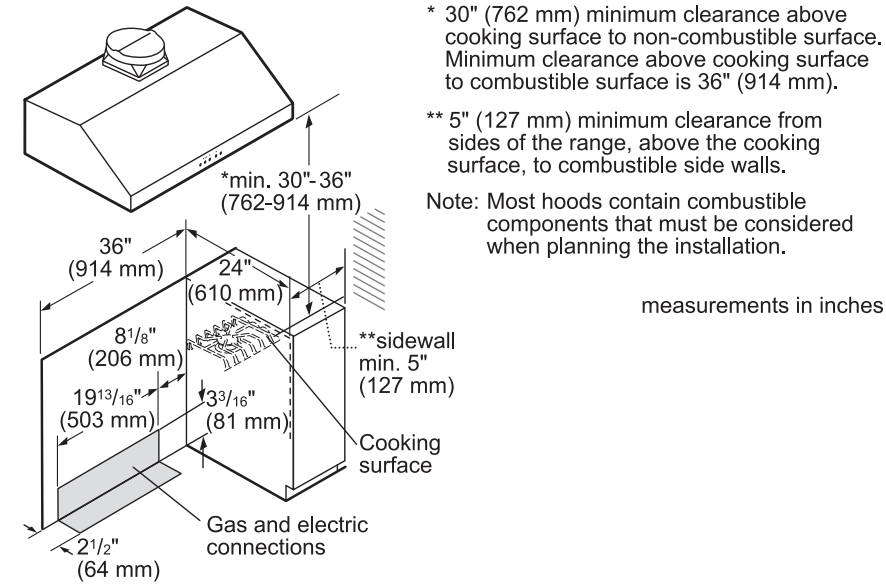

36-INCH RANGE CUTOUT DIMENSIONS

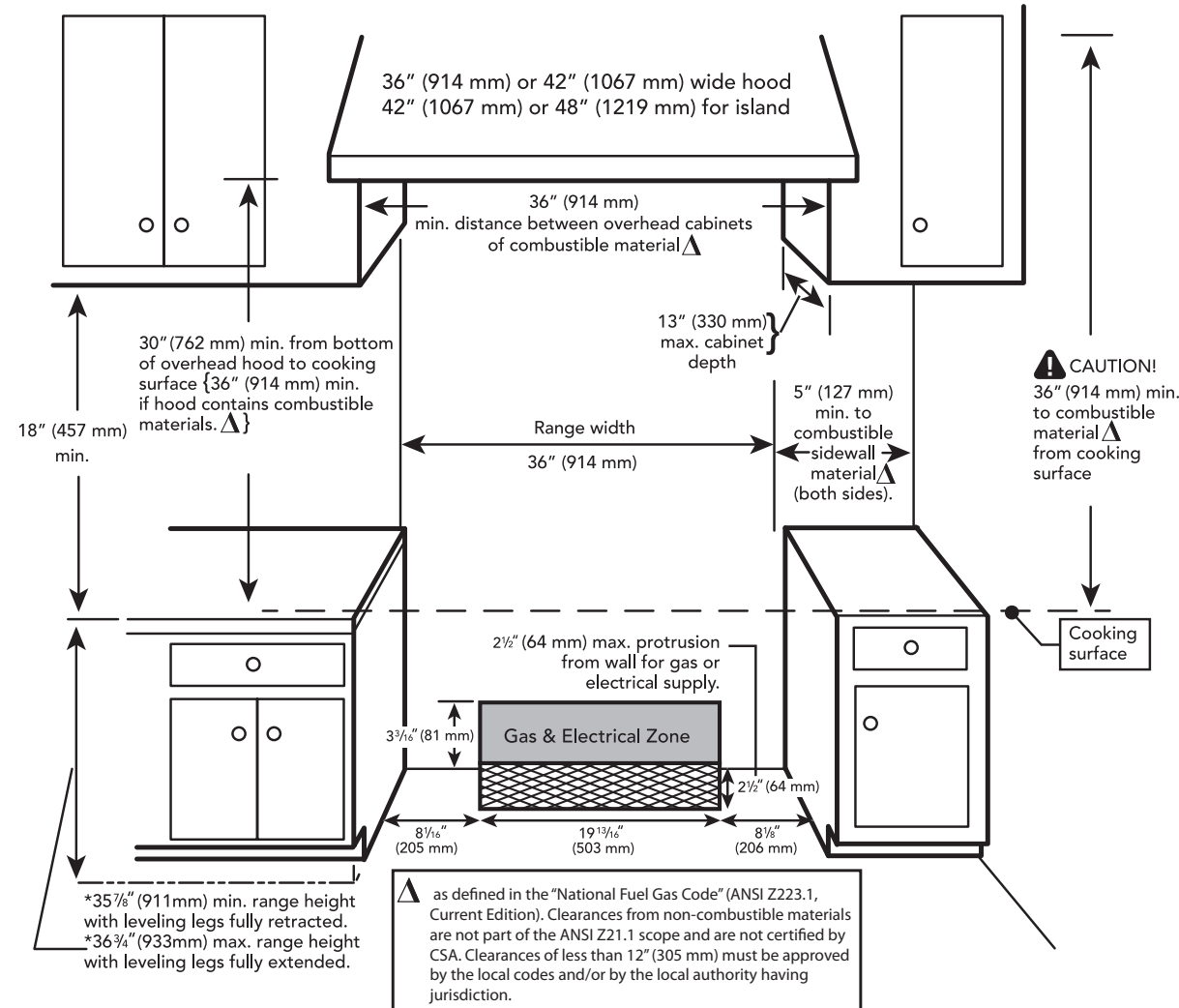

48-INCH RANGE DIMENSIONS

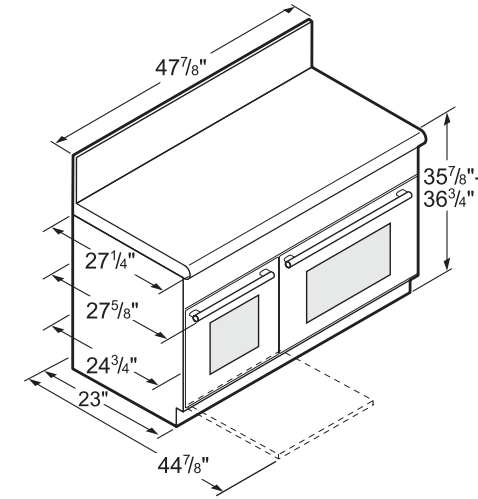

48-INCH RANGE CUTOUT DIMENSIONS

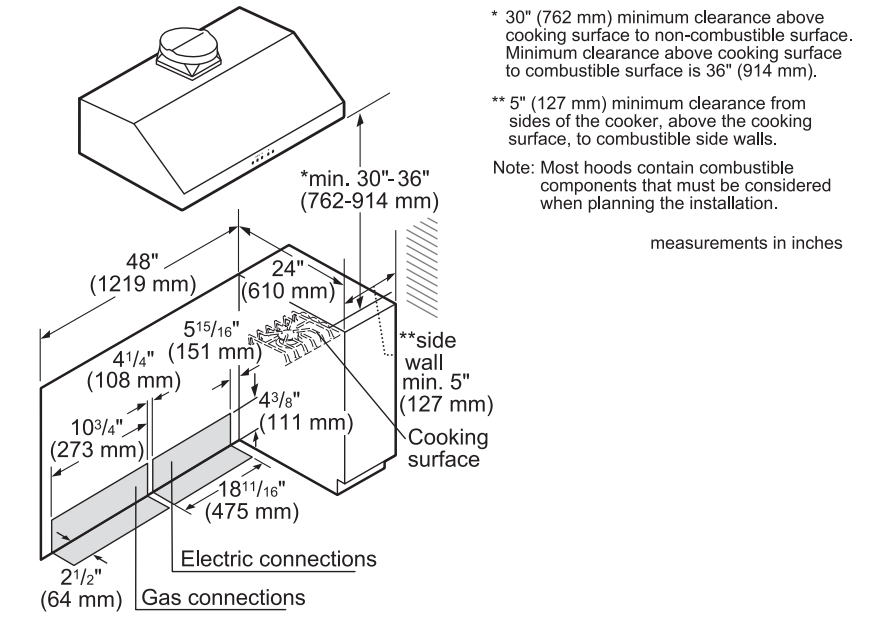

48-INCH RANGE CUTOUT DIMENSIONS

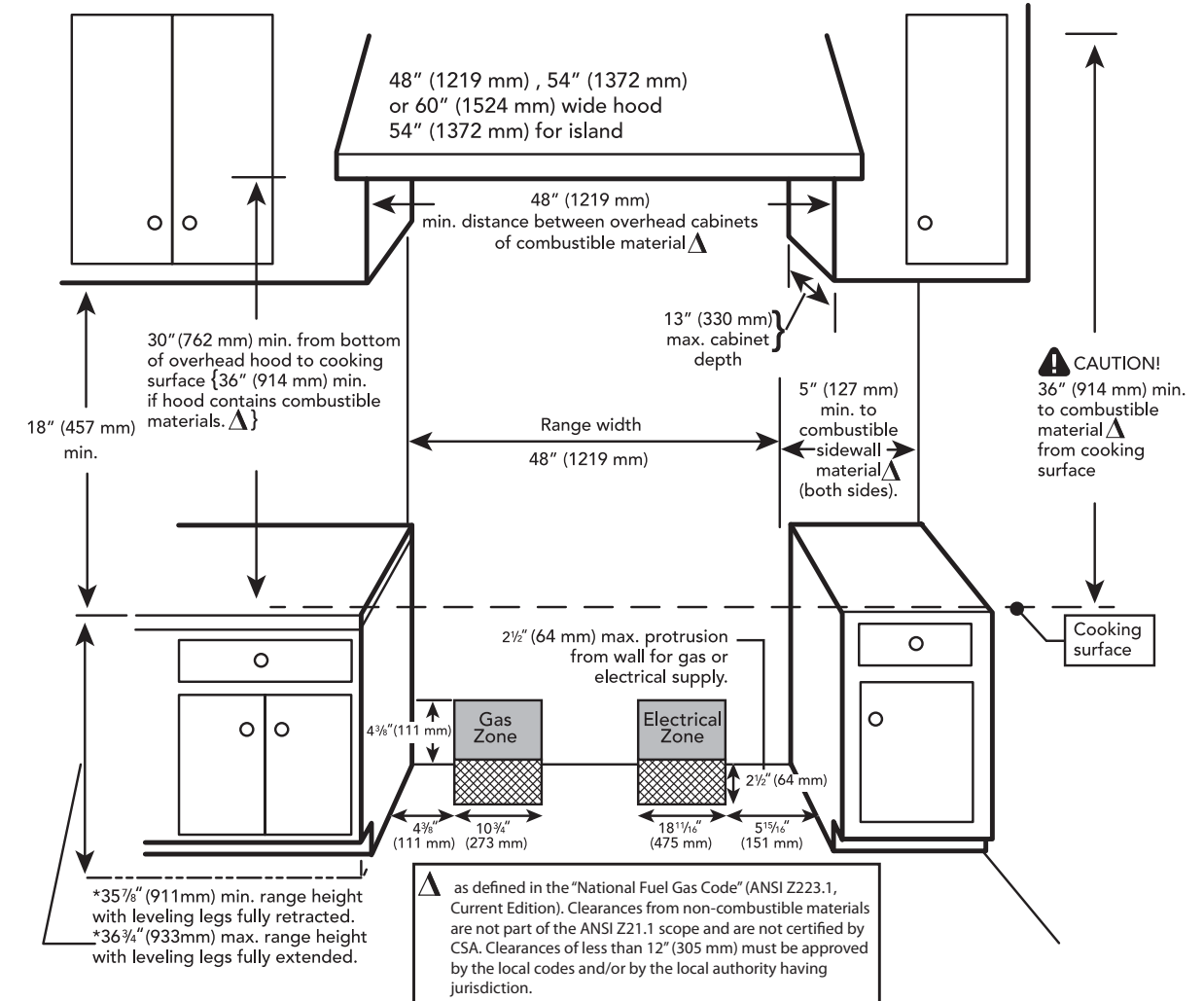

PRO HARMONY® RANGES INSTALLATION

30-INCH (4-BURNER MODELS), 36-INCH & 48-INCH PRO HARMONY RANGE DIMENSIONS AND CLEARANCE REQUIREMENTS WITH "LOW BACK"

NOTE: A 36-inch minimum clearance is required between the top of the cooking surface and the bottom of an unprotected cabinet. A 30-inch clearance can be used when the bottom of the wood or metal cabinet is protected by not less than 1/4 inch of a flame retardant material covered with not less than No. 28 MSG sheet steel, 0.015 inch (0.4 mm) thick stainless steel, 0.024 inch (0.6 mm) aluminum, or 0.020 inch (0.5 mm) thick copper.

△ As defined in the "National Fuel Gas Code" (ANSI Z223.1, Current Edition). Clearances from non-combustible materials are not part of the ANSI Z21.1 scope and are not certified by CSA. Clearances of less than 12" (305 mm) must be approved by the local codes and/or by the local authority having jurisdiction.

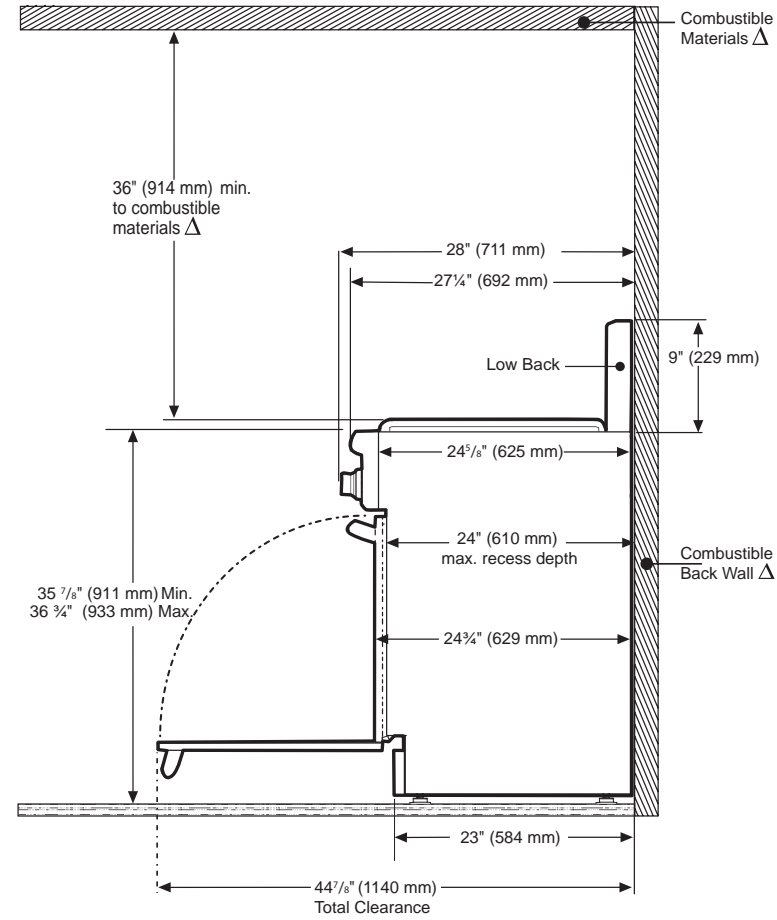

30-INCH (4-BURNER MODELS), 36-INCH & 48-INCH PRO HARMONY RANGE DIMENSIONS AND CLEARANCE REQUIREMENTS WITH "FLUSH ISLAND TRIM"

△ As defined in the "National Fuel Gas Code" (ANSI Z223.1, Current Edition). Clearances from non-combustible materials are not part of the ANSI Z21.1 scope and are not certified by CSA. Clearances of less than 12" (305 mm) must be approved by the local codes and/or by the local authority having jurisdiction.

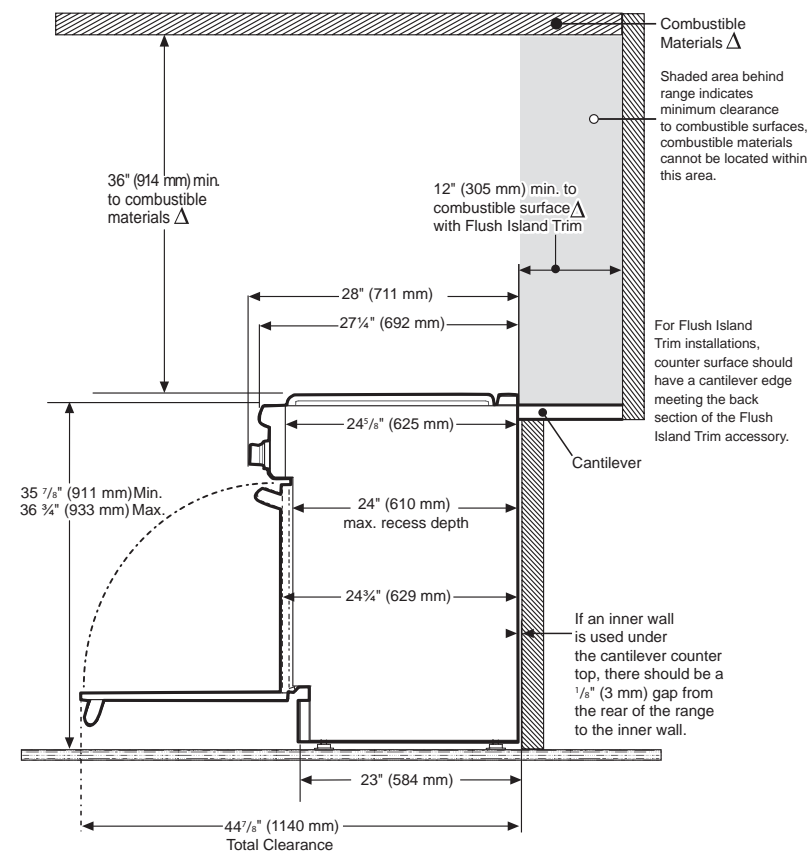

MODEL SHOWN: PRD486GDHU PRO HARMONY RANGE.
KITCHEN DESIGN BY: JENNIFER ALLISON, JENNIFER ALLISON DESIGN



Thermador 

RANGETOPS

PROFESSIONAL SERIES

Thermador Professional® Rangetops feature a unique combination of industry leading design and unrivaled performance—the hallmark of a true Thermador appliance.

Thanks to the power of our fourth generation pedestal Star® Burner, this design boasts unparalleled heat distribution and flame control. The exclusive burner pedestal with QuickClean Base® allows for easy access under the burner for effortless cleaning. All rangetops offer two ExtraLow® burners for simmering delicate sauces, and each burner is rated at 18,000 BTU / hr for the ultimate in cooking power.



Professional Rangetops FEATURE HIGHLIGHTS

★ QUICKCLEAN BASE®

The raised pedestal burner and porcelain maintop have been crafted for perfect integration and easy cleanup. A teardrop emboss reduces food buildup near the base.

★ EXTRALOW® SIMMER

Our ExtraLow feature provides the widest variety of temperature control of any simmer system. Cycling on and off, each Star Burner® can maintain temperatures as low as 100°, a must-have option for cooks who demand perfection when preparing delicate sauces, melted cheeses, or even sugary confections. Each Thermador Pro Rangetop features two ExtraLow burners.

★ OUR EXCLUSIVE, PATENTED STAR® BURNER

The Star Burner's unique shape isn't just for show. It creates a perimeter 56% longer than a round burner, which allows the inclusion of more flame ports. The result is a burner that delivers superior flame spread and a reduced cold spot for faster and more even heating across any size pan.

★ STAR-K CERTIFIED

Thermador Professional® Rangetops are Star-K certified making it possible to use them on the Sabbath or the Holidays.



★ FASTEST TIME TO BOIL

Our Star® Burner's 18,000 BTU / hr of output and superior heat distribution boils water in a fraction of the time of a conventional range or cooktop and over 50% faster than leading competitors.

★ THERMADOR® EXCLUSIVE

★ 5 BURNERS, 30-INCH DESIGN, ZERO CLEARANCE

Our Professional Rangetop delivers the ultimate in convenience and performance with the luxury of 5 Star® burners in a 30-inch design. The powerful burners fire up to 59,000 BTUs yet only require 300 CFM venting thanks to an innovative technology that reduces back wall temperatures by as much as 25%.* This allows you to install the rangetop flush against a kitchen wall with zero clearance for complete design flexibility.

*When compared to professional ranges with traditional BTU output

★ INDOOR ELECTRIC PRO GRILL WITH CERAMIC BRIQUETTES

Our easy-to-clean, indoor grilling feature boasts industry-leading design, featuring ceramic briquettes and fusion coated grill plates that fully cover the heating elements to offer exceptional grilling performance with genuine smoky flavor while minimizing flare-ups. 2 heating zones let you control the front and back zones independently.

★ MULTIPLE CONFIGURATIONS

Configure the rangetop to match the way you cook, by adding a removable 12-inch electric griddle or an optional grill accessory. Both feature a non-stick, rust-proof cast-aluminum fusion coated surface that is dishwasher-safe for easy cleanup.

★ 18,000 BTU / HR ON EVERY BURNER*

Delivers superior cooking flexibility by offering maximum heat output on every burner. Leading competitors offer only one or two powerful burners.

*Except model PCG305P

★ THERMADOR® EXCLUSIVE



Star Burner: 50 ports / 16 3/4" perimeter

Conventional Burner: 28 ports / 10 3/4" perimeter

PCG305P

30-INCH GAS RANGETOP

PROFESSIONAL SERIES, PORCELAIN COOKTOP SURFACE



FEATURES & BENEFITS

- ★ - Patented Pedestal Star® Burner with QuickClean Base® designed for easy surface cleaning and superior heat spread for any size pan
- ★ - Precision simmering capabilities as low as 100°F (375 BTU) with 2 ExtraLow® Simmer burners
- Five Star® Burners with an overall output of 59,000 BTU (NG)
- Star-K certified
- Restaurant style metal knobs

ACCESSORIES (OPTIONAL)

- PAGRIDDLE Griddle
- PA12CHPBLK 12" Cutting Board
- PWOKRINGHC Wok Ring
- PA30GLBC 12" Low Backguard
- PAKNOBLUNH Blue Knob Kit
- PALPKITHP LP Conversion Kit

GENERAL PROPERTIES

Controls	Metal Knobs
Sealed Burners	Yes
Grate Material	Cast Iron

BURNER PERFORMANCE

Total Number Of Cooktop Burners	5
Power of Front Left Burner (NG)	10,000
Power of Back Left Burner (NG)	8,000 and XLO
Power of Back Center Burner (NG)	15,000
Power of Front Center Burner (NG)	N/A
Power Of Center 12" Electric Griddle (W)	N/A
Power Of Center 12" Electric Grill (W)	N/A
Power of Back Right Burner (NG)	8,000
Power of Front Right Burner (NG)	18,000 and XLO

TECHNICAL DETAILS

Circuit Breaker (A)	10 A
Volts (V)	120 V
Frequency (Hz)	60 Hz
Plug Type	120V-3 Prong
Power Cord Length (in)	72"
Energy Source	Gas
Gas Type	Natural Gas 15 mbar (USA)
Alternative Gas Type	LP 27.4 mbar (USA)
Convertible To LP (Kit Required)	Yes

DIMENSIONS & WEIGHT

Overall Appliance Dimensions (H*xWxD) (in)	10 9/16" x 29 15/16" x 25 13/16"
Required Cutout Size (HxWxD) (in)	7 11/16" x 29 1/8" x 22 13/16"
Minimum Distance From Rear Wall (in)	2" min from the rear of the unit to the back of the wall
Net Weight (lbs)	122 lbs

ACCESSORIES (INCLUDED)

1 x Island Trim

WARRANTY

Limited Warranty, Entire Appliance, Parts and Labor	2 Year
---	--------

*Height Includes Gas Connection

PCG364GD

36-INCH GAS RANGETOP WITH GRIDDLE

PROFESSIONAL SERIES, PORCELAIN COOKTOP SURFACE



FEATURES & BENEFITS

- ★ - Patented Pedestal Star® Burner with QuickClean Base® designed for easy surface cleaning and superior heat spread for any size pan
- ★ - Precision simmering capabilities as low as 100°F (375 BTU) with 2 ExtraLow® Simmer burners
- 18,000 BTU (NG) Star® Burners
- Superior griddle results—6 pass, 1,630 Watt electric griddle
- Non-stick, rust-proof cast-aluminum griddle and grill with fusion coated surface, removable for easy cleanup

ACCESSORIES (OPTIONAL)

- PA12GRILLN Pro Grill
- PAGRIDDLE Griddle
- PA12CVRJ 12" Grill / Griddle Cover
- PA12CHPBLK 12" Cutting Board
- PWOKRINGHC Wok Ring
- PA36GLBC 12" Low Backguard
- PAKNOBLUNH Blue Knob Kit
- PALPKITHN LP Conversion Kit

GENERAL PROPERTIES

Controls	Metal Knobs
Sealed Burners	Yes
Grate Material	Cast Iron

BURNER PERFORMANCE

Total Number of Cooktop Burners	4
Power of Front Left Burner (NG)	18,000 and XLO
Power of Back Left Burner (NG)	18,000 and XLO
Power of Back Center Burner (NG)	N/A
Power of Front Center Burner (NG)	N/A
Power of Center 12" Electric Griddle (W)	1,630 W
Power of Center 12" Electric Grill (W)	N/A
Power of Back Right Burner (NG)	18,000
Power of Front Right Burner (NG)	18,000

TECHNICAL DETAILS

Circuit Breaker (A)	15 A
Volts (V)	120 V
Frequency (Hz)	60 Hz
Plug Type	120V-3 Prong
Power Cord Length (in)	72"
Energy Source	Gas
Gas Type	Natural Gas 15 mbar (USA)
Alternative Gas Type	LP 27.4 mbar (USA)
Convertible To LP (Kit Required)	Yes

DIMENSIONS & WEIGHT

Overall Appliance Dimensions (H*xWxD) (in)	10 9/16" x 35 15/16" x 25 13/16"
Required Cutout Size (HxWxD) (in)	7 11/16" x 35 1/8" x 22 13/16"
Minimum Distance From Rear Wall (in)	12" min to combustible surface with Flush Island Trim
Net Weight (lbs)	155 lbs

ACCESSORIES (INCLUDED)

1 x Island Trim

WARRANTY

Limited Warranty, Entire Appliance, Parts and Labor	2 Year
---	--------

*Height Includes Gas Connection

PCG364NL

36-INCH GAS RANGETOP WITH GRILL

PROFESSIONAL SERIES, PORCELAIN COOKTOP SURFACE



FEATURES & BENEFITS

- ★ - Patented Pedestal Star® Burner with QuickClean Base® designed for easy surface cleaning and superior heat spread for any size pan
- ★ - Precision simmering capabilities as low as 100°F (375 BTU) with 2 ExtraLow® Simmer burners
 - 18,000 BTU (NG) Star® Burners
 - Superior grill results—1,630 Watt indoor electric grill
 - Non-stick, rust-proof cast-aluminum grill with fusion coated surface, removable for easy cleanup

ACCESSORIES (OPTIONAL)



PABRICKBN
Black Ceramic Briquettes with Basket



PA12LCVRN
12" Pro Grill Cover for Indoor Electric Grill



PAGRIDDLEN
12" Pro Griddle



PAGRIDDLE
Griddle



PA12CHPBLK
12" Cutting Board



PWOKRINGHC
Wok Ring



PA36GLBC
12" Low Backguard



PAKNOBLUNH
Blue Knob Kit



PALPKITHN
LP Conversion Kit

GENERAL PROPERTIES

Controls	Metal Knobs
Sealed Burners	Yes
Grate Material	Cast Iron

BURNER PERFORMANCE

Total Number of Cooktop Burners	4
Power of Front Left Burner (NG)	18,000 and XLO
Power of Back Left Burner (NG)	18,000 and XLO
Power of Back Center Burner (NG)	N/A
Power of Front Center Burner (NG)	N/A
Power of Center 12" Electric Griddle (W)	N/A
Power of Center 12" Electric Grill (W)	1,630 W
Power of Back Right Burner (NG)	18,000
Power of Front Right Burner (NG)	18,000

TECHNICAL DETAILS

Circuit Breaker (A)	20 A
Volts (V)	120 V
Frequency (Hz)	60 Hz
Plug Type	120V-3 Prong NEMA 5-20
Power Cord Length (in)	72"
Energy Source	Gas
Gas Type	Natural Gas 15 mbar (USA)
Alternative Gas Type	LP 27.4 mbar (USA)
Convertible To LP (Kit Required)	Yes

DIMENSIONS & WEIGHT

Overall Appliance Dimensions (H*xWxD) (in)	10 9/16" x 35 15/16" x 25 13/16"
Required Cutout Size (HxWxD) (in)	7 11/16" x 35 1/8" x 22 13/16"
Minimum Distance From Rear Wall (in)	12" min to combustible surface with Flush Island Trim
Net Weight (lbs)	155 lbs

ACCESSORIES (INCLUDED)

1 x Island Trim

WARRANTY

Limited Warranty, Entire Appliance, Parts and Labor	2 Year
---	--------

*Height Includes Gas Connection

PCG366G

36-INCH GAS RANGETOP

PROFESSIONAL SERIES, PORCELAIN COOKTOP SURFACE



FEATURES & BENEFITS

- ★ - Patented Pedestal Star® Burner with QuickClean Base® designed for easy surface cleaning and superior heat spread for any size pan
- ★ - Precision simmering capabilities as low as 100°F (375 BTU) with 2 ExtraLow® Simmer burners
 - 18,000 BTU (NG) Star® Burners
 - Star-K certified
 - Restaurant style metal knobs

ACCESSORIES (OPTIONAL)



PAGRIDDLE
Griddle



PA12CHPBLK
12" Cutting Board



PWOKRINGHC
Wok Ring



PA36GLBC
12" Low Backguard



PAKNOBLUNH
Blue Knob Kit



PALPKITHN
LP Conversion Kit

GENERAL PROPERTIES

Controls	Metal Knobs
Sealed Burners	Yes
Grate Material	Cast Iron

BURNER PERFORMANCE

Total Number of Cooktop Burners	6
Power of Front Left Burner (NG)	18,000 and XLO
Power of Back Left Burner (NG)	18,000 and XLO
Power of Back Center Burner (NG)	18,000
Power of Front Center Burner (NG)	18,000
Power of Center 12" Electric Griddle (W)	N/A
Power of Center 12" Electric Grill (W)	N/A
Power of Back Right Burner (NG)	18,000
Power of Front Right Burner (NG)	18,000

TECHNICAL DETAILS

Circuit Breaker (A)	10 A
Volts (V)	120 V
Frequency (Hz)	60 Hz
Plug Type	120V-3 Prong
Power Cord Length (in)	72"
Energy Source	Gas
Gas Type	Natural Gas 15 mbar (USA)
Alternative Gas Type	LP 27.4 mbar (USA)
Convertible To LP (Kit Required)	Yes

DIMENSIONS & WEIGHT

Overall Appliance Dimensions (H*xWxD) (in)	10 9/16" x 35 15/16" x 25 13/16"
Required Cutout Size (HxWxD) (in)	7 11/16" x 35 1/8" x 22 13/16"
Minimum Distance From Rear Wall (in)	12" min to combustible surface with Flush Island Trim
Net Weight (lbs)	142 lbs

ACCESSORIES (INCLUDED)

1 x Island Trim

WARRANTY

Limited Warranty, Entire Appliance, Parts and Labor	2 Year
---	--------

*Height Includes Gas Connection

PCG486GD

48-INCH GAS RANGETOP WITH GRIDDLE

PROFESSIONAL SERIES, PORCELAIN COOKTOP SURFACE



GENERAL PROPERTIES	
Controls	Metal Knobs
Sealed Burners	Yes
Grate Material	Cast Iron

BURNER PERFORMANCE	
Total Number of Cooktop Burners	6
Power of Front Left Burner (NG)	18,000 and XLO
Power of Back Left Burner (NG)	18,000 and XLO
Power of Back Center Burner (NG)	18,000
Power of Front Center Burner (NG)	18,000
Power of Center 12" Electric Griddle (W)	1,630 W
Power of Center 12" Electric Grill (W)	N/A
Power of Back Right Burner (NG)	18,000
Power of Front Right Burner (NG)	18,000

TECHNICAL DETAILS	
Circuit Breaker (A)	15 A
Volts (V)	120 V
Frequency (Hz)	60 Hz
Plug Type	120V-3 Prong
Power Cord Length (in)	72"
Energy Source	Gas
Gas Type	Natural Gas 15 mbar (USA)
Alternative Gas Type	LP 27.4 mbar (USA)
Convertible To LP (Kit Required)	Yes

DIMENSIONS & WEIGHT	
Overall Appliance Dimensions (H*xWxD) (in)	10 9/16" x 47 15/16" x 25 13/16"
Required Cutout Size (HxWxD) (in)	7 11/16" x 46 1/4" x 22 13/16"
Minimum Distance From Rear Wall (in)	12" min to combustible surface with Flush Island Trim
Net Weight (lbs)	172 lbs

ACCESSORIES (INCLUDED)	
1 x Island Trim	

WARRANTY	
Limited Warranty, Entire Appliance, Parts and Labor	2 Year

*Height Includes Gas Connection

FEATURES & BENEFITS

- ★ - Patented Pedestal Star® Burner with QuickClean Base® designed for easy surface cleaning and superior heat spread for any size pan
- ★ - Precision simmering capabilities as low as 100°F (375 BTU) with 2 ExtraLow® Simmer burners
- 18,000 BTU (NG) Star® Burners
- Superior griddle results—6 pass, 1,630 Watt electric griddle
- Non-stick, rust-proof cast-aluminum griddle and grill with fusion coated surface, removable for easy cleanup

ACCESSORIES (OPTIONAL)

- PA12GRILLN Pro Grill
- PA12CVRJ 12" Grill / Griddle Cover
- PAGRIDDLE Griddle
- PA12CHPBLK 12" Cutting Board
- PWOKRINGHC Wok Ring
- PA48GLBC 12" Low Backguard
- PAKNOBLUNH Blue Knob Kit
- PALPKITHN LP Conversion Kit

PCG486NL

48-INCH GAS RANGETOP WITH GRILL

PROFESSIONAL SERIES, PORCELAIN COOKTOP SURFACE



GENERAL PROPERTIES	
Controls	Metal Knobs
Sealed Burners	Yes
Grate Material	Cast Iron

BURNER PERFORMANCE	
Total Number of Cooktop Burners	6
Power of Front Left Burner (NG)	18,000 and XLO
Power of Back Left Burner (NG)	18,000 and XLO
Power of Back Center Burner (NG)	18,000
Power of Front Center Burner (NG)	18,000
Power of Center 12" Electric Griddle (W)	N/A
Power of Center 12" Electric Grill (W)	1,630 W
Power of Back Right Burner (NG)	18,000
Power of Front Right Burner (NG)	18,000

TECHNICAL DETAILS	
Circuit Breaker (A)	20 A
Volts (V)	120 V
Frequency (Hz)	60 Hz
Plug Type	120V-3 Prong NEMA 5-20
Power Cord Length (in)	72"
Energy Source	Gas
Gas Type	Natural Gas 15 mbar (USA)
Alternative Gas Type	LP 27.4 mbar (USA)
Convertible To LP (Kit Required)	Yes

DIMENSIONS & WEIGHT	
Overall Appliance Dimensions (H*xWxD) (in)	10 9/16" x 47 15/16" x 25 13/16"
Required Cutout Size (HxWxD) (in)	7 11/16" x 46 1/4" x 22 13/16"
Minimum Distance From Rear Wall (in)	12" min to combustible surface with Flush Island Trim
Net Weight (lbs)	172 lbs

ACCESSORIES (INCLUDED)	
1 x Island Trim	

WARRANTY	
Limited Warranty, Entire Appliance, Parts and Labor	2 Year

*Height Includes Gas Connection

FEATURES & BENEFITS

- ★ - Patented Pedestal Star® Burner with QuickClean Base® designed for easy surface cleaning and superior heat spread for any size pan
- ★ - Precision simmering capabilities as low as 100°F (375 BTU) with 2 ExtraLow® Simmer burners
- 18,000 BTU (NG) Star® Burners
- Superior grill results, 1,630 Watt indoor electric grill
- Non-stick, rust-proof cast-aluminum grill with fusion coated surface, removable for easy cleanup

ACCESSORIES (OPTIONAL)

- PABRICKBKN Black Ceramic Briquettes with Basket
- PA12LCVRN 12" Pro Grill Cover for Indoor Electric Grill
- PAGRIDDLEN 12" Pro Griddle
- PAGRIDDLE Griddle
- PA12CHPBLK 12" Cutting Board
- PWOKRINGHC Wok Ring
- PA48GLBC 12" Low Backguard
- PAKNOBLUNH Blue Knob Kit
- PALPKITHN LP Conversion Kit

PROFESSIONAL RANGETOPS

PLANNING INFORMATION

MODEL OPTIONS

There are three sizes of Thermador Professional® Rangetops to choose from—30-inch, 36-inch and 48-inch. 36-inch rangetops are available with two choices of rangetop configurations. Every model ships standard with an Island Trim. Every model is LP convertible by ordering PALPKITHC. Be sure to reference the correct model information in this design guide.

INSTALLATION CONSIDERATIONS

The information in this design guide provides key features, product dimensions, cutouts and installation specifications. Before installing a Thermador Professional® Rangetop, be sure to verify the cutout dimensions and electrical / gas connections. Also, always consult with the installation manual packed with the product for complete details before installing.

Thermador Professional® Rangetops may be installed above a Thermador Warming Drawer to create a convenient cooking center. A minimum 2 3/4" clearance is required between the bottom of the rangetop and the top of the warming drawer. Refer to the warming drawer section for additional specifications.

INSTALLATION OPTIONS

To ensure professional results, the cabinet and countertop openings should be prepared by a qualified cabinet worker. The rangetop can be installed in various positions with the front either flush or projecting, depending on the countertop's depth. The rangetop is designed to hang from the countertop by its side flanges. The countertop however, must be strong enough to support the rangetop. It may be necessary to add a supporting cleat along each side or a 2" x 4" corner brace. Another alternative would be to construct a deck to set the rangetop on. Consult with the installation manual packed with the product for complete details before installing.

ABOVE A WARMING DRAWER

Thermador Professional® Rangetops may be installed above a Thermador Warming Drawer to create a convenient cooking center. A minimum 2 3/4" clearance is required between the bottom of the rangetop and the top of the warming drawer. Refer to the warming drawer section for additional specifications.

BACKGUARDS

When using the Flush Island Trim, Thermador recommends a minimum 12" (305 mm) rear clearance to a combustible surface (see Figure 1, Cabinet Clearances). Clearances from non-combustible materials are not part of the ANSI Z21.1 scope and are not certified by CSA. Clearances of less than 12" (305 mm) must be approved by the local codes and / or by the local authority having jurisdiction. (Model PCG305P excluded)

ELECTRICAL AND GAS SPECIFICATIONS

Be sure your appliance is properly installed and grounded by a qualified technician. Installation, electrical and gas connections, and grounding must comply with all applicable local codes.

Thermador Professional® Rangetops are equipped with a 3-wire plug and are designed to be connected to a 120V AC, 60 Hz, single-phase power supply. A dedicated circuit breaker is required.

MODEL	REQUIRED CIRCUIT BREAKER
	120V AC, 60Hz
PCG305P	10 A
PCG364GD	15 A
PCG364NL	20 A
PCG366G	10 A
PCG486GD	15 A
PCG486NL	20 A

GAS REQUIREMENTS AND HOOKUP

Rangetops are shipped by the factory to operate on natural gas. They must be converted for use with propane. Verify that the type of gas being used at the installation site matches the type of gas used by the appliance. If the location / job site requires conversion from natural gas to propane (LP), order an LP kit. Field conversion must be done by qualified service personnel only. Please refer to the LP Conversion Instructions for further information.

A manual gas shut-off valve must be installed external to the appliance, in a location accessible from the front, for the purpose of shutting off the gas supply. The supply line must not interfere with the back of the unit.

NATURAL GAS OR LP

Thermador Professional® Rangetops are shipped by the factory to operate on natural gas. They must be converted for use with propane. Verify the type of gas being used at the installation site matches the type of gas used by the appliance. If the location / job site requires conversion from natural gas to propane (LP), order PALPKITHP (model PCG305P) or PALPKITHN (all 36" and 48" models). Field conversion must be done by qualified service personnel only. Please refer to the LP Conversion Instructions packed with product for further information.

ELECTRICAL SUPPLY

IMPORTANT: The cord supplied with gas rangetops having a grill requires a NEMA 5-20 receptacle as shown here. Local codes may require a different wiring method.

NEMA 5-20 RECEPTACLE



PLUG

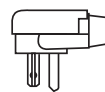

WARNING: This appliance is equipped with a three-prong grounding plug for protection against shock hazard and should be plugged directly into a properly grounded receptacle. DO NOT cut or remove the grounding prong from this plug. DO NOT ALTER THIS PLUG.

VENTILATION REQUIREMENTS

We strongly recommend that a Thermador Professional® Wall or Island Hood or Custom Insert be installed with all Thermador Professional® Rangetops. Downdraft ventilation should not be used. Do not install a microwave-hood combination above the rangetop, as these types of units do not provide the proper ventilation and are not suitable for use with Thermador Professional® Rangetops.

For high output gas cooktops or rangetops (60,000 BTU or greater), the minimum of one (1) CFM of ventilation per 100 BTU is recommended. If the cooktop or rangetop has a grill or griddle, add 150 CFM to the estimated blower capacity. Additional blower capacity may be required for longer duct runs.

The following table indicates the ventilation hood options and blower capacity guidelines that are recommended for use with Thermador Professional® Rangetops. Refer to the Ventilation section or www.thermador.com for a complete selection of Professional ventilation options, blowers, and accessories.

WIDTH	CONFIGURATION	VENTILATION OPTIONS
30"	5 Burners	30" or 36" Pro Wall Hood 42" Island Hood 30" Custom Insert
36"	4 Burners	36" Pro Wall Hood 36" Chimney Wall Hood 42" Island Hood 36" Custom Insert
36"	6 Burners	36" Pro Wall Hood 36" Chimney Wall Hood 42" Island Hood 36" Custom Insert
48"	6 Burners	48" or 54" Pro Wall Hood 48" Chimney Wall Hood 48" Island Hood 48" or 54" Custom Insert

IMPORTANT VENTILATION NOTES:

- Due to high surface temperature output (excluding model PCG305P), the HPWB Professional Series Wall Hoods or the Professional Custom Inserts are recommended ventilation solutions for these rangetops. The PH Professional Series Wall Hoods are also a viable option.
- For wall installations, the hood width must, at a minimum, equal the nominal width of the appliance cooking surface. Where space permits, a hood larger in width than the cooking surface may be desirable for improved ventilation performance.

PROFESSIONAL RANGETOPS

PLANNING INFORMATION



- For island installations the hood width should, at a minimum, overhang the appliance cooking surface by 3" on each side.
- Due to the high heat capability of these rangetops, particular attention should be paid to the hood and duct work installation to assure it meets local building codes.
- For best smoke elimination, the lower edge of the hood should be installed 30" above the appliance cooking surface.
- If the hood contains any combustible materials (i.e., a wood covering), it must be 36" or greater distance above the cooking surface.

PROFESSIONAL RANGETOPS INSTALLATION

30-INCH RANGETOP AND CUTOUT DIMENSIONS

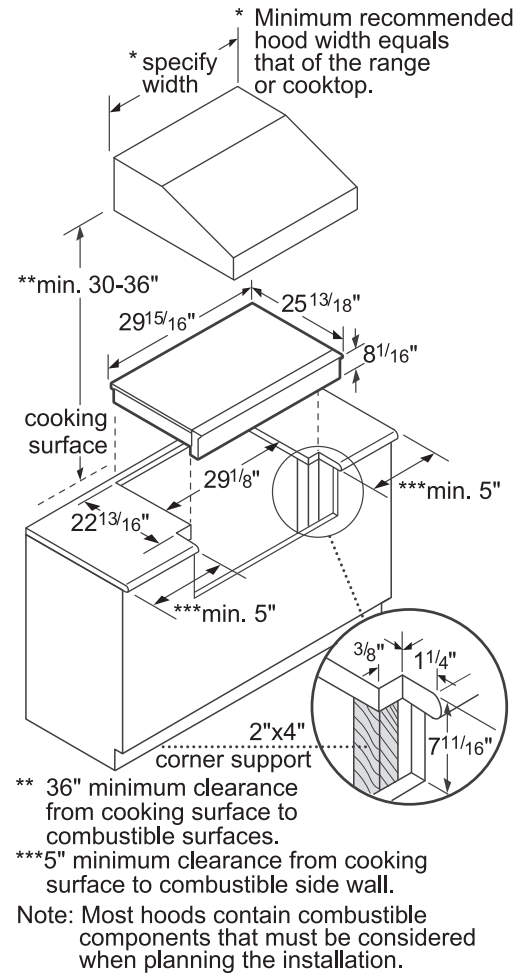

measurements in inches

30-INCH SIDE VIEW OF RANGETOP

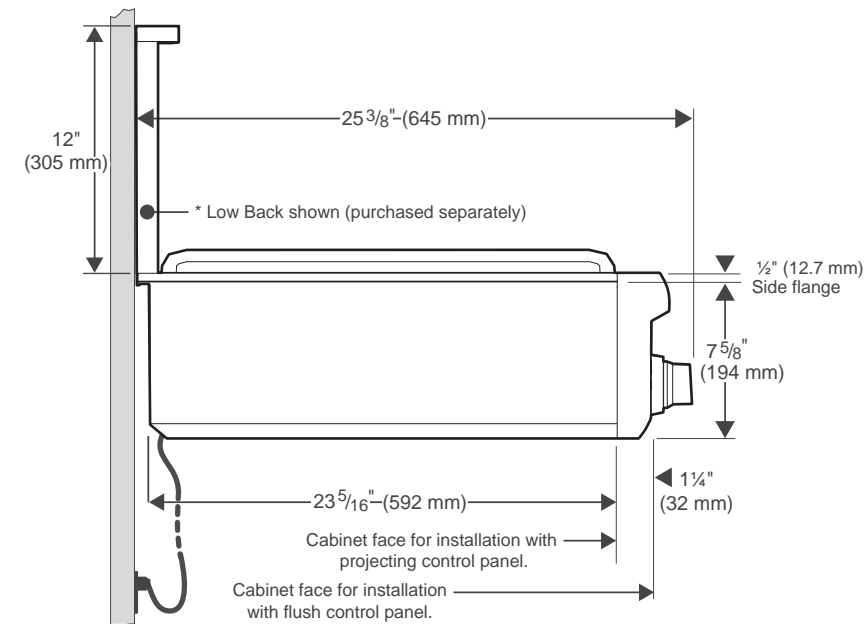

30-INCH PROJECTING FROM CABINET FRONT

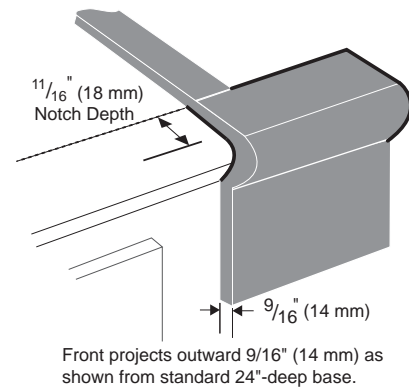

30-INCH FLUSH TO CABINET FRONT

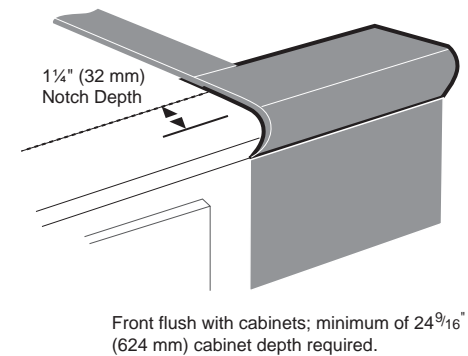

30-INCH RANGETOP CABINET CLEARANCES WITH HOOD

NOTE: A 36-inch minimum clearance is required between the top of the cooking surface and the bottom of an unprotected cabinet. A 30-inch clearance can be used when the bottom of the wood or metal cabinet is protected by not less than 1/4 inch of a flame retardant material covered with not less than No. 28 MSG sheet steel, 0.015 inch (0.4 mm) thick stainless steel, 0.024 inch (0.6 mm) aluminum, or 0.020 inch (0.5 mm) thick copper.

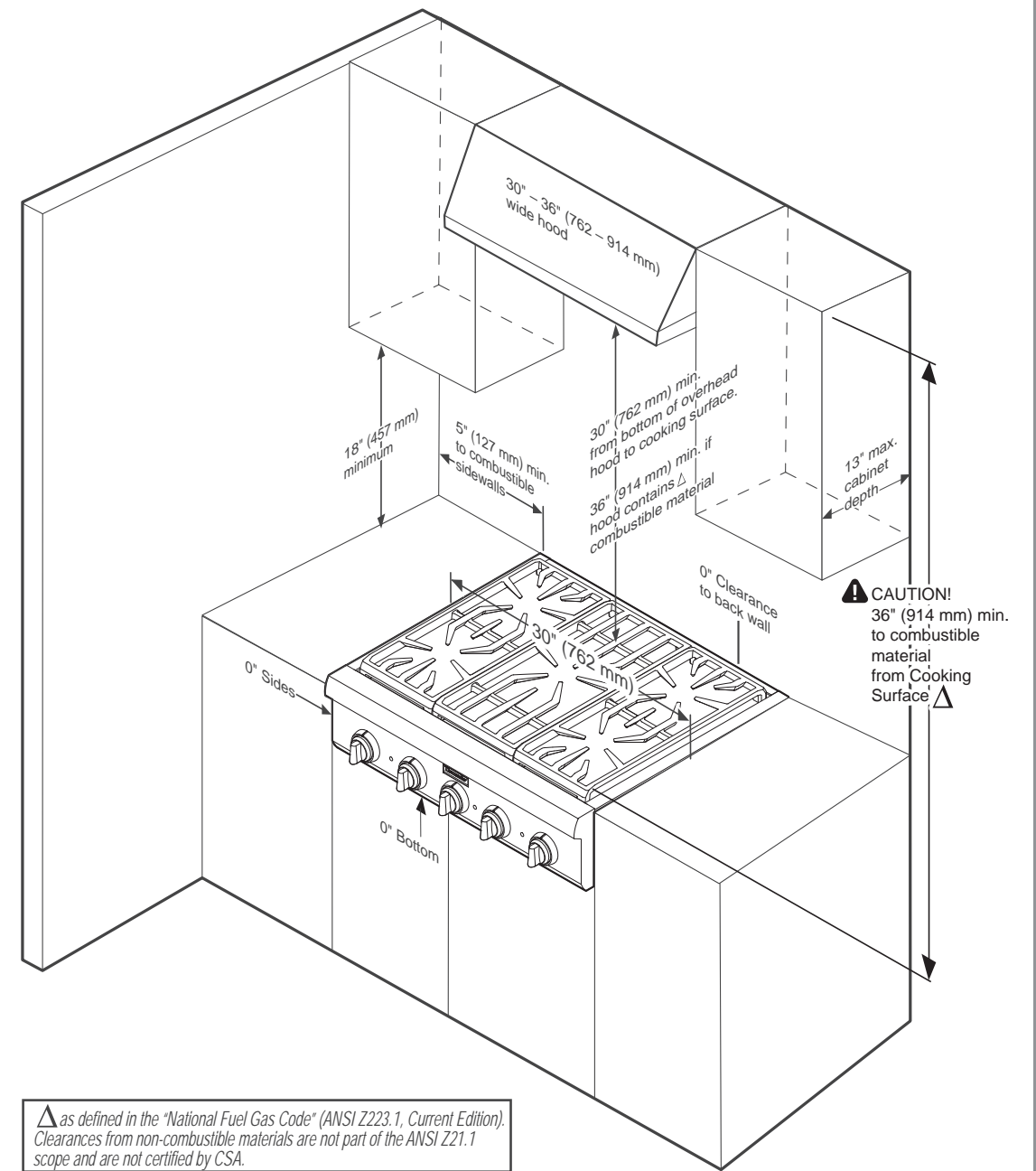

PROFESSIONAL RANGETOPS INSTALLATION

30-INCH RANGETOP CABINET CLEARANCES WITH OVER-THE-RANGE MICROWAVE

NOTE: A 36-inch minimum clearance is required between the top of the cooking surface and the bottom of an unprotected cabinet. A 30-inch clearance can be used when the bottom of the wood or metal cabinet is protected by not less than 1/4 inch of a flame retardant material covered with not less than No. 28 MSG sheet steel, 0.015 inch (0.4 mm) thick stainless steel, 0.024 inch (0.6 mm) aluminum, or 0.020 inch (0.5 mm) thick copper.

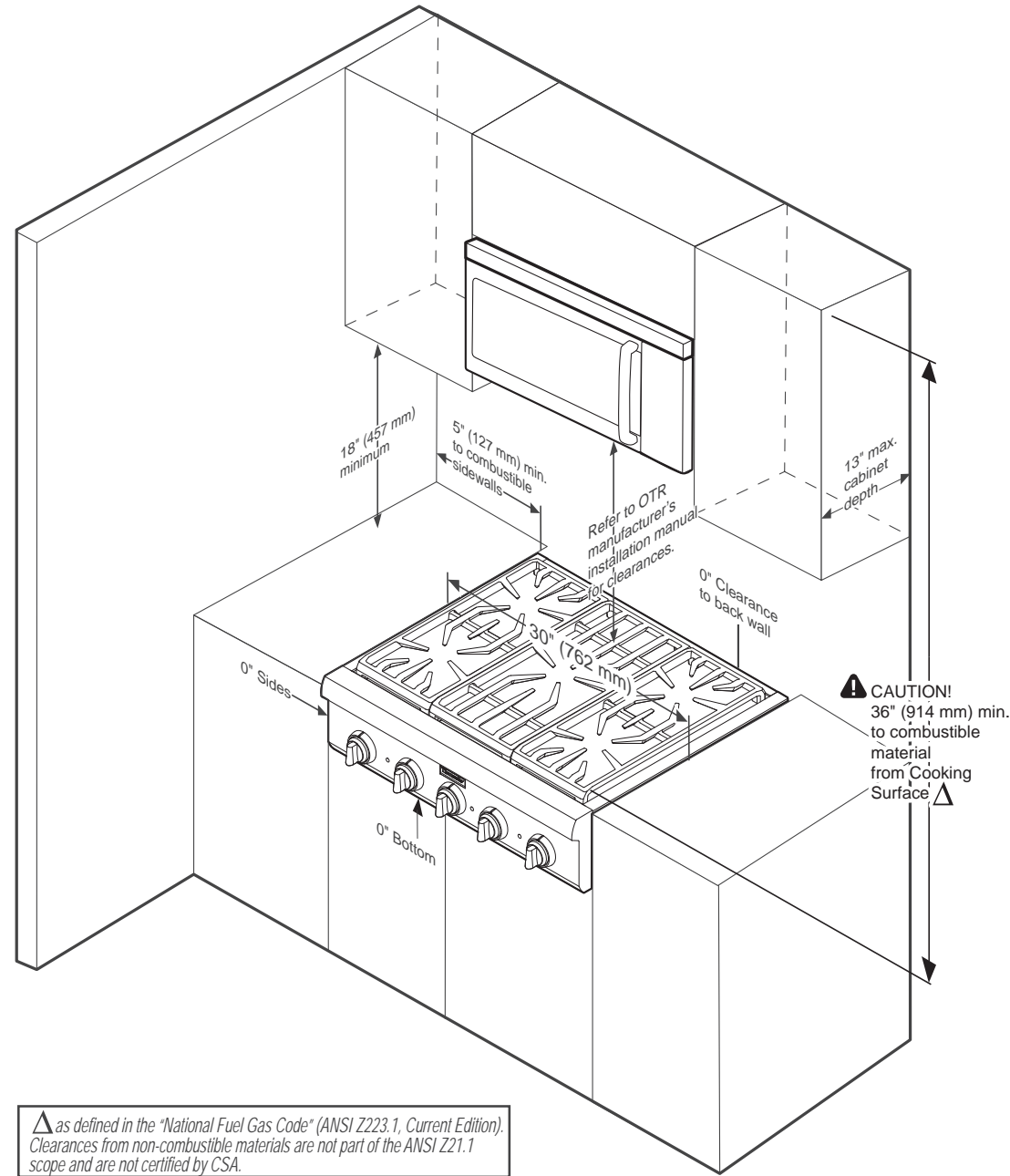

△ as defined in the "National Fuel Gas Code" (ANSI Z223.1, Current Edition). Clearances from non-combustible materials are not part of the ANSI Z21.1 scope and are not certified by CSA.

PROFESSIONAL RANGETOPS INSTALLATION

30-INCH ELECTRICAL AND GAS LOCATIONS

The gas and electrical supply must be located in an area that is accessible without requiring removal of the rangetop. The appliance electrical power cord and gas pipe connection are located on the left rear underside of the rangetop.

The junction box must be located within 3 feet (~900 mm) of the rangetop connection.

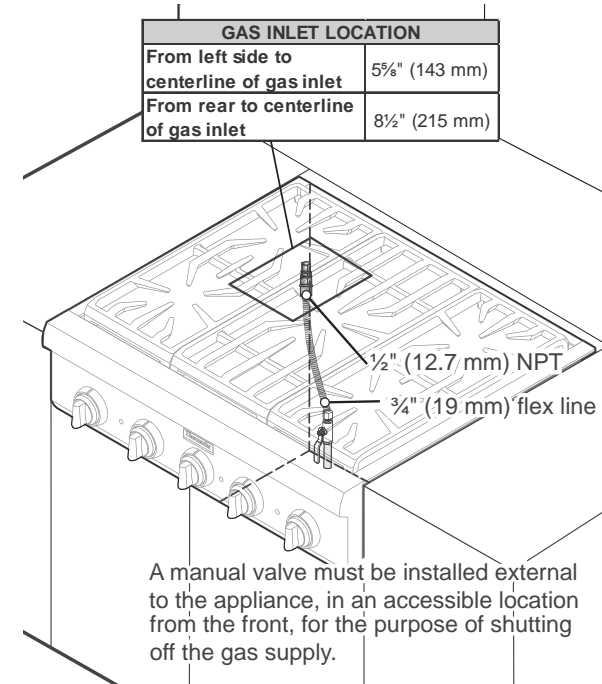

NATURAL GAS REQUIREMENTS:

Inlet Connection: 1/2" NPT (min. 3/4" dia. flex line)
 Supply Pressure: 6" min. to 14" max. water column (14.9 mb to 34.9 mb)
 Manifold Pressure: 5" water column (12.5 mb)

PROPANE GAS REQUIREMENTS:

Inlet Connection: 1/2" NPT (min. 3/4" dia. flex line)
 Supply Pressure: 11" min. to 14" max. water column (27.4 mb to 34.9 mb)
 Manifold Pressure: 10" water column (24.9 mb)

PROFESSIONAL RANGETOPS INSTALLATION

36-INCH RANGETOP AND CUTOUT DIMENSIONS

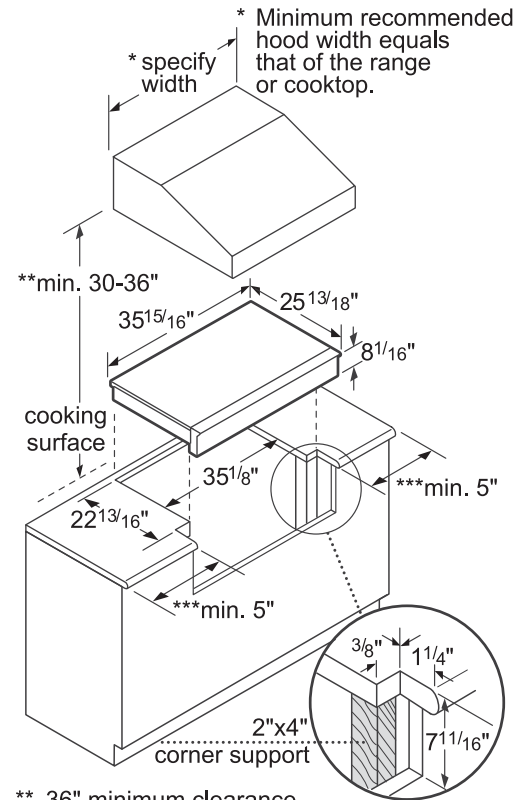

- ** 36" minimum clearance from cooking surface to combustible surfaces.
 - *** 5" minimum clearance from cooking surface to combustible side wall.
 - Note: Most hoods contain combustible components that must be considered when planning the installation.
- measurements in inches

36-INCH ELECTRICAL AND GAS LOCATIONS

The gas and electrical supply must be located in an area that is accessible without requiring removal of the rangetop. The appliance electrical power cord and gas pipe connection are located on the left rear underside of the rangetop.

The junction box must be located within 3 feet (~900 mm) of the rangetop connection.

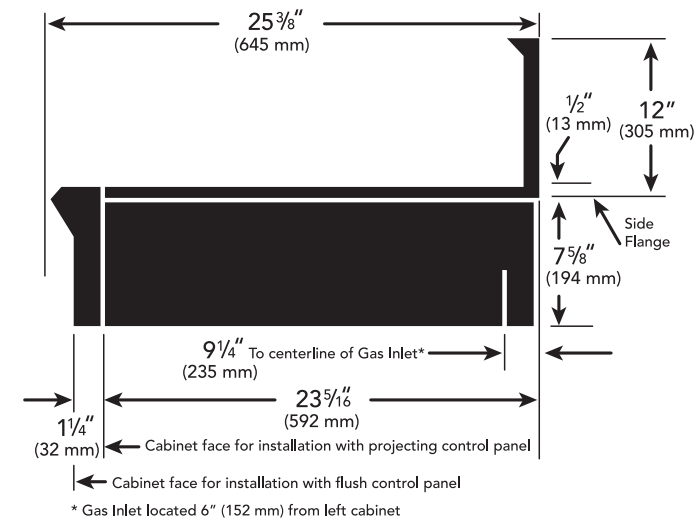

NATURAL GAS REQUIREMENTS:

- Inlet Connection: 1/2" NPT (min. 3/4" dia. flex line)
- Supply Pressure: 6" min. to 14" max. water column (14.9 mb to 34.9 mb)
- Manifold Pressure: 5" water column (12.5 mb)

PROPANE GAS REQUIREMENTS:

- Inlet Connection: 1/2" NPT (min. 3/4" dia. flex line)
- Supply Pressure: 11" min. to 14" max. water column (27.4 mb to 34.9 mb)
- Manifold Pressure: 10" water column (24.9 mb)

PROFESSIONAL RANGETOPS INSTALLATION

36-INCH RANGETOP CLEARANCE REQUIREMENTS

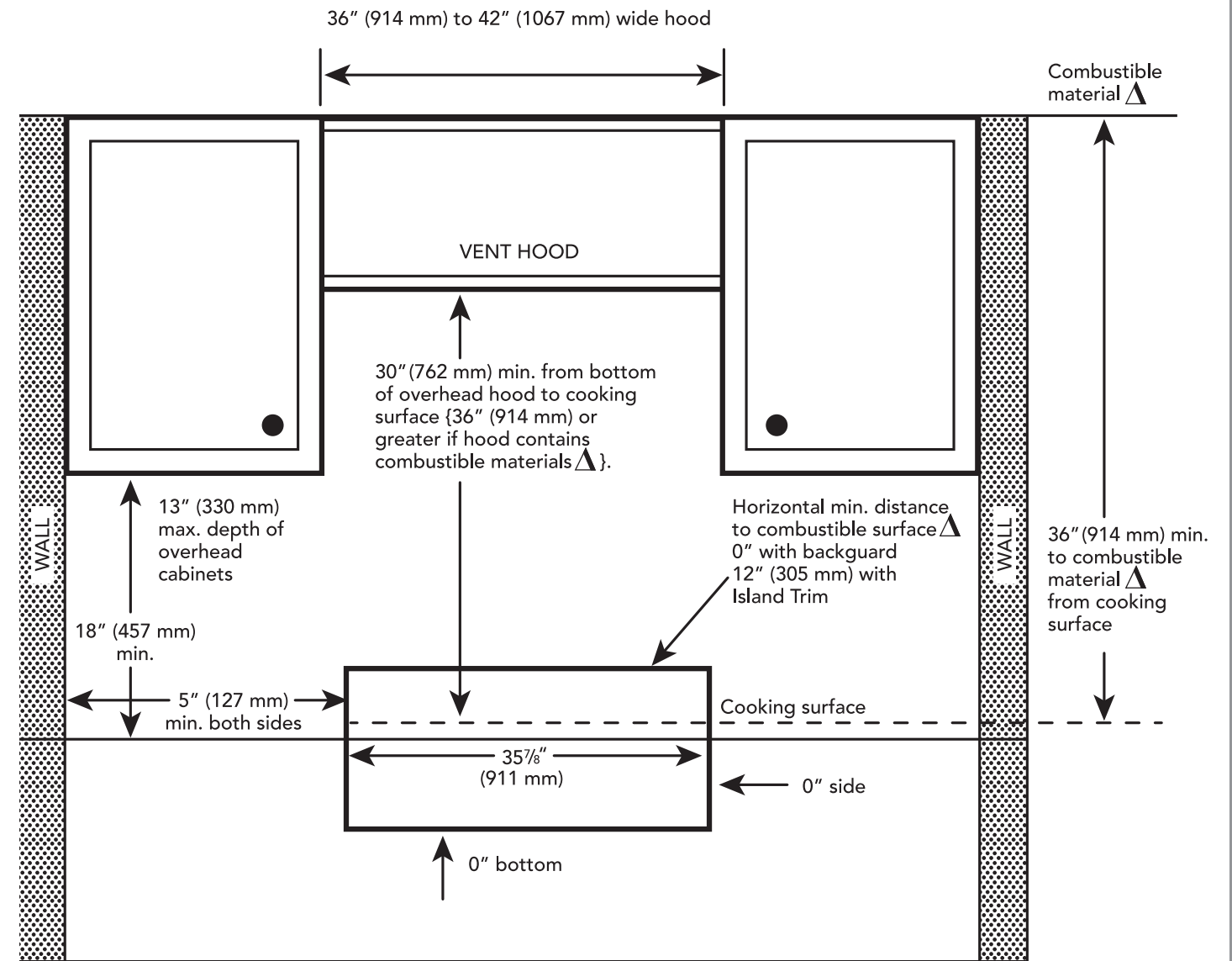

▲ as defined in the "National Fuel Gas Code" (ANSI Z223.1, Current Edition). Clearances from non-combustible materials are not part of the ANSI Z21.1 scope and are not certified by CSA. Clearances of less than 12" (305 mm) must be approved by the local codes and/or by the local authority having jurisdiction.

Clearances Requirements

NOTE: A 36-inch minimum clearance is required between the top of the cooking surface and the bottom of an unprotected cabinet. A 30-inch clearance can be used when the bottom of the wood or metal cabinet is protected by not less than 1/4 inch of a flame retardant material covered with not less than No. 28 MSG sheet steel, 0.015 inch (0.4 mm) thick stainless steel, 0.024 inch (0.6 mm) aluminum, or 0.020 inch (0.5 mm) thick copper.

PROFESSIONAL RANGETOPS INSTALLATION

48-INCH RANGETOP AND CUTOUT DIMENSIONS

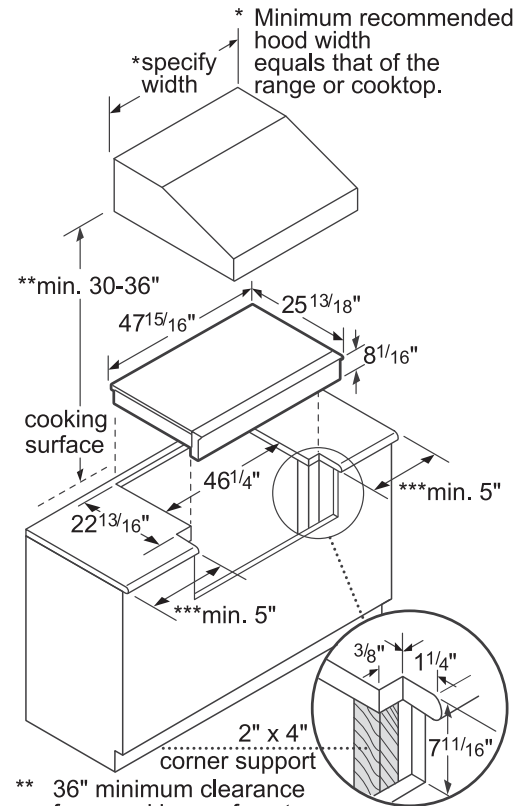

- ** 36" minimum clearance from cooking surface to combustible surfaces.
 - *** 5" minimum clearance from cooking surface to combustible side wall.
- Note: Most hoods contain combustible components that must be considered when planning the installation.

measurements in inches

48-INCH ELECTRICAL AND GAS LOCATIONS

The gas and electrical supply must be located in an area that is accessible without requiring removal of the rangetop. The appliance electrical power cord and gas pipe connection are located on the left rear underside of the rangetop.

The junction box must be located within 3 feet (~900 mm) of the rangetop connection.

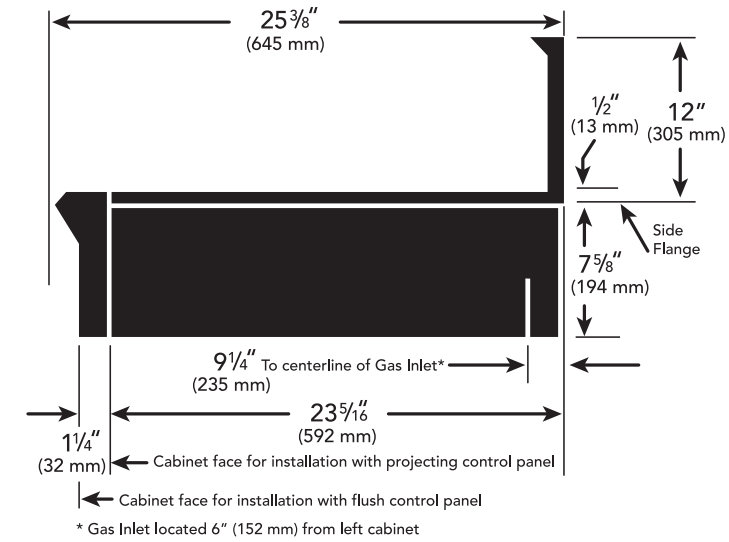

NATURAL GAS REQUIREMENTS:

- Inlet Connection: 1/2" NPT (min. 3/4" dia. flex line)
- Supply Pressure: 6" min. to 14" max. water column (14.9 mb to 34.9 mb)
- Manifold Pressure: 5" water column (12.5 mb)

PROPANE GAS REQUIREMENTS:

- Inlet Connection: 1/2" NPT (min. 3/4" dia. flex line)
- Supply Pressure: 11" min. to 14" max. water column (27.4 mb to 34.9 mb)
- Manifold Pressure: 10" water column (24.9 mb)

PROFESSIONAL RANGETOPS INSTALLATION

48-INCH RANGETOP CLEARANCE REQUIREMENTS

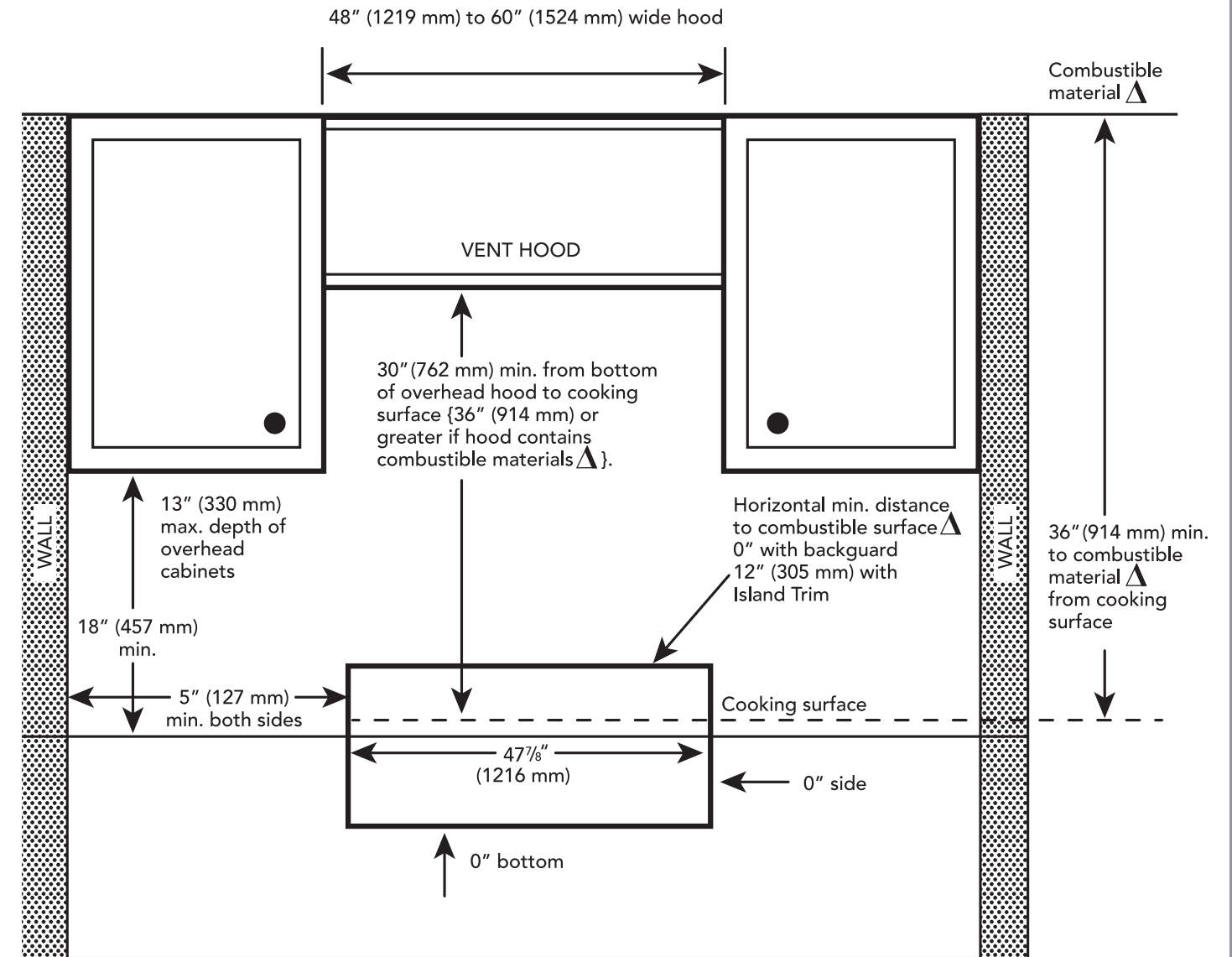

▲ as defined in the "National Fuel Gas Code" (ANSI Z223.1, Current Edition). Clearances from non-combustible materials are not part of the ANSI Z21.1 scope and are not certified by CSA. Clearances of less than 12" (305 mm) must be approved by the local codes and/or by the local authority having jurisdiction.

Clearances Requirements

NOTE: A 36-inch minimum clearance is required between the top of the cooking surface and the bottom of an unprotected cabinet. A 30-inch clearance can be used when the bottom of the wood or metal cabinet is protected by not less than 1/4 inch of a flame retardant material covered with not less than No. 28 MSG sheet steel, 0.015 inch (0.4 mm) thick stainless steel, 0.024 inch (0.6 mm) aluminum, or 0.020 inch (0.5 mm) thick copper.



Thermador 

BUILT-IN OVENS

PROFESSIONAL & MASTERPIECE® SERIES

An array of industry-leading features and exclusives make Thermador® Built-In Ovens the only wall oven for true culinary enthusiasts. It starts with our revolutionary Steam & Convection Oven which provides the taste, texture and quality to match your passion for cooking. Thermador wall ovens feature a massive 4.7 cubic foot capacity, the fastest preheat in the luxury segment, an industry exclusive SoftClose® door, and a record-setting two-hour cleaning mode. Our exclusive Triple Combination Oven with Convection Microwave and Warming Drawer creates the ultimate culinary utopia with outstanding performance and simple installation with just one cutout.

Professional Series

Featuring an exquisite analog chronometer, stainless steel knobs, professional styling and unsurpassed performance, Thermador Professional® Series Ovens bring beauty and power together to create the only true professional level built-in ovens on the market.

Masterpiece® Series

The cornerstone of the passionate cook's kitchen, the Masterpiece® Series Single and Double Built-in Ovens provide 14 cooking modes, easy-to-use graphical displays and incomparable Thermador quality and design. Six cooking levels and True Convection make it easy to cook several dishes simultaneously without any flavor transfer.



The New Cooking Revolution RUNS ON STEAM

No true cook's kitchen is truly complete without the power of steam. And no steam oven is complete without the power of convection. You'll find both in the Thermador® Steam & Convection Oven.

Built-In Ovens COMMON FEATURES

All Thermador Professional® and Masterpiece® Built-In Ovens feature these common ingredients to create the ultimate cooking experience for true culinary enthusiasts.



CONVECTION BEYOND CONVENTION

The Steam & Convection Oven features a Thermador True Convection baffle system that directs heat to cook foods faster and more evenly than other convection systems.

BRING ON THE BIRD

Forget about getting up early on holidays. You can cook a 14-pound turkey in just 90 minutes in the oven Combination Mode. Golden on the outside. Moist on the inside.

A GOURMET'S GOURMET TOOL

If you ask a professional chef about steam, you'll quickly understand its power, especially when combined with convection. Food is crisp on the outside and moist on the inside, just like it was being served at a 5-star restaurant.

SAVOR THE RESULTS

The Steam & Convection Oven trumps all the other ovens when it comes to texture, appearance, and, of course, taste. Multiple dishes can be cooked to perfection at the same time with no flavor transfer or temperature adjustment needed.

ENHANCED FLAVORS

Food tastes better and loses fewer vitamins and minerals when cooked with steam. Plus, steam helps eliminate the need to use unhealthy fats and oils.

BETTER-THE-NEXT-DAY REHEATING

When properly reheated, some leftovers taste better than when they were originally served. Steam lets you reheat without losing any moisture, texture or flavor.

40 EASYCOOK® PROGRAMS

From gently steamed cauliflower florets to a succulent leg of lamb, the Steam & Convection Oven's 40 pre-programmed modes automatically set oven temperature and humidity for perfect results.

DESIGN CHOICES

Choose either a Masterpiece® or a Professional product to match your wall oven or Professional range.

★ MASSIVE CAPACITY

With 4.7 cubic feet of cooking space, the 30-inch Thermador Professional® and Masterpiece® Series Ovens are one of the largest in their class*, capable of handling even the largest dinner parties.

*According to AHAM Standards

★ SUPER FAST PREHEAT

Our exclusive Super Fast Preheat feature preheats your oven in 7 minutes, the fastest in its class.

★ FASTEST SELF-CLEAN

In just 2 hours, the interior walls and rack supports become perfectly clean, thanks to the fastest self-cleaning cycle on the market.

★ SOFTCLOSE® DOOR

SoftClose hinges prevent slamming and ensure ultra smooth closing of the oven door.

SPEED CONVECTION

No preheat needed. Reduce cooking times for frozen foods up to 30% with the industry-leading Speed Convection system from Thermador®. Your creations are cooked evenly, perfectly and in less time than ever before.

SOFTLIGHT

Halogen theater lighting dims on and off each time you open and close the oven door to highlight yet another grand cooking performance.

TELESCOPIC RACKS

Up to 3 Full Access® telescopic racks glide smoothly on ball bearings, allowing them to expand completely for safe, easy access to your meal. Plus, their robust construction safely supports the heaviest dishes while integrated easy-grip handles make them easy to use.

TRUE CONVECTION

The thoughtfully engineered and perfectly executed True Convection baffle system allows hot air to flow precisely and evenly around food for perfect results and no flavor transfer.

STAR-K CERTIFIED

Thermador Built-In Ovens are Star-K certified making it possible to use them on the Sabbath or the Holidays.



★ THERMADOR® EXCLUSIVE





BUILT-IN OVENS PROFESSIONAL SERIES

Stainless steel knobs, professional handles and an analog chronometer exude professional quality, outstanding design and timeless beauty.

★ HEAVY-DUTY ROTISSERIE

Thermador Professional® Built-in Ovens offer the best performing rotisserie available. With up to 12-pound capacity, it cooks large roasts and poultry evenly on all sides and cleans up easily with dishwasher-safe components.

★ MAXBROIL®

The Thermador exclusive 5,000 Watt, 12-pass broil element is the most powerful on the market, allowing you to broil even the largest dishes more evenly for perfect results every time.



BUILT-IN OVENS MASTERPIECE® SERIES

With a chiseled look and stainless steel finish that reflect your own impeccable taste, the Masterpiece® oven is more than an appliance. It is an inspiration.

VARIETY OF COOKING MODES

Masterpiece® Series Ovens feature 14 advanced cooking modes as unique as the recipes you plan on creating. These include True Convection, EasyCook® and many more, giving you the freedom to cook any way you choose.

A PERFECT DESIGN COMBINATION

Masterpiece® Built-in-Ovens are available with a professional handle, creating a perfectly blended style. The combination of a digital control panel and bold professional handle elevates the kitchen to new heights in design.



★ THERMADOR® EXCLUSIVE

PSO301M 30-INCH STEAM AND CONVECTION SINGLE BUILT-IN OVEN PROFESSIONAL SERIES



FEATURES & BENEFITS

- ★ - Bold chiseled professional design with restaurant style stainless steel knobs and handle
- ★ - Until now steam has been the technique for professional restaurants and is now available for the culinary enthusiast
- ★ - Steam and Convection Cooking provides unrivaled taste and quality—Food stays moist on the inside and is perfect on the outside
- ★ - The ultimate culinary tool—the Steam and Convection Oven offers passionate cooks three cooking solutions—Steam, True Convection, and Steam and Convection
 - CookControl™ Temperature probe

GENERAL PROPERTIES

Modes

(13) Steam, Steam Convection, True Convection, Reheat, Keep Warm, Defrost, Slow Cook, Proof, Dish Warming, 40 Easy Cook® Programs, Favorites, Steam Clean, CookControl™ Temperature Probe

Cleaning Type	Steam Clean
Illumination Type	Halogen
Interior Lights	2

OVEN PERFORMANCE

Steam Element Wattages	1,960 W
Convection Element Wattages	1,960 W

TECHNICAL DETAILS

Watts (W)	1,960 W
Circuit Breaker (A)	15 A
Volts (V)	240 / 208 V
Frequency (Hz)	60 Hz
Plug Type	Fixed Connection, No Plug
Conduit	48" Flexible 3-Wire
Energy Source	Electric
Installation Type	Non-Plumbed

DIMENSIONS & WEIGHT

Overall Appliance Dimensions (HxWxD) (in)	19 5/8" x 29 3/4" x 22 11/16"
Required Cutout Size (HxWxD) (in)	19 3/16" x 28 1/2" x 23 1/2"
Oven Cavity Size (cu. ft.)	1.4 cu. ft.
Overall Oven Interior Dimensions (HxWxD) (in)	14" x 9 5/8" x 15 3/4"
Usable Oven Interior Dimensions (HxWxD) (in)	12" x 7 3/4" x 15 5/8"
Net Weight (lbs)	78 lbs

ACCESSORIES (INCLUDED)

Wire Rack, Perforated Cooking Pan – Full Size, Baking Tray, Perforated Cooking Pan – Half Size Cooking

WARRANTY

Limited Warranty Parts and Labor	2 Year
----------------------------------	--------

ACCESSORIES (OPTIONAL)

	CS1XLH Cooking Pan—Half size, 1 5/8" deep		CS2XLPH Perforated Cooking Pan— Full size, 1 5/8" deep
	CS1XLPH Perforated Cooking Pan— Half size, 1 5/8" deep		CS2LH Baking Tray—Full size, 1 1/8" deep
	CS2XLH Cooking Pan—Full size, 1 5/8" deep		CSRACKH Wire Rack for Steam and Convection Oven

★ THERMADOR® EXCLUSIVE

MES301HP

24-INCH STEAM AND CONVECTION SINGLE BUILT-IN OVEN

MASTERPIECE® SERIES WITH PROFESSIONAL HANDLE



FEATURES & BENEFITS

- ★ - Until now steam has been the technique for professional restaurants and is now available for the culinary enthusiast
- ★ - Steam and Convection Cooking provides unrivaled taste and quality—Food stays moist on the inside and is perfect on the outside
- ★ - The ultimate culinary tool—the Steam and Convection Oven offers passionate cooks three cooking solutions—Steam, True Convection, and Steam and Convection

GENERAL PROPERTIES

Modes	
(12) Steam, Steam Convection, True Convection, Reheat, Keep Warm, Defrost, Slow Cook, Proof, Dish Warming, 40 Easy Cook® Programs, Favorites, Steam Clean	
Cleaning Type	Steam Clean
Illumination Type	Halogen
Interior Lights	2

OVEN PERFORMANCE

Steam Element Wattages	1,960 W
Convection Element Wattages	1,960 W

TECHNICAL DETAILS

Watts (W)	1,960 W
Circuit Breaker (A)	15 A
Volts (V)	240 / 208 V
Frequency (Hz)	60 Hz
Plug Type	Fixed Connection, No Plug
Conduit	71" Flexible 3-Wire
Energy Source	Electric
Installation Type	Non-Plumbed

DIMENSIONS & WEIGHT

Overall Appliance Dimensions (HxWxD) (in)	17 7/8" x 23 3/8" x 21 5/8"
Required Cutout Size (HxWxD) (in)	17 3/4" x 22" x 24"
Oven Cavity Size (cu. ft.)	1.4 cu. ft.
Overall Oven Interior Dimensions (HxWxD) (in)	14" x 9 5/8" x 15 3/4"
Usable Oven Interior Dimensions (HxWxD) (in)	12" x 7 3/4" x 15 5/8"
Net Weight (lbs)	61 lbs

ACCESSORIES (INCLUDED)

Wire Rack, Perforated Cooking, Pan – Full Size, Baking Tray, Perforated Cooking, Pan – Half Size Cooking

WARRANTY

Limited Warranty Parts and Labor	2 Year
----------------------------------	--------

ACCESSORIES (OPTIONAL)

 MST271KS 27" Trim Kit for Steam and Convection Oven	 CS1XLPH Perforated Cooking Pan—Half size, 1 5/8" deep	 CS2LH Baking Tray—Full size, 1 1/8" deep
 MST301HS 30" Trim Kit for Steam and Convection Oven	 CS2XLH Cooking Pan—Full size, 1 5/8" deep	 CSRACKH Wire Rack for Steam and Convection Oven
 CS1XLH Cooking Pan—Half size, 1 5/8" deep	 CS2XLPH Perforated Cooking Pan—Full size, 1 5/8" deep	

★ THERMADOR® EXCLUSIVE

MES301HS

24-INCH STEAM AND CONVECTION SINGLE BUILT-IN OVEN

MASTERPIECE® SERIES



FEATURES & BENEFITS

- ★ - Until now steam has been the technique for professional restaurants and is now available for the culinary enthusiast
- ★ - Steam and Convection Cooking provides unrivaled taste and quality—Food stays moist on the inside and is perfect on the outside
- ★ - The ultimate culinary tool—the Steam and Convection Oven offers passionate cooks three cooking solutions—Steam, True Convection, and Steam and Convection

GENERAL PROPERTIES

Modes	
(12) Steam, Steam Convection, True Convection, Reheat, Keep Warm, Defrost, Slow Cook, Proof, Dish Warming, 40 Easy Cook® Programs, Favorites, Steam Clean	
Cleaning Type	Steam Clean
Illumination Type	Halogen
Interior Lights	2

OVEN PERFORMANCE

Steam Element Wattages	1,960 W
Convection Element Wattages	1,960 W

TECHNICAL DETAILS

Watts (W)	1,960 W
Circuit Breaker (A)	15 A
Volts (V)	240 / 208 V
Frequency (Hz)	60 Hz
Plug Type	Fixed Connection, No Plug
Conduit	71" Flexible 3-Wire
Energy Source	Electric
Installation Type	Non-Plumbed

DIMENSIONS & WEIGHT

Overall Appliance Dimensions (HxWxD) (in)	17 7/8" x 23 3/8" x 21 5/8"
Required Cutout Size (HxWxD) (in)	17 3/4" x 22" x 24"
Oven Cavity Size (cu. ft.)	1.4 cu. ft.
Overall Oven Interior Dimensions (HxWxD) (in)	14" x 9 5/8" x 15 3/4"
Usable Oven Interior Dimensions (HxWxD) (in)	12" x 7 3/4" x 15 5/8"
Net Weight (lbs)	61 lbs

ACCESSORIES (INCLUDED)

Wire Rack, Perforated Cooking, Pan – Full Size, Baking Tray, Perforated Cooking, Pan – Half Size Cooking

WARRANTY

Limited Warranty Parts and Labor	2 Year
----------------------------------	--------

ACCESSORIES (OPTIONAL)

 MST271KS 27" Trim Kit for Steam and Convection Oven	 CS1XLPH Perforated Cooking Pan—Half size, 1 5/8" deep	 CS2LH Baking Tray—Full size, 1 1/8" deep
 MST301HS 30" Trim Kit for Steam and Convection Oven	 CS2XLH Cooking Pan—Full size, 1 5/8" deep	 CSRACKH Wire Rack for Steam and Convection Oven
 CS1XLH Cooking Pan—Half size, 1 5/8" deep	 CS2XLPH Perforated Cooking Pan—Full size, 1 5/8" deep	

★ THERMADOR® EXCLUSIVE

POD301J
30-INCH SINGLE BUILT-IN OVEN
PROFESSIONAL SERIES



GENERAL PROPERTIES

Modes	(14) Bake, Roast, True Convection, Convection Roast, No Preheat Speed Convection, Warm, Dehydrate, Rotisserie, Maxbroil®, Max Convection Broil, Cook Control™ Probe, Self Clean, Sabbath, Fast Preheat
Cleaning Type	Self Clean
Telescopic Rack(s)	2
Illumination Type	Halogen with SoftLight Function
Interior Lights	4

OVEN PERFORMANCE

Bake Element Wattages	2,000 W
Broil Element Wattages	5,000 W
Convection Element Wattages	2,000 W

TECHNICAL DETAILS

Watts (W)	7,300 W
Circuit Breaker (A)	30 A
Volts (V)	240 / 208 V
Frequency (Hz)	60 Hz
Plug Type	Fixed Connection, No Plug
Conduit	66" Flexible 4-Wire
Energy Source	Electric

DIMENSIONS & WEIGHT

Overall Appliance Dimensions (HxWxD) (in)	29 1/16" x 29 3/4" x 23 7/8"
Required Cutout Size (HxWxD) (in)	28 1/4" x 28 1/2" x 24"
Oven Cavity Size (cu. ft.)	4.7 cu. ft.
Overall Oven Interior Dimensions (HxWxD) (in)	17 7/8" x 25" x 17 7/8"
Usable Oven Interior Dimensions (HxWxD) (in)	14 3/8" x 22 3/4" x 17 1/4"
Net Weight (lbs)	166 lbs

ACCESSORIES (INCLUDED)

2 Telescopic and 1 Standard Oven Rack, Temperature Probe, Broiler Pan, Rotisserie

WARRANTY

Limited Warranty Parts and Labor	2 Year
----------------------------------	--------



FEATURES & BENEFITS

- ★ - SoftClose® door ensures ultra smooth closing of the oven door
- ★ - Fastest preheat in the luxury segment
- ★ - Largest commercial style rotisserie with 12 pound capacity
- ★ - Maxbroil, the largest, most powerful broil element on the market
- 2 Full Access® telescopic racks
- No preheat Speed Convection mode

ACCESSORIES (OPTIONAL)



TLSCPRCK30
30-Inch Oven Telescopic Rack

MED301JP
30-INCH SINGLE BUILT-IN OVEN
MASTERPIECE® SERIES WITH PROFESSIONAL HANDLE



GENERAL PROPERTIES

Modes	(18) Bake, Roast, True Convection, Convection Bake, Convection Roast, No Preheat Speed Convection, Warm, EasyCook®, Broil, Convection Broil, Pizza, Proof, Dehydrate, Cook Control™, Cook Control™ Probe, Self Clean, Sabbath, Favorites, Fast Preheat
Cleaning Type	Self Clean
Telescopic Rack(s)	2
Illumination Type	Halogen with SoftLight Function
Interior Lights	3

OVEN PERFORMANCE

Bake Element Wattages	2,000 W
Broil Element Wattages	3,600 W
Convection Element Wattages	2,000 W

TECHNICAL DETAILS

Watts (W)	7,300 W
Circuit Breaker (A)	30 A
Volts (V)	240 / 208 V
Frequency (Hz)	60 Hz
Plug Type	Fixed Connection, No Plug
Conduit	66" Flexible 4-Wire
Energy Source	Electric

DIMENSIONS & WEIGHT

Overall Appliance Dimensions (HxWxD) (in)	29 1/16" x 29 3/4" x 23 7/8"
Required Cutout Size (HxWxD) (in)	28 1/4" x 28 1/2" x 24"
Oven Cavity Size (cu. ft.)	4.7 cu. ft.
Overall Oven Interior Dimensions (HxWxD) (in)	17 7/8" x 25" x 17 7/8"
Usable Oven Interior Dimensions (HxWxD) (in)	12 3/4" x 22 3/4" x 17 1/4"
Net Weight (lbs)	166 lbs

ACCESSORIES (INCLUDED)

2 Telescopic and 1 Standard Oven Rack, Temperature Probe, Broiler Pan

WARRANTY

Limited Warranty Parts and Labor	2 Year
----------------------------------	--------



FEATURES & BENEFITS

- ★ - SoftClose® door ensures ultra smooth closing of the oven door
- ★ - Fastest preheat in the luxury segment
- ★ - Superfast 2-hour self clean mode-fastest on the market
- 2 Full Access® telescopic racks
- No preheat Speed Convection mode

ACCESSORIES (OPTIONAL)



TLSCPRCK30
30-Inch Oven Telescopic Rack

ME301JP
30-INCH SINGLE BUILT-IN OVEN
 MASTERPIECE® SERIES WITH PROFESSIONAL HANDLE



GENERAL PROPERTIES

Modes
 (18) Bake, Roast, True Convection, Convection Bake, Convection Roast, No Preheat Speed Convection, Warm, EasyCook®, Broil, Convection Broil, Pizza, Proof, Dehydrate, Cook Control™, Cook Control™ Probe, Self Clean, Sabbath, Favorites, Fast Preheat

Cleaning Type	Self Clean
Telescopic Rack(s)	1
Illumination Type	Halogen
Interior Lights	3

OVEN PERFORMANCE

Bake Element Wattages	2,000 W
Broil Element Wattages	3,600 W
Convection Element Wattages	2,000 W

TECHNICAL DETAILS

Watts (W)	7,300 W
Circuit Breaker (A)	30 A
Volts (V)	240 / 208 V
Frequency (Hz)	60 Hz
Plug Type	Fixed Connection, No Plug
Conduit	66" Flexible 4-Wire
Energy Source	Electric

DIMENSIONS & WEIGHT

Overall Appliance Dimensions (HxWxD) (in)	29 1/16" x 29 3/4" x 23 7/8"
Required Cutout Size (HxWxD) (in)	28 1/4" x 28 1/2" x 24"
Oven Cavity Size (cu. ft.)	4.7 cu. ft.
Overall Oven Interior Dimensions (HxWxD) (in)	17 7/8" x 25" x 17 7/8"
Usable Oven Interior Dimensions (HxWxD) (in)	12 3/4" x 22 3/4" x 17 1/4"
Net Weight (lbs)	166 lbs

ACCESSORIES (INCLUDED)

1 Telescopic and 2 Standard Oven Rack, Temperature Probe, Broiler Pan

WARRANTY

Limited Warranty Parts and Labor	2 Year
----------------------------------	--------



FEATURES & BENEFITS

- ★ - SoftClose® door ensures ultra smooth closing of the oven door
- ★ - Fastest preheat in the luxury segment
- ★ - Superfast 2-hour self clean mode-fastest on the market
 - 1 Full Access® telescopic rack
 - No preheat Speed Convection mode

ACCESSORIES (OPTIONAL)



TLSCPRCK30
 30-Inch Oven Telescopic Rack

MED301JS
30-INCH SINGLE BUILT-IN OVEN
 MASTERPIECE® SERIES



GENERAL PROPERTIES

Modes
 (18) Bake, Roast, True Convection, Convection Bake, Convection Roast, No Preheat Speed Convection, Warm, EasyCook®, Broil, Convection Broil, Pizza, Proof, Dehydrate, Cook Control™, Cook Control™ Probe, Self Clean, Sabbath, Favorites, Fast Preheat

Cleaning Type	Self Clean
Telescopic Rack(s)	2
Illumination Type	Halogen with SoftLight Function
Interior Lights	3

OVEN PERFORMANCE

Bake Element Wattages	2,000 W
Broil Element Wattages	3,600 W
Convection Element Wattages	2,000 W

TECHNICAL DETAILS

Watts (W)	7,300 W
Circuit Breaker (A)	30 A
Volts (V)	240 / 208 V
Frequency (Hz)	60 Hz
Plug Type	Fixed Connection, No Plug
Conduit	66" Flexible 4-Wire
Energy Source	Electric

DIMENSIONS & WEIGHT

Overall Appliance Dimensions (HxWxD) (in)	29 1/16" x 29 3/4" x 23 7/8"
Required Cutout Size (HxWxD) (in)	28 1/4" x 28 1/2" x 24"
Oven Cavity Size (cu. ft.)	4.7 cu. ft.
Overall Oven Interior Dimensions (HxWxD) (in)	17 7/8" x 25" x 17 7/8"
Usable Oven Interior Dimensions (HxWxD) (in)	12 3/4" x 22 3/4" x 17 1/4"
Net Weight (lbs)	166 lbs

ACCESSORIES (INCLUDED)

2 Telescopic and 1 Standard Oven Rack, Temperature Probe, Broiler Pan

WARRANTY

Limited Warranty Parts and Labor	2 Year
----------------------------------	--------



FEATURES & BENEFITS

- ★ - SoftClose® door ensures ultra smooth closing of the oven door
- ★ - Fastest preheat in the luxury segment
- ★ - Superfast 2-hour self clean mode-fastest on the market
 - 2 Full Access® telescopic racks
 - No preheat Speed Convection mode

ACCESSORIES (OPTIONAL)



TLSCPRCK30
 30-Inch Oven Telescopic Rack

MED271JS
27-INCH SINGLE BUILT-IN OVEN
MASTERPIECE® SERIES



GENERAL PROPERTIES

Modes
(18) Bake, Roast, True Convection, Convection Bake, Convection Roast, No Preheat Speed Convection, Warm, EasyCook®, Broil, Convection Broil, Pizza, Proof, Dehydrate, Cook Control™, Cook Control™ Probe, Self Clean, Sabbath, Favorites, Fast Preheat

Cleaning Type	Self Clean
Telescopic Rack(s)	2
Illumination Type	Halogen with SoftLight Function
Interior Lights	3

OVEN PERFORMANCE

Bake Element Wattages	2,000 W
Broil Element Wattages	3,600 W
Convection Element Wattages	2,000 W

TECHNICAL DETAILS

Watts (W)	7,300 W
Circuit Breaker (A)	30 A
Volts (V)	240 / 208 V
Frequency (Hz)	60 Hz
Plug Type	Fixed Connection, No Plug
Conduit	66" Flexible 4-Wire
Energy Source	Electric

DIMENSIONS & WEIGHT

Overall Appliance Dimensions (HxWxD) (in)	29 1/16" x 26 3/4" x 23 7/8"
Required Cutout Size (HxWxD) (in)	28 1/4" x 25 1/2" x 24"
Oven Cavity Size (cu. ft.)	4.2 cu. ft.
Overall Oven Interior Dimensions (HxWxD) (in)	17 7/8" x 22" x 17 3/4"
Usable Oven Interior Dimensions (HxWxD) (in)	12 5/8" x 19 3/4" x 17 1/8"
Net Weight (lbs)	153 lbs

ACCESSORIES (INCLUDED)

2 Telescopic and 1 Standard Oven Rack, Temperature Probe, Broiler Pan

WARRANTY

Limited Warranty Parts and Labor	2 Year
----------------------------------	--------

FEATURES & BENEFITS

- ★ - SoftClose® door ensures ultra smooth closing of the oven door
- ★ - Fastest preheat in the luxury segment
- ★ - Superfast 2-hour self clean mode-fastest on the market
 - 2 Full Access® telescopic racks
 - No preheat Speed Convection mode

ACCESSORIES (OPTIONAL)



TLSCPRCK27
27-Inch Oven Telescopic Rack

ME301JS
30-INCH SINGLE BUILT-IN OVEN
MASTERPIECE® SERIES



GENERAL PROPERTIES

Modes
(18) Bake, Roast, True Convection, Convection Bake, Convection Roast, No Preheat Speed Convection, Warm, EasyCook®, Broil, Convection Broil, Pizza, Proof, Dehydrate, Cook Control™, Cook Control™ Probe, Self Clean, Sabbath, Favorites, Fast Preheat

Cleaning Type	Self Clean
Telescopic Rack(s)	1
Illumination Type	Halogen
Interior Lights	3

OVEN PERFORMANCE

Bake Element Wattages	2,000 W
Broil Element Wattages	3,600 W
Convection Element Wattages	2,000 W

TECHNICAL DETAILS

Watts (W)	7,300 W
Circuit Breaker (A)	30 A
Volts (V)	240 / 208 V
Frequency (Hz)	60 Hz
Plug Type	Fixed Connection, No Plug
Conduit	66" Flexible 4-Wire
Energy Source	Electric

DIMENSIONS & WEIGHT

Overall Appliance Dimensions (HxWxD) (in)	29 1/16" x 29 3/4" x 23 7/8"
Required Cutout Size (HxWxD) (in)	28 1/4" x 28 1/2" x 24"
Oven Cavity Size (cu. ft.)	4.7 cu. ft.
Overall Oven Interior Dimensions (HxWxD) (in)	17 7/8" x 25" x 17 7/8"
Usable Oven Interior Dimensions (HxWxD) (in)	12 3/4" x 22 3/4" x 17 1/4"
Net Weight (lbs)	166 lbs

ACCESSORIES (INCLUDED)

1 Telescopic and 2 Standard Oven Rack, Temperature Probe, Broiler Pan

WARRANTY

Limited Warranty Parts and Labor	2 Year
----------------------------------	--------

FEATURES & BENEFITS

- ★ - SoftClose® door ensures ultra smooth closing of the oven door
- ★ - Fastest preheat in the luxury segment
- ★ - Superfast 2-hour self clean mode-fastest on the market
 - 1 Full Access® telescopic rack
 - No preheat Speed Convection mode

ACCESSORIES (OPTIONAL)



TLSCPRCK30
30-Inch Oven Telescopic Rack

PODC302J
30-INCH DOUBLE BUILT-IN OVEN
PROFESSIONAL SERIES



GENERAL PROPERTIES

Modes – Upper Cavity
(14) Bake, Roast, True Convection, Convection Roast, No Preheat Speed Convection, Warm, Dehydrate, Rotisserie, Maxbroil®, Max Convection Broil, Cook Control™ Probe, Self Clean, Sabbath, Fast Preheat

Modes – Lower Cavity
(13) Bake, Roast, Convection Bake, Convection Roast, No Preheat Speed Convection, Warm, Broil, Convection Broil, Proof, Dehydrate, Self Clean, Sabbath, Fast Preheat

Cleaning Type – Upper Cavity	Self Clean
Cleaning Type – Lower Cavity	Self Clean
Telescopic Rack(s)	3
Illumination Type – Upper & Lower Cavity	Halogen with SoftLight Function
Interior Lights – Upper Cavity	4
Interior Lights – Lower Cavity	4

OVEN PERFORMANCE

Bake / Broil Element Wattages – Upper Cavity	2,000 / 5,000 W
Convection Element Wattages – Upper Cavity	2,000 W
Bake / Broil Element Wattages – Lower Cavity	2,000 / 3,600 W
Convection Element Wattages – Lower Cavity	2,000 W

TECHNICAL DETAILS

Watts (W)	9,000 W
Circuit Breaker (A)	40 A
Volts (V)	240 / 208 V
Frequency (Hz)	60 Hz
Plug Type	Fixed Connection, No Plug
Conduit	66" Flexible 4-Wire
Energy Source	Electric

DIMENSIONS & WEIGHT

Overall Appliance Dimensions (HxWxD) (in)	51 3/4" x 29 3/4" x 23 7/8"
Required Cutout Size (HxWxD) (in)	51 1/8" x 28 1/2" x 24"
Oven Cavity Size – Upper / Lower Cavity (cu. ft.)	4.7 cu. ft. / 4.7 cu. ft.
Overall Oven Interior Dimensions (HxWxD) (in)	17 7/8" x 25" x 17 7/8"
Usable Oven Interior Dimensions (HxWxD) (in)	14 3/8" x 22 3/4" x 17 1/4"
Net Weight (lbs)	294 lbs

ACCESSORIES (INCLUDED)

Upper Cavity: 2 Telescopic and 1 Standard Oven Rack, Temperature Probe, Broiler Pan, Rotisserie Lower Cavity: 1 Telescopic and 2 Standard Oven Rack

WARRANTY

Limited Warranty Parts and Labor	2 Year
----------------------------------	--------



FEATURES & BENEFITS

- ★ - SoftClose® door ensures ultra smooth closing of the oven door
- ★ - Fastest preheat in the luxury segment
- ★ - Largest commercial style rotisserie with 12 pound capacity
- ★ - Maxbroil, the largest, most powerful broil element on the market
- 3 Full Access® telescopic racks
- No preheat Speed Convection mode

ACCESSORIES (OPTIONAL)



TLSCPRCK30
30-Inch Oven Telescopic Rack

MED302JP
30-INCH DOUBLE BUILT-IN OVEN
MASTERPIECE® SERIES WITH PROFESSIONAL HANDLE



GENERAL PROPERTIES

Modes – Upper Cavity
(18) Bake, Roast, True Convection, Convection Bake, Convection Roast, No Preheat Speed Convection, Warm, EasyCook®, Broil, Convection Broil, Pizza, Proof, Dehydrate, Cook Control™ Probe, Self Clean, Sabbath, Favorites, Fast Preheat

Modes – Lower Cavity
(17) Bake, Roast, True Convection, Convection Bake, Convection Roast, No Preheat Speed Convection, Warm, EasyCook®, Broil, Convection Broil, Pizza, Proof, Dehydrate, Self Clean, Sabbath, Favorites, Fast Preheat

Cleaning Type – Upper Cavity	Self Clean
Cleaning Type – Lower Cavity	Self Clean
Telescopic Rack(s)	3
Illumination Type – Upper & Lower Cavity	Halogen with SoftLight Function
Interior Lights – Upper Cavity	3
Interior Lights – Lower Cavity	3

OVEN PERFORMANCE

Bake / Broil Element Wattages – Upper Cavity	2,000 / 3,600 W
Convection Element Wattages – Upper Cavity	2,000 W
Bake / Broil Element Wattages – Lower Cavity	2,000 / 3,600 W
Convection Element Wattages – Lower Cavity	2,000 W

TECHNICAL DETAILS

Watts (W)	8,000 W
Circuit Breaker (A)	40 A
Volts (V)	240 / 208 V
Frequency (Hz)	60 Hz
Plug Type	Fixed Connection, No Plug
Conduit	66" Flexible 4-Wire
Energy Source	Electric

DIMENSIONS & WEIGHT

Overall Appliance Dimensions (HxWxD) (in)	51 3/4" x 29 3/4" x 23 7/8"
Required Cutout Size (HxWxD) (in)	51 1/8" x 28 1/2" x 24"
Oven Cavity Size – Upper / Lower Cavity (cu. ft.)	4.7 cu. ft. / 4.7 cu. ft.
Overall Oven Interior Dimensions (HxWxD) (in)	17 7/8" x 25" x 17 7/8"
Usable Oven Interior Dimensions (HxWxD) (in)	12 3/4" x 22 3/4" x 17 1/4"
Net Weight (lbs)	294 lbs

ACCESSORIES (INCLUDED)

Upper Cavity: 2 Telescopic and 1 Standard Oven Rack, Temperature Probe, Broiler Pan Lower Cavity: 1 Telescopic and 2 Standard Oven Rack

WARRANTY

Limited Warranty Parts and Labor	2 Year
----------------------------------	--------

FEATURES & BENEFITS

- ★ - SoftClose® door ensures ultra smooth closing of the oven door
- ★ - Fastest preheat in the luxury segment
- ★ - Superfast 2-hour self clean mode-fastest on the market
- 3 Full Access® telescopic racks
- No preheat Speed Convection mode

ACCESSORIES (OPTIONAL)



TLSCPRCK30
30-Inch Oven Telescopic Rack



ME302JP
30-INCH DOUBLE BUILT-IN OVEN
MASTERPIECE® SERIES WITH PROFESSIONAL HANDLE



GENERAL PROPERTIES

Modes – Upper Cavity
(18) Bake, Roast, True Convection, Convection Bake, Convection Roast, No Preheat Speed Convection, Warm, EasyCook®, Broil, Convection Broil, Pizza, Proof, Dehydrate, Cook Control™ Probe, Self Clean, Sabbath, Favorites, Fast Preheat

Modes – Lower Cavity
(8) Bake, Roast, Warm, Broil, Proof, Self Clean, Sabbath, Favorites

Cleaning Type – Upper Cavity	Self Clean
Cleaning Type – Lower Cavity	Self Clean
Telescopic Rack(s)	1
Illumination Type – Upper & Lower Cavity	Halogen
Interior Lights – Upper Cavity	3
Interior Lights – Lower Cavity	3

OVEN PERFORMANCE

Bake / Broil Element Wattages – Upper Cavity	2,000 / 3,600 W
Convection Element Wattages – Upper Cavity	2,000 W
Bake / Broil Element Wattages – Lower Cavity	2,000 / 3,600 W
Convection Element Wattages – Lower Cavity	N/A

TECHNICAL DETAILS

Watts (W)	7,600 W
Circuit Breaker (A)	40 A
Volts (V)	240 / 208 V
Frequency (Hz)	60 Hz
Plug Type	Fixed Connection, No Plug
Conduit	66" Flexible 4-Wire
Energy Source	Electric



DIMENSIONS & WEIGHT

Overall Appliance Dimensions (HxWxD) (in)	51 3/4" x 29 3/4" x 23 7/8"
Required Cutout Size (HxWxD) (in)	51 1/8" x 28 1/2" x 24"
Oven Cavity Size – Upper / Lower Cavity (cu. ft.)	4.7 cu. ft. / 4.7 cu. ft.
Overall Oven Interior Dimensions (HxWxD) (in)	17 7/8" x 25" x 17 7/8"
Usable Oven Interior Dimensions (HxWxD) (in)	12 3/4" x 22 3/4" x 17 1/4"
Net Weight (lbs)	294 lbs

ACCESSORIES (INCLUDED)

Upper Cavity: 1 Telescopic and 2 Standard Oven Rack, Temperature Probe, Broiler Pan Lower Cavity: 3 Standard Oven Racks

WARRANTY

Limited Warranty Parts and Labor	2 Year
----------------------------------	--------

FEATURES & BENEFITS

- ★ - SoftClose® door ensures ultra smooth closing of the oven door
- ★ - Fastest preheat in the luxury segment
- ★ - Superfast 2-hour self clean mode-fastest on the market
 - 1 Full Access® telescopic rack
 - No preheat Speed Convection mode

ACCESSORIES (OPTIONAL)



TLSCPCK30
30-Inch Oven Telescopic Rack

MED302JS
30-INCH DOUBLE BUILT-IN OVEN
MASTERPIECE® SERIES

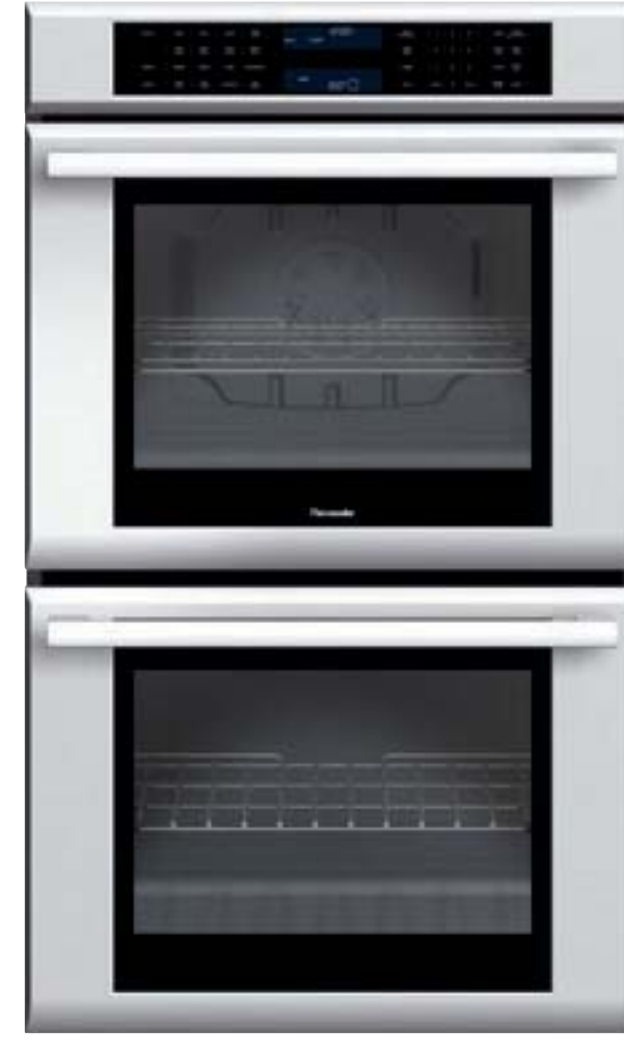

GENERAL PROPERTIES

Modes – Upper Cavity
(18) Bake, Roast, True Convection, Convection Bake, Convection Roast, No Preheat Speed Convection, Warm, EasyCook®, Broil, Convection Broil, Pizza, Proof, Dehydrate, Cook Control™ Probe, Self Clean, Sabbath, Favorites, Fast Preheat

Modes – Lower Cavity
(17) Bake, Roast, True Convection, Convection Bake, Convection Roast, No Preheat Speed Convection, Warm, EasyCook®, Broil, Convection Broil, Pizza, Proof, Dehydrate, Self Clean, Sabbath, Favorites, Fast Preheat

Cleaning Type – Upper Cavity	Self Clean
Cleaning Type – Lower Cavity	Self Clean
Telescopic Rack(s)	3
Illumination Type – Upper & Lower Cavity	Halogen with SoftLight Function
Interior Lights – Upper Cavity	3
Interior Lights – Lower Cavity	3

OVEN PERFORMANCE

Bake / Broil Element Wattages – Upper Cavity	2,000 / 3,600 W
Convection Element Wattages – Upper Cavity	2,000 W
Bake / Broil Element Wattages – Lower Cavity	2,000 / 3,600 W
Convection Element Wattages – Lower Cavity	2,000 W

TECHNICAL DETAILS

Watts (W)	8,000 W
Circuit Breaker (A)	40 A
Volts (V)	240 / 208 V
Frequency (Hz)	60 Hz
Plug Type	Fixed Connection, No Plug
Conduit	66" Flexible 4-Wire
Energy Source	Electric



DIMENSIONS & WEIGHT

Overall Appliance Dimensions (HxWxD) (in)	51 3/4" x 29 3/4" x 23 7/8"
Required Cutout Size (HxWxD) (in)	51 1/8" x 28 1/2" x 24"
Oven Cavity Size – Upper / Lower Cavity (cu. ft.)	4.7 cu. ft. / 4.7 cu. ft.
Overall Oven Interior Dimensions (HxWxD) (in)	17 7/8" x 25" x 17 7/8"
Usable Oven Interior Dimensions (HxWxD) (in)	12 3/4" x 22 3/4" x 17 1/4"
Net Weight (lbs)	294 lbs

ACCESSORIES (INCLUDED)

Upper Cavity: 2 Telescopic and 1 Standard Oven Rack, Temperature Probe, Broiler Pan Lower Cavity: 1 Telescopic and 2 Standard Oven Rack

WARRANTY

Limited Warranty Parts and Labor	2 Year
----------------------------------	--------

FEATURES & BENEFITS

- ★ - SoftClose® door ensures ultra smooth closing of the oven door
- ★ - Fastest preheat in the luxury segment
- ★ - Superfast 2-hour self clean mode-fastest on the market
 - 3 Full Access® telescopic racks
 - No preheat Speed Convection mode

ACCESSORIES (OPTIONAL)



TLSCPCK30
30-Inch Oven Telescopic Rack

ME302JS
30-INCH DOUBLE BUILT-IN OVEN
MASTERPIECE® SERIES



GENERAL PROPERTIES

Modes – Upper Cavity
(18) Bake, Roast, True Convection, Convection Bake, Convection Roast, No Preheat Speed Convection, Warm, EasyCook®, Broil, Convection Broil, Pizza, Proof, Dehydrate, Cook Control™ Probe, Self Clean, Sabbath, Favorites, Fast Preheat

Modes – Lower Cavity
(8) Bake, Roast, Warm, Broil, Proof, Self Clean, Sabbath, Favorites

Cleaning Type – Upper Cavity	Self Clean
Cleaning Type – Lower Cavity	Self Clean
Telescopic Rack(s)	1
Illumination Type – Upper & Lower Cavity	Halogen
Interior Lights – Upper Cavity	3
Interior Lights – Lower Cavity	3

OVEN PERFORMANCE

Bake / Broil Element Wattages – Upper Cavity	2,000 / 3,600 W
Convection Element Wattages – Upper Cavity	2,000 W
Bake / Broil Element Wattages – Lower Cavity	2,000 / 3,600 W
Convection Element Wattages – Lower Cavity	N/A

TECHNICAL DETAILS

Watts (W)	7,600 W
Circuit Breaker (A)	40 A
Volts (V)	240 / 208 V
Frequency (Hz)	60 Hz
Plug Type	Fixed Connection, No Plug
Conduit	66" Flexible 4-Wire
Energy Source	Electric



DIMENSIONS & WEIGHT

Overall Appliance Dimensions (HxWxD) (in)	51 3/4" x 29 3/4" x 23 7/8"
Required Cutout Size (HxWxD) (in)	51 1/8" x 28 1/2" x 24"
Oven Cavity Size – Upper / Lower Cavity (cu. ft.)	4.7 cu. ft. / 4.7 cu. ft.
Overall Oven Interior Dimensions (HxWxD) (in)	17 7/8" x 25" x 17 7/8"
Usable Oven Interior Dimensions (HxWxD) (in)	12 3/4" x 22 3/4" x 17 1/4"
Net Weight (lbs)	294 lbs

ACCESSORIES (INCLUDED)

Upper Cavity: 1 Telescopic and 2 Standard Oven Rack, Temperature Probe, Broiler Pan Lower Cavity: 3 Standard Oven Racks

WARRANTY

Limited Warranty Parts and Labor	2 Year
----------------------------------	--------

FEATURES & BENEFITS

- ★ - SoftClose® door ensures ultra smooth closing of the oven door
- ★ - Fastest preheat in the luxury segment
- ★ - Superfast 2-hour self clean mode-fastest on the market
 - 1 Full Access® telescopic rack
 - No preheat Speed Convection mode

ACCESSORIES (OPTIONAL)



TLSCPCK30
30-Inch Oven Telescopic Rack

MED272JS
27-INCH DOUBLE BUILT-IN OVEN
MASTERPIECE® SERIES



GENERAL PROPERTIES

Modes – Upper Cavity
(18) Bake, Roast, True Convection, Convection Bake, Convection Roast, No Preheat Speed Convection, Warm, EasyCook®, Broil, Convection Broil, Pizza, Proof, Dehydrate, Cook Control™ Probe, Self Clean, Sabbath, Favorites, Fast Preheat

Modes – Lower Cavity
(17) Bake, Roast, True Convection, Convection Bake, Convection Roast, No Preheat Speed Convection, Warm, EasyCook®, Broil, Convection Broil, Pizza, Proof, Dehydrate, Self Clean, Sabbath, Favorites, Fast Preheat

Cleaning Type – Upper Cavity	Self Clean
Cleaning Type – Lower Cavity	Self Clean
Telescopic Rack(s)	3
Illumination Type – Upper & Lower Cavity	Halogen with SoftLight Function
Interior Lights – Upper Cavity	3
Interior Lights – Lower Cavity	3

OVEN PERFORMANCE

Bake / Broil Element Wattages – Upper Cavity	2,000 / 3,600 W
Convection Element Wattages – Upper Cavity	2,000 W
Bake / Broil Element Wattages – Lower Cavity	2,000 / 3,600 W
Convection Element Wattages – Lower Cavity	2,000 W

TECHNICAL DETAILS

Watts (W)	8,000 W
Circuit Breaker (A)	40 A
Volts (V)	240 / 208 V
Frequency (Hz)	60 Hz
Plug Type	Fixed Connection, No Plug
Conduit	66" Flexible 4-Wire
Energy Source	Electric



DIMENSIONS & WEIGHT

Overall Appliance Dimensions (HxWxD) (in)	51 3/4" x 26 3/4" x 23 7/8"
Required Cutout Size (HxWxD) (in)	51 1/8" x 25 1/2" x 24"
Oven Cavity Size – Upper / Lower Cavity (cu. ft.)	4.2 cu. ft. / 4.2 cu. ft.
Overall Oven Interior Dimensions (HxWxD) (in)	17 7/8" x 22" x 17 6/8"
Usable Oven Interior Dimensions (HxWxD) (in)	12 5/8" x 19 3/4" x 17 1/8"
Net Weight (lbs)	281 lbs

ACCESSORIES (INCLUDED)

Upper Cavity: 2 Telescopic and 1 Standard Oven Rack, Temperature Probe, Broiler Pan Lower Cavity: 1 Telescopic and 2 Standard Oven Rack

WARRANTY

Limited Warranty Parts and Labor	2 Year
----------------------------------	--------

FEATURES & BENEFITS

- ★ - SoftClose® door ensures ultra smooth closing of the oven door
- ★ - Fastest preheat in the luxury segment
- ★ - Superfast 2-hour self clean mode-fastest on the market
 - 3 Full Access® telescopic racks
 - No preheat Speed Convection mode

ACCESSORIES (OPTIONAL)



TLSCPCK27
27-Inch Oven Telescopic Rack

PODM301J
30-INCH DOUBLE COMBINATION BUILT-IN OVEN
PROFESSIONAL SERIES



GENERAL PROPERTIES

Modes – Upper Cavity	See MCES for Microwave Features
Modes – Lower Cavity	(14) Bake, Roast, True Convection, Convection Roast, No Preheat Speed Convection, Warm, Dehydrate, Rotisserie, Maxbroil®, Max Convection Broil, Cook Control™ Probe, Self Clean, Sabbath, Fast Preheat
Warming Drawer	N/A
Cleaning Type – Lower Cavity	Self Clean
Telescopic Rack(s)	2
Illumination Type – Upper & Lower Cavity	Halogen with SoftLight Function
Interior Lights – Upper & Lower Cavity	1 / 4

OVEN PERFORMANCE

Microwave Power	1,000 W
Bake / Broil Element Wattages – Lower Cavity	2,000 / 5,000 W
Convection Element Wattages – Lower Cavity	2,000 W
Warming Drawer Wattage	N/A

TECHNICAL DETAILS

Watts (W)	10,200 W
Circuit Breaker (A)	50 A
Volts (V); Frequency (Hz)	240 / 208 V; 60 Hz
Plug Type	Fixed Connection, No Plug
Conduit	66" Flexible 4-Wire
Energy Source	Electric

DIMENSIONS & WEIGHT

Overall Appliance Dimensions (HxWxD) (in)	50" x 29 3/4" x 23 7/8"
Required Cutout Size (HxWxD) (in)	49 1/2" x 28 1/2" x 24"
Microwave Cavity Size (cu. ft.)	1.5 cu. ft.
Oven Cavity Size – Upper / Lower Cavity (cu. ft.)	4.7 cu. ft.
Warming Drawer Cavity Size (cu. ft.)	N/A
Overall Oven Interior Dimensions (HxWxD) (in)	17 7/8" x 25" x 17 7/8"
Usable Oven Interior Dimensions (HxWxD) (in)	14 3/8" x 22 3/4" x 17 1/4"
Net Weight (lbs)	250 lbs

ACCESSORIES (INCLUDED)

Upper Cavity: 1 Oven Rack, 1 Ceramic Glass Tray, 1 Roller Ring Lower Cavity: 2 Telescopic and 1 Standard Oven Rack, Temperature Probe, Broiler Pan, Rotisserie

WARRANTY

Limited Warranty Parts and Labor	2 Year
----------------------------------	--------

FEATURES & BENEFITS

- ★ - SoftClose® door ensures ultra smooth closing of the oven door
- ★ - Largest commercial style rotisserie with 12 pound capacity
- ★ - Maxbroil, the largest, most powerful broil element on the market
 - 2 Full Access® telescopic racks
 - No preheat Speed Convection mode

ACCESSORIES (OPTIONAL)



TLSCPRCK30
30-Inch Oven Telescopic Rack

* Valid for wall oven

MEDMC301JP
30-INCH DOUBLE COMBINATION BUILT-IN OVEN
MASTERPIECE® SERIES WITH PROFESSIONAL HANDLE



GENERAL PROPERTIES

Modes – Upper Cavity	See MCES for Microwave Features
Modes – Lower Cavity	(18) Bake, Roast, True Convection, Convection Bake, Convection Roast, No Preheat Speed Convection, Warm, EasyCook®, Broil, Convection Broil, Pizza, Proof, Dehydrate, Cook Control™ Probe, Self Clean, Sabbath, Favorites, Fast Preheat
Warming Drawer	N/A
Cleaning Type – Lower Cavity	Self Clean
Telescopic Rack(s)	2
Illumination Type – Upper & Lower Cavity	Halogen with SoftLight Function
Interior Lights – Upper & Lower Cavity	1 / 3

OVEN PERFORMANCE

Microwave Power	1,000 W
Bake / Broil Element Wattages – Lower Cavity	2,000 / 3,600 W
Convection Element Wattages – Lower Cavity	2,000 W
Warming Drawer Wattage	N/A

TECHNICAL DETAILS

Watts (W)	10,200 W
Circuit Breaker (A)	50 A
Volts (V); Frequency (Hz)	240 / 208 V; 60 Hz
Plug Type	Fixed Connection, No Plug
Conduit	66" Flexible 4-Wire
Energy Source	Electric

DIMENSIONS & WEIGHT

Overall Appliance Dimensions (HxWxD) (in)	50" x 29 3/4" x 23 7/8"
Required Cutout Size (HxWxD) (in)	49 1/2" x 28 1/2" x 24"
Microwave Cavity Size (cu. ft.)	1.5 cu. ft.
Oven Cavity Size – Upper / Lower Cavity (cu. ft.)	4.7 cu. ft.
Warming Drawer Cavity Size (cu. ft.)	N/A
Overall Oven Interior Dimensions (HxWxD) (in)	17 7/8" x 25" x 17 7/8"
Usable Oven Interior Dimensions (HxWxD) (in)	12 3/4" x 22 3/4" x 17 1/4"
Net Weight (lbs)	250 lbs

ACCESSORIES (INCLUDED)

Upper Cavity: 1 Oven Rack, 1 Ceramic Glass Tray, 1 Roller Ring Lower Cavity: 2 Telescopic and 1 Standard Oven Rack, Temperature Probe, Broiler Pan

WARRANTY

Limited Warranty Parts and Labor	2 Year
----------------------------------	--------

FEATURES & BENEFITS

- ★ - SoftClose® door ensures ultra smooth closing of the oven door
- ★ - Fastest preheat in the luxury segment (around 7 minutes)
- ★ - Superfast 2-hour self clean mode-fastest on the market
 - 2 Full Access® telescopic racks
 - No preheat Speed Convection mode

ACCESSORIES (OPTIONAL)



TLSCPRCK30
30-Inch Oven Telescopic Rack

* Valid for wall oven

MEDMC301JS

30-INCH DOUBLE COMBINATION BUILT-IN OVEN

MASTERPIECE® SERIES



GENERAL PROPERTIES	
Modes – Upper Cavity	See MCES for Microwave Features
Modes – Lower Cavity	(18) Bake, Roast, True Convection, Convection Bake, Convection Roast, No Preheat Speed Convection, Warm, EasyCook®, Broil, Convection Broil, Pizza, Proof, Dehydrate, Cook Control™ Probe, Self Clean, Sabbath, Favorites, Fast Preheat
Warming Drawer	N/A
Cleaning Type – Lower Cavity	Self Clean
Telescopic Rack(s)	2
Illumination Type – Upper & Lower Cavity	Halogen with SoftLight Function
Interior Lights – Upper & Lower Cavity	1 / 3
OVEN PERFORMANCE	
Microwave Power	1,000 W
Bake / Broil Element Wattages – Lower Cavity	2,000 / 3,600 W
Convection Element Wattages – Lower Cavity	2,000 W
Warming Drawer Wattage	N/A
TECHNICAL DETAILS	
Watts (W)	10,200 W
Circuit Breaker (A)	50 A
Volts (V); Frequency (Hz)	240 / 208 V; 60 Hz
Plug Type	Fixed Connection, No Plug
Conduit	66" Flexible 4-Wire
Energy Source	Electric
DIMENSIONS & WEIGHT	
Overall Appliance Dimensions (HxWxD) (in)	50" x 29 3/4" x 23 7/8"
Required Cutout Size (HxWxD) (in)	49 1/2" x 28 1/2" x 24"
Microwave Cavity Size (cu. ft.)	1.5 cu. ft.
Oven Cavity Size – Upper / Lower Cavity (cu. ft.)	4.7 cu. ft.
Warming Drawer Cavity Size (cu. ft.)	N/A
Overall Oven Interior Dimensions (HxWxD) (in)	17 7/8" x 25" x 17 7/8"
Usable Oven Interior Dimensions (HxWxD) (in)	12 3/4" x 22 3/4" x 17 1/4"
Net Weight (lbs)	250 lbs
ACCESSORIES (INCLUDED)	
Upper Cavity: 1 Oven Rack, 1 Ceramic Glass Tray, 1 Roller Ring Lower Cavity: 2 Telescopic and 1 Standard Oven Rack, Temperature Probe, Broiler Pan	
WARRANTY	
Limited Warranty Parts and Labor	2 Year

FEATURES & BENEFITS

- ★ - SoftClose® door ensures ultra smooth closing of the oven door
- ★ - Fastest preheat in the luxury segment (around 7 minutes)
- ★ - Superfast 2-hour self clean mode-fastest on the market
 - 2 Full Access® telescopic racks
 - No preheat Speed Convection mode

ACCESSORIES (OPTIONAL)



TLSCPRCK30
30-Inch Oven Telescopic Rack

* Valid for wall oven

PODMW301J

30-INCH TRIPLE COMBINATION BUILT-IN OVEN

PROFESSIONAL SERIES



GENERAL PROPERTIES	
Modes – Upper Cavity	See MCES for Microwave Features
Modes – Lower Cavity	(14) Bake, Roast, True Convection, Convection Roast, No Preheat Speed Convection, Warm, Dehydrate, Rotisserie, Maxbroil®, Max Convection Broil, Cook Control™ Probe, Self Clean, Sabbath, Fast Preheat
Warming Drawer	See WD30JP for all Warming Drawer Details
Cleaning Type – Lower Cavity	Self Clean
Telescopic Rack(s)	2
Illumination Type – Upper & Lower Cavity	Halogen with SoftLight Function
Interior Lights – Upper & Lower Cavity	1 / 4
OVEN PERFORMANCE	
Microwave Power	1,000 W
Bake / Broil Element Wattages – Lower Cavity	2,000 / 5,000 W
Convection Element Wattages – Lower Cavity	2,000 W
Warming Drawer Wattage	450 W
TECHNICAL DETAILS	
Watts (W)	10,500 W
Circuit Breaker (A)	50 A
Volts (V); Frequency (Hz)	240 / 208 V; 60 Hz
Plug Type	Fixed Connection, No Plug
Conduit	66" Flexible 4-Wire
Energy Source	Electric
DIMENSIONS & WEIGHT	
Overall Appliance Dimensions (HxWxD) (in)	61 3/8" x 29 3/4" x 23 7/8"
Required Cutout Size (HxWxD) (in)	60 3/4" x 28 1/2" x 24"
Microwave Cavity Size (cu. ft.)	1.5 cu. ft.
Oven Cavity Size – Upper / Lower Cavity (cu. ft.)	4.7 cu. ft.
Warming Drawer Cavity Size (cu. ft.)	2.6 cu. ft.
Overall Oven Interior Dimensions (HxWxD) (in)	17 7/8" x 25" x 17 7/8"
Usable Oven Interior Dimensions (HxWxD) (in)	12 3/4" x 22 3/4" x 17 1/4"
Net Weight (lbs)	324 lbs
ACCESSORIES (INCLUDED)	
Upper Cavity: 1 Oven Rack, 1 Ceramic Glass Tray, 1 Roller Ring Lower Cavity: 2 Telescopic and 1 Standard Oven Rack, Temperature Probe, Broiler Pan, Rotisserie	
WARRANTY	
Limited Warranty Parts and Labor	2 Year

FEATURES & BENEFITS

- ★ - SoftClose® door ensures ultra smooth closing of the oven door
- ★ - Largest commercial style rotisserie with 12 pound capacity
- ★ - Maxbroil, the largest, most powerful broil element on the market
 - 2 Full Access® telescopic racks
 - No preheat Speed Convection mode

ACCESSORIES (OPTIONAL)



TLSCPRCK30
30-Inch Oven Telescopic Rack

* Valid for wall oven and warming drawer

MEDMCW31JP

30-INCH TRIPLE COMBINATION BUILT-IN OVEN

MASTERPIECE® SERIES WITH PROFESSIONAL HANDLE



FEATURES & BENEFITS

- ★ - SoftClose® door ensures ultra smooth closing of the oven door
- ★ - Fastest preheat in the luxury segment (around 7 minutes)
- ★ - Superfast 2-hour self clean mode-fastest on the market
 - 2 Full Access® telescopic racks
 - No preheat Speed Convection mode

ACCESSORIES (OPTIONAL)



TLSCPRCK30
30-Inch Oven Telescopic Rack

GENERAL PROPERTIES

Modes – Upper Cavity	See MCES for Microwave Features
Modes – Lower Cavity	(18) Bake, Roast, True Convection, Convection Bake, Convection Roast, No Preheat Speed Convection, Warm, EasyCook®, Broil, Convection Broil, Pizza, Proof, Dehydrate, Cook Control™ Probe, Self Clean, Sabbath, Favorites, Fast Preheat
Warming Drawer	See WD30JS for all Warming Drawer Details
Cleaning Type – Lower Cavity	Self Clean
Telescopic Rack(s)	2
Illumination Type – Upper & Lower Cavity	Halogen with SoftLight Function
Interior Lights – Upper & Lower Cavity	1 / 3

OVEN PERFORMANCE

Microwave Power	1,000 W
Bake / Broil Element Wattages – Lower Cavity	2,000 / 3,600 W
Convection Element Wattages – Lower Cavity	2,000 W
Warming Drawer Wattage	450 W

TECHNICAL DETAILS

Watts (W)	10,500 W
Circuit Breaker (A)	50 A
Volts (V); Frequency (Hz)	240 / 208 V; 60 Hz
Plug Type	Fixed Connection, No Plug
Conduit	66" Flexible 4-Wire
Energy Source	Electric

DIMENSIONS & WEIGHT

Overall Appliance Dimensions (HxWxD) (in)	61 3/8" x 29 3/4" x 23 7/8"
Required Cutout Size (HxWxD) (in)	60 3/4" x 28 1/2" x 24"
Microwave Cavity Size (cu. ft.)	1.5 cu. ft.
Oven Cavity Size – Upper / Lower Cavity (cu. ft.)	4.7 cu. ft.
Warming Drawer Cavity Size (cu. ft.)	2.6 cu. ft.
Overall Oven Interior Dimensions (HxWxD) (in)	17 7/8" x 25" x 17 7/8"
Usable Oven Interior Dimensions (HxWxD) (in)	12 3/4" x 22 3/4" x 17 1/4"
Net Weight (lbs)	324 lbs

ACCESSORIES (INCLUDED)

Upper Cavity: 1 Oven Rack, 1 Ceramic Glass Tray, 1 Roller Ring Lower Cavity: 2 Telescopic and 1 Standard Oven Rack, Temperature Probe, Broiler Pan

WARRANTY

Limited Warranty Parts and Labor	2 Year
----------------------------------	--------

* Valid for wall oven and warming drawer

MEDMCW31JS

30-INCH TRIPLE COMBINATION BUILT-IN OVEN

MASTERPIECE® SERIES



FEATURES & BENEFITS

- ★ - SoftClose® door ensures ultra smooth closing of the oven door
- ★ - Fastest preheat in the luxury segment (around 7 minutes)
- ★ - Superfast 2-hour self clean mode-fastest on the market
 - 2 Full Access® telescopic racks
 - No preheat Speed Convection mode

ACCESSORIES (OPTIONAL)



TLSCPRCK30
30-Inch Oven Telescopic Rack

GENERAL PROPERTIES

Modes – Upper Cavity	See MCES for Microwave Features
Modes – Lower Cavity	(18) Bake, Roast, True Convection, Convection Bake, Convection Roast, No Preheat Speed Convection, Warm, EasyCook®, Broil, Convection Broil, Pizza, Proof, Dehydrate, Cook Control™ Probe, Self Clean, Sabbath, Favorites, Fast Preheat
Warming Drawer	See WD30JS for all Warming Drawer Details
Cleaning Type – Lower Cavity	Self Clean
Telescopic Rack(s)	2
Illumination Type – Upper & Lower Cavity	Halogen with SoftLight Function
Interior Lights – Upper & Lower Cavity	1 / 3

OVEN PERFORMANCE

Microwave Power	1,000 W
Bake / Broil Element Wattages – Lower Cavity	2,000 / 3,600 W
Convection Element Wattages – Lower Cavity	2,000 W
Warming Drawer Wattage	450 W

TECHNICAL DETAILS

Watts (W)	10,500 W
Circuit Breaker (A)	50 A
Volts (V); Frequency (Hz)	240 / 208 V; 60 Hz
Plug Type	Fixed Connection, No Plug
Conduit	66" Flexible 4-Wire
Energy Source	Electric

DIMENSIONS & WEIGHT

Overall Appliance Dimensions (HxWxD) (in)	61 3/8" x 29 3/4" x 23 7/8"
Required Cutout Size (HxWxD) (in)	60 3/4" x 28 1/2" x 24"
Microwave Cavity Size (cu. ft.)	1.5 cu. ft.
Oven Cavity Size – Upper / Lower Cavity (cu. ft.)	4.7 cu. ft.
Warming Drawer Cavity Size (cu. ft.)	2.6 cu. ft.
Overall Oven Interior Dimensions (HxWxD) (in)	17 7/8" x 25" x 17 7/8"
Usable Oven Interior Dimensions (HxWxD) (in)	12 3/4" x 22 3/4" x 17 1/4"
Net Weight (lbs)	324 lbs

ACCESSORIES (INCLUDED)

Upper Cavity: 1 Oven Rack, 1 Ceramic Glass Tray, 1 Roller Ring Lower Cavity: 2 Telescopic and 1 Standard Oven Rack, Temperature Probe, Broiler Pan

WARRANTY

Limited Warranty Parts and Labor	2 Year
----------------------------------	--------

* Valid for wall oven and warming drawer

MEDMCW71JS

27-INCH TRIPLE COMBINATION BUILT-IN OVEN

MASTERPIECE® SERIES



BUILT-IN OVENS

PLANNING INFORMATION



FEATURES & BENEFITS

- ★ - SoftClose® door ensures ultra smooth closing of the oven door
- ★ - Fastest preheat in the luxury segment (around 7 minutes)
- ★ - Superfast 2-hour self clean mode-fastest on the market
 - 2 Full Access® telescopic racks
 - No preheat Speed Convection mode

ACCESSORIES (OPTIONAL)



TLSCPRCK27
27-Inch Oven Telescopic Rack

GENERAL PROPERTIES

Modes – Upper Cavity	See MCES for Microwave Features
Modes – Lower Cavity	(18) Bake, Roast, True Convection, Convection Bake, Convection Roast, No Preheat Speed Convection, Warm, EasyCook®, Broil, Convection Broil, Pizza, Proof, Dehydrate, Cook Control™ Probe, Self Clean, Sabbath, Favorites, Fast Preheat
Warming Drawer	See WD30JS for all Warming Drawer Details
Cleaning Type – Lower Cavity	Self Clean
Telescopic Rack(s)	2
Illumination Type – Upper & Lower Cavity	Halogen with SoftLight Function
Interior Lights – Upper & Lower Cavity	1 / 3

OVEN PERFORMANCE

Microwave Power	1,000 W
Bake / Broil Element Wattages – Lower Cavity	2000 / 3,600 W
Convection Element Wattages – Lower Cavity	2,000 W
Warming Drawer Wattage	450 W

TECHNICAL DETAILS

Watts (W)	10,500 W
Circuit Breaker (A)	50 A
Volts (V); Frequency (Hz)	240 / 208 V; 60 Hz
Plug Type	Fixed Connection, No Plug
Conduit	66" Flexible 4-Wire
Energy Source	Electric

DIMENSIONS & WEIGHT

Overall Appliance Dimensions (HxWxD) (in)	61 3/8" x 26 3/4" x 23 7/8"
Required Cutout Size (HxWxD) (in)	60 3/4" x 25 1/2" x 24"
Microwave Cavity Size (cu. ft.)	1.5 cu. ft.
Oven Cavity Size – Upper / Lower Cavity (cu. ft.)	4.2 cu. ft.
Warming Drawer Cavity Size (cu. ft.)	2.3 cu. ft.
Overall Oven Interior Dimensions (HxWxD) (in)	22" x 17 7/8" x 17 6/8"
Usable Oven Interior Dimensions (HxWxD) (in)	19 3/4" x 12 5/8" x 17 1/8"
Net Weight (lbs)	274 lbs

ACCESSORIES (INCLUDED)

Upper Cavity: 1 Oven Rack, 1 Ceramic Glass Tray, 1 Roller Ring Lower Cavity: 2 Telescopic and 1 Standard Oven Rack, Temperature Probe, Broiler Pan

WARRANTY

Limited Warranty Parts and Labor	2 Year
----------------------------------	--------

MODEL OPTIONS

There are two Thermador Built-in Oven series to choose from—Professional and Masterpiece®. Each series features a distinctive style. Be sure to reference the correct model information in this design guide.

INSTALLATION CONSIDERATIONS

The information in this design guide provides key features, product dimensions, cutouts and installation specifications. Before installing a Thermador Oven, be sure to verify the cabinet dimensions and electrical connections. Also, always consult with the installation manual packed with the product for complete details before installing.

For ease of installation, some oven doors may be removed to reduce the weight of the oven by 30 lbs. per door, before installing into the cabinet. Refer to the installation manual for details.

IMPORTANT

When a Thermador Oven is installed at the end of a cabinet run, adjacent to a perpendicular wall or cabinet door, it is good practice to allow at least 1/4" space between the side of the oven and the wall or door.

For oven support, install 2 x 4's extending front to back flush with the bottom and the side of the opening. The supporting base must be well secured to the floor / cabinet, flat / level and capable of supporting at least the weights listed in the chart below.

MINIMUM CABINET BASE SUPPORT WEIGHTS

All Steam and Convection Single Ovens	92 lbs. (42 kg)
27-inch Single Oven	193 lbs. (87 kg)
27-inch Double Oven	361 lbs. (164 kg)
27-inch Triple Combination Oven	369 lbs. (167 kg)
30-inch Single Ovens	212 lbs. (96 kg)
30-inch Double Ovens	390 lbs. (177 kg)
30-inch Double Combination Ovens	310 lbs. (141 kg)
30-inch Triple Combination Ovens	429 lbs. (195 kg)

ELECTRICAL LOCATION

Refer to the appropriate installation diagram for details on conduit box location.

ELECTRICAL SPECIFICATIONS

Be sure your appliance is properly installed and grounded by a qualified technician. Installation, electrical connections and grounding must comply with all applicable local codes.

All built-in ovens below are dual rated, designed to be connected to either 240V / 208V AC, 60 Hz, 4-wire, single-phase power supply. Install a suitable conduit box (not furnished). An appropriately-sized, UL-listed conduit connector must be used to correctly attach the conduit to the junction box.

MODEL	REQUIRED CIRCUIT BREAKER
	240V / 208V, 60 Hz
Steam and Convection Ovens	15 A
Single Ovens	30 A
Double Ovens	40 A
Double Combination Ovens	50 A
Triple Combination Ovens	50 A

IMPORTANT

Local Codes may vary; installation, electrical connections and grounding must comply with all applicable local codes.

If local codes permit grounding through the electrical supply neutral, connect both the white neutral wire and the bare ground wire from the oven to the white neutral electrical supply wire.

A 4-wire connection is preferred, but where local codes permit, a 3-wire connection is also acceptable.

* Valid for wall oven and warming drawer

30-INCH STEAM & CONVECTION BUILT-IN OVEN PROFESSIONAL SERIES INSTALLATION

30-INCH STEAM AND CONVECTION OVEN

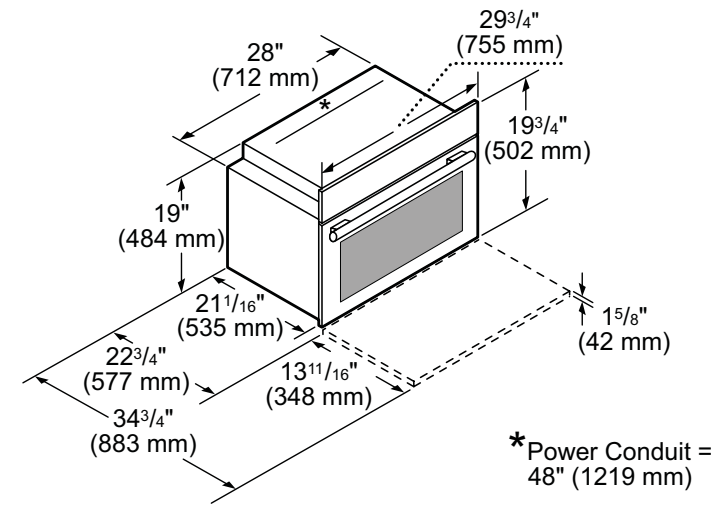

WALL-MOUNTED INSTALLATION

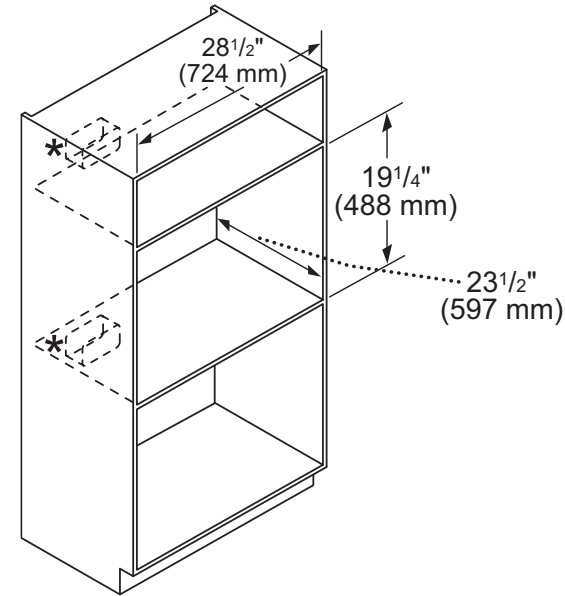

*For single ovens installed into a wall cabinet, the junction box may be located above or beneath the unit within reach of the power cord.

UNDER-COUNTER INSTALLATION

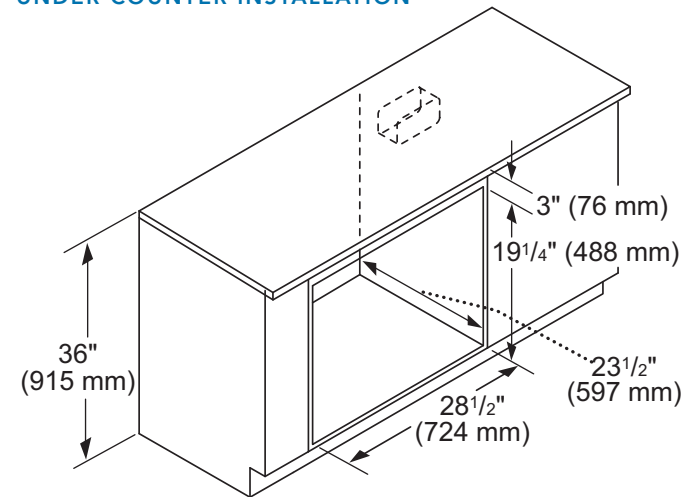

Door Handle Depth*

Professional Handle

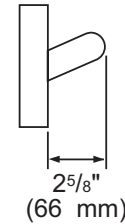

*Protrusion of handle from outer part of door. Does not include thickness of door

30-INCH STEAM & CONVECTION BUILT-IN OVEN PROFESSIONAL SERIES INSTALLATION

30-INCH STEAM AND CONVECTION OVEN OVER SINGLE OVEN

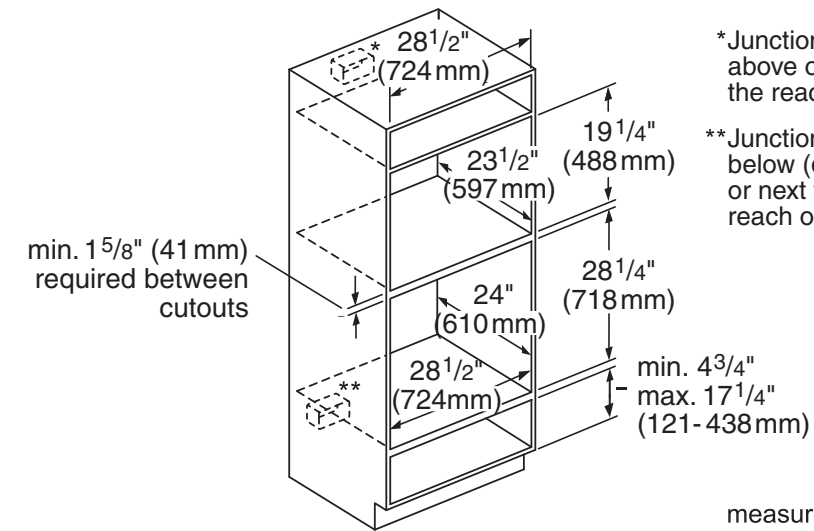

COMBINING PRODUCT IN A WALL-MOUNTED INSTALLATION

Thermador Professional Steam and Convection Ovens may be installed in combination with other Thermador products.

Upper Product	Professional Steam Oven	Professional Steam Oven	Microwave
Lower Product	Wall Oven	Microwave	Professional Steam Oven
Minimum distance between upper and lower product cutout*	1 5/8"	1 1/4"	1 3/4"
Comments		Microwave w/Trim Kit	Microwave w/Trim Kit

*IMPORTANT: cabinet base must be able to support oven weight. Refer to oven manual for minimum weight requirements.
NOTE: recommended air gap between products is 7/8" (included in min. distance)

24-INCH, 27-INCH & 30-INCH STEAM & CONVECTION BUILT-IN OVENS – MASTERPIECE® SERIES INSTALLATION

24-INCH STEAM AND CONVECTION OVEN

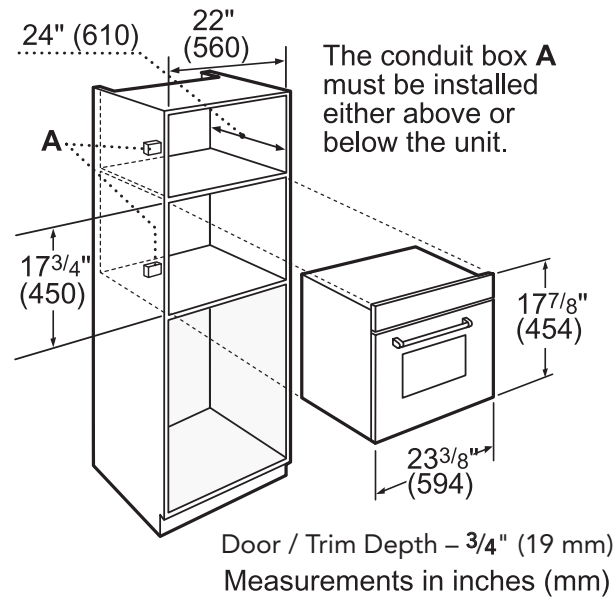

30-INCH (24-INCH STEAM AND CONVECTION OVEN WITH TRIM KIT)

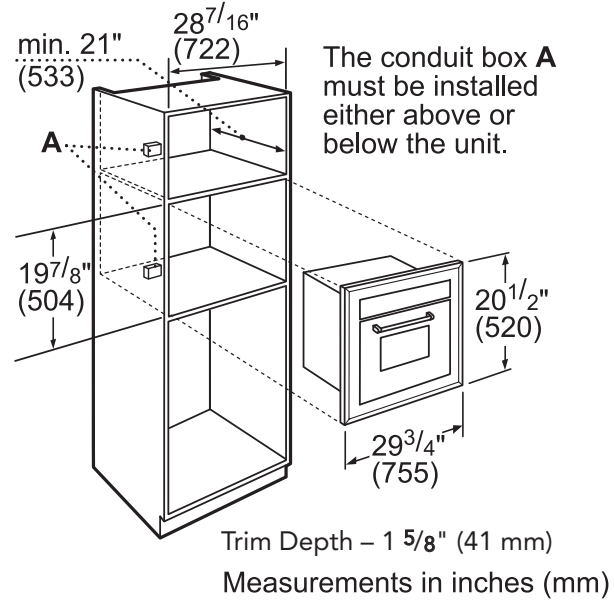

NOTE: 27" Trim Kit cutout width is 25 7/16" and product width is 26 3/4"

MES301HS

Door Handle Depth*

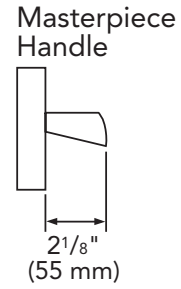

*Protrusion of handle from outer part of door. Does not include thickness of door

MES301HP

Door Handle Depth*

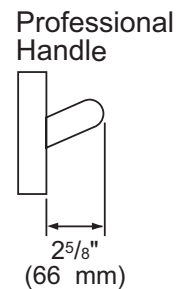

TRIM KIT SPECIFICATIONS		
	27-Inch w/Trim Kit	30-Inch w/Trim Kit
Product Width	26 3/4"	29 3/4"
Product Height	20 1/2"	20 1/2"
Product Depth	21 5/8"	21 5/8"
Door Clearance	15"	15"
Min. Cabinet Width	27"	30"
Min. Cabinet Depth	21"	21"
Cutout Width	25 7/16"	28 7/16"
Cutout Height	19 7/8"	19 7/8"
Trim Overlaps (top - bottom - sides)	3/8" - 3/8" - 5/8"	3/8" - 3/8" - 5/8"

24-INCH, 27-INCH & 30-INCH STEAM & CONVECTION SINGLE BUILT-IN OVENS INSTALLATION

24-INCH STEAM AND CONVECTION OVEN WITH 27-INCH TRIM KIT OVER SINGLE OVEN

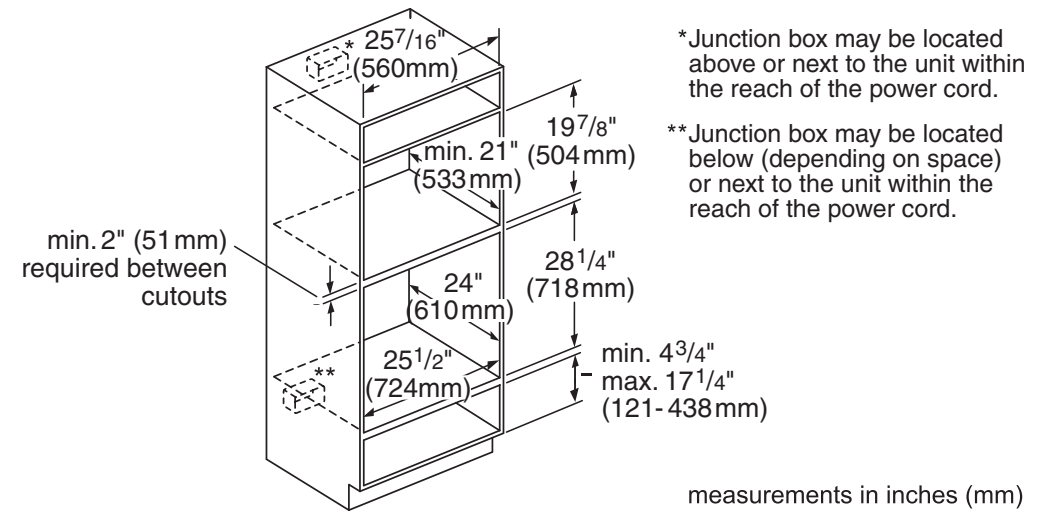

24-INCH STEAM AND CONVECTION OVEN WITH 30-INCH TRIM KIT OVER SINGLE OVEN

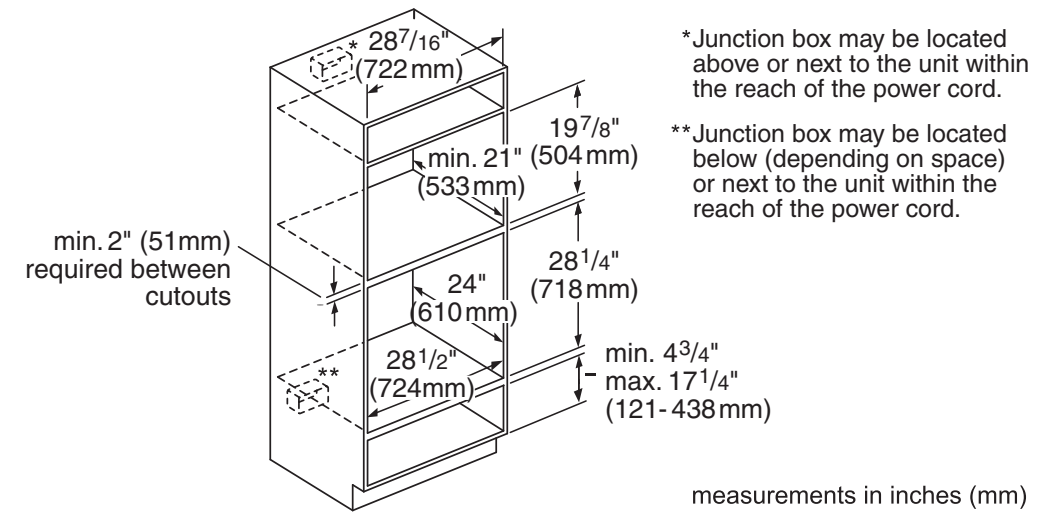

COMBINING PRODUCT IN A WALL-MOUNTED INSTALLATION

Thermador Masterpiece Steam and Convection Ovens may be installed in combination with other Thermador products.

Upper Product	Masterpiece Steam Oven	Masterpiece Steam Oven	Microwave	Coffee Machine
Lower Product	Wall Oven	Microwave	Masterpiece Steam Oven	Masterpiece Steam Oven
Minimum distance between upper and lower product cutout*	2"	1 1/2"	1 1/2"	1 1/8"
Comments	Steam Oven w/Trim Kit		All Products w/Trim Kit	24" Installation (No Trim Kit)

***IMPORTANT:** cabinet base must be able to support oven weight. Refer to oven manual for minimum weight requirements.
NOTE: recommended air gap between products is 7/8" (included in min. distance)

30-INCH SINGLE BUILT-IN OVENS INSTALLATION

30-INCH SINGLE OVEN

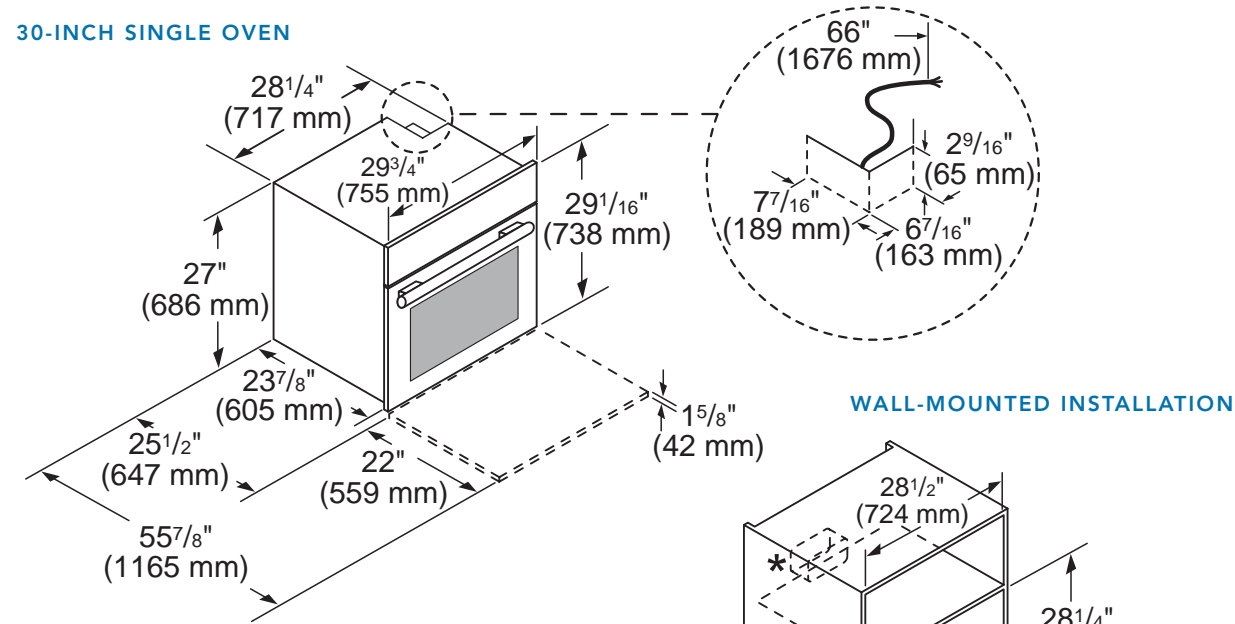

WALL-MOUNTED INSTALLATION

UNDER-COUNTER INSTALLATION

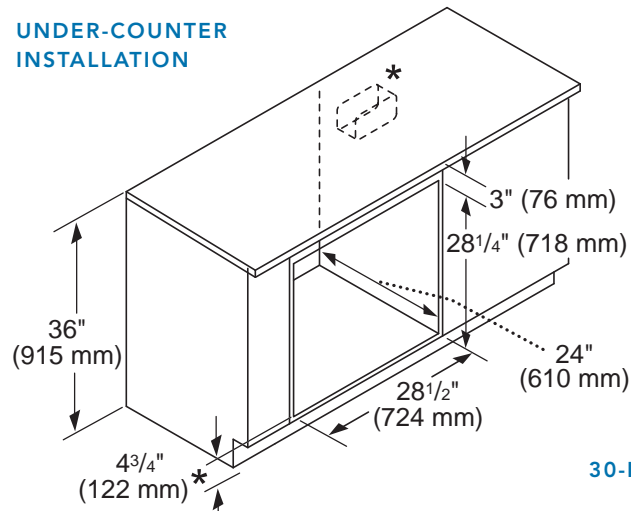

*Includes 3/4" (19 mm) base plate. For single ovens installed under a cabinet, the junction box should be located to the right of the unit with reach of the power cord.

Door Handle Depth*

Professional Handle

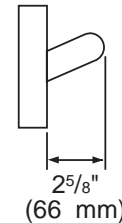

*Protrusion of handle from outer part of door. Does not include thickness of door

Door Handle Depth*

Masterpiece Handle

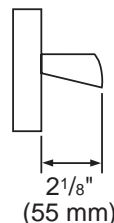

30-INCH SINGLE OVEN OVER WARMING DRAWER

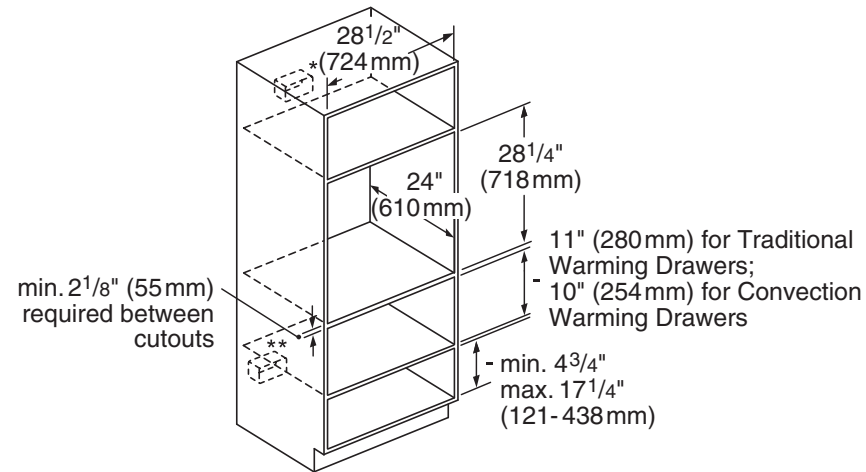

*Wall oven junction box may be located above or right or left of the unit within reach of the power conduit.

**Electrical hook up may be located below (depending on space) or next to the drawer within the reach of the power cord.

27-INCH SINGLE BUILT-IN OVEN INSTALLATION

27-INCH SINGLE OVEN

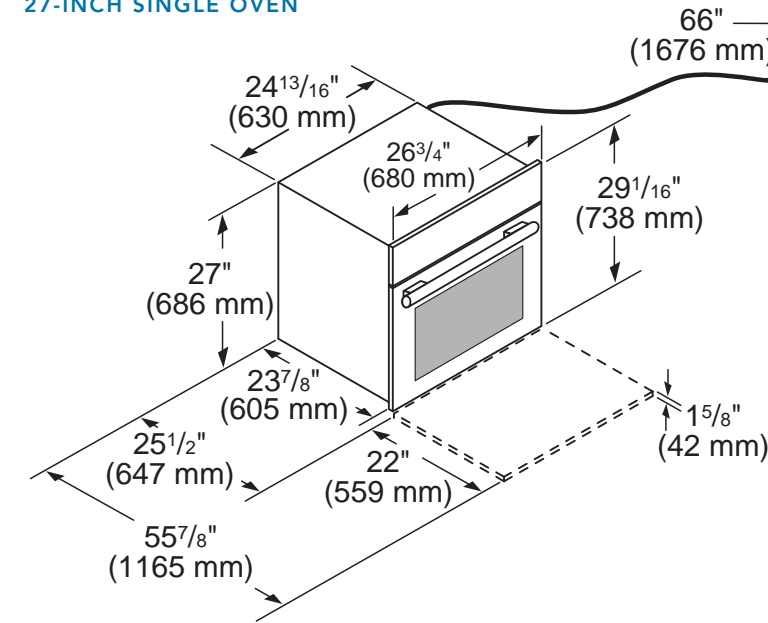

UNDER-COUNTER INSTALLATION

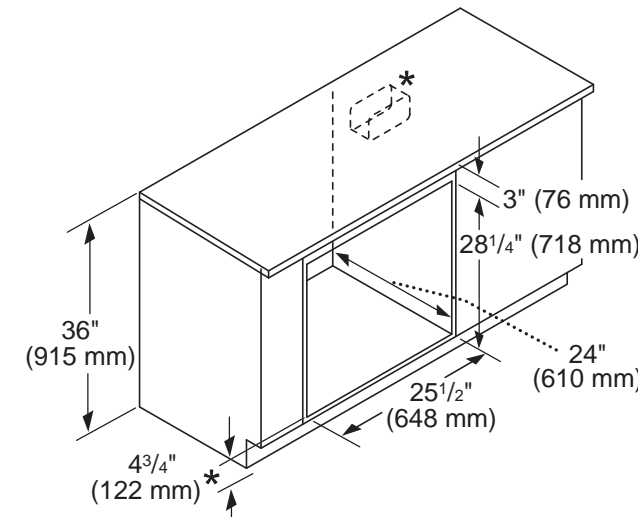

*Includes 3/4" (19 mm) base plate. For single ovens installed under a cabinet, the junction box should be located to the right of the unit with reach of the power cord.

Door Handle Depth*

Masterpiece Handle

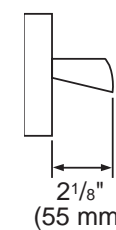

*Protrusion of handle from outer part of door. Does not include thickness of door

WALL-MOUNTED INSTALLATION

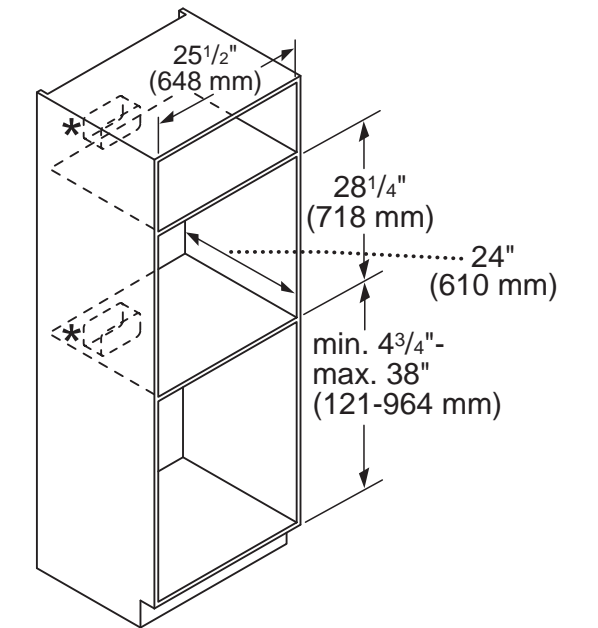

*For single ovens installed into a wall cabinet, the junction box may be located above or beneath the unit within reach of the power cord.

27-INCH SINGLE OVEN OVER WARMING DRAWER

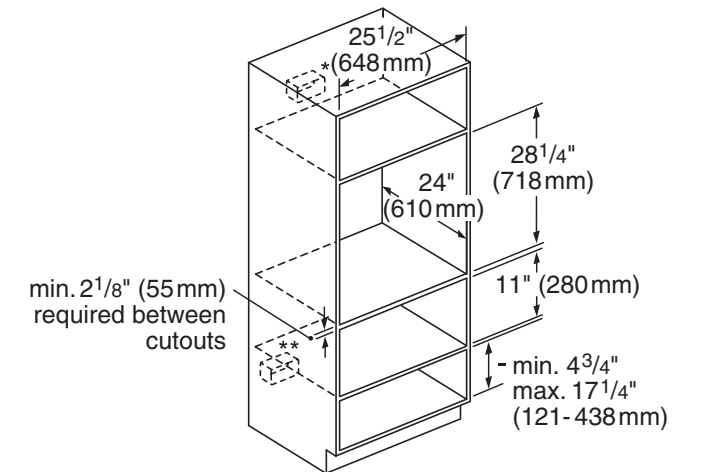

*Wall oven junction box may be located above or right or left of the unit within reach of the power conduit.

**Electrical hook up may be located below (depending on space) or next to the drawer within the reach of the power cord.

30-INCH DOUBLE BUILT-IN OVENS INSTALLATION

30-INCH DOUBLE OVEN

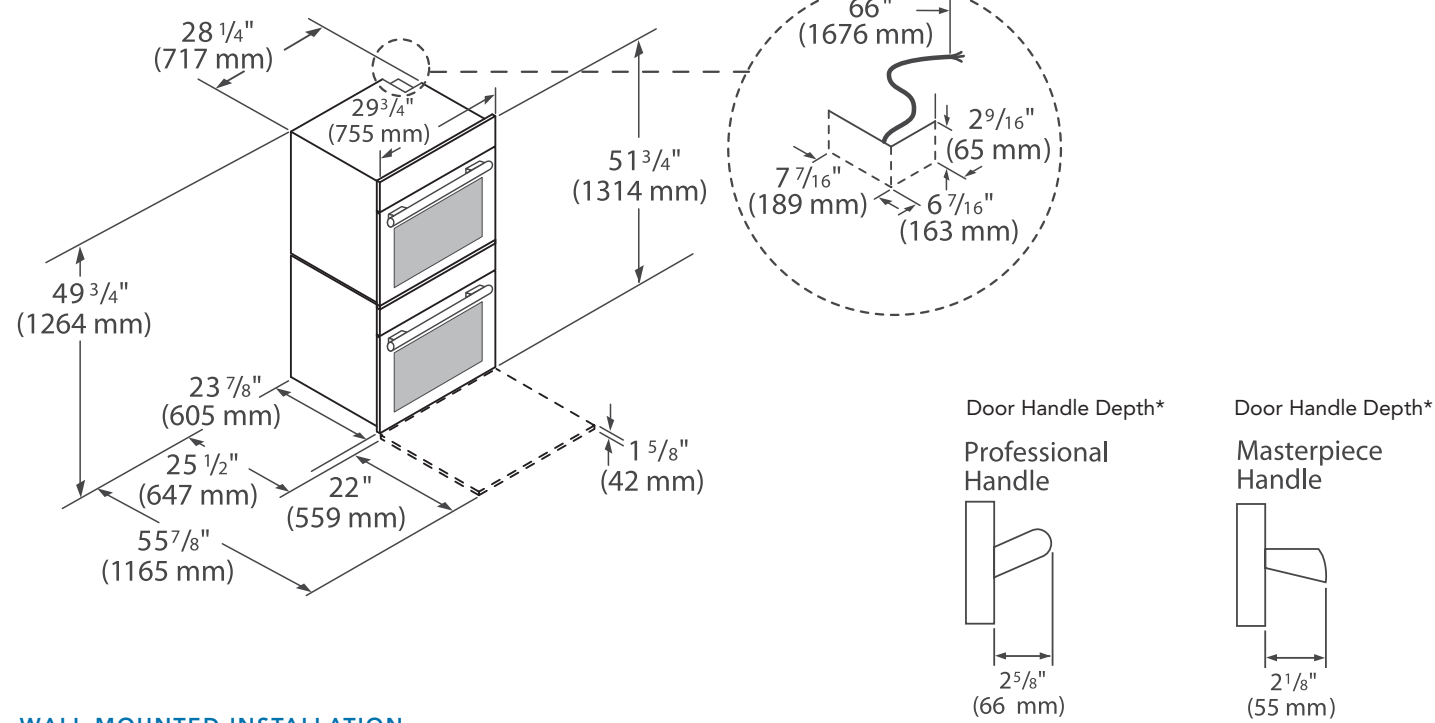

WALL-MOUNTED INSTALLATION

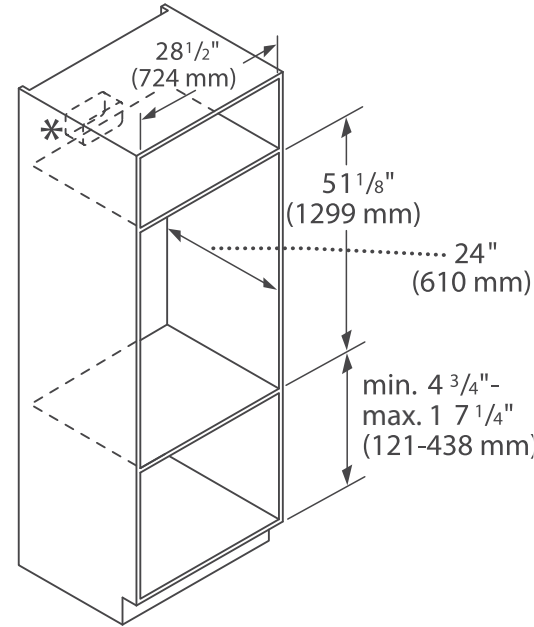

*Junction box may be installed above, below or to the right of the unit within range of the power cable.

30-INCH DOUBLE OVEN OVER WARMING DRAWER

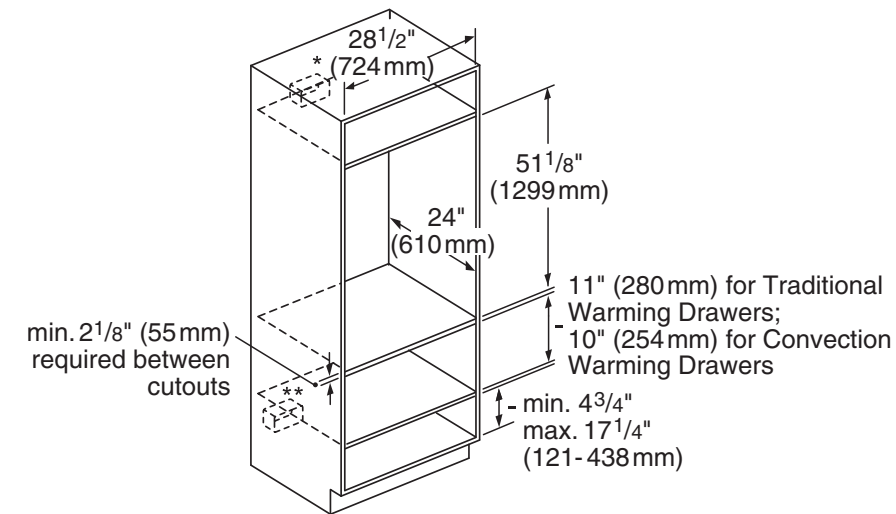

* Wall oven junction box may be located above or right or left of the unit within reach of the power conduit.

** Electrical hook up may be located below (depending on space) or next to the drawer within the reach of the power cord.

27-INCH DOUBLE BUILT-IN OVENS INSTALLATION

27-INCH DOUBLE OVEN

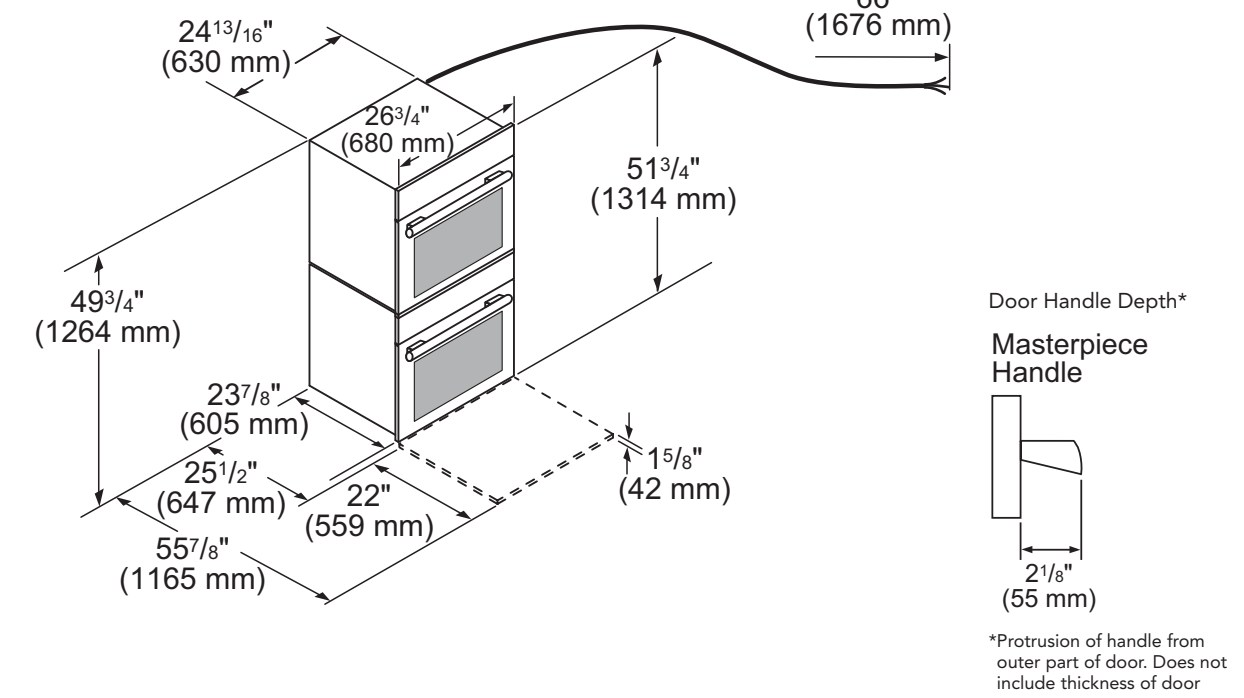

WALL-MOUNTED INSTALLATION

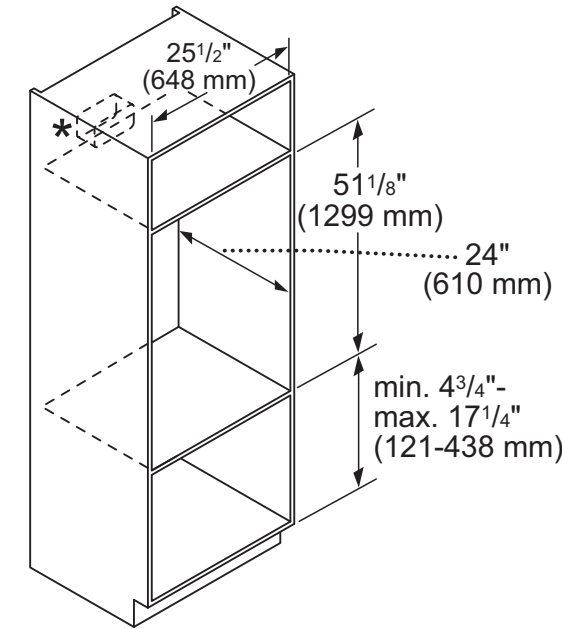

* Junction box may be installed above, below, or to the right of the unit within range of the power cable.

27-INCH DOUBLE OVEN OVER WARMING DRAWER

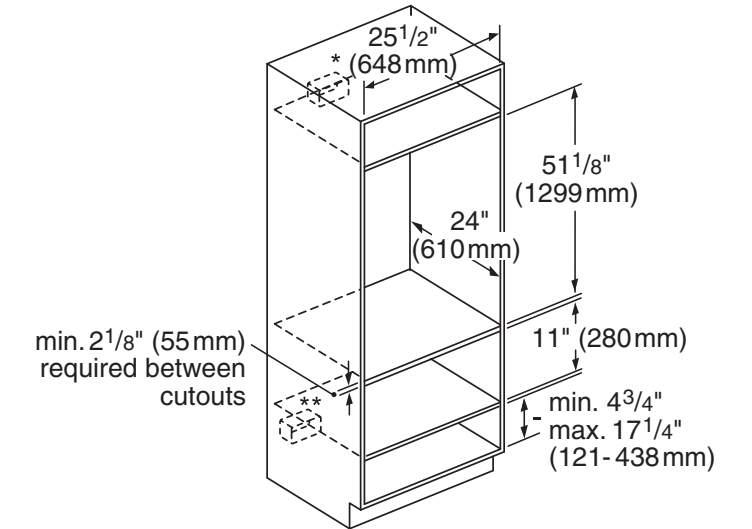

* Wall oven junction box may be located above or right or left of the unit within reach of the power conduit.

** Electrical hook up may be located below (depending on space) or next to the drawer within the reach of the power cord.

30-INCH DOUBLE AND TRIPLE COMBINATION BUILT-IN OVENS INSTALLATION

30-INCH DOUBLE COMBINATION OVEN WITH MICROWAVE

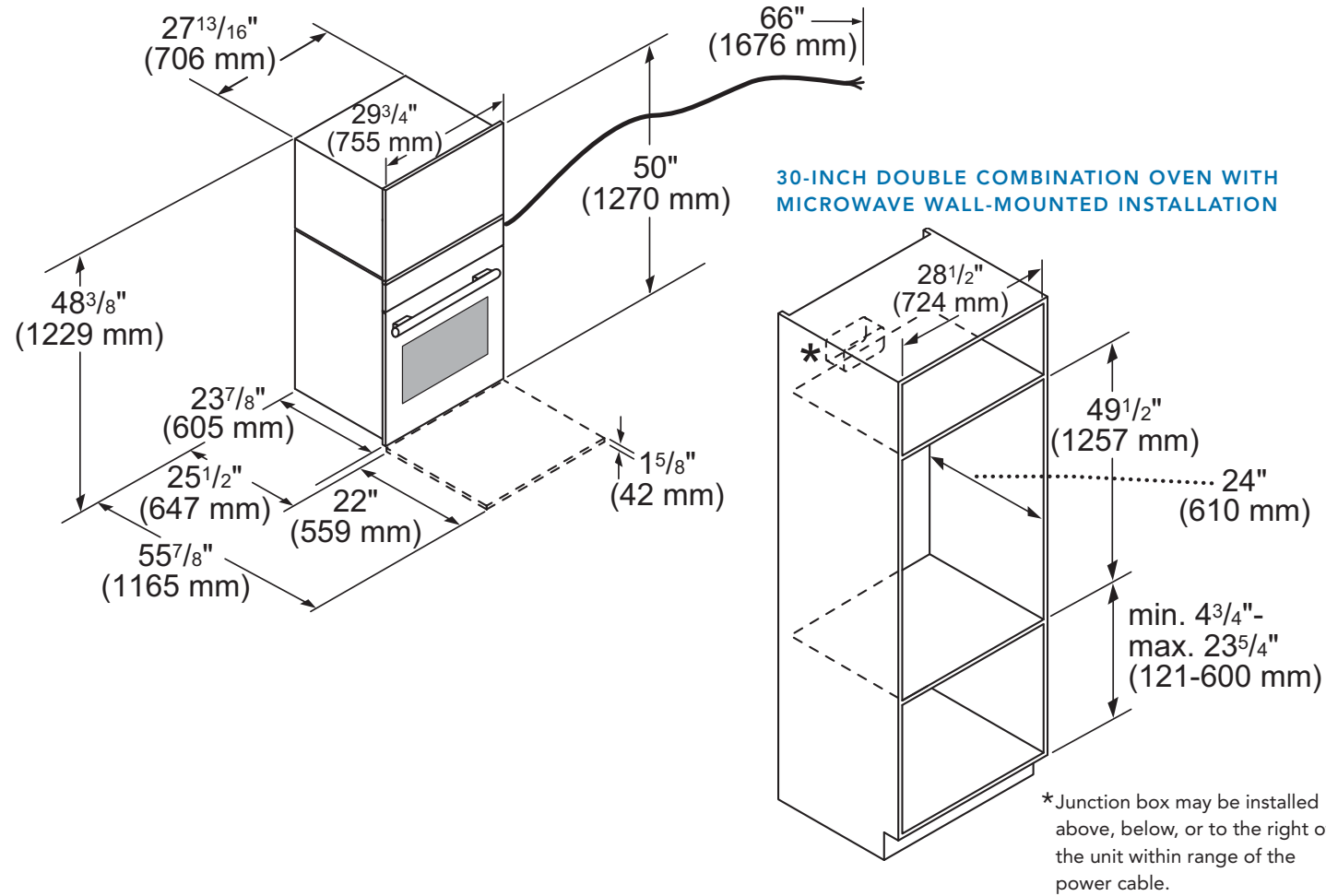

30-INCH TRIPLE COMBINATION OVEN WITH MICROWAVE AND WARMING DRAWER

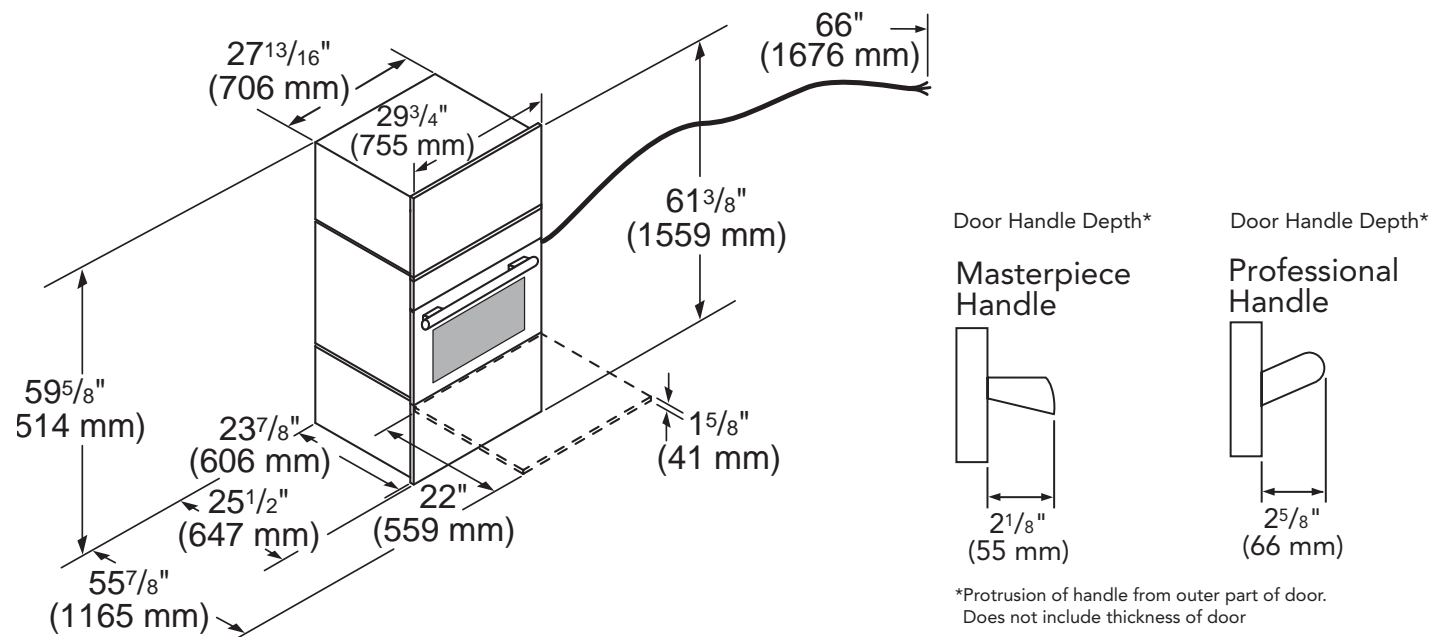

30-INCH AND 27-INCH TRIPLE COMBINATION BUILT-IN OVENS INSTALLATION

30-INCH TRIPLE COMBINATION OVEN WITH MICROWAVE AND WARMING DRAWER WALL-MOUNTED INSTALLATION

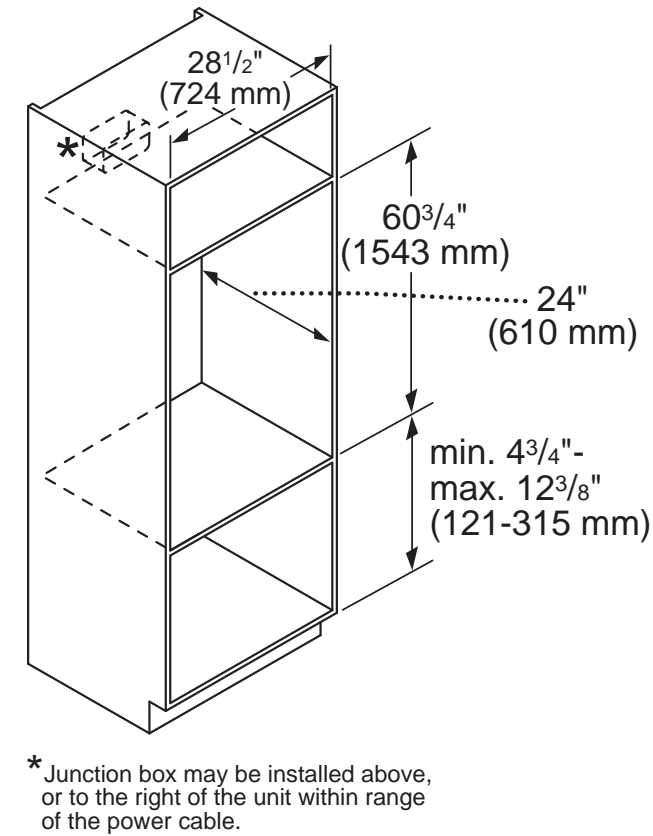

27-INCH TRIPLE COMBINATION OVEN WITH MICROWAVE WALL-MOUNTED INSTALLATION

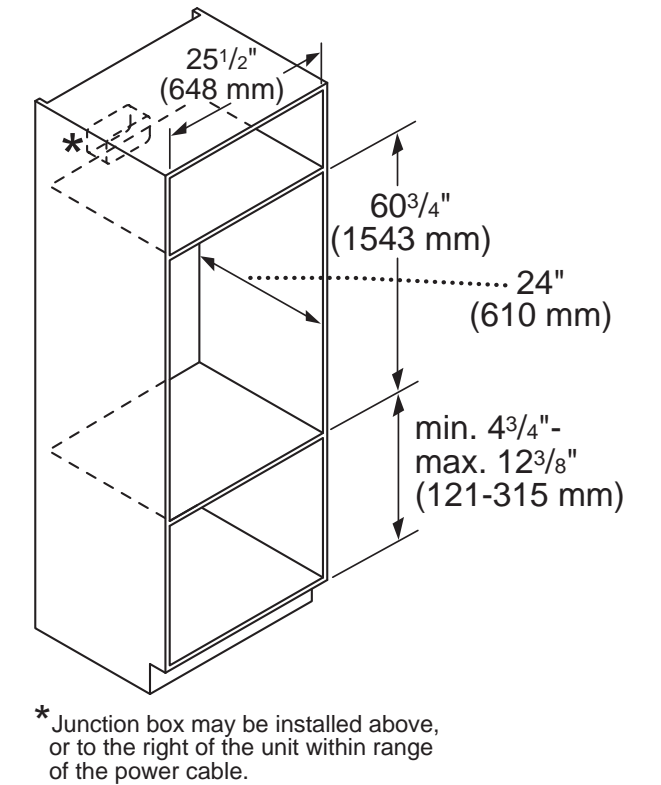

27-INCH TRIPLE COMBINATION OVEN WITH MICROWAVE

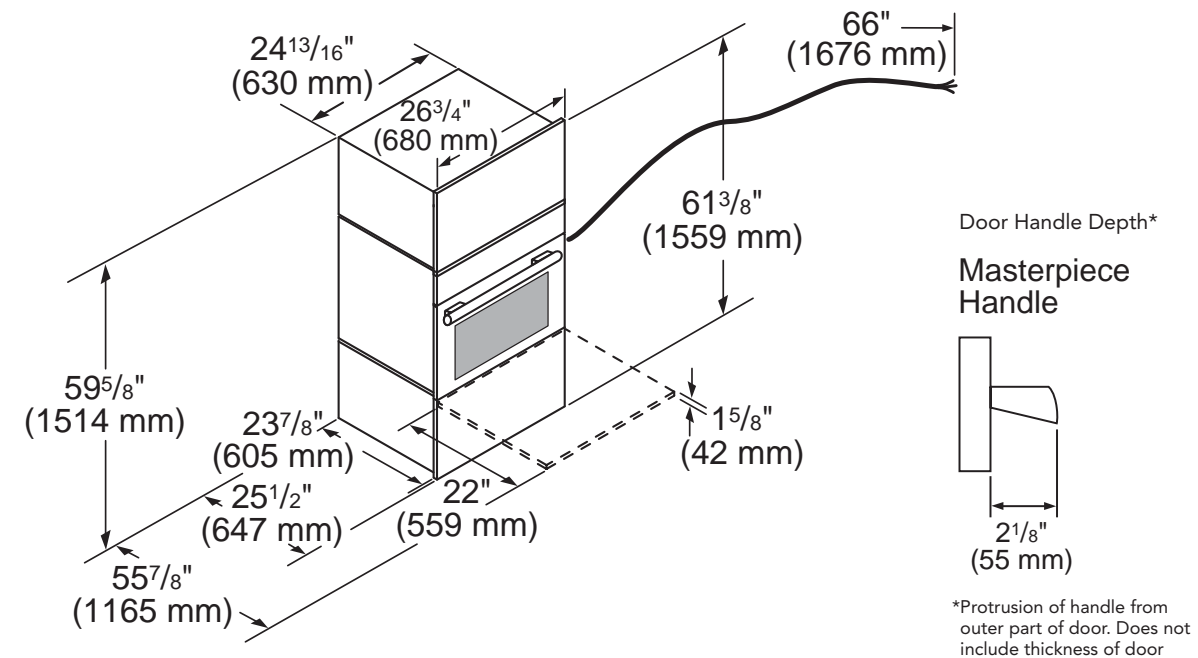



Thermador ★

INDUCTION COOKTOPS

MASTERPIECE® SERIES

More cooking options. More flexibility. More exceptional. Thermador offers the most innovative induction cooktop collection in the luxury market, leading the way with three distinct product lines. Available in sleek designs to complement any kitchen, each cooktop provides unmatched precision for even the most challenging recipes, offering more means of control, movement and personalization with frame and glass color options. With Thermador Induction Cooktops, you have the power to prepare for everything from intimate dinners to grand parties—all you need to add is ambition.



Freedom® Full Surface Induction Cooktops

FEATURE HIGHLIGHTS

★ ONE-OF-A-KIND INNOVATION

With over 30 international patents, the Freedom® Induction Cooktop represents a leap forward in induction cooking completely unique to Thermador®.

★ ANYWHERE, ANY POSITION

Place up to 4 pots or pans anywhere on the cooktop surface, in any configuration. The cooking surface is optimized to work with a pan as small as 3" and as large as 13" x 21".

★ FREEDOM TO MOVE

The Freedom® Induction cooking surface automatically detects the presence of your cookware. If you need to move your pot to another location, the cooktop will transfer all of your programmed settings to the new position of the pan.

★ LARGEST COOKING SURFACE

The Freedom® Induction Cooktop delivers 63% more usable surface area than the competition, with 48 coils measuring 3" each—offering the largest cooking surface on the market.

★ POWERBOOST®

To bring foods to the desired temperature in the shortest possible time, the PowerBoost function will deliver a maximum power output from 3,600W to 4,600W, among the most powerful in its class.

★ BRILLIANT INTERFACE

The induction control panel features a full-color touch screen, clear text displays, cookware display, and an easy-to-clean touch-through-glass interface. Our intuitive interface offers better control and faster access to cooking settings.

SAFETY / CLEAN LOCK

A critical feature for a touch-screen interface, Clean Lock prevents unwanted changes to your cooking settings.



Liberty™

Induction Cooktops

FEATURE HIGHLIGHTS

★ LIBERTY HEATSHIFT™ (NEW)

Thermador HeatShift allows you to change the power level by simply moving the pot across the cooking zone. Perfect for recipes that require multiple heat levels, such as moving from a sauté to a simmer.

★ LIBERTY MOVEMODE™ (NEW)

Finished cooking the main course and ready to prepare the sauce? MoveMode allows easy transfer of settings without having to reset power levels when moving a pot across the cooktop.

★ LIBERTY PANBOOST™ (NEW)

Ideal for cooking with oil in a pan, PanBoost technology provides 30 seconds of maximum power, then automatically lowers heat to continue cooking.

★ LIBERTY COOKSMART®

Get consistent results for even the most complex recipes. Cooksmart includes 5 preset frying levels so each dish as exceptional as the last.

LIBERTY STOPWATCH TIMER

Rather than counting down, this timer counts up to indicate how much time has passed since a meal has been cooking.

★ THERMADOR® EXCLUSIVE





CIT36XKB
36-INCH FREEDOM® INDUCTION COOKTOP
 MASTERPIECE® SERIES, DARK GRAY GLASS WITH STAINLESS STEEL FRAME



Also Available:
 CIT36XKBB - Dark Gray Glass, Frameless

GENERAL PROPERTIES

Controls	Touch Controls
----------	----------------

ELEMENT PERFORMANCE

Power of Full Surface Heating Element	3,600 W
Power of Full Surface Heating Element (In Boost)	4,600 W
Burners With Booster	All

COOKWARE SIZE (MAXIMUM 4 POTS)

Minimum Cookware Size*	3" x 3"
Maximum Cookware Size*	13" x 21"

TECHNICAL DETAILS

Watts (W)	7,200 W
Circuit Breaker (A)	40 A
Volts (V)	208 / 240 V
Frequency (Hz)	50 / 60 Hz
Plug Type	No Plug
Conduit	37" Flexible 3-Wire
Energy Source	Electric

DIMENSIONS & WEIGHT

Overall Appliance Dimensions (HxWxD) (in)	3 7/8" + 3 7/8" x 37" x 21 1/4"
Required Cutout Size (HxWxD) (in)	3 7/8" x 34 3/4" x 20"
Minimum Distance From Counter Front (in)	2 1/2"
Minimum Distance From Rear Wall (in)	2 3/8"
Net Weight (lbs)	69 lbs

WARRANTY

Limited Warranty, Entire Appliance, Parts and Labor	2 Year
---	--------

* Cookware less than 3" will not be recognized. Theoretical maximum cookware size is 13" x 27". Cookware must have a flat bottom in order to utilize the full surface.

FEATURES & BENEFITS

- ★ - Largest fully usable cooking surface on the market
- ★ - 48 induction elements deliver more than 63% usable cooking surface than the competition
- ★ - Place up to 4 pots or pans anywhere on the cooktop surface in any configuration. If you need to move your pot to another location, the cooktop will transfer all of your programmed settings to the new position of the pan.
- ★ - Featuring the first full color touchscreen induction user interface on the market, offering better control and faster access to cooking settings
- ★ - One of the most powerful elements in its class with a 4,600 W PowerBoost® lets you boil water faster than with any other cooking technology

ACCESSORIES (OPTIONAL)



Heritage
Induction Cooktops
FEATURE HIGHLIGHTS

★ **13-INCH TRIPLE ELEMENT**

Cooking is now three times more intuitive. The 13-inch Triple Element—the largest and most powerful in its class—activates induction levels based on the size of your cookware.

★ **SILVER MIRROR FINISH**

In addition to black, we offer a stunning silver mirrored finish to create a unique design statement for the contemporary kitchen.

★ **5,500W POWERBOOST®**

PowerBoost gets your cookware to a higher temperature faster, so you can quickly boil water for pasta or heat oil before sautéing.

SUPERIOR RESPONSIVENESS

Induction technology allows instantaneous temperature changes as the power level is adjusted, making it as responsive and flexible as gas cooktops.

TIMERS FOR ALL ELEMENTS

Each burner features its own element shut-off timer, making it easier to coordinate the cooking of multiple dishes.

★ **THERMADOR® EXCLUSIVE**

★ **THERMADOR® EXCLUSIVE**



CIT36XKBB

36-INCH FREEDOM® INDUCTION COOKTOP

MASTERPIECE® SERIES, DARK GRAY GLASS, FRAMELESS



Also Available:
CIT36XKB - Dark Gray Glass with Stainless Steel Frame

FEATURES & BENEFITS

- ★ - Largest fully usable cooking surface on the market
- ★ - 48 induction elements deliver more than 63% usable cooking surface than the competition
- ★ - Place up to 4 pots or pans anywhere on the cooktop surface in any configuration. If you need to move your pot to another location, the cooktop will transfer all of your programmed settings to the new position of the pan.
- ★ - Featuring the first full color touchscreen induction user interface on the market, offering better control and faster access to cooking settings
- ★ - One of the most powerful elements in its class with a 4,600 W PowerBoost® lets you boil water faster than with any other cooking technology

ACCESSORIES (OPTIONAL)



CHEFSPAN13
16" Round Skillet



TEPPAN1321
Griddle Style Teppanyaki
13" x 21"



TEPPAN1314
Griddle Style Teppanyaki
13" x 14"

GENERAL PROPERTIES

Controls	Touch Controls
----------	----------------

ELEMENT PERFORMANCE

Power of Full Surface Heating Element	3,600 W
Power of Full Surface Heating Element (In Boost)	4,600 W
Burners With Booster	All

COOKWARE SIZE (MAXIMUM 4 POTS)

Minimum Cookware Size*	3" x 3"
Maximum Cookware Size*	13" x 21"

TECHNICAL DETAILS

Watts (W)	7,200 W
Circuit Breaker (A)	40 A
Volts (V)	208 / 240 V
Frequency (Hz)	50 / 60 Hz
Plug Type	No Plug
Conduit	37" Flexible 3-Wire
Energy Source	Electric

DIMENSIONS & WEIGHT

Overall Appliance Dimensions (HxWxD) (in)	3/8"+3 7/8" x 37" x 21 1/4"
Required Cutout Size (HxWxD) (in)	3 7/8" x 34 7/8" x 20"
Minimum Distance From Counter Front (in)	2 1/2"
Minimum Distance From Rear Wall (in)	2 3/8"
Net Weight (lbs)	50 lbs

WARRANTY

Limited Warranty, Entire Appliance, Parts and Labor	2 Year
---	--------

* Cookware less than 3" will not be recognized. Theoretical maximum cookware size is 13" x 27". Cookware must have a flat bottom in order to utilize the full surface.

CIT367TGS

36-INCH LIBERTY™ INDUCTION COOKTOP

MASTERPIECE® SERIES, TITANIUM GRAY GLASS WITH STAINLESS STEEL FRAME



Also Available:
CIT367TG - Titanium Gray Glass, Frameless
CIT367TM - Silver Mirrored Finish, Frameless
CIT367TMS - Silver Mirrored Finish with Stainless Steel Frame

FEATURES & BENEFITS

- ★ - 3 extra-large Liberty™ cooking zones allows more space and flexibility in placing larger cookware
- ★ - HeatShift™ feature has three preset heat zones that allows you to change the power level by simply moving the pot across the cooking zone
- ★ - MoveMode™ feature allows easy transfer of settings without having to reset power levels when moving a pot across the cooktop
- ★ - CookSmart® with 5 pre-set temperature levels to effortlessly pan fry a wide range of foods
- Illuminated touch control panel offers intuitively simple selection of 17 power levels and allows for easy cleaning

ACCESSORIES (OPTIONAL)



CHEFSPAN08
10" Stainless Steel Pan



TEPPAN1013
Griddle Style Teppanyaki
10" x 13"



TEPPAN1016
Griddle Style Teppanyaki
10" x 16"



TROASTERT
Stainless Steel Roaster Pan

GENERAL PROPERTIES

Controls	Touch Controls
----------	----------------

ELEMENT PERFORMANCE

Power of Full Surface Heating Element	2,200 W
Power of Full Surface Heating Element (In Boost)	3,700 W
Power of Front Left Heating Element	2,200 W
Power of Front Left Heating Element (In Boost)	3,600 W
Power of Back Left Heating Element	2,200 W
Power of Back Left Heating Element (In Boost)	3,600 W
Power of Center Heating Element	3,300 W
Power of Center Heating Element (In Boost)	3,700 W
Power of Front Right Heating Element	2,200 W
Power of Front Right Heating Element (In Boost)	3,600 W
Power of Back Right Heating Element	2,200 W
Power of Back Right Heating Element (In Boost)	3,600 W
Burners With Booster	All 5

ELEMENT SIZE

Dimension of Front Left Heating Element	7 1/2" x 9"
Dimension of Back Left Heating Element	7 1/2" x 9"
Dimension of Center Heating Element	11 1/4" x 9 1/2"
Dimension of Back Right Heating Element	7 1/2" x 9"
Dimension of Front Right Heating Element	7 1/2" x 9"

TECHNICAL DETAILS

Watts (W)	11,100 W
Circuit Breaker (A)	50 A
Volts (V)	208 / 240 V
Frequency (Hz)	50 / 60 Hz
Plug Type	No Plug
Conduit	39" Flexible 3-Wire
Energy Source	Electric

DIMENSIONS & WEIGHT

Overall Appliance Dimensions (HxWxD) (in)	3/8"+3 7/8" x 37" x 21 1/4"
Required Cutout Size (HxWxD) (in)	3 7/8" x 34 3/4" x 19 7/8"
Minimum Distance From Counter Front (in)	2 1/2"
Minimum Distance From Rear Wall (in)	2 3/8"
Net Weight (lbs)	55 lbs

WARRANTY

Limited Warranty, Entire Appliance, Parts and Labor	2 Year
---	--------

CIT367TG

36-INCH LIBERTY™ INDUCTION COOKTOP

MASTERPIECE® SERIES, TITANIUM GRAY GLASS, FRAMELESS

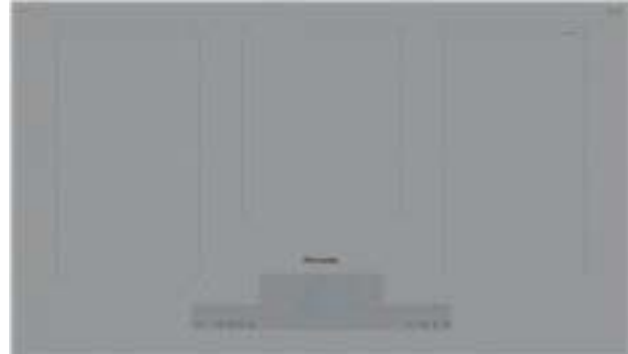

Also Available:
 CIT367TGS - Titanium Gray Glass with Stainless Steel Frame
 CIT367TM - Silver Mirrored Finish, Frameless
 CIT367TMS - Silver Mirrored Finish with Stainless Steel Frame

FEATURES & BENEFITS

- ★ 3 extra-large Liberty™ cooking zones allows more space and flexibility in placing larger cookware
- ★ HeatShift™ feature has three preset heat zones that allows you to change the power level by simply moving the pot across the cooking zone
- ★ MoveMode™ feature allows easy transfer of settings without having to reset power levels when moving a pot across the cooktop
- ★ CookSmart® with 5 pre-set temperature levels to effortlessly pan fry a wide range of foods
 - Illuminated touch control panel offers intuitively simple selection of 17 power levels and allows for easy cleaning

ACCESSORIES (OPTIONAL)

-  CHEFSPAN08
10" Stainless Steel Pan
-  TEPPAN1013
Griddle Style Teppanyaki
10" x 13"
-  TEPPAN1016
Griddle Style Teppanyaki
10" x 16"
-  TROASTERT
Stainless Steel Roaster Pan

GENERAL PROPERTIES

Controls	Touch Controls
----------	----------------

ELEMENT PERFORMANCE

Power of Full Surface Heating Element	2,200 W
Power of Full Surface Heating Element (In Boost)	3,700 W
Power of Front Left Heating Element	2,200 W
Power of Front Left Heating Element (In Boost)	3,600 W
Power of Back Left Heating Element	2,200 W
Power of Back Left Heating Element (In Boost)	3,600 W
Power of Center Heating Element	3,300 W
Power of Center Heating Element (In Boost)	3,700 W
Power of Front Right Heating Element	2,200 W
Power of Front Right Heating Element (In Boost)	3,600 W
Power of Back Right Heating Element	2,200 W
Power of Back Right Heating Element (In Boost)	3,600 W
Burners With Booster	All 5

ELEMENT SIZE

Dimension of Front Left Heating Element	7 1/2" x 9"
Dimension of Back Left Heating Element	7 1/2" x 9"
Dimension of Center Heating Element	11 1/4" x 9 1/2"
Dimension of Back Right Heating Element	7 1/2" x 9"
Dimension of Front Right Heating Element	7 1/2" x 9"

TECHNICAL DETAILS

Watts (W)	11,100 W
Circuit Breaker (A)	50 A
Volts (V)	208 / 240 V
Frequency (Hz)	50 / 60 Hz
Plug Type	No Plug
Conduit	39" Flexible 3-Wire
Energy Source	Electric

DIMENSIONS & WEIGHT

Overall Appliance Dimensions (HxWxD) (in)	3/8"+3 7/8" x 37" x 21 1/4"
Required Cutout Size (HxWxD) (in)	3 7/8" x 34 3/4" x 19 7/8"
Minimum Distance From Counter Front (in)	2 1/2"
Minimum Distance From Rear Wall (in)	2 3/8"
Net Weight (lbs)	55 lbs

WARRANTY

Limited Warranty, Entire Appliance, Parts and Labor	2 Year
---	--------

CIT367TMS

36-INCH LIBERTY™ INDUCTION COOKTOP

MASTERPIECE® SERIES, SILVER MIRRORING FINISH WITH STAINLESS STEEL FRAME



AVAILABLE 2018

Also Available:
 CIT367TG - Titanium Gray Glass, Frameless
 CIT367TGS - Titanium Gray Glass with Stainless Steel Frame
 CIT367TM - Silver Mirrored Finish, Frameless

FEATURES & BENEFITS

- ★ 3 extra-large Liberty™ cooking zones allows more space and flexibility in placing larger cookware
- ★ HeatShift™ feature has three preset heat zones that allows you to change the power level by simply moving the pot across the cooking zone
- ★ MoveMode™ feature allows easy transfer of settings without having to reset power levels when moving a pot across the cooktop
- ★ Silver mirrored finish creates a stunning and unique design statement for the contemporary kitchen
 - Illuminated touch control panel offers intuitively simple selection of 17 power levels and allows for easy cleaning

ACCESSORIES (OPTIONAL)

-  CHEFSPAN08
10" Stainless Steel Pan
-  TEPPAN1013
Griddle Style Teppanyaki
10" x 13"
-  TEPPAN1016
Griddle Style Teppanyaki
10" x 16"
-  TROASTERT
Stainless Steel Roaster Pan

GENERAL PROPERTIES

Controls	Touch Controls
----------	----------------

ELEMENT PERFORMANCE

Power of Full Surface Heating Element	2,200 W
Power of Full Surface Heating Element (In Boost)	3,700 W
Power of Front Left Heating Element	2,200 W
Power of Front Left Heating Element (In Boost)	3,600 W
Power of Back Left Heating Element	2,200 W
Power of Back Left Heating Element (In Boost)	3,600 W
Power of Center Heating Element	3,300 W
Power of Center Heating Element (In Boost)	3,700 W
Power of Front Right Heating Element	2,200 W
Power of Front Right Heating Element (In Boost)	3,600 W
Power of Back Right Heating Element	2,200 W
Power of Back Right Heating Element (In Boost)	3,600 W
Burners With Booster	All 5

ELEMENT SIZE

Dimension of Front Left Heating Element	7 1/2" x 9"
Dimension of Back Left Heating Element	7 1/2" x 9"
Dimension of Center Heating Element	11 1/4" x 9 1/2"
Dimension of Back Right Heating Element	7 1/2" x 9"
Dimension of Front Right Heating Element	7 1/2" x 9"

TECHNICAL DETAILS

Watts (W)	11,100 W
Circuit Breaker (A)	50 A
Volts (V)	208 / 240 V
Frequency (Hz)	50 / 60 Hz
Plug Type	No Plug
Conduit	39" Flexible 3-Wire
Energy Source	Electric

DIMENSIONS & WEIGHT

Overall Appliance Dimensions (HxWxD) (in)	1/4"+4" x 37" x 21 1/4"
Required Cutout Size (HxWxD) (in)	4" x 34 7/8" x 19 7/8"
Minimum Distance From Counter Front (in)	2 1/2"
Minimum Distance From Rear Wall (in)	2 3/8"
Net Weight (lbs)	52 lbs

WARRANTY

Limited Warranty, Entire Appliance, Parts and Labor	2 Year
---	--------

CIT367TM

36-INCH LIBERTY™ INDUCTION COOKTOP

MASTERPIECE® SERIES, SILVER MIRRORED FINISH, FRAMELESS



AVAILABLE 2018

Also Available:

- CIT367TG - Titanium Gray Glass, Frameless
- CIT367TGS - Titanium Gray Glass with Stainless Steel Frame
- CIT367TMS - Silver Mirrored Finish with Stainless Steel Frame

FEATURES & BENEFITS

- ★ 3 extra-large Liberty™ cooking zones allows more space and flexibility in placing larger cookware
- ★ HeatShift™ feature has three preset heat zones that allows you to change the power level by simply moving the pot across the cooking zone
- ★ MoveMode™ feature allows easy transfer of settings without having to reset power levels when moving a pot across the cooktop
- ★ Silver mirrored finish creates a stunning and unique design statement for the contemporary kitchen
 - Illuminated touch control panel offers intuitively simple selection of 17 power levels and allows for easy cleaning

ACCESSORIES (OPTIONAL)

-  CHEFSPAN08
10" Stainless Steel Pan
-  TEPPAN1013
Griddle Style Teppanyaki
10" x 13"
-  TEPPAN1016
Griddle Style Teppanyaki
10" x 16"
-  TROASTERT
Stainless Steel Roaster Pan

GENERAL PROPERTIES

Controls	Touch Controls
----------	----------------

ELEMENT PERFORMANCE

Power of Full Surface Heating Element	2,200 W
Power of Full Surface Heating Element (In Boost)	3,700 W
Power of Front Left Heating Element	2,200 W
Power of Front Left Heating Element (In Boost)	3,600 W
Power of Back Left Heating Element	2,200 W
Power of Back Left Heating Element (In Boost)	3,600 W
Power of Center Heating Element	3,300 W
Power of Center Heating Element (In Boost)	3,700 W
Power of Front Right Heating Element	2,200 W
Power of Front Right Heating Element (In Boost)	3,600 W
Power of Back Right Heating Element	2,200 W
Power of Back Right Heating Element (In Boost)	3,600 W
Burners With Booster	All 5

ELEMENT SIZE

Dimension of Front Left Heating Element	7 1/2" x 9"
Dimension of Back Left Heating Element	7 1/2" x 9"
Dimension of Center Heating Element	11 1/4" x 9 1/2"
Dimension of Back Right Heating Element	7 1/2" x 9"
Dimension of Front Right Heating Element	7 1/2" x 9"

TECHNICAL DETAILS

Watts (W)	11,100 W
Circuit Breaker (A)	50 A
Volts (V)	208 / 240 V
Frequency (Hz)	50 / 60 Hz
Plug Type	No Plug
Conduit	39" Flexible 3-Wire
Energy Source	Electric

DIMENSIONS & WEIGHT

Overall Appliance Dimensions (HxWxD) (in)	1/4"+4" x 37" x 21 1/4"
Required Cutout Size (HxWxD) (in)	4" x 34 7/8" x 19 7/8"
Minimum Distance From Counter Front (in)	2 1/2"
Minimum Distance From Rear Wall (in)	2 3/8"
Net Weight (lbs)	52 lbs

WARRANTY

Limited Warranty, Entire Appliance, Parts and Labor	2 Year
---	--------

CIT365KM

36-INCH INDUCTION COOKTOP

MASTERPIECE® SERIES, SILVER MIRRORED FINISH



FEATURES & BENEFITS

- ★ Silver Mirrored Finish—striking and bold design offers the perfect companion solution for stainless steel products
- ★ Largest (13") round heating element on the market in its class and among the most powerful (4,600 W)
- ★ Industry exclusive triple zone—accommodates multiple size pans with 3 diameter sizes
 - Speed heating induction cooktops heat faster than traditional gas and electric cooktops
 - Touch control panel with blue light illumination offers 17 power settings

ACCESSORIES (OPTIONAL)

-  CHEFSPAN13
16" Round Skillet
-  CHEFSPAN08
10" Stainless Steel Pan

GENERAL PROPERTIES

Controls	Touch Controls
----------	----------------

ELEMENT PERFORMANCE

Power of Front Left Heating Element	1,800 W
Power of Front Left Heating Element (In Boost)	2,500 W
Power of Back Left Heating Element	1,800 W
Power of Back Left Heating Element (In Boost)	2,500 W
Power of Center Heating Element	3,300 / 2,600 / 2,200 W
Power of Center Heating Element (In Boost)	4,600 / 3,400 / 3,300 W
Power of Back Right Heating Element	1,400 W
Power of Back Right Heating Element (In Boost)	1,800 W
Power of Front Right Heating Element	2,200 W
Power of Front Right Heating Element (In Boost)	3,700 W
Burners With Booster	All 5

ELEMENT SIZE

Dimension of Front Left Heating Element	7"
Dimension of Back Left Heating Element	7"
Dimension of Center Heating Element	13", 11", 9"
Dimension of Back Right Heating Element	6"
Dimension of Front Right Heating Element	9"

TECHNICAL DETAILS

Watts (W)	10,800 W
Circuit Breaker (A)	50 A
Volts (V)	208 / 240 V
Frequency (Hz)	50 / 60 Hz
Plug Type	No Plug
Conduit	37" Flexible 3-Wire
Energy Source	Electric

DIMENSIONS & WEIGHT

Overall Appliance Dimensions (HxWxD) (in)	1/4"+4" x 37" x 21 1/4"
Required Cutout Size (HxWxD) (in)	4" x 34 7/8" x 19 7/8"
Minimum Distance From Counter Front (in)	2 1/2"
Minimum Distance From Rear Wall (in)	2 3/8"
Net Weight (lbs)	51 lbs

WARRANTY

Limited Warranty, Entire Appliance, Parts and Labor	2 Year
---	--------

CIT365TB
36-INCH INDUCTION COOKTOP
 MASTERPIECE® SERIES, BLACK GLASS, FRAMELESS



FEATURES & BENEFITS

- ★ Large 13" round heating element and the most powerful (5,500 W) in its class
- ★ Industry exclusive triple zone element – allows you to match element size to various sized cookware
 - PowerBoost® feature increases element power by up to 50%, saving time to heat up pots or cook large quantities
 - Each element has its own shut-off timer, making it easier to coordinate the cooking of multiple dishes
 - Illuminated touch controls with 17 power settings is highly precise and allows for easy cleaning

ACCESSORIES (OPTIONAL)



CHEFSPAN13
16" Round Skillet



CHEFSPAN08
10" Stainless Steel Pan

GENERAL PROPERTIES	
Controls	Touch Controls
ELEMENT PERFORMANCE	
Power of Front Left Heating Element	1,800 W
Power of Front Left Heating Element (In Boost)	3,100 W
Power of Back Left Heating Element	1,800 W
Power of Back Left Heating Element (In Boost)	3,100 W
Power of Center Heating Element	3,300 / 2,600 / 2,200 W
Power of Center Heating Element (In Boost)	5,500 / 4,400 / 3,700 W
Power of Front Right Heating Element	2,200 W
Power of Front Right Heating Element (In Boost)	3,700 W
Power of Back Right Heating Element	1,400 W
Power of Back Right Heating Element (In Boost)	2,200 W
Burners With Booster	All 5
ELEMENT SIZE	
Dimension of Front Left Heating Element	7"
Dimension of Back Left Heating Element	7"
Dimension of Center Heating Element	13", 11", 9"
Dimension of Back Right Heating Element	6"
Dimension of Front Right Heating Element	9"
TECHNICAL DETAILS	
Watts (W)	11,100 W
Circuit Breaker (A)	50 A
Volts (V)	208 / 240 V
Frequency (Hz)	50 / 60 Hz
Plug Type	No Plug
Conduit	39" Flexible 3-Wire
Energy Source	Electric
DIMENSIONS & WEIGHT	
Overall Appliance Dimensions (HxWxD) (in)	3 7/8" + 3 7/8" x 37" x 21 1/4"
Required Cutout Size (HxWxD) (in)	3 7/8" x 34 3/4" x 19 7/8"
Minimum Distance From Counter Front (in)	2 1/2"
Minimum Distance From Rear Wall (in)	2 3/8"
Net Weight (lbs)	52 lbs
WARRANTY	
Limited Warranty, Entire Appliance, Parts and Labor	2 Year

CIT304KM
30-INCH INDUCTION COOKTOP
 MASTERPIECE® SERIES, SILVER MIRROR FINISH



FEATURES & BENEFITS

- ★ Silver Mirrored Finish—striking and bold design offers the perfect companion solution for stainless steel products
- ★ Our Induction PowerBoost® feature heats cookware faster than any other type of cooking technology
 - Large and powerful 11" element with 3,600 W
 - Speed heating induction cooktops heat faster than traditional gas and electric cooktops
 - Touch control panel with blue light illumination offers 17 power settings

ACCESSORIES (OPTIONAL)



CHEFSPAN08
10" Stainless Steel Pan

GENERAL PROPERTIES	
Controls	Touch Controls
ELEMENT PERFORMANCE	
Power of Front Left Heating Element	2,200 W
Power of Front Left Heating Element (In Boost)	3,700 W
Power of Back Left Heating Element	1,400 W
Power of Back Left Heating Element (In Boost)	1,800 W
Power of Center Heating Element	N/A
Power of Center Heating Element (In Boost)	N/A
Power of Back Right Heating Element	2,400 W
Power of Back Right Heating Element (In Boost)	3,600 W
Power of Front Right Heating Element	1,400 W
Power of Front Right Heating Element (In Boost)	1,800 W
Burners With Booster	All 4
ELEMENT SIZE	
Dimension of Front Left Heating Element	9"
Dimension of Back Left Heating Element	6"
Dimension of Center Heating Element	N/A
Dimension of Back Right Heating Element	11"
Dimension of Front Right Heating Element	6"
TECHNICAL DETAILS	
Watts (W)	7,200 W
Circuit Breaker (A)	40 A
Volts (V)	208 / 240 V
Frequency (Hz)	50 / 60 Hz
Plug Type	No Plug
Conduit	39" Flexible 3-Wire
Energy Source	Electric
DIMENSIONS & WEIGHT	
Overall Appliance Dimensions (HxWxD) (in)	1 1/4" + 4" x 31" x 21 1/4"
Required Cutout Size (HxWxD) (in)	4" x 28 3/4" x 19 7/8"
Minimum Distance From Counter Front (in)	2 1/2"
Minimum Distance From Rear Wall (in)	2 3/8"
Net Weight (lbs)	42 lbs
WARRANTY	
Limited Warranty, Entire Appliance, Parts and Labor	2 Year

CIT304TM

30-INCH INDUCTION COOKTOP

MASTERPIECE® SERIES, SILVER MIRRORED FINISH, FRAMELESS



Also Available: **AVAILABLE 2018**
CIT304TB - Black Glass, Frameless

FEATURES & BENEFITS

- Powerful 3,700 W, 11" element for larger pots and pans
- ★ Silver mirrored finish creates a stunning and unique design statement for the contemporary kitchen
- PowerBoost® feature increases element power by up to 50%, saving time to heat up pots or cook large quantities
- Each element has its own shut-off timer, making it easier to coordinate the cooking of multiple dishes
- Illuminated touch controls with 17 power settings is highly precise and allows for easy cleaning

ACCESSORIES (OPTIONAL)



CHEFSPAN08
10" Stainless Steel Pan

GENERAL PROPERTIES	
Controls	Touch Controls
ELEMENT PERFORMANCE	
Power of Front Left Heating Element	1,400 W
Power of Front Left Heating Element (In Boost)	2,200 W
Power of Back Left Heating Element	2,200 W
Power of Back Left Heating Element (In Boost)	3,700 W
Power of Center Heating Element	N/A
Power of Center Heating Element (In Boost)	N/A
Power of Front Right Heating Element	1,400 W
Power of Front Right Heating Element (In Boost)	2,200 W
Power of Back Right Heating Element	2,600 W
Power of Back Right Heating Element (In Boost)	3,700 W
Burners With Booster	All 4
ELEMENT SIZE	
Dimension of Front Left Heating Element	6"
Dimension of Back Left Heating Element	9"
Dimension of Center Heating Element	N/A
Dimension of Back Right Heating Element	11"
Dimension of Front Right Heating Element	6"
TECHNICAL DETAILS	
Watts (W)	7,200 W
Circuit Breaker (A)	30 A
Volts (V)	208 / 240 V
Frequency (Hz)	50 / 60 Hz
Plug Type	No Plug
Conduit	39" Flexible 3-Wire
Energy Source	Electric
DIMENSIONS & WEIGHT	
Overall Appliance Dimensions (HxWxD) (in)	1/4"+4" x 31" x 21 1/4"
Required Cutout Size (HxWxD) (in)	4" x 28 3/4" x 19 7/8"
Minimum Distance From Counter Front (in)	2 1/2"
Minimum Distance From Rear Wall (in)	2 3/8"
Net Weight (lbs)	41 lbs
WARRANTY	
Limited Warranty, Entire Appliance, Parts and Labor	2 Year

CIT304TB

30-INCH INDUCTION COOKTOP

MASTERPIECE® SERIES BLACK GLASS, FRAMELESS



Also Available:
CIT304TM - Silver Mirrored Finish, Frameless

FEATURES & BENEFITS

- Powerful 3,700 W, 11" element for larger pots and pans
- Induction cooktops heat faster than traditional gas and electric cooktops
- PowerBoost® feature increases element power by up to 50%, saving time to heat up pots or cook large quantities
- Each element has its own shut-off timer, making it easier to coordinate the cooking of multiple dishes
- Illuminated touch controls with 17 power settings is highly precise and allows for easy cleaning

ACCESSORIES (OPTIONAL)



CHEFSPAN08
10" Stainless Steel Pan

GENERAL PROPERTIES	
Controls	Touch Controls
ELEMENT PERFORMANCE	
Power of Front Left Heating Element	1,400 W
Power of Front Left Heating Element (In Boost)	2,200 W
Power of Back Left Heating Element	2,200 W
Power of Back Left Heating Element (In Boost)	3,700 W
Power of Center Heating Element	N/A
Power of Center Heating Element (In Boost)	N/A
Power of Front Right Heating Element	1,400 W
Power of Front Right Heating Element (In Boost)	2,200 W
Power of Back Right Heating Element	2,600 W
Power of Back Right Heating Element (In Boost)	3,700 W
Burners With Booster	All 4
ELEMENT SIZE	
Dimension of Front Left Heating Element	6"
Dimension of Back Left Heating Element	9"
Dimension of Center Heating Element	N/A
Dimension of Back Right Heating Element	11"
Dimension of Front Right Heating Element	6"
TECHNICAL DETAILS	
Watts (W)	7,200 W
Circuit Breaker (A)	30 A
Volts (V)	208 / 240 V
Frequency (Hz)	50 / 60 Hz
Plug Type	No Plug
Conduit	39" Flexible 3-Wire
Energy Source	Electric
DIMENSIONS & WEIGHT	
Overall Appliance Dimensions (HxWxD) (in)	3/8"+3 7/8" x 31" x 21 1/4"
Required Cutout Size (HxWxD) (in)	3 7/8" x 28 3/4" x 19 7/8"
Minimum Distance From Counter Front (in)	2 1/2"
Minimum Distance From Rear Wall (in)	2 3/8"
Net Weight (lbs)	40 lbs
WARRANTY	
Limited Warranty, Entire Appliance, Parts and Labor	2 Year

INDUCTION COOKTOPS

PLANNING INFORMATION

MODEL OPTIONS

There are two sizes of induction cooktops to choose from—30-inch and 36-inch. Models are available in our original black finish as well as our silver mirrored finish for those who want a bold, striking alternative that goes perfectly with stainless steel appliances. Be sure to reference the correct model information in this design guide.

INSTALLATION CONSIDERATIONS

The information in this design guide provides key features, product dimensions, cutouts and installation specifications. Before installing a Thermador Induction Cooktop, be sure to verify the cutout dimensions and electrical connections. Also, always consult with the installation manual packed with the product for complete details before installing.

Selected 36-inch Thermador Induction Cooktops may be installed above a Thermador Single Built-in Oven. A minimum 1" air gap must be maintained between the bottom of the cooktop and the top of the oven. See below for approved cooktop over oven installation.

MODEL	APPROVED COOKTOP OVER THERMADOR OVEN INSTALLATION
CIT36XKB	•
CIT36XKBB	•
CIT367TGS	
CIT367TG	
CIT367TMS	
CIT367TM	
CIT365KM	•
CIT365TB	
CIT304KM	
CIT304TM	
CIT304TB	

Cooktops that are not listed above, must be approved under local code and / or by the local authority having jurisdictions.

Thermador Cooktops may also be installed above a Thermador Warming Drawer to create a convenient cooking center. Refer to the warming drawer section for additional specifications.

IMPORTANT

We strongly recommend the installation of a Thermador Ventilation System with this induction cooktop.

Seal the surfaces of the cutout to make them heat resistant. This prevents the surfaces from expanding as a result of humidity. Solid surface countertops often require special installation. For example, heat reflective tape or rounded corners may be necessary. Contact the countertop manufacturer for instructions specific to your countertop.

WARNING

To reduce the risk of ignition of nearby combustible materials, install the countertop with a minimum distance of 2" (51 mm) from both side walls and the back wall.

ELECTRICAL SPECIFICATIONS

Be sure your appliance is properly installed and grounded by a qualified technician. Installation, electrical connections and grounding must comply with all applicable local codes.

All induction cooktops are dual rated, designed to be connected to either 240 / 208V AC, 60 Hz, 3-wire, single-phase power supply.

Install a suitable conduit box (not furnished). An appropriately-sized, UL-listed conduit connector must be used to correctly attach the conduit to the junction box.

MODEL	REQUIRED CIRCUIT BREAKER
	240 / 208V, 3-Wire, 50 / 60 Hz
CIT36XKB	40 A
CIT36XKBB	40 A
CIT367TGS	50 A
CIT367TG	50 A
CIT367TMS	50 A
CIT367TM	50 A
CIT365KM	50 A
CIT365TB	50 A
CIT304KM	40 A
CIT304TM	30 A
CIT304TB	30 A

IMPORTANT: Local Codes may vary; installation, electrical connections and grounding must comply with all applicable local codes. If required by the National Electrical Code (or Canadian Electrical Code), this appliance must be installed on a separate branch circuit.

ELECTRICAL LOCATION

The junction box must be located within 3 feet (~900 mm) of the cooktop connection. It should be easily accessible for service purposes.

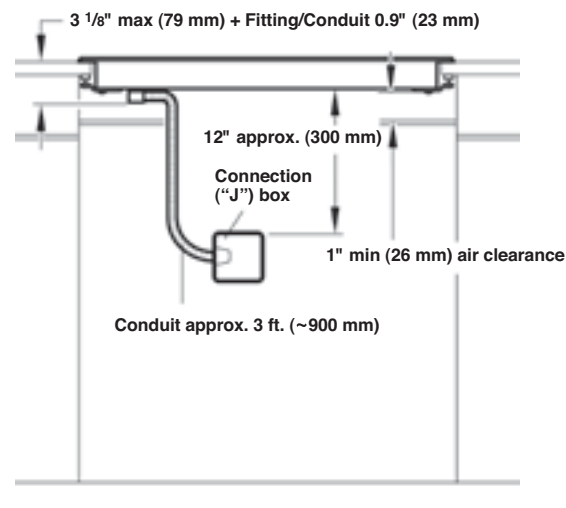

36-INCH COOKTOP AND CUTOUT DIMENSIONS

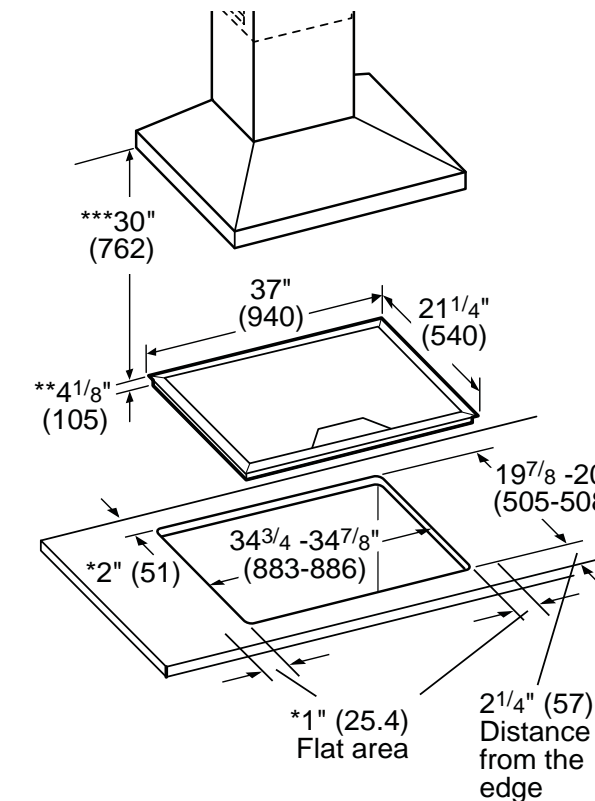

- * Minimum distance from the cutout to the wall
 - ** Installed depth includes 1" (26 mm) air clearance
 - *** Minimum distance between surface of the cooktop and lower edge of the exhaust hood.
- Measurements in inches(mm in brackets)

NOTE: The work surface should be horizontal and level. The stability of the countertop should be confirmed even after making the cutout.

HEAT SHIELD

The heat shield will require an additional 1" clearance below the cooktop. For safety reasons, the heat shield must be properly installed. This prevents components from overheating as a result of the recirculation of hot air from the cooktop. The heat shield is the same width as the cooktop. For shipping, it is screwed to the burner box. Once installed, the heat shield will be able to rotate freely, as shown in the illustration. Refer to the instructions packed with product for installation details.

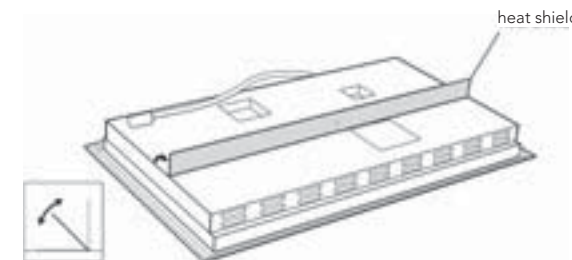

INDUCTION COOKTOPS

INSTALLATION

36-INCH COOKTOP INSTALLATION ABOVE A THERMADOR BUILT-IN OVEN (CIT36XKB, CIT36XKBB, CIT365KM ONLY)

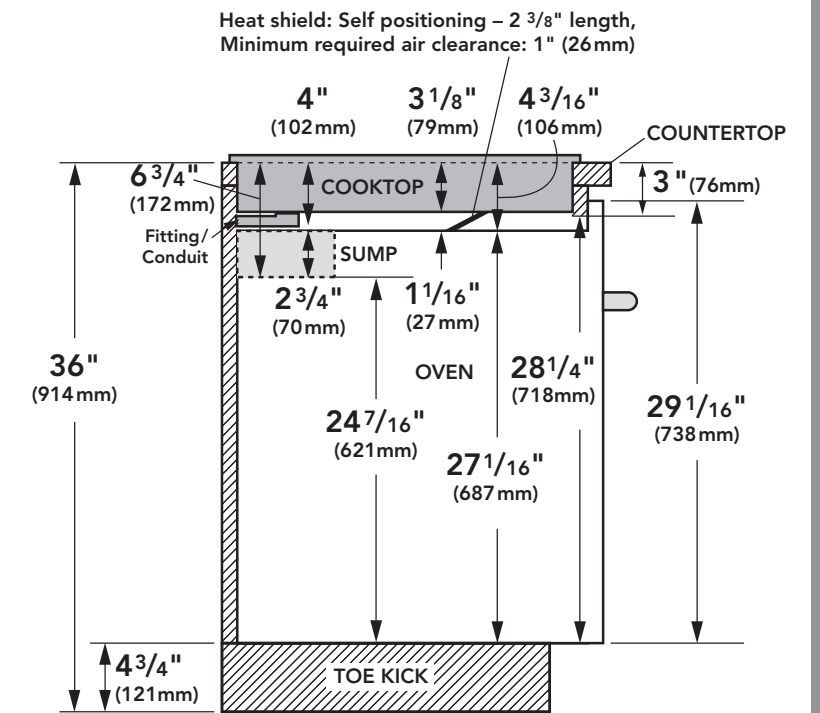

Note: Dimensions based on standard countertop height (36" with 4 3/4" toe kick including base plate).

The built-in oven can be installed below the induction cooktop as long as there is an air clearance of 1" between the bottom of the cooktop and the top of the oven.

Sump applies to 30-inch Wall Ovens only.

IMPORTANT: ONLY SELECTED THERMADOR 36" INDUCTION COOKTOPS ARE APPROVED TO BE INSTALLED ABOVE WALL OVENS. SEE PAGE 170 FOR LISTING OF APPROVED MODELS.

INDUCTION COOKTOPS INSTALLATION

30-INCH COOKTOP AND CUTOUT DIMENSIONS

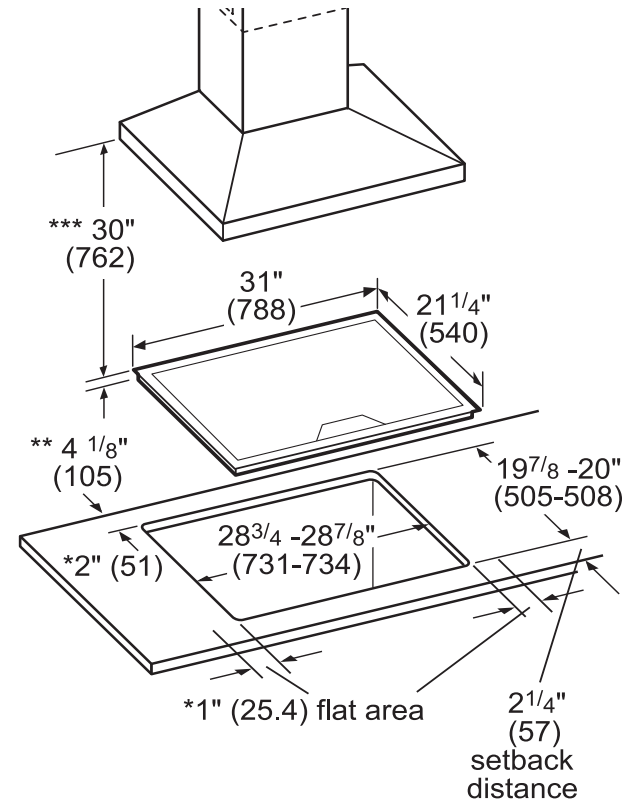

- * Minimum distance from cutout to the wall
- ** Installed depth includes 1" (26 mm) needed air gap
- *** Minimum distance between the cooktop surface and lower edge of exhaust hood

measurements in inches (mm in brackets)

NOTE: The work surface should be horizontal and level. The stability of the countertop should be confirmed even after making the cutout.

IMPORTANT: THERMADOR 30" INDUCTION COOKTOPS ARE NOT APPROVED TO BE INSTALLED ABOVE WALL OVENS.



MODEL SHOWN: CIT367TGS MASTERPIECE® SERIES LIBERTY™ INDUCTION COOKTOP



Thermador 

GAS COOKTOPS

MASTERPIECE® SERIES

Thermador® is lighting a heavenly fire under the status quo with the most powerful, award-winning gas cooktop in the luxury market. The Star® Burner is perhaps the single most iconic innovation from Thermador. But the star shape isn't just for show. The Star Burner delivers superior flame spread and a reduced cold spot for faster and more even heating. With 30-inch and 36-inch models to choose from featuring up to five Star Burners, there's a Masterpiece® Gas Cooktop designed to satisfy any cooking enthusiast or kitchen configuration.

The Cooktop All Other COOKTOPS WANT TO BE

★ OUR EXCLUSIVE, PATENTED STAR® BURNER

The Star Burner's unique shape isn't just for show. The Star delivers 56% more coverage with superior flame spread and a reduced cold spot for faster and more even heating across any size pan.



The Star Burner's coverage area allows for more ports and more flame distribution than a round burner.

Star Burner: 35 ports / 16 3/4" perimeter

Conventional Burner: 28 ports / 10 3/4" perimeter

★ THE MOST POWERFUL 30-INCH GAS COOKTOP

Thermador® offers an impressive 30-inch gas cooktop with 5 burners, including a center-mounted power burner, and 52,000 BTUs of overall heat output. This gives you the functionality of a 36-inch cooktop in a compact kitchen environment.

★ THERMADOR® EXCLUSIVE



Gas Cooktops FEATURE HIGHLIGHTS

★ EXTRALOW® BURNERS

A Thermador® exclusive, this setting cycles the burner on and off to maintain 200 BTU / hr, perfect for melting chocolate or heating delicate sauces.

★ ILLUMINATED CONTROL PANEL WITH METAL KNOBS

Metal knobs have blue progressive illumination that adjusts to indicate whether the burner is on regular or ExtraLow settings.

★ MASTERPIECE® DESIGN

With chiseled edges and a trapezoid control panel, these cooktops were designed to coordinate perfectly with the entire Masterpiece® line of appliances.

★ STAR-K CERTIFIED

Thermador Gas Cooktops are Star-K certified making it possible to use them on the Sabbath or the Holidays.



★ THERMADOR® EXCLUSIVE



SGSL365KS
36-INCH GAS COOKTOP
MASTERPIECE® SERIES



GENERAL PROPERTIES

Controls	Metal Knobs
Sealed Burners	Yes
Grate Material	Cast Iron

BURNER PERFORMANCE

Total BTU Load (NG / LP)	60,200 / 45,200 BTU
Power of Front Left Burner (NG / LP)	9,100 / 6,000 BTU
Power of Back Left Burner (NG / LP)	12,000 / 9,100 BTU
Power of Center Burner (NG / LP)	18,000 / 15,000 BTU
Power of Back Right Burner (NG / LP)	9,100 / 6,000 BTU
Power of Front Right Burner (NG / LP)	12,000 / 9,100 BTU

TECHNICAL DETAILS

Watts (W)	1,800 W
Circuit Breaker (A)	15 A
Volts (V)	120 V
Frequency (Hz)	60 Hz
Plug Type	3 prong
Power Cord Length (in)	60"
Energy Source	Gas
Convertible To LP (Kit Required)	Yes

DIMENSIONS & WEIGHT

Overall Appliance Dimensions (HxWxD) (in)	5 3/16" +3 13/16" x 37" x 21 1/4"
Required Cutout Size (HxWxD) (in)	3 13/16" x 34 15/16" x 19 1/8"
Minimum Distance From Counter Front (in)	1 7/8"
Minimum Distance From Rear Wall (in)	3"
Net Weight (lbs)	49 lbs

WARRANTY

Limited Warranty, Entire Appliance, Parts and Labor	2 Year
---	--------

FEATURES & BENEFITS

- ★ - Patented and exclusive Star® Burner provides superior performance
- ★ - Progressive illuminated control panel with metal knobs
 - Powerful 18,000 BTU center-mounted burner
 - Continuous grates allow pots and pans to glide smoothly across the cooktop
 - Automatic electronic re-ignition

ACCESSORIES (OPTIONAL)



SWOKRINGF
Wok Ring

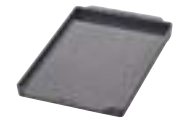

SGRIDDLEF
Griddle



SNLPKITF
LP Conversion Kit

SGSX365FS
36-INCH GAS COOKTOP
MASTERPIECE® SERIES



GENERAL PROPERTIES

Controls	Metal Knobs
Sealed Burners	Yes
Grate Material	Cast Iron

BURNER PERFORMANCE

Total BTU Load (NG / LP)	60,200 / 45,200 BTU
Power of Front Left Burner (NG / LP)	9,100 / 6,000 BTU
Power of Back Left Burner (NG / LP)	12,000 / 9,100 BTU
Power of Center Burner (NG / LP)	18,000 / 15,000 BTU
Power of Back Right Burner (NG / LP)	9,100 / 6,000 BTU
Power of Front Right Burner (NG / LP)	12,000 / 9,100 BTU

TECHNICAL DETAILS

Watts (W)	1,800 W
Circuit Breaker (A)	15 A
Volts (V)	120 V
Frequency (Hz)	60 Hz
Plug Type	3 prong
Power Cord Length (in)	60"
Energy Source	Gas
Convertible To LP (Kit Required)	Yes

DIMENSIONS & WEIGHT

Overall Appliance Dimensions (HxWxD) (in)	5 3/16" +3 13/16" x 37" x 21 1/4"
Required Cutout Size (HxWxD) (in)	3 13/16" x 34 15/16" x 19 1/8"
Minimum Distance From Counter Front (in)	1 7/8"
Minimum Distance From Rear Wall (in)	3"
Net Weight (lbs)	41 lbs

WARRANTY

Limited Warranty, Entire Appliance, Parts and Labor	2 Year
---	--------

FEATURES & BENEFITS

- ★ - Patented and exclusive Star® Burner provides superior performance
- ★ - 200 BTU ExtraLow® burners for perfect simmering
- ★ - Progressive illuminated control panel with metal knobs
 - Powerful 18,000 BTU center-mounted burner
 - Single point ignition system with automatic electronic re-ignition

ACCESSORIES (OPTIONAL)



SWOKRINGF
Wok Ring

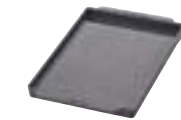

SGRIDDLEF
Griddle



SNLPKITF
LP Conversion Kit

SGS365FS
36-INCH GAS COOKTOP
MASTERPIECE® SERIES



GENERAL PROPERTIES

Controls	Metal Knobs
Sealed Burners	Yes
Grate Material	Cast Iron

BURNER PERFORMANCE

Total BTU Load (NG / LP)	58,200 / 45,200 BTU
Power of Front Left Burner (NG / LP)	9,100 / 6,000 BTU
Power of Back Left Burner (NG / LP)	12,000 / 9,100 BTU
Power of Center Burner (NG / LP)	16,000 / 15,000 BTU
Power of Back Right Burner (NG / LP)	9,100 / 6,000 BTU
Power of Front Right Burner (NG / LP)	12,000 / 9,100 BTU

TECHNICAL DETAILS

Watts (W)	1,800 W
Circuit Breaker (A)	15 A
Volts (V)	120 V
Frequency (Hz)	60 Hz
Plug Type	3 prong
Power Cord Length (in)	60"
Energy Source	Gas
Convertible To LP (Kit Required)	Yes

DIMENSIONS & WEIGHT

Overall Appliance Dimensions (HxWxD) (in)	5 3/16" +3 13/16" x 37" x 21 1/4"
Required Cutout Size (HxWxD) (in)	3 13/16" x 34 15/16" x 19 1/8"
Minimum Distance From Counter Front (in)	1 7/8"
Minimum Distance From Rear Wall (in)	3"
Net Weight (lbs)	39 lbs

WARRANTY

Limited Warranty, Entire Appliance, Parts and Labor	2 Year
---	--------

FEATURES & BENEFITS

- ★ - Patented and exclusive Star® Burner provides superior performance
- Powerful 16,000 BTU center burner
- Continuous grates allow pots and pans to glide smoothly across the cooktop
- Automatic electronic re-ignition
- Metal knobs feature a safety "push to turn" system

ACCESSORIES (OPTIONAL)



SWOKRINGF
Wok Ring

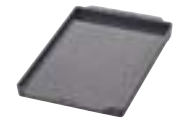

SGRIDDLEF
Griddle



SNLPKITF
LP Conversion Kit

SGSX305FS
30-INCH GAS COOKTOP
MASTERPIECE® SERIES



GENERAL PROPERTIES

Controls	Metal Knobs
Sealed Burners	Yes
Grate Material	Cast Iron

BURNER PERFORMANCE

Total BTU Load (NG / LP)	52,000 / 45,200 BTU
Power of Front Left Burner (NG / LP)	8,000 / 6,000 BTU
Power of Back Left Burner (NG / LP)	10,000 / 9,100 BTU
Power of Center Burner (NG / LP)	16,000 / 15,000 BTU
Power of Back Right Burner (NG / LP)	8,000 / 6,000 BTU
Power of Front Right Burner (NG / LP)	10,000 / 9,100 BTU

TECHNICAL DETAILS

Watts (W)	1,800 W
Circuit Breaker (A)	15 A
Volts (V)	120 V
Frequency (Hz)	60 Hz
Plug Type	3 prong
Power Cord Length (in)	60"
Energy Source	Gas
Convertible To LP (Kit Required)	Yes

DIMENSIONS & WEIGHT

Overall Appliance Dimensions (HxWxD) (in)	5 3/16" +3 13/16" x 31" x 21 1/4"
Required Cutout Size (HxWxD) (in)	3 13/16" x 28 15/16" x 19 1/8"
Minimum Distance From Counter Front (in)	1 7/8"
Minimum Distance From Rear Wall (in)	3"
Net Weight (lbs)	38 lbs

WARRANTY

Limited Warranty, Entire Appliance, Parts and Labor	2 Year
---	--------

FEATURES & BENEFITS

- ★ - Most powerful 30" cooktop in the luxury segment (amongst leading manufacturers) with an overall output of 52,000 BTU
- ★ - Patented and exclusive Star® Burner provides superior performance
- ★ - Exclusive 200 BTU ExtraLow® burners for perfect simmering
- ★ - Progressive illuminated control panel with metal knobs
- 30" 5 burner gas cooktop provides functionality of a 36" cooktop in a compact kitchen environment

ACCESSORIES (OPTIONAL)



SWOKRINGF
Wok Ring

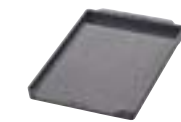

SGRIDDLEF
Griddle



SNLPKITF
LP Conversion Kit

SGS305FS
30-INCH GAS COOKTOP
MASTERPIECE® SERIES



FEATURES & BENEFITS

- ★ - Most powerful 30" cooktop in the luxury segment (amongst leading manufacturers) with an overall output of 52,000 BTU
- ★ - Patented and exclusive Star® Burner provides superior performance
 - 30" 5 burner gas cooktop provides functionality of a 36" cooktop in a compact kitchen environment
 - Powerful 16,000 BTU center burner
 - Continuous grates allow pots and pans to glide smoothly across the cooktop

ACCESSORIES (OPTIONAL)



SWOKRINGF
Wok Ring

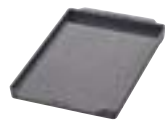

SGRIDDLEF
Griddle



SNLPKITF
LP Conversion Kit

GENERAL PROPERTIES

Controls	Metal Knobs
Sealed Burners	Yes
Grate Material	Cast Iron

BURNER PERFORMANCE

Total BTU Load (NG / LP)	52,000 / 45,200 BTU
Power of Front Left Burner (NG / LP)	8,000 / 6,000 BTU
Power of Back Left Burner (NG / LP)	10,000 / 9,100 BTU
Power of Center Burner (NG / LP)	16,000 / 15,000 BTU
Power of Back Right Burner (NG / LP)	8,000 / 6,000 BTU
Power of Front Right Burner (NG / LP)	10,000 / 9,100 BTU

TECHNICAL DETAILS

Watts (W)	1,800 W
Circuit Breaker (A)	15 A
Volts (V)	120 V
Frequency (Hz)	60 Hz
Plug Type	3 prong
Power Cord Length (in)	60"
Energy Source	Gas
Convertible To LP (Kit Required)	Yes

DIMENSIONS & WEIGHT

Overall Appliance Dimensions (HxWxD) (in)	5 3/16" x 31" x 21 1/4"
Required Cutout Size (HxWxD) (in)	3 13/16" x 28 15/16" x 19 1/8"
Minimum Distance From Counter Front (in)	1 7/8"
Minimum Distance From Rear Wall (in)	3"
Net Weight (lbs)	36 lbs

WARRANTY

Limited Warranty, Entire Appliance, Parts and Labor	2 Year
---	--------

SGS304FS
30-INCH GAS COOKTOP
MASTERPIECE® SERIES



FEATURES & BENEFITS

- ★ - Patented and exclusive Star® Burner provides superior performance
- ★ - Unique shape of the Star® Burner offers wider heat coverage resulting in smaller cold spots
 - Powerful 16,000 BTU Burner
 - Continuous grates allow pots and pans to glide smoothly across the cooktop
 - Automatic electronic re-ignition

ACCESSORIES (OPTIONAL)



SWOKRINGF
Wok Ring



SNLPKITF
LP Conversion Kit

GENERAL PROPERTIES

Controls	Metal Knobs
Sealed Burners	Yes
Grate Material	Cast Iron

BURNER PERFORMANCE

Total BTU Load (NG / LP)	44,000 / 39,200 BTU
Power of Front Left Burner (NG / LP)	10,000 / 9,100 BTU
Power of Back Left Burner (NG / LP)	10,000 / 9,100 BTU
Power of Center Burner (NG / LP)	N/A
Power of Back Right Burner (NG / LP)	8,000 / 6,000 BTU
Power of Front Right Burner (NG / LP)	16,000 / 15,000 BTU

TECHNICAL DETAILS

Watts (W)	1,800 W
Circuit Breaker (A)	15 A
Volts (V)	120 V
Frequency (Hz)	60 Hz
Plug Type	3 prong
Power Cord Length (in)	60"
Energy Source	Gas
Convertible To LP (Kit Required)	Yes

DIMENSIONS & WEIGHT

Overall Appliance Dimensions (HxWxD) (in)	5 3/16" x 31" x 21 1/4"
Required Cutout Size (HxWxD) (in)	3 13/16" x 28 15/16" x 19 1/8"
Minimum Distance From Counter Front (in)	1 7/8"
Minimum Distance From Rear Wall (in)	3"
Net Weight (lbs)	37 lbs

WARRANTY

Limited Warranty, Entire Appliance, Parts and Labor	2 Year
---	--------

MODEL OPTIONS

There are two sizes of Thermador Masterpiece® Gas Cooktops to choose from—30-inch and 36-inch. 30-inch models are available with four Star® Burners or five Star Burners. 36-inch models feature five Star Burners. Every model is LP convertible by ordering SNLPKITF. Be sure to reference the correct model information in this design guide.

INSTALLATION CONSIDERATIONS

The information in this design guide provides key features, product dimensions, cutouts and installation specifications. Before installing a Thermador Masterpiece® Gas Cooktop, be sure to verify the cutout dimensions and electrical / gas connections. Also, always consult with the installation manual packed with the product for complete details before installing.

Thermador Masterpiece® Gas Cooktops may be installed above a Thermador Single Built-in Oven as long as there is no contact between the bottom of the cooktop and the top of the oven.

See below for approved cooktop over oven installation.

MODEL	APPROVED COOKTOP OVER THERMADOR OVEN INSTALLATION
SGSL365KS	•
SGSX365FS	•
SGS365FS	•
SGSX305FS	•
SGS305FS	•
SGS304FS	•

Cooktops that are not listed above, must be approved under local code and / or by the local authority having jurisdictions.

Thermador Masterpiece® Gas Cooktops may also be installed above a Thermador Warming Drawer to create a convenient cooking center. Refer to the warming drawer section for additional specifications. Solid surface countertops require a special cutout size and special installation. For example, heat reflective tape or rounded corners may be necessary. Contact the countertop manufacturer for instructions specific to your countertop.

VENTILATION REQUIREMENTS

We strongly recommend that a Thermador Ventilation Hood be installed with all Thermador Masterpiece® Gas Cooktops. The hood must be installed according to instructions furnished with the hood. Refer to the ventilation section or www.thermador.com for a complete selection of ventilation options, blowers, and accessories.

When installing the gas cooktop with a downdraft ventilation system, provide approximately a 10 square inch opening (65 cm²) in the toekick area or other cabinet area for adequate air inlet. Refer to the downdraft ventilation section for more details.

ELECTRICAL AND GAS SPECIFICATIONS

Be sure your appliance is properly installed and grounded by a qualified technician. Installation, electrical and gas connections, and grounding must comply with all applicable local codes. Thermador Masterpiece® Gas Cooktops are equipped with a 60-inch, 3-wire supply cord.

MODEL	REQUIRED CIRCUIT BREAKER
	120V, 60 Hz
SGSL365KS	15 A
SGSX365FS	15 A
SGS365FS	15 A
SGSX305FS	15 A
SGS305FS	15 A
SGS304FS	15 A

IMPORTANT: It is required that the cooktop be installed on a grounded, non-GFCI branch circuit.

Thermador Masterpiece® Gas Cooktops are shipped by the factory to operate on natural gas. They must be converted for use with propane. Verify the type of gas being used at the installation site matches the type of gas used by the appliance. If the location / job site requires conversion from natural gas to propane (LP), order SNLPKITF. Field conversion must be done by qualified service personnel only. Please refer to the LP Conversion Instructions for further information.

SUPPLY PRESSURE REQUIREMENTS:

Natural Gas – 7 inches water column (14.9 Millibars) minimum.

LP (Propane Gas) – 11 inches water column (27.4 Millibars) minimum.

NOTE: The propane gas tank must be equipped with its own high pressure regulator in addition to the pressure regulator supplied with this unit.

ELECTRICAL AND GAS LOCATIONS

The opening for the gas connection and electrical cord is located at the right rear of rough-in box as shown to the left.

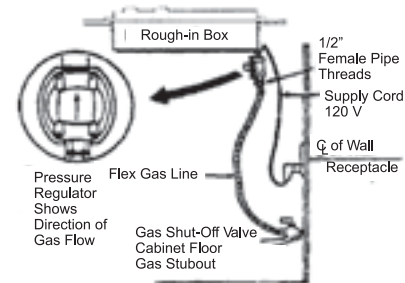
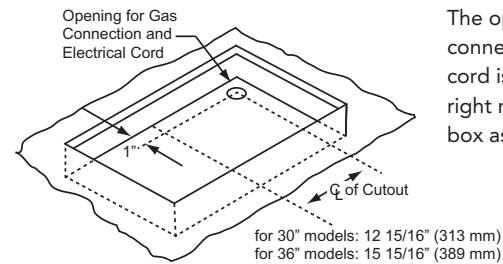

Plan the installation so that the power connection is accessible from the front of the cabinet. Install a manual gas shut-off valve near the appliance. It must be easily accessible in an emergency.

SGS365FS, SGSX365FS, SGSL365KS
36-INCH COOKTOP AND CUTOUT DIMENSIONS

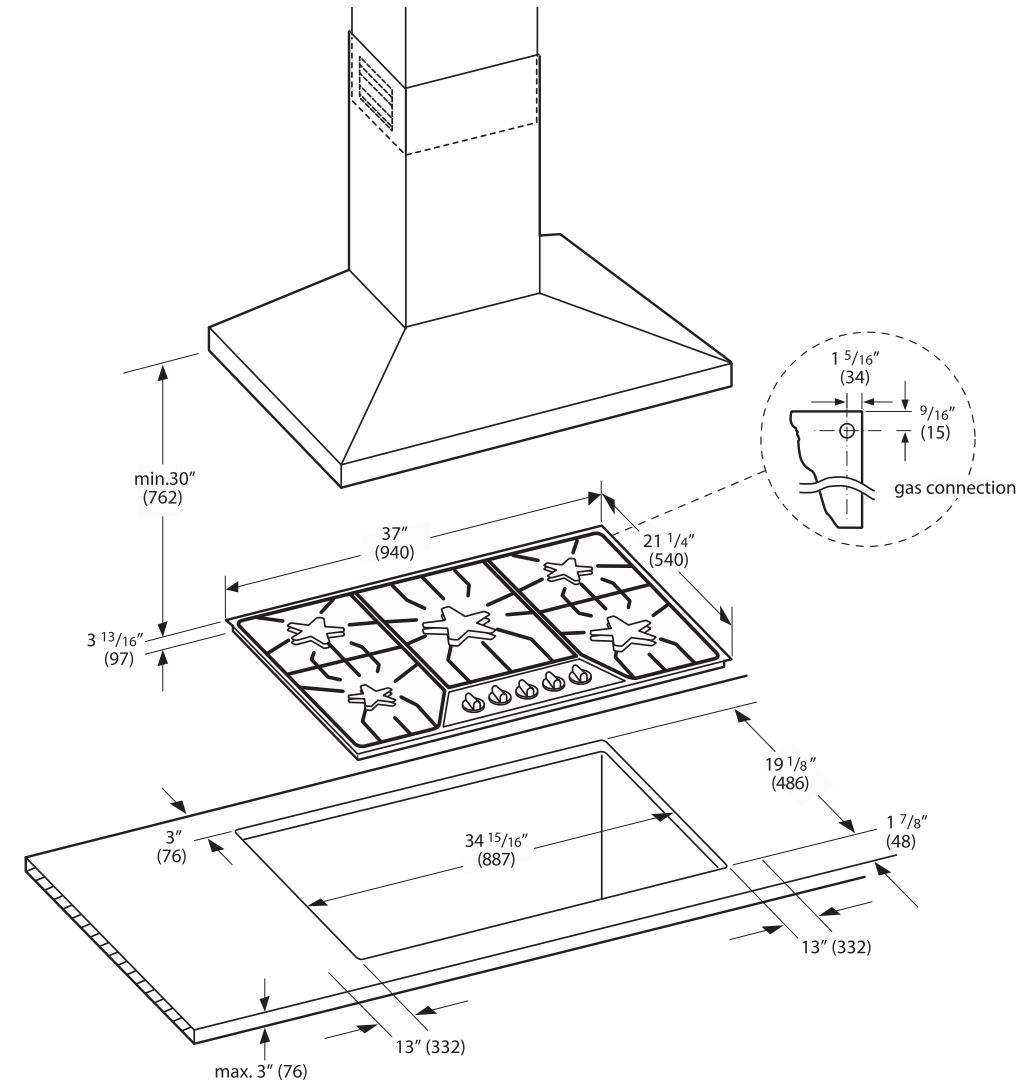

GAS COOKTOPS INSTALLATION

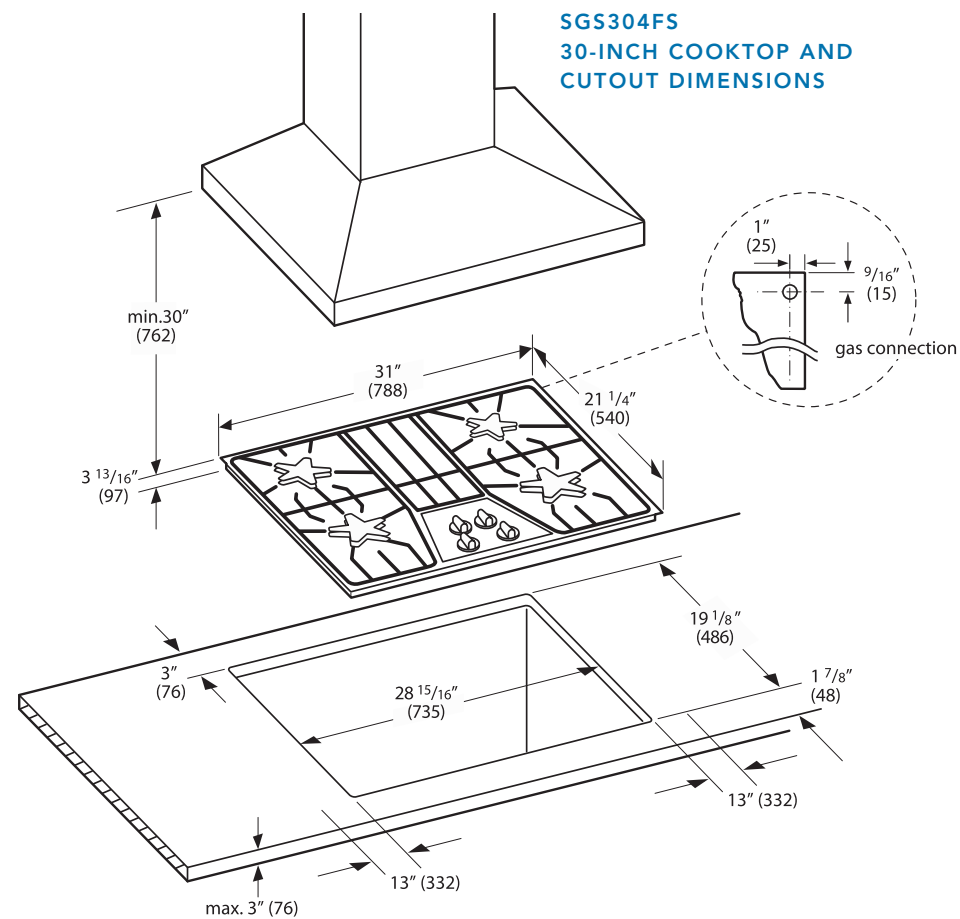
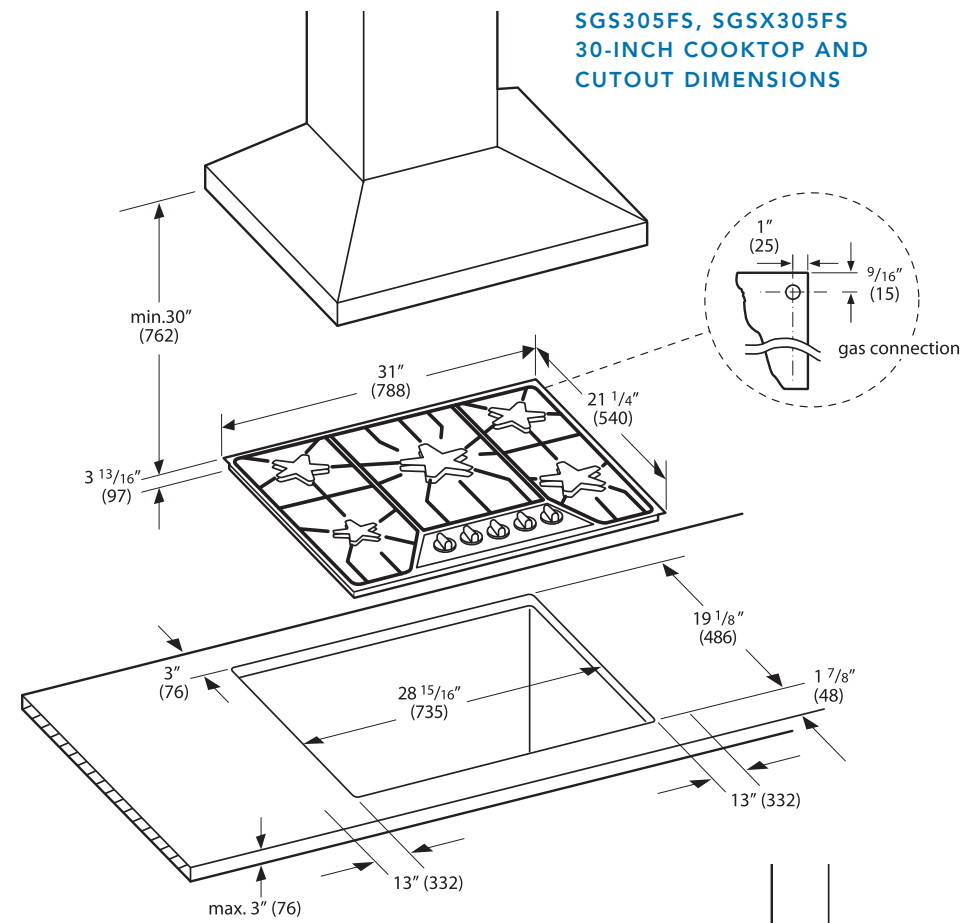

GAS COOKTOPS INSTALLATION

30-INCH & 36-INCH GAS COOKTOP CABINET REQUIREMENTS

Dimension requirements are for combustible surfaces. When the surface is protected by a material listed by UL as a Floor Protector and Wall Shield covered with not less than No. 28 MSG sheet metal 0.015 inch (0.38 mm) stainless steel, 0.024 inch (0.6 mm) aluminum or copper, it is considered noncombustible and some dimensions may be reduced. For a noncombustible surface over the cooktop, the minimum clearance is 24" (61 cm) rather than 30" (76 cm).

WARNING: To reduce the risk of ignition of nearby combustible materials, install the countertop with a minimum distance of 13" (33 cm) from side walls and 3" (8 cm) from back wall.

NOTE: All measurements given have to be precisely followed. If nonstandard cabinets are used, make sure they are installed with minimum dimensions shown.

Plan the installation of the unit so that the power cord, gas shut-off valve and gas pressure regulator are accessible from the front of cabinet.

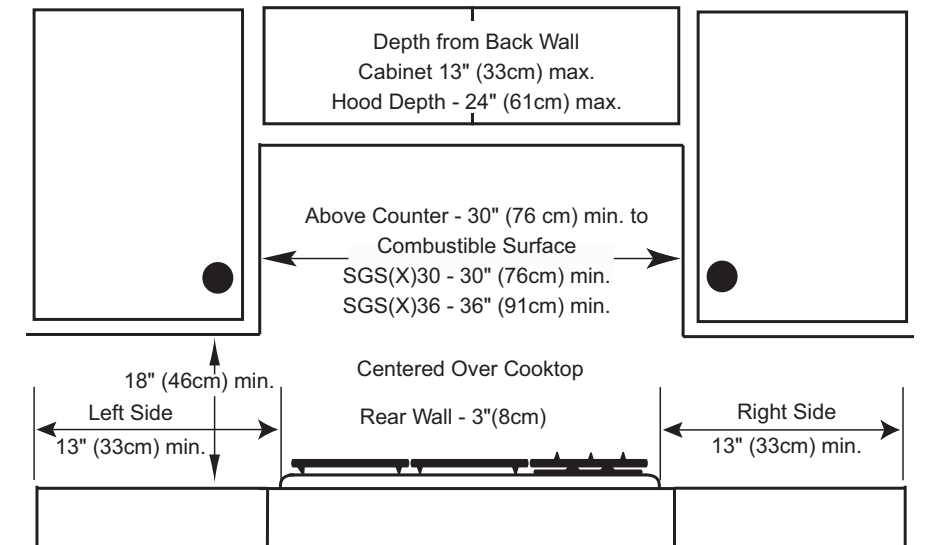

30-INCH & 36-INCH GAS COOKTOP INSTALLATION ABOVE A THERMADOR BUILT-IN OVEN

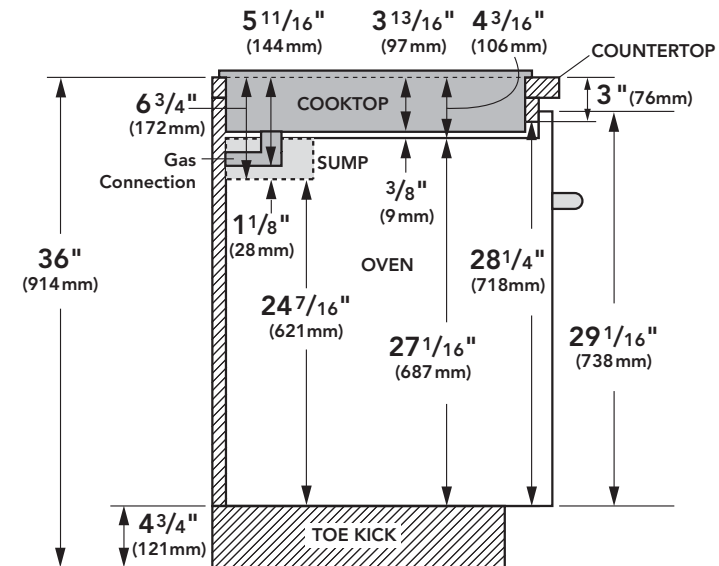

Note: Dimensions based on standard countertop height (36" with 4 3/4" toe kick including base plate).

The built-in oven can be installed below the gas cooktop as long as there is no contact between the bottom of the cooktop and the top of the oven.

Sump applies to 30-inch Wall Ovens only.



Thermador ★

ELECTRIC COOKTOPS

MASTERPIECE® SERIES

The all-new Thermador Electric Cooktop collection introduces features and designs that secure its place at the top of the luxury cooking market. With incredibly powerful elements, as well as a dual-zone heat bridge, redesigned control panels, updated finishes and a variety of layouts to choose from, Thermador Electric Cooktops beat the competition—and allow you to truly personalize the way you cook.



Intelligent Cooking
FOR DEMANDING CHEFS

CookSmart® technology allows you to simmer without scorching, boil without boiling over and deep fry without burning. With preset CookSmart temperature modes, meals practically prepare themselves.

★ **COOKSMART®**

Get consistent results for even the most complex recipes. CookSmart includes 4 preset frying levels so each dish as exceptional as the last.

★ **THERMADOR® EXCLUSIVE**



Electric Cooktops
FEATURE HIGHLIGHTS

★ **HEAT BRIDGE ELEMENT**

A Thermador® Exclusive, this unique dual zone bridge element connects two round elements, enabling use of large oval or rectangular cookware to provide even heating with no cold spots.

★ **POWERBOOST®**

Designed to bring food to the desired temperature in the shortest amount of time, PowerBoost delivers maximum powerful output.

★ **TRIPLE ELEMENT**

Revel in complete flexibility. Thermador electric cooktops feature three differently sized elements set in one location to adapt to the size of your cookware.



CET366TB
36-INCH ELECTRIC COOKTOP
MASTERPIECE® SERIES



FEATURES & BENEFITS

- ★ - CookSmart® – with 4 preset frying levels, a sensor controls the temperature of the pan taking the guesswork out of temperature selection
- ★ - Dual zone bridge element accommodates oblong cookware and multiple diameter sizes
 - Cook timer allows you to set a cook time for any element and turns off automatically once time has elapsed
 - Illuminated touch control panel offers intuitively simple selection of power levels and allows for easy cleaning
 - Full stainless steel frame surrounds the cooktop surface

ACCESSORIES (OPTIONAL)



CHEFSPAN08
10" Stainless Steel Pan

GENERAL PROPERTIES	
Controls	Touch Controls
ELEMENT PERFORMANCE	
Power of Front Left Heating Element	1,700 W
Power of Front Left Heating Element (In Boost)	3,000 W
Power of Back Left Heating Element	1,700 / 700 W
Power of Bridge Element	4,000 W
Power of Center Heating Element	3,080 / 2,200 / 1,050 W
Power of Back Right Heating Element	1,200 W
Power of Front Right Heating Element	2,100 / 1,200 W
ELEMENT SIZE	
Dimension of Front Left Heating Element	7"
Dimension of Back Left Heating Element	7", 5"
Dimension of Center Heating Element	11", 8", 6"
Dimension of Back Right Heating Element	6"
Dimension of Front Right Heating Element	8", 6"
TECHNICAL DETAILS	
Watts (W)	10,520 W
Circuit Breaker (A)	50 / 40 A
Volts (V)	240 / 208 V
Frequency (Hz)	60 Hz
Plug Type	No Plug
Conduit	38" Flexible 3-Wire
Energy Source	Electric
DIMENSIONS & WEIGHT	
Overall Appliance Dimensions (HxWxD) (in)	7/16"+3 15/16" x 37" x 21 1/4"
Required Cutout Size (HxWxD) (in)	3 15/16" x 34 3/4" x 19 7/8"
Minimum Distance From Counter Front (in)	2 1/4"
Minimum Distance From Rear Wall (in)	2 3/4"
Net Weight (lbs)	34 lbs
WARRANTY	
Limited Warranty, Entire Appliance, Parts and Labor	2 Year

CEM365NS
36-INCH ELECTRIC COOKTOP
MASTERPIECE® SERIES



FEATURES & BENEFITS

- Dual element offers the capability to use multiple pan sizes
- 2-level digital control panel indicates when elements are still hot
- Full stainless steel frame
- Trapezoid design control panel
- Heavy-duty, high quality metal knobs

GENERAL PROPERTIES	
Controls	Metal Knobs
ELEMENT PERFORMANCE	
Power of Front Left Heating Element	2,200 / 750 W
Power of Back Left Heating Element	1,200 W
Power of Center Heating Element	3,100 / 1,300 W
Power of Back Right Heating Element	1,800 W
Power of Front Right Heating Element	1,800 W
ELEMENT SIZE	
Dimension of Front Left Heating Element	8", 5"
Dimension of Back Left Heating Element	6"
Dimension of Center Heating Element	9", 6"
Dimension of Back Right Heating Element	7"
Dimension of Front Right Heating Element	7"
TECHNICAL DETAILS	
Watts (W)	10,100 W
Circuit Breaker (A)	50 / 40 A
Volts (V)	240 / 208 V
Frequency (Hz)	60 Hz
Plug Type	No Plug
Conduit	38" Flexible 3-Wire
Energy Source	Electric
DIMENSIONS & WEIGHT	
Overall Appliance Dimensions (HxWxD) (in)	7/16"+3 15/16" x 37" x 21 1/4"
Required Cutout Size (HxWxD) (in)	3 15/16" x 34 3/4" x 19 7/8"
Minimum Distance From Counter Front (in)	2 1/4"
Minimum Distance From Rear Wall (in)	2 3/4"
Net Weight (lbs)	29 lbs
WARRANTY	
Limited Warranty, Entire Appliance, Parts and Labor	2 Year

CET305TB
30-INCH ELECTRIC COOKTOP
MASTERPIECE® SERIES



FEATURES & BENEFITS

- ★ - CookSmart® – with 4 preset frying levels, a sensor controls the temperature of the pan, taking the guesswork out of temperature selection
- ★ - Dual zone bridge element accommodates oblong cookware and multiple diameter sizes
 - Cook timer allows you to set a cook time for any element and turns off automatically once time has elapsed
 - Triple zone center element allows you to match element size to various sized cookware
 - Illuminated touch control panel offers intuitively simple selection of power levels and allows for easy cleaning

ACCESSORIES (OPTIONAL)



CHEFSPAN08
10" Stainless Steel Pan



GENERAL PROPERTIES	
Controls	Touch Controls
ELEMENT PERFORMANCE	
Power of Front Left Heating Element	1,700 W
Power of Back Left Heating Element	1,700 / 700 W
Power of Bridge Element	4,000 W
Power of Center Heating Element	3,080 / 2,200 / 1,050 W
Power of Back Right Heating Element	N/A
Power of Front Right Heating Element	1,200 W
ELEMENT SIZE	
Dimension of Front Left Heating Element	7"
Dimension of Back Left Heating Element	7", 5"
Dimension of Center Heating Element	11", 8", 6"
Dimension of Back Right Heating Element	N/A
Dimension of Front Right Heating Element	6"
TECHNICAL DETAILS	
Watts (W)	7,800 W
Circuit Breaker (A)	40 / 30 A
Volts (V)	240 / 208 V
Frequency (Hz)	60 Hz
Plug Type	No Plug
Conduit	3/8" Flexible 3-Wire
Energy Source	Electric
DIMENSIONS & WEIGHT	
Overall Appliance Dimensions (HxWxD) (in)	7/16"+3 15/16" x 31" x 21 1/4"
Required Cutout Size (HxWxD) (in)	3 15/16" x 28 3/4" x 19 7/8"
Minimum Distance From Counter Front (in)	2 1/4"
Minimum Distance From Rear Wall (in)	2 3/4"
Net Weight (lbs)	26 lbs
WARRANTY	
Limited Warranty, Entire Appliance, Parts and Labor	2 Year

CEM304NS
30-INCH ELECTRIC COOKTOP
MASTERPIECE® SERIES



FEATURES & BENEFITS

- Dual element offers the capability to use multiple pan sizes
- Cooktop indicates when elements are still hot
- Full stainless steel frame
- Chiseled, angular design coordinates with the suite of Thermador Masterpiece® Collection appliances
- Heavy-duty, high quality metal knobs



GENERAL PROPERTIES	
Controls	Metal Knobs
ELEMENT PERFORMANCE	
Power of Front Left Heating Element	1,200 W
Power of Back Left Heating Element	3,100 / 1,300 W
Power of Center Heating Element	N/A
Power of Back Right Heating Element	2,200 / 750 W
Power of Front Right Heating Element	1,800 W
ELEMENT SIZE	
Dimension of Front Left Heating Element	6"
Dimension of Back Left Heating Element	9", 6"
Dimension of Center Heating Element	N/A
Dimension of Back Right Heating Element	8", 5"
Dimension of Front Right Heating Element	7"
TECHNICAL DETAILS	
Watts (W)	8,300 W
Circuit Breaker (A)	40 / 30 A
Volts (V)	240 / 208 V
Frequency (Hz)	60 Hz
Plug Type	No Plug
Conduit	3/8" Flexible 3-Wire
Energy Source	Electric
DIMENSIONS & WEIGHT	
Overall Appliance Dimensions (HxWxD) (in)	7/16"+3 15/16" x 31" x 21 1/4"
Required Cutout Size (HxWxD) (in)	3 15/16" x 28 3/4" x 19 7/8"
Minimum Distance From Counter Front (in)	2 1/4"
Minimum Distance From Rear Wall (in)	2 3/4"
Net Weight (lbs)	26 lbs
WARRANTY	
Limited Warranty, Entire Appliance, Parts and Labor	2 Year

MODEL OPTIONS

There are two sizes of Masterpiece® Electric Cooktops to choose from—30-inch and 36-inch. Models are available with mechanical controls and touch controls in a variety of cooktop configurations to fit your client’s cooking style. Be sure to reference the correct model information in this design guide.

INSTALLATION CONSIDERATIONS

The information in this design guide provides key features, product dimensions, cutouts and installation specifications. Before installing a Thermador Masterpiece® Electric Cooktop, be sure to verify the cutout dimensions and electrical connections. Also, always consult with the installation manual packed with the product for complete details before installing.

Thermador Masterpiece® Electric Cooktops may be installed above a Thermador Single Built-in Oven as long as there is no contact between the bottom of the cooktop and the top of the oven. **See below for approved cooktop over oven installation.**

MODEL	APPROVED COOKTOP OVER THERMADOR OVEN INSTALLATION
CET366TB	•
CEM365NS	•
CET305TB	•
CEM304NS	•

Cooktops that are not listed above, must be approved under local code and / or by the local authority having jurisdictions.

Thermador Masterpiece® Electric Cooktops may also be installed above a Thermador Warming Drawer to create a convenient cooking center. Refer to the warming drawer section for additional specifications.

Solid surface countertops require a special cutout size and installation. For example, heat reflective tape or rounded corners may be necessary. Contact the countertop manufacturer for instructions specific to your countertop.

We strongly recommend the installation of a Thermador Ventilation System with all Masterpiece® Electric Cooktops. Refer to the ventilation section for specifications.

WARNING

To reduce the risk of ignition of nearby combustible materials, install the countertop with a minimum distance of 2" (51 mm) from both side walls and the back wall.

ELECTRICAL SPECIFICATIONS

Be sure your appliance is properly installed and grounded by a qualified technician. Installation, electrical connections and grounding must comply with all applicable local codes.

All Thermador Electric Cooktops are dual rated, designed to be connected to either 240 / 208V AC, 60 Hz, 3-wire, single-phase power supply.

Install a suitable conduit box (not furnished). An appropriately-sized, UL-listed conduit connector must be used to correctly attach the conduit to the junction box.

MODEL	REQUIRED CIRCUIT BREAKER
	240 / 208V, 3-Wire, 60 Hz
CET366TB	50 / 40 A
CEM365NS	50 / 40 A
CET305TB	40 / 30 A
CEM304NS	40 / 30 A

IMPORTANT: Local Codes may vary; installation, electrical connections and grounding must comply with all applicable local codes. If required by the National Electrical Code (or Canadian Electrical Code), this appliance must be installed on a separate branch circuit.

ELECTRICAL LOCATION

The junction box must be located within 3 feet (~900 mm) of the cooktop connection. It should be easily accessible for service purposes.

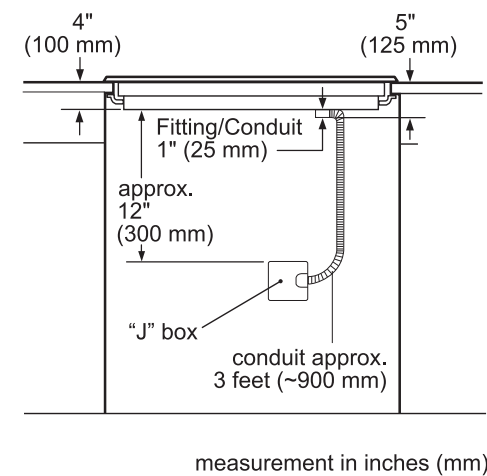

36-INCH CET366TB ELECTRIC COOKTOP AND CUTOUT DIMENSIONS

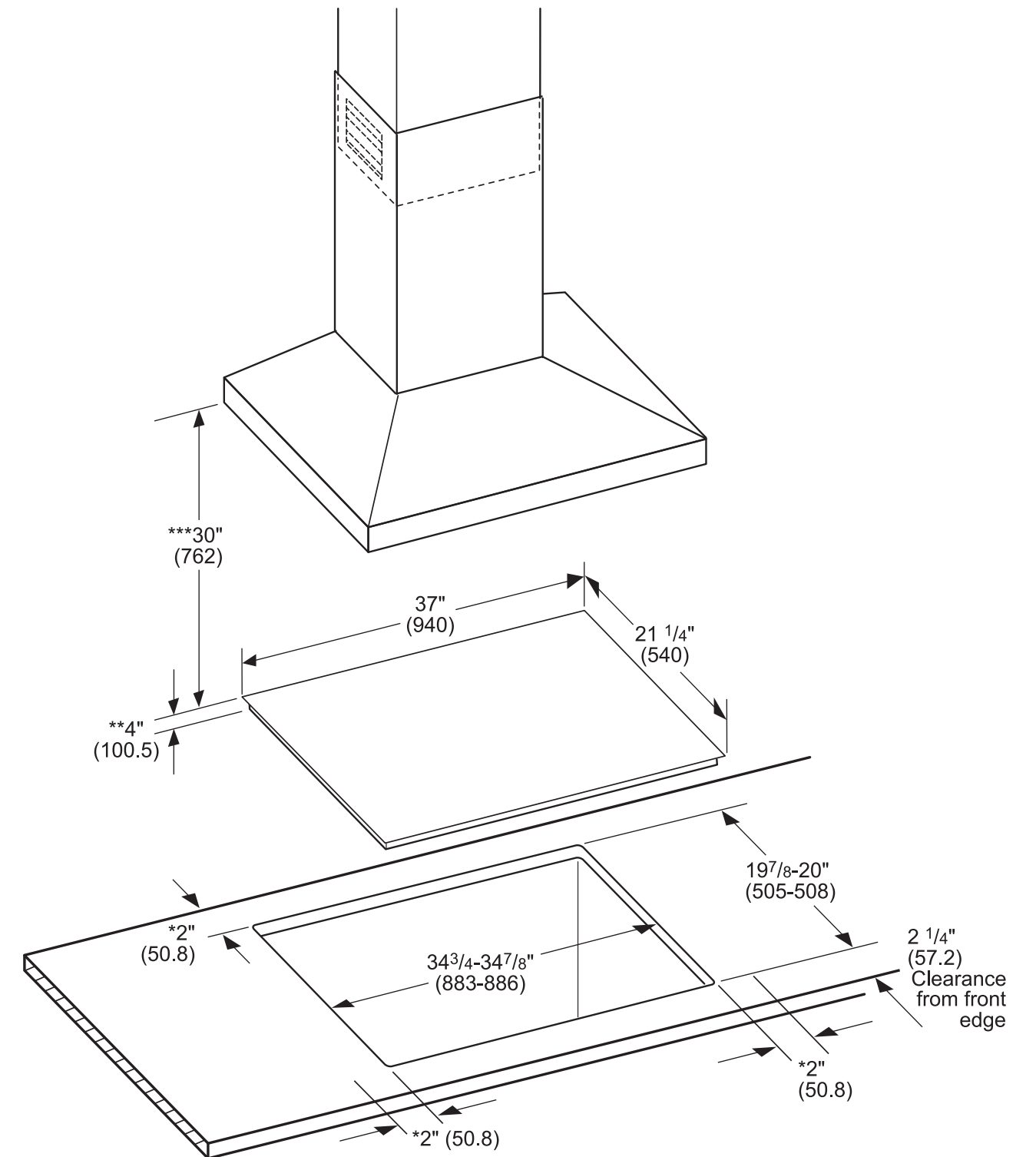

- * Minimum clearance from the cooktop cutout to the wall
- ** Maximum recessed depth
- *** Minimum clearance between the cooktop surface and lower edge of the exhaust hood.

ELECTRIC COOKTOPS

PLANNING INFORMATION

36-INCH CEM365NS ELECTRIC COOKTOP AND CUTOUT DIMENSIONS

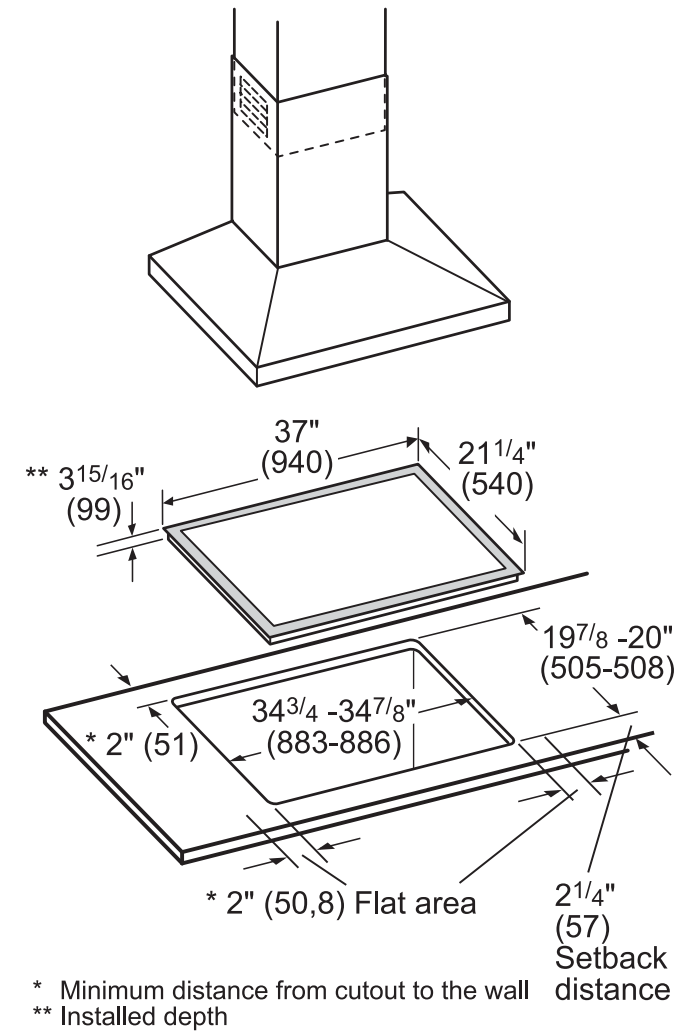

Measurements in inches (mm in brackets)

30-INCH CEM304NS ELECTRIC COOKTOP AND CUTOUT DIMENSIONS

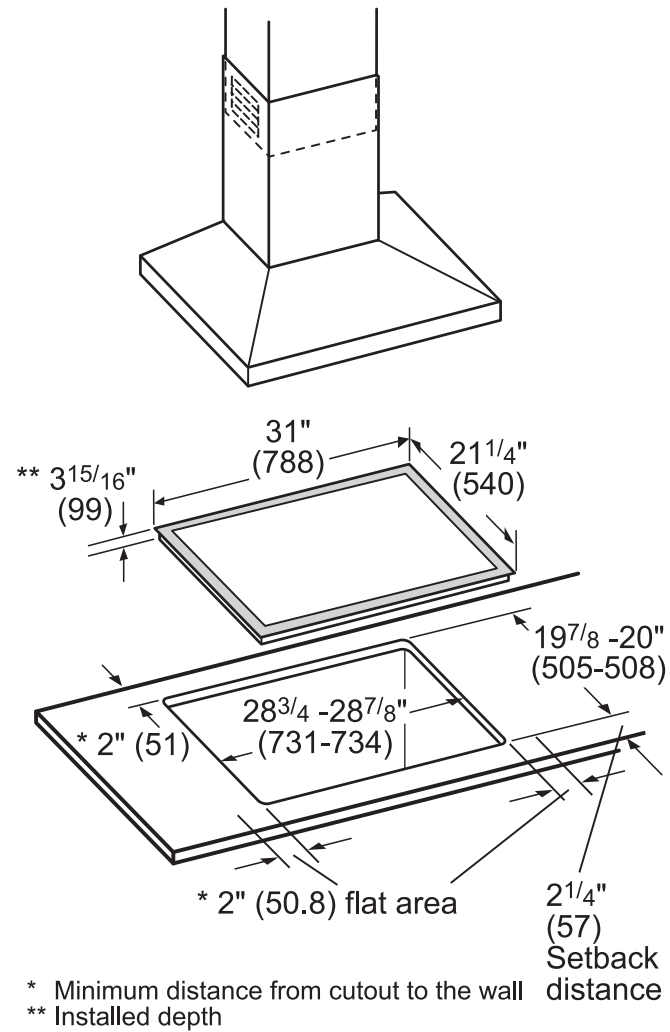

Measurements in inches (mm in brackets)

30-INCH & 36-INCH ELECTRIC COOKTOP COUNTERTOP REQUIREMENTS

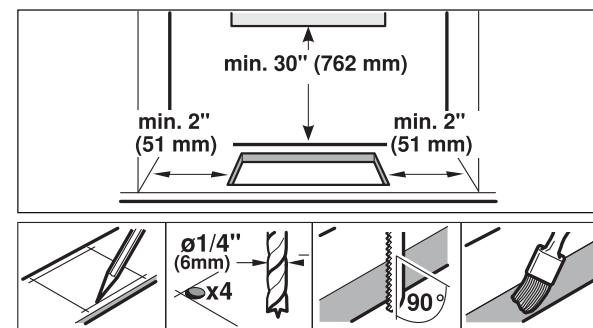

ELECTRIC COOKTOPS

PLANNING INFORMATION

30-INCH CET305TB ELECTRIC COOKTOP AND CUTOUT DIMENSIONS

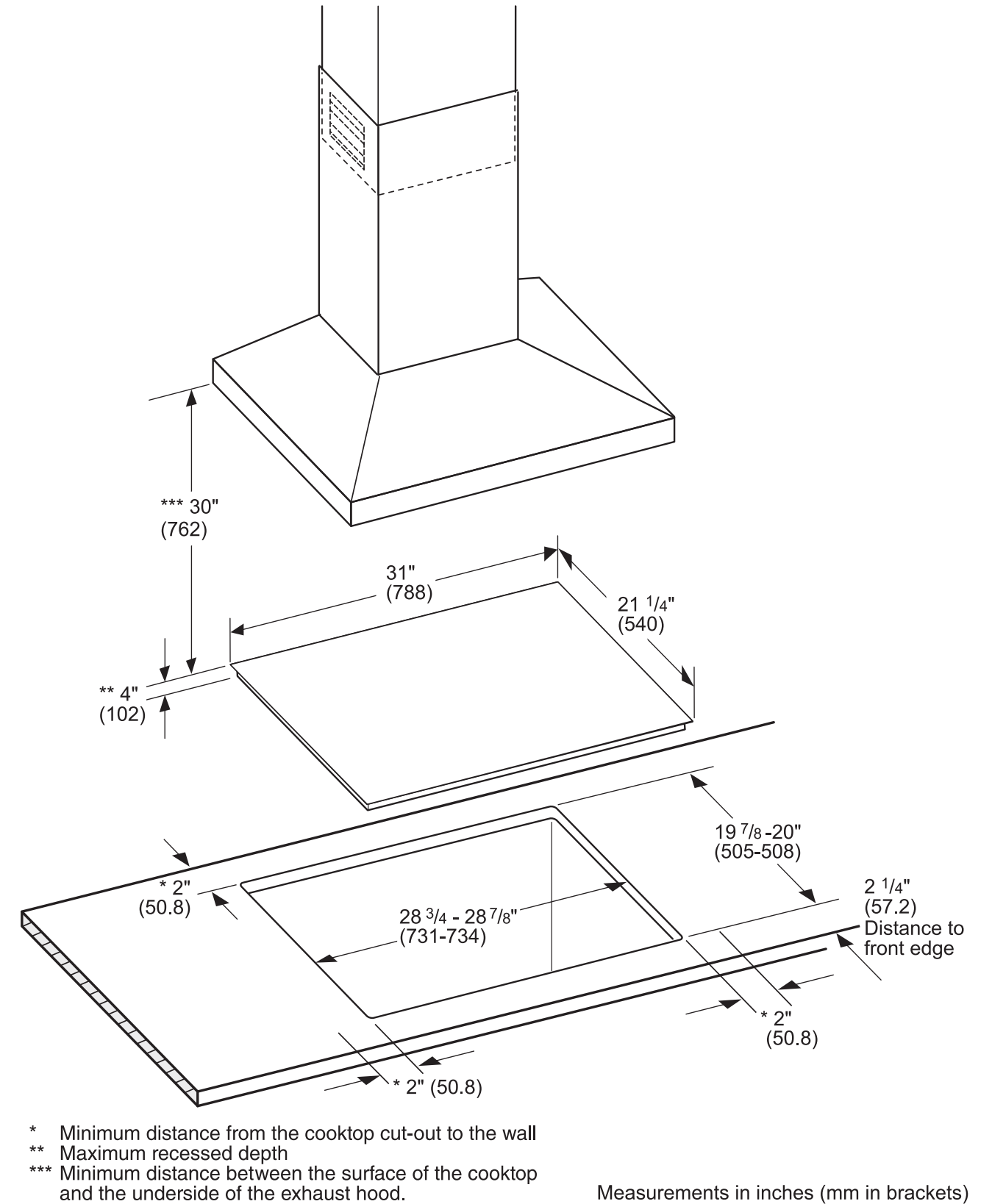

Measurements in inches (mm in brackets)

ELECTRIC COOKTOPS INSTALLATION

36-INCH CET366TB AND 30-INCH CET305TB ELECTRIC COOKTOP INSTALLATION ABOVE A THERMADOR BUILT-IN OVEN

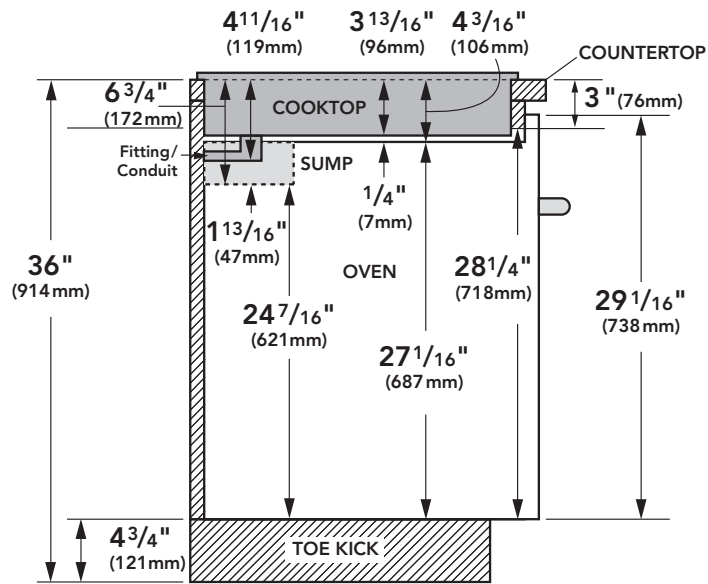

Note: Dimensions based on standard countertop height (36" with 4 3/4" toe kick including base plate).

The built-in oven can be installed below the electric cooktop as long as there is no contact between the bottom of the cooktop and the top of the oven.

Sump applies to 30-inch Wall Ovens only.

36-INCH CEM365NS AND 30-INCH CEM304NS ELECTRIC COOKTOP INSTALLATION ABOVE A THERMADOR BUILT-IN OVEN

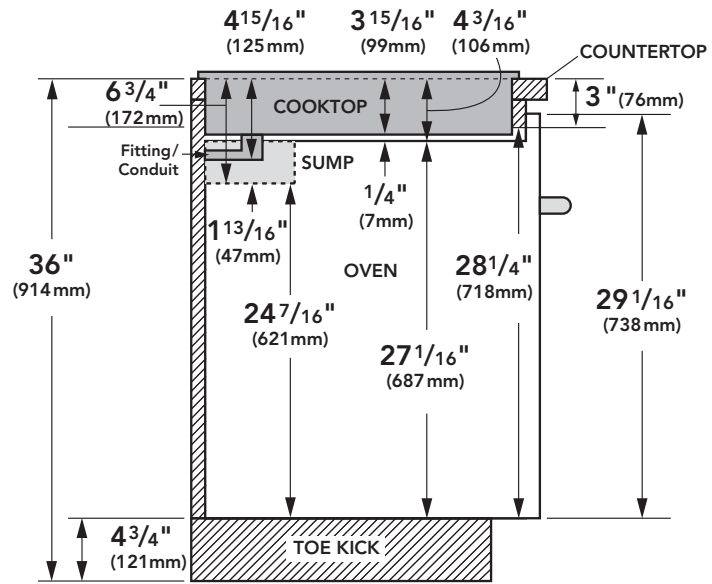

Note: Dimensions based on standard countertop height (36" with 4 3/4" toe kick including base plate).

The built-in oven can be installed below the electric cooktop as long as there is no contact between the bottom of the cooktop and the top of the oven.

Sump applies to 30-inch Wall Ovens only.

30-INCH & 36-INCH ELECTRIC COOKTOP CABINET REQUIREMENTS

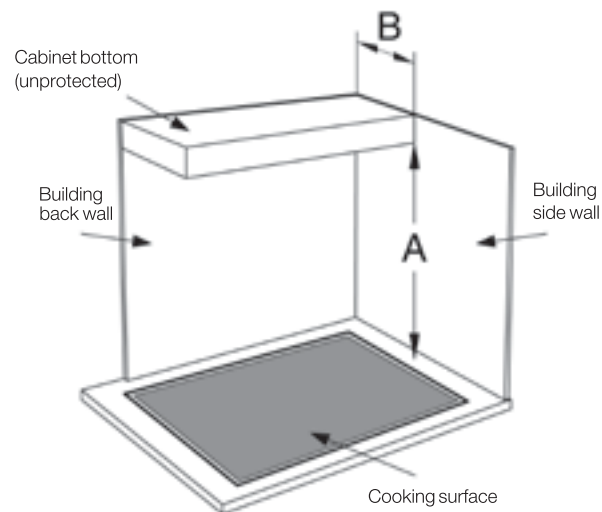

The distance from the top of the cooktop to the bottom of the cabinets above it must be $A = 30"$ (762 mm) minimum. This distance can be reduced to $A = 24"$ (610 mm) when the bottom of the wood or metal cabinet is protected by not less than 1/4" (6.35 mm) flame retardant millboard, covered by no. 28 steel sheet 0.015 (.4 mm) thick stainless steel, 0.024" (0.6 mm) aluminum, or 0.020" (0.5 mm) thick copper, at a minimum. Verify that the cabinets above the cooktop are a maximum of $B = 13"$ (330 mm) deep.



MODEL SHOWN: CET366TB ELECTRIC COOKTOP



Thermador 

VENTILATION

PROFESSIONAL & MASTERPIECE® SERIES

No need to worry about lingering odors or smoke with our elegant, powerful ventilation systems, featuring design accents that complement our Professional Series or our Masterpiece® Collection. These sophisticated ventilation systems remove smoke, grease and unhealthy airborne contaminants.

MODELS SHOWN: HPCB48NS 48-INCH PROFESSIONAL SERIES CHIMNEY WALL HOOD AND PRD486JDGU 48-INCH PROFESSIONAL SERIES PRO GRAND® DUAL-FUEL RANGE



WALL HOODS

- Create a bold, modern statement with a distinctive stainless steel wall hood
- Deep enclosure area for excellent capture
- Recirculation option at 600 CFM for Masterpiece® Collection



CHIMNEY WALL HOODS

- A chimney design offers a more contemporary feel
- Adjustable chimney heights suit a range of ceilings



CUSTOM INSERTS

- Create a seamless design that blends with your cabinetry
- Available options for all types of cooking surfaces
- User-friendly ventilation controls or remote control options
- Wall or island applications



ISLAND HOODS

- Island hoods float in the kitchen, creating a dramatic focal point
- Slim and sleek design that does not obstruct the views beyond your kitchen
- All stainless steel or stainless steel with elegant glass canopy design











DOWNDRAFTS

- The only hood that retreats out of sight for a sleek look with unobstructed kitchen views
- Over 13-inch intake
- Ideal in island applications
- 600 CFM recirculation kit option with integrated blower is available for difficult-to-duct situations

RANGE, RANGETOP & VENTILATION SELECTION GUIDE

PROFESSIONAL SERIES







✓ = PERFECT FIT ✓ = VIABLE OPTION

		 36-INCH PRO GRAND®	 48-INCH PRO GRAND	 60-INCH PRO GRAND
		27-INCH DEPTH		
 27-INCH DEPTH, 18-INCH TALL WALL HOODS	36-INCH PH36GS	✓		
	42-INCH PH42GS	✓		
	48-INCH PH48GS		✓	
	54-INCH PH54GS		✓	
	60-INCH PH60GS			✓
 24-INCH DEPTH, 18-INCH TALL WALL HOODS	30-INCH PH30HS			
	36-INCH PH36HS	✓		
	48-INCH PH48HS		✓	
 24-INCH DEPTH, 11-INCH TALL WALL HOODS	30-INCH HPWB30FS			
	36-INCH HPWB36FS	✓		
	48-INCH HPWB48FS		✓	
 24-INCH DEPTH CHIMNEY WALL HOODS	36-INCH HPCN36NS / HPCB36NS	✓		
	48-INCH HPCN48NS / HPCB48NS		✓	
 ISLAND HOODS	42-INCH HPIN42HS	✓		
	48-INCH HPIN48HS		✓	
 CUSTOM INSERTS	36-INCH VCIN36JP / VCIB36JP	✓		
	48-INCH VCIN48JP / VCIB48JP		✓	
	54-INCH VCIN54JP / VCIB54JP		✓	
	60-INCH VCIN60RP			✓

For optimal performance, the width of the hood should equal that of the cooktop or rangetop or exceed it by 3 inches on either side. Install these hoods only with Thermador Blowers.

RANGE, RANGETOP & VENTILATION SELECTION GUIDE

PROFESSIONAL SERIES

 30-INCH PRO HARMONY®	 36-INCH PRO HARMONY	 48-INCH PRO HARMONY	 30-INCH RANGETOP	 36-INCH RANGETOP	 48-INCH RANGETOP
24-INCH DEPTH			24-INCH DEPTH		
✓	✓		✓	✓	
	✓			✓	
		✓			✓
		✓			✓
✓			✓		
✓	✓		✓	✓	
		✓			✓
	✓			✓	
		✓			✓
✓	✓		✓	✓	
		✓			✓
		✓			✓











COOKTOP AND VENTILATION SELECTION GUIDE

MASTERPIECE® SERIES

COOKTOP AND VENTILATION SELECTION GUIDE

MASTERPIECE® SERIES

✓ = PERFECT FIT ✓ = VIABLE OPTION

		 30-INCH INDUCTION COOKTOP	 36-INCH INDUCTION COOKTOP	 30-INCH GAS COOKTOP	 36-INCH GAS COOKTOP
 WALL HOODS	30-INCH HMWN30FS	✓		✓	
	48-INCH HMWN48FS				✓
 WALL HOODS WITH BLOWER	30-INCH HMWB30FS	✓		✓	
	36-INCH HMWB36FS	✓	✓	✓	✓
 CHIMNEY WALL HOODS	36-INCH HMCN36FS	✓	✓	✓	✓
	42-INCH HMCN42FS		✓		✓
 CHIMNEY WALL HOODS WITH BLOWER	36-INCH HMCB36FS	✓	✓	✓	✓
	42-INCH HMCB42FS		✓		✓
 ISLAND HOODS WITH BLOWER	40-INCH HMIB40HS	✓	✓	✓	✓
	42-INCH HPIB42HS	✓	✓	✓	✓
	48-INCH HPIB48HS*		✓		✓
 DRAWER HOOD WITH BLOWER	36-INCH HDDW36FS	✓	✓	✓	✓
 CUSTOM INSERTS	30-INCH VCI230DS†	✓		✓	
	36-INCH VCI236DS†	✓	✓	✓	✓
	48-INCH VCI248DS†		✓		✓
 DOWNDRAFTS	30-INCH UCVM30FS	✓		✓	
	36-INCH UCVM36FS		✓		✓

 30-INCH ELECTRIC COOKTOP	 30-INCH SENSOR ELECTRIC COOKTOP	 36-INCH ELECTRIC COOKTOP	 36-INCH SENSOR ELECTRIC COOKTOP
✓	✓		
		✓	✓
✓	✓		
✓	✓	✓	✓
✓	✓		
		✓	✓
✓	✓	✓	✓
✓	✓		
		✓	✓
✓	✓		
✓	✓	✓	✓
✓	✓		
		✓	✓
✓	✓		
		✓	✓

For optimal performance, the width of the hood should equal that of the cooktop or rangetop or exceed it by 3 inches on either side. Install these hoods only with Thermador Blowers.

*Compatible with cooktops of widths up to 42-inch †Also compatible with Pro Grand Ranges, Pro Harmony Ranges and Professional Rangetops.

INSTALLATION CONSIDERATIONS

HOOD WIDTH

The hood width should be no less than the width of the cooking surface. Where space is not restricted, a wider hood can be used to increase your capture area.

DISTANCE FROM COOKING SURFACE

Proper mounting height is very important. If a hood is mounted too low, it may be difficult to cook and be unsafe. If a hood is mounted too high, performance may be compromised. For optimal performance, the distance from the cooking surface to the bottom of the hood should be a minimum of 30", unless otherwise noted. Please refer to the installation manual for each hood and cooktop / range model for proper hood mounting heights.

AVAILABLE CEILING HEIGHT

The standard ceiling height can vary from region to region and in homes built in different eras. Ceiling heights, even in the same room, can sometimes vary by as much as several inches. Kitchen ceiling heights can vary between 7'6" (or 90") to over 10' (or 120").

Before selecting a Thermador Hood, check the available installation space and any extra space that may remain after proper installation of a hood and cooktop or range. This extra space can be filled using Thermador stainless steel duct cover accessories or integrated with kitchen cabinetry. The space can also be adjusted by raising or lowering your hood within the recommended range (typically 30" to 36" above the cooking surface).

CHOOSING THE CORRECT BLOWER

A variety of interior and exterior blower options (Remote, Inline or Integrated) are available for Thermador Professional and Masterpiece® Series Hoods. If the unit you have selected does not have a blower, one can be purchased separately. Blower selection will vary based on the volume of air that needs to be moved and the length and location of the duct run. For long duct runs with multiple turns and bends, consider using a more powerful blower. For the most efficient air flow exhaust, use a straight run or as few elbows as possible.

Remote Blowers (VTR Series)

Depending on your preference and ducting situation, these blowers can be mounted on the roof or exterior wall of your home. An exterior installation may be more appealing to reduce noise in the kitchen.

Inline Blowers (VTI series)

To minimize noise in the kitchen, these blowers are mounted along the duct line anywhere between the kitchen and the exterior wall. If you have easy access to your duct line (in an attic, for example), this may be an appealing option.

Integrated Blowers (VTN series)

These blowers are purchased separately and integrated into the hood or onto the downdraft unit at the time of installation. This option allows you to select your ideal hood with the exact power you require. Integrated blowers are included with HPWB30FS, HPWB36FS and HPWB48FS.

SPECIAL NOTE: Always allow access to the blower for serviceability, should it be needed.

CHOOSING THE RIGHT CFM

The power of the cooktop or range, measured in BTU, is perhaps the most important factor in determining CFM needs for a hood.

You should also consider the cooking space and cooking style of your client.

- More demanding cooks usually require more exhaust capacity to handle moisture generated by boiling large pots of water or the grease and smoke resulting from grilling or frying. This cooking style could require a hood or downdraft system with airflow of 600 to 1,300 CFM.

- For those who are used to preparing quick meals in a relatively small kitchen, a hood with 600 CFM may be adequate ventilation for the cooking space.

- If the cooking surface is in a peninsula or island, a larger capacity hood can provide better capture when there are cross currents and when the hood needs to be mounted higher. Downdraft ventilation systems are also a good alternative.

- High heat cooking or aromatic foods may require additional CFM. Increasing capture area by 3" on each side is also a recommended way to address this issue.

LENGTH AND SIZE OF DUCTWORK

Do not use flexible duct; it creates back pressure / air turbulence and reduces performance.

Straight runs and gradual turns are best. Use the shortest route with the fewest turns possible.

Proper performance is dependent upon proper ducting. Use a qualified and trained installer. Local building codes may require the use of make-up air systems when using ducted ventilation systems greater than specified CFM of air movement. The specified CFM varies from locale to locale. Consult your HVAC professional for specific requirements in your area.

If using a 10" duct, Thermador recommends not exceeding 50 feet of duct. Transitions, elbows and wall or roof caps are all factors that will add more static pressure, therefore increasing your equivalent duct run.

WALL HOODS

	BLOWER INFORMATION						HOOD INFORMATION		
	Type	Model #	CFM	Total Amps (120V, 60Hz)	Roofplate Required	Duct Size at Blower	Transition w/Backdraft Damper	Duct Size at Discharge	Discharge Direction
PROFESSIONAL SERIES									
PH__GS 36" / 42" / 48" / 54"	Remote (Use Roof Jack RJ310)	VTR630P	600	12.1	RFPLT600P	6-Inch	Included	10-Inch	Vertical, Horizontal
		VTR1030P	1000	14.0	RFPLT1000P	10-Inch			
		VTR1330P	1300	17.5	RFPLT1000P	10-Inch			
	Inline (Use Wall Cap WC10)	VTI610P	600	12.1	—	6-Inch			
		VTI1010P	1000	14.0	—	10-Inch			
		Integrated (Use Wall Cap WC10)	VTN630N	600	10.3	—			
VTN1030N	1000		13.6	—	10-Inch				
PH60GS 60"	Remote (Use Roof Jack RJ310)	VTR1030P	1000	14.0	RFPLT1000P	10-Inch	Included	10-Inch	Vertical, Horizontal
		VTR1030P	1300	17.5	RFPLT1000P	10-Inch			
	Inline (Use Wall Cap WC10)	VTI1010P	1000	14.0	—	10-Inch			
		Integrated	VTN1090R	1000	13.1	—			
PH__HS 30" / 36" / 48"	Remote (Use Roof Jack RJ310)	VTR630P	600	6.9	RFPLT600P	6-Inch	Included	10-Inch	Vertical, Horizontal
		VTR1030P	1000	8.8	RFPLT1000P	10-Inch			
		VTR1330P	1300	12.3	RFPLT1000P	10-Inch			
	Inline	VTI610P	600	6.9	—	6-Inch			
		VTI1010P	1000	8.8	—	10-Inch			
		Integrated (Use Wall Cap WC10)	VTN630N	600	5.0	—			
VTN1030N	1000		8.4	—	10-Inch				
HPWB30FS 30" (Use Recirculation Kit RECIRC30FS)	Integrated	Included	600	3.4	—	10-Inch	Included	10-Inch	Vertical
HPWB__FS 36" / 48"	Integrated	Included	1200	10.2	—	10-Inch	Included	10-Inch	Vertical
MASTERPIECE® SERIES									
HMWN30FS 30" (Use Recirculation Kit RECIRC30FS)	Remote (Use Roof Jack RJ310)	VTR630P	600	4.3	RFPLT600P	6-Inch	Included	10-Inch	Vertical
		VTR1030P	1000	7.8	RFPLT1000P	10-Inch			
		VTR1330P	1300	12.3	RFPLT1000P	10-Inch			
	Inline	VTI610P	600	5.8	—	6-Inch			
		VTI1010P	1000	7.6	—	10-Inch			
Integrated	VTN600F	600	4.6	—	10-Inch				
HMWN__FS 36" / 48" (Use Recirculation Kit RECIRC36FS for 36" only)	Remote (Use Roof Jack RJ310)	VTR630P	600	4.3	RFPLT600P	6-Inch	Included	10-Inch	Vertical
		VTR1030P	1000	7.8	RFPLT1000P	10-Inch			
		VTR1330P	1300	9.2	RFPLT1000P	10-Inch			
	Inline	VTI610P	600	5.8	—	6-Inch			
		VTI1010P	1000	7.6	—	10-Inch			
	Integrated	VTN600F	600	4.6	—	10-Inch			
VTN1000F		1000	8.8	—	10-Inch				
HMWB__FS 30" / 36" (Use Recirculation Kit RECIRC30FS or RECIRC36FS)	Integrated	Included	600	3.4	—	10-Inch	Included	10-Inch	Vertical

BLOWER AND DUCT SELECTION GUIDE

PLANNING INFORMATION

	BLOWER INFORMATION						HOOD INFORMATION		
	Type	Model #	CFM	Total Amps (120V, 60Hz)	Roofplate Required	Duct Size at Blower	Transition w/Backdraft Damper	Duct Size at Discharge	Discharge Direction
CHIMNEY WALL HOODS									
PROFESSIONAL SERIES									
HPCN_NS 36" / 48"	Remote (Use Roof Jack RJ310)	VTR630P	600	6.7	RFPLT600P	6-Inch	Included	10-Inch	Vertical
		VTR1030P	1000	7.8	RFPLT1000P	10-Inch			
		VTR1330P	1300	9.2	RFPLT1000P	10-Inch			
	Inline	VTI610P	600	5.8	—	6-Inch			
		VTI1010P	1000	7.6	—	10-Inch			
Integrated	VTN1090R	1000	7.9	—	10-Inch				
HPCB_NS 36" / 48"	Integrated	Included	1000	7.9	—	10-Inch	Included	10-Inch	Vertical
MASTERPIECE® SERIES									
HMCN_FS 36" / 42"	Remote (Use Roof Jack RJ310)	VTR630P	600	6.7	RFPLT600P	6-Inch	Required*	8-Inch	Vertical
		VTR1030P	1000	7.8	RFPLT1000P	10-Inch			
		VTR1330P	1300	9.2	RFPLT1000P	10-Inch			
	Inline	VTI610P	600	5.8	—	6-Inch			
		VTI1010P	1000	7.6	—	10-Inch			
Integrated	VTN1080N	1000	7.9	—	8-Inch				
HMCB_FS 36" / 42"	Integrated	Included	600	4.9	—	6-Inch	Included	6-Inch	Vertical
HDDW36FS 36"	Integrated	Included	600	4.9	—	6-Inch	Included	6-Inch	Vertical

*Purchase separately at most hardware stores, unless otherwise indicated with a Thermador model number.

	BLOWER INFORMATION						HOOD INFORMATION		
	Type	Model #	CFM	Total Amps (120V, 60Hz)	Roofplate Required	Duct Size at Blower	Transition w/Backdraft Damper	Duct Size at Discharge	Discharge Direction
ISLAND HOODS									
PROFESSIONAL SERIES									
HPIN_HS 42" / 48"	Remote (Use Roof Jack RJ310)	VTR630P	600	Max 10	RFPLT600P	6-Inch	Included	6-Inch	Vertical
		VTR1030P	1000		RFPLT1000P	10-Inch			
		VTR1330P	1300		RFPLT1000P	10-Inch			
	Inline	VTI610P	600		—	6-Inch			
		VTI1010P	1000		—	10-Inch			
MASTERPIECE® SERIES									
HPIB_HS 42" / 48" (Use Recirculation Kit RECIRISL)	Integrated	Included	600	5.2	—	6-Inch	Included	6-Inch	Vertical
HMIB40HS 40" (Use Recirculation Kit RECIRISL)	Integrated	Included	600	4.9	—	6-Inch	Included	6-Inch	Vertical

BLOWER CONNECTOR CABLE

EXTNCB25

- 25 ft. Blower Connector Cable for use with the following Inline and Remote blowers: VTR630P, VTR1030P, VTR1330P, VTI610P, VTI1010P**

**Cannot be used with HPCB36NS, HPCB48NS, HMCN36FS, or HMCN42FS

BLOWER AND DUCT SELECTION GUIDE

PLANNING INFORMATION

	BLOWER INFORMATION						HOOD INFORMATION		
	Type	Model #	CFM	Total Amps (120V, 60Hz)	Roofplate Required	Duct Size at Blower	Transition w/Backdraft Damper	Duct Size at Discharge	Discharge Direction
CUSTOM INSERTS									
PROFESSIONAL SERIES									
VCIN_JP 36" / 48" / 54"	Remote (Use Roof Jack RJ310)	VTR630P	600	6.9	RFPLT600P	6-Inch	Included	10-Inch	Vertical
		VTR1030P	1000	8.8	RFPLT1000P	10-Inch			
		VTR1330P	1300	12.3	RFPLT1000P	10-Inch			
	Inline	VTI610P	600	6.9	—	6-Inch			
		VTI1010P	1000	8.8	—	10-Inch			
	Integrated	VTN630N	600	5.0	—	10-Inch			
VCIN60RP 60"	Remote (Use Roof Jack RJ310)	VTR1030P	1000	8.8	RFPLT1000P	10-Inch	Included	10-Inch	Vertical
		VTR1330P	1300	12.3	RFPLT1000P	10-Inch			
	Integrated	VTN1090R	1000	7.9	—	10-Inch			
VCIB_JP 36" / 48" / 54"	Integrated	Included	1000	12.7	—	10-Inch	Included	10-Inch	Vertical
MASTERPIECE® SERIES									
VCI2_DS 30" / 36" / 48"	Remote (Use Roof Jack RJ310)	VTR630P	600	5.2	RFPLT600P	6-Inch	Required*	10-Inch	Vertical
		VTR1030P	1000	7.8	RFPLT1000P	10-Inch			
		VTR1330P	1300	9.5	RFPLT1000P	10-Inch			
	Inline	VTI610P	600	6.9	—	6-Inch			
		VTI1010P	1000	8.8	—	10-Inch			
	Integrated (Inline blower can be used for an Integrated solution)	VTI610P	600	6.9	—	6-Inch			
	VTI1010P	1000	7.6	—	10-Inch				

*Purchase separately at most hardware stores, unless otherwise indicated with a Thermador model number.

	BLOWER INFORMATION						HOOD INFORMATION		
	Type	Model #	CFM	Total Amps (120V, 60Hz)	Roofplate Required	Duct Size at Blower	Transition w/Backdraft Damper	Duct Size at Discharge	Discharge Direction
DOWNDRAFTS									
MASTERPIECE® SERIES									
UCVM_FS 30" / 36" (Use Recirculation Kit RECIRC36DF for blower VTN600CV2C only)	Remote	VTR630P	600	6.7	RFPLT600P	6-Inch	CV2T6 Required*	6-Inch	Front Side, Front Down
		VTR1030P	1000	10.2	RFPLT1000P	10-Inch			
	Inline	VTI610P	600	5.8	—	6-Inch			
		VTI1010P	1000	7.6	—	10-Inch			
	Integrated	VTN600CV2C	600	6.7	—	6-Inch			

*Purchase separately at most hardware stores, unless otherwise indicated with a Thermador model number.

BLOWER CONNECTOR CABLE

EXTNCB25

- 25 ft. Blower Connector Cable for use with the following Inline and Remote blowers: VTR630P, VTR1030P, VTR1330P, VTI610P, VTI1010P

BLOWER DIMENSIONS

PLANNING INFORMATION

REMOTE BLOWERS (MOUNTED TO ROOF OR EXTERNAL WALL)

VTR630P – 600 CFM

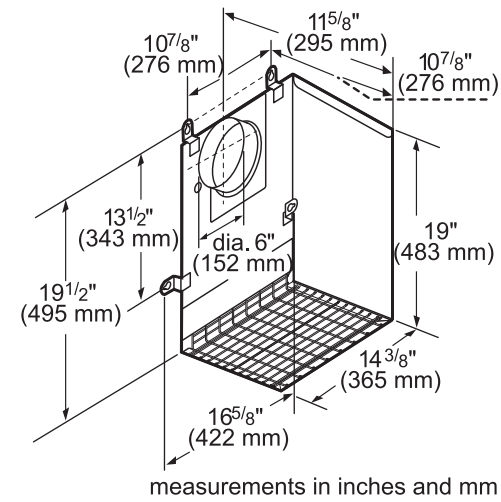

VTR1030P – 1000 CFM

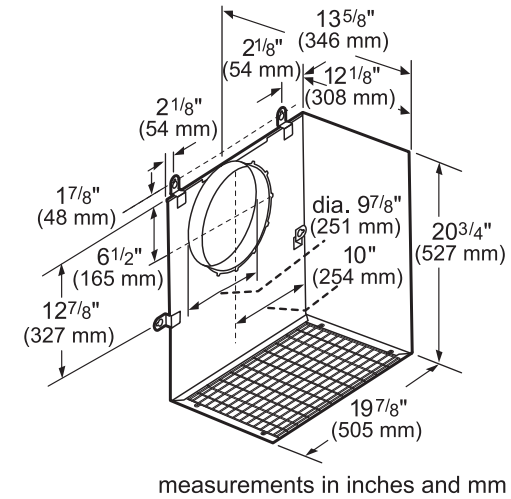

VTR1330P – 1300 CFM

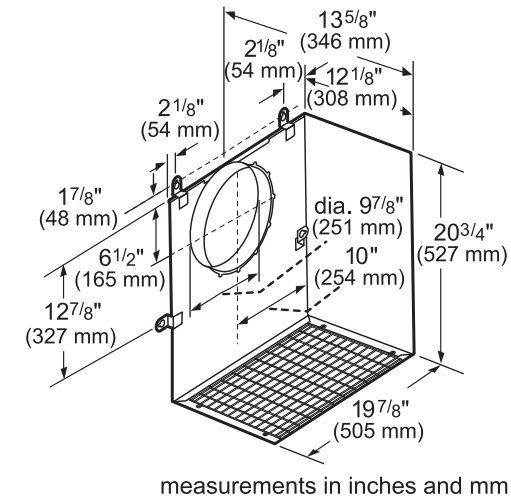

INLINE BLOWERS (MOUNTED BETWEEN KITCHEN AND EXTERNAL WALL)

VTI610P – 600 CFM

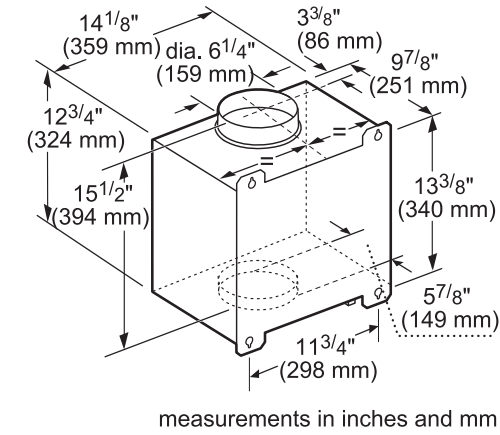

VTI1010P – 1000 CFM

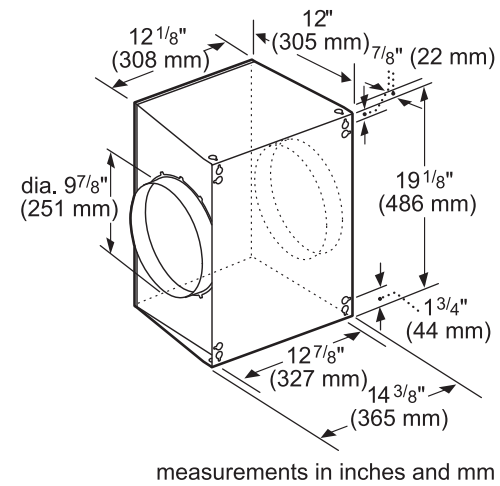

INTEGRATED BLOWERS (MOUNTED IN HOOD)

VTN630N – 600 CFM

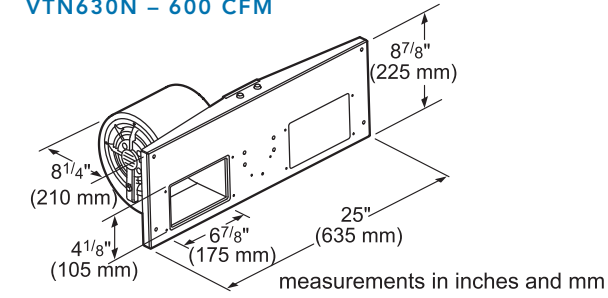

VTN1030N – 1000 CFM

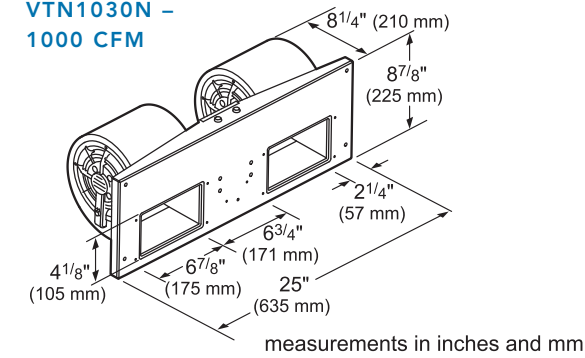

VTN1080N – 1000 CFM

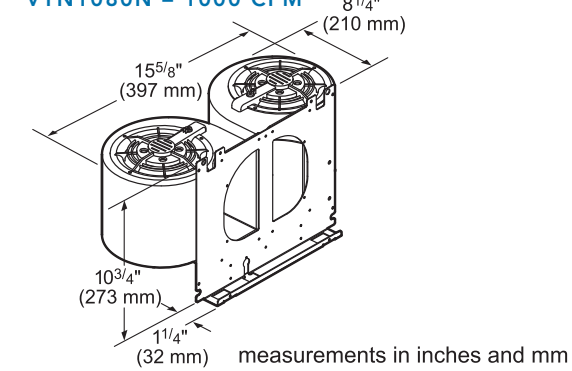

VTN1090R – 1000 CFM

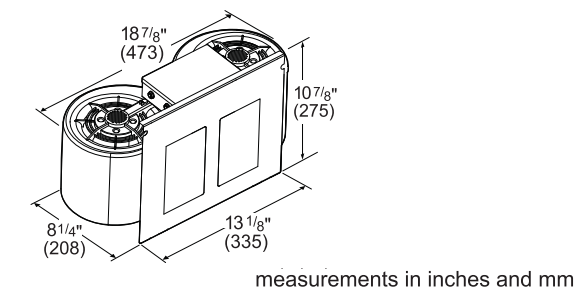

BLOWER DIMENSIONS

PLANNING INFORMATION

VTN600F – 600 CFM

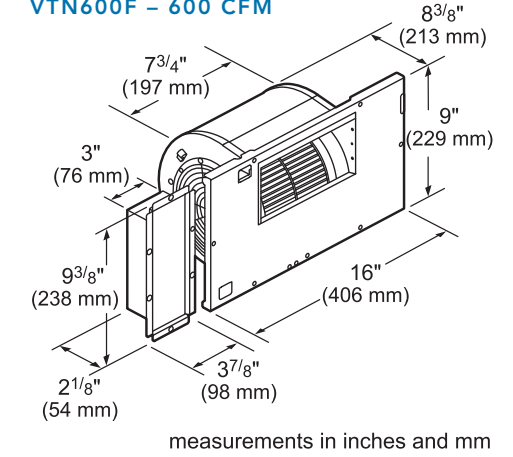

VTN1000F – 1000 CFM

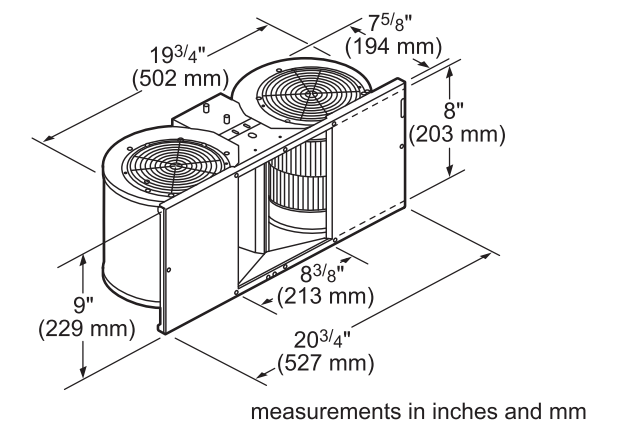

VTN600CV2C – 600 CFM

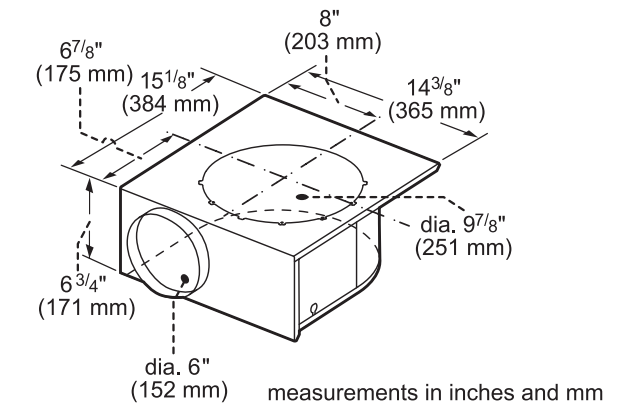

BLOWER OPTIONS AND PRESSURE CURVES

PLANNING INFORMATION

REMOTE (MOUNTED TO ROOF OR EXTERNAL WALL)

VTR630P – 600 CFM

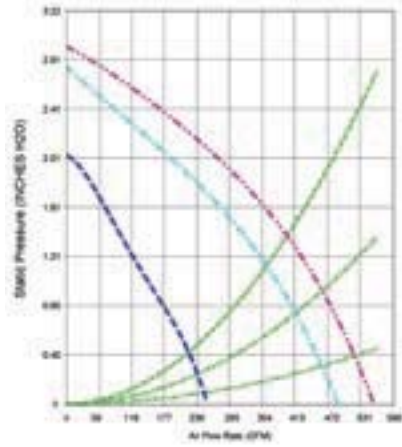

VTR1030P – 1000 CFM

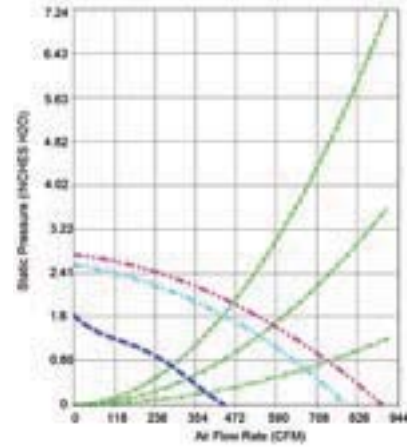

VTR1330P – 1300 CFM

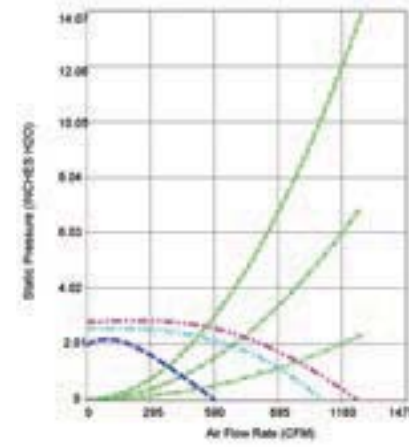

INLINE (MOUNTED BETWEEN KITCHEN AND EXTERNAL WALL)

VTI610P – 600 CFM

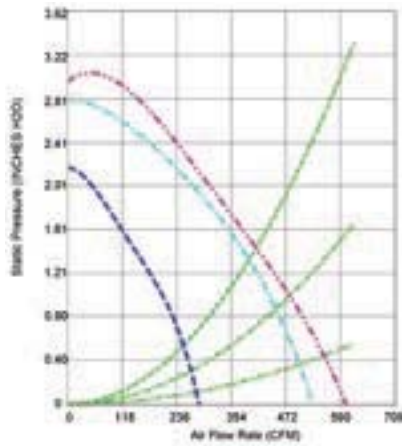

VTI1010P – 1000 CFM

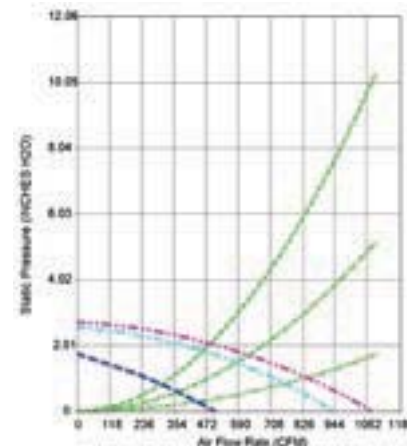

NOTE: All measurements are made with 3 ft. straight duct, 90° bend followed by 1 ft. straight duct. These are NOT free blowing measurements.

BLOWER OPTIONS AND PRESSURE CURVES

PLANNING INFORMATION

INTEGRATED (MOUNTED IN HOOD)

VTN600CV2C – 600 CFM

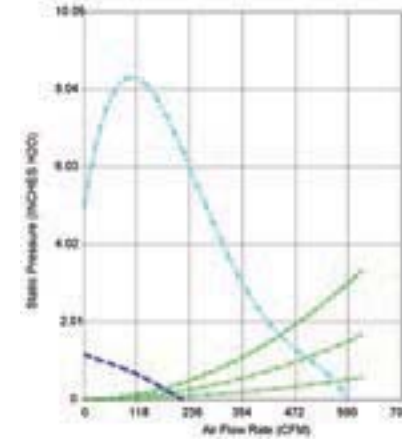

VTN600F – 600 CFM

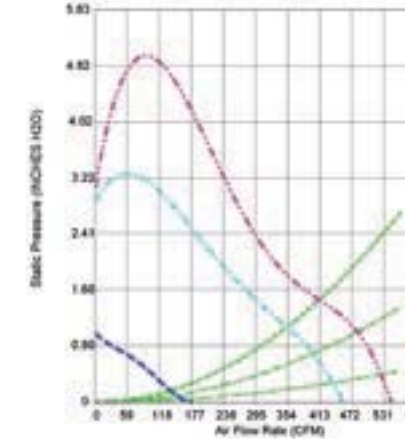

VTN630N – 600 CFM

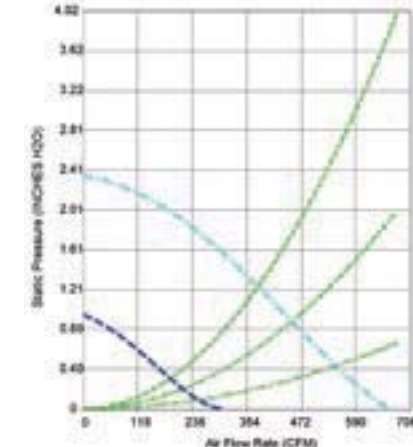

VTN1080N – 1000 CFM

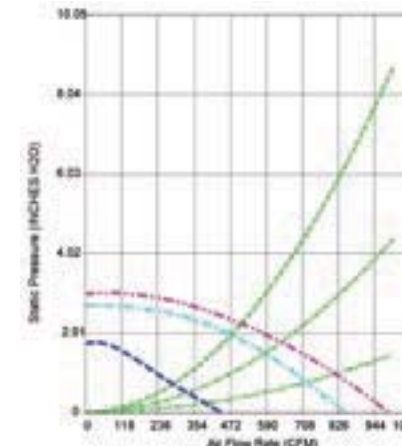

VTN1000F – 1000 CFM

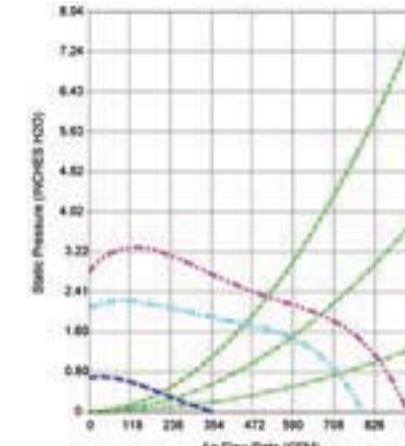

VTN1030N – 1000 CFM

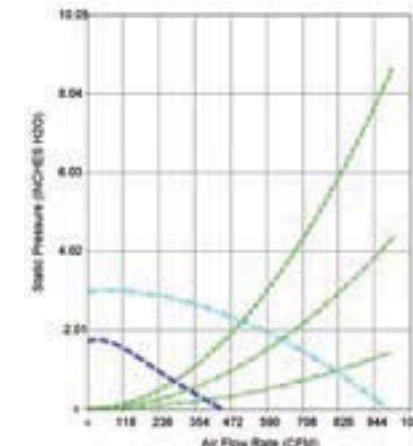

VTN1090R – 1000 CFM

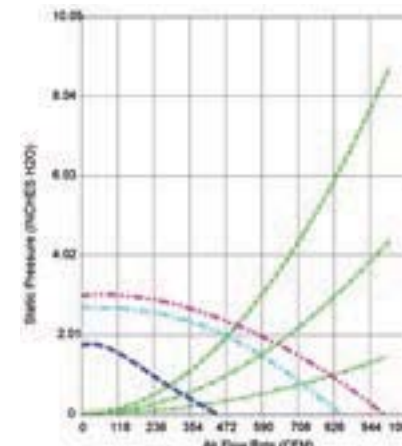

OPTIONAL BLOWER ACCESSORIES PLANNING INFORMATION

ROOFPLATE RFPLT600P

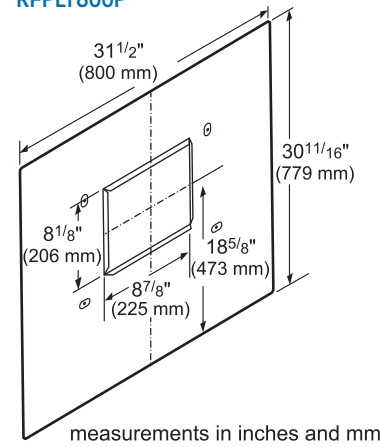

ROOFPLATE RFPLT1000P

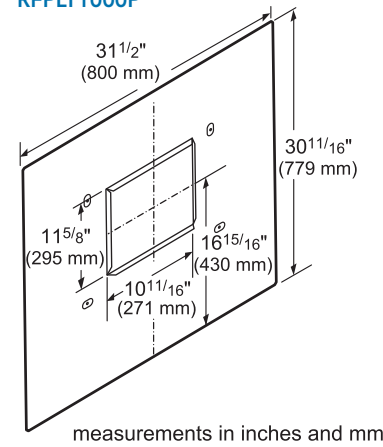

WALL CAPS

WC10

- 10" wall cap

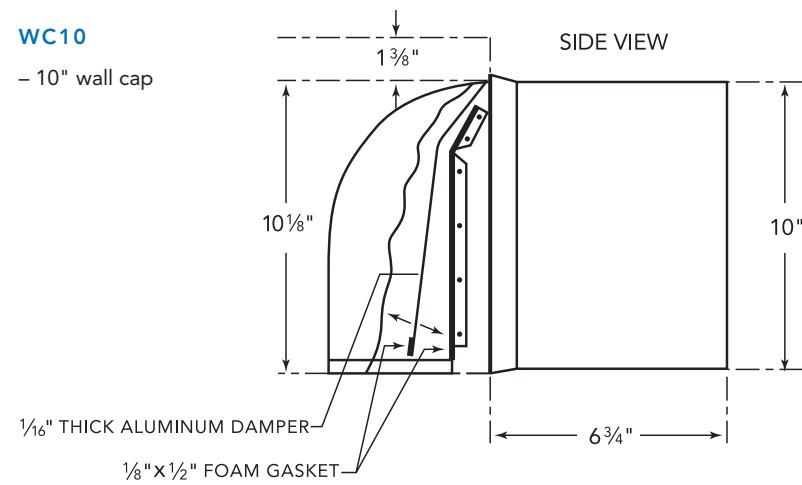

WC8

- 8" wall cap

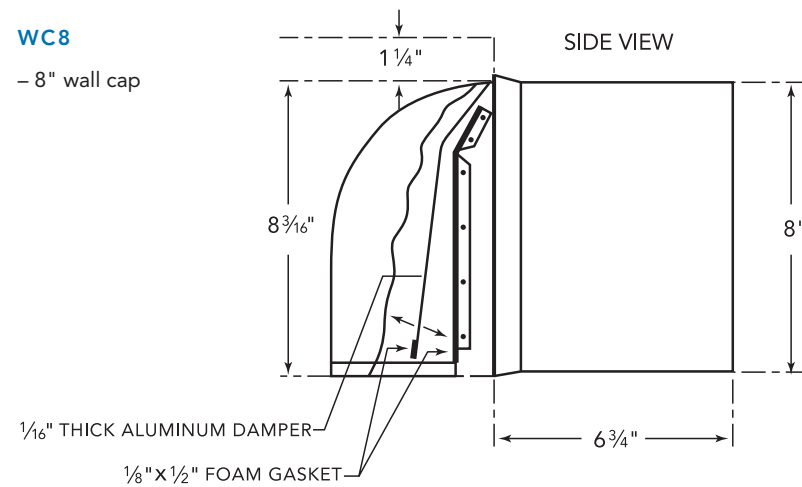

COMBINATIONS

Roofplate	Remote Blower
RFPLT600P	VTR630P
RFPLT1000P	VTR1030P, VTR1330P

EXTNCB25

- 25 ft. Blower Connector Cable for use with the following Inline and Remote blowers: VTR630P, VTR1030P, VTR1330P, VTI610P, VTI1010P*

*Cannot be used with HMCN36FS, HMCN42FS, HMWN30FS, HMWN36FS or HMWN48FS

ROOF JACK RJ310

- 3 1/4" x 10"

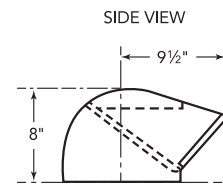

EQUIVALENT DUCT LENGTHS FOR COMMONLY USED TRANSITIONS PLANNING INFORMATION

DUCT PIECE	SIZE OF DUCT PIECE (IN.)	EQUIVALENT LENGTH (FT.)	DUCT PIECE	SIZE OF DUCT PIECE (IN.)	EQUIVALENT LENGTH (FT.)
Smooth Straight	6	1.2	3 1/4" x 10" to Round 90° Elbow	6	10
	7	0.95		7	5
	8	0.7	3 1/4" x 10" Center Reverse Elbow Left	N/A	15
	10	0.6		N/A	25
3 1/4" x 10" Straight	N/A	1	3 1/4" x 10" Center Reverse Elbow Right	N/A	25
3 1/4" x 14" Straight	N/A	0.7		3 1/4" x 10" Left Reverse Elbow	N/A
90° Elbow Round	6	12	3 1/4" x 10" Right Reverse Elbow		N/A
	7	8		Round Wall Cap	6
	8	6	7		2
45° Elbow Round	6	5	8	2	
	7	4	10	2	
	8	3	Round Roof Cap	6	2
3 1/4" x 10" 90° Elbow Round	N/A	5		7	2
	3 1/4" x 10" 45° Elbow Round	N/A		15	8
3 1/4" x 10" Flat Elbow		N/A	20	2' Long 3 1/4" x 10" Flex	N/A
	Round to 3 1/4" x 10"	6	1		3 1/4" x 10" to Round
7		1	7" Inline Backdraft Damper	7	
3 1/4" x 10" to Round	6	5		3 1/4" x 10" Roof Jack and Shutter	N/A
	7	3			
Round to 3 1/4" x 10" 90° Elbow	6	10			
	7	8			

NOTE: These commonly used installation parts can be purchased at a local hardware store. Thermador does not manufacture all these parts.

WALL HOODS

OPTIONAL ACCESSORIES

DUCT COVER

- For use with PH_GS, PH_HS, HPWB_FS, HMWN_FS and HMWB_FS
- Stainless steel duct cover for wall hood applications

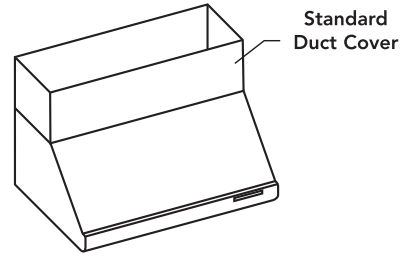

WIDTH	6-INCH HIGH	12-INCH HIGH
30-Inch	DC30US	DCT30US
36-Inch	DC36US	DCT36US
42-Inch	N/A	DCT42US
48-Inch	DC48US	DCT48US
54-Inch	N/A	N/A
60-Inch	N/A	N/A

REPLACEMENT CHARCOAL FILTERS

CHFILT3036

- For use with Recirculation Kit RECIRC_FS

LIGHTING

SKU	INCLUDED	BULB TYPE
PH_GS, PH_HS	Yes	120 V, 40 W - G9 Base
HPWB_FS, HMWN_FS, HMWB_FS	No	120 V, 50 W - GU10 Base

RECIRCULATION KIT

- Stainless steel finish
- Perfect for hard to duct installations
- Use with 600 CFM blowers only
- Adds 4" to total height of appliance

RECIRC30FS

30" WIDE

- For use with HPWB30FS, HMWN30FS, and HMWB30FS

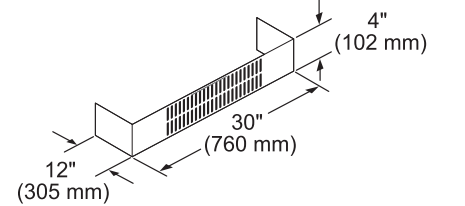

measurements in inches and mm

RECIRC36FS

36" WIDE

- For use with Masterpiece Hoods HMWN36FS and HMWB36FS

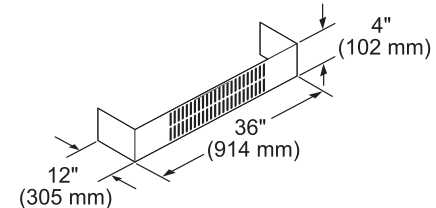

measurements in inches and mm

36-INCH DUCT COVER

- For use with HPCN_NS / HPCB_NS
- Stainless Steel Duct Covers in three different configurations

CHMHP366N

6" HIGH

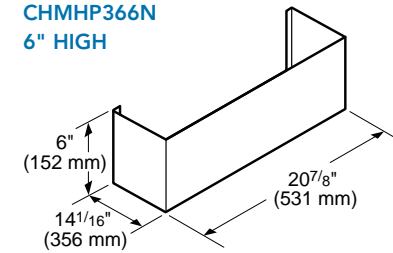

CHMHP3612N

12" HIGH

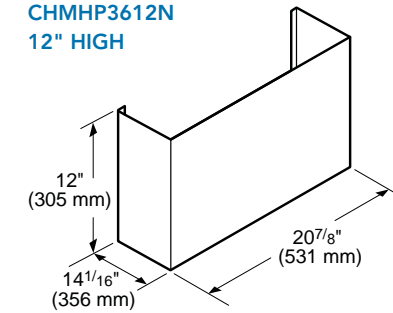

CHMHP36TSN

18" - 35" HIGH

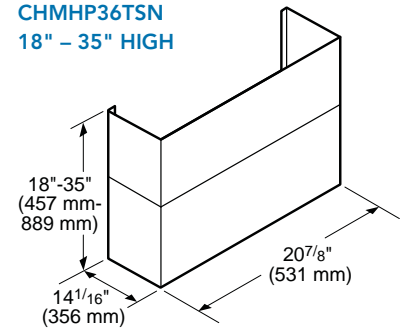

48-INCH DUCT COVER

- For use with HPCN_NS / HPCB_NS
- Stainless Steel Duct Covers in three different configurations

CHMHP486N

6" HIGH

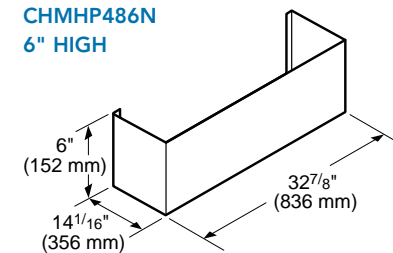

CHMHP4812N

12" HIGH

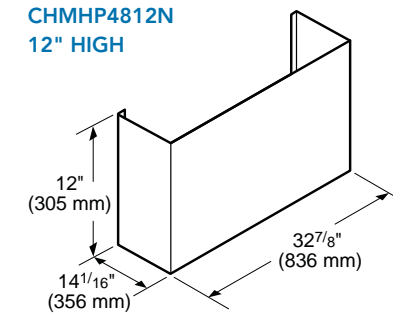

CHMHP48TSN

18" - 35" HIGH

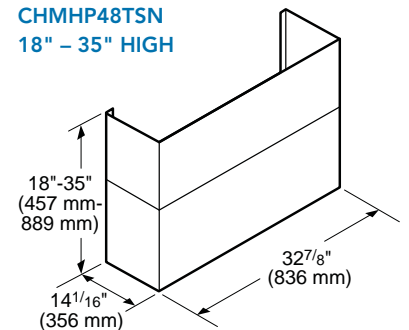

CHIMNEY EXTENSION

- Stainless steel chimney hood extension for up to 11-foot ceiling applications
- Extension replaces upper section of standard chimney extension
- May require fabrication to reduce height

CHIMXHMC

- For use with HMCN_FS and HMCB_FS

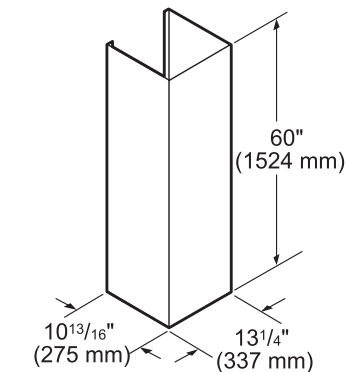

measurements in inches and mm

CHIMXHDD

- For use with HDDW36FS

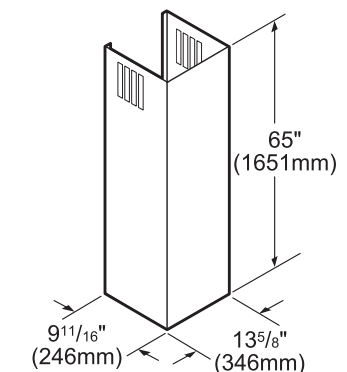

measurements in inches and mm

LIGHTING

SKU	INCLUDED	BULB TYPE
HPCN_NS, HPCB_NS	Yes	120 V, 40 W - G9 Base
HMCN_FS, HMCB_FS, HDDW36FS	Yes	12 V, 20 W - G4 Base

CHIMNEY WALL HOODS

OPTIONAL ACCESSORIES

ISLAND HOODS OPTIONAL ACCESSORIES

RECIRCULATION KIT

RECIRISL

- For use with HPIB__HS and HMIB40HS
- Stainless steel finish
- Perfect for hard to duct installations
- Use with 600 CFM blowers only



REPLACEMENT CHARCOAL FILTERS

CHFILISL

- For use with Recirculation Kit RECIRISL



LIGHTING

SKU	INCLUDED	BULB TYPE
HPIN__HS, HPIB__HS, HMIB40HS	Yes	120 V, 20 W - G4 Base

DOWNDRAFT OPTIONAL ACCESSORIES

RECIRCULATION KIT

RECIRC36DF

- Comes complete with 2 charcoal filters, 2 venting grids, and ducting to transition to integrated blower (blower sold separately)
- For toekick heights of 4" or taller
- Wall or island applications
- Easily mounts to integrated blower (VTN600CV2C) under cooktop
- Toekick / socket can be vented in any direction
- Mounts to base of cabinet; recesses into toekick
- To be used only with Thermador Downdraft and Integrated Blower
- Replacement filters are ordered as a service item
- Filters should be replaced twice a year

REPLACEMENT CHARCOAL FILTERS

- Sold separately as service item #291108 (For use with recirculation module)

TRANSITIONS

CV2T6

- Transition piece required for installation of 600 CFM Inline and Remote Blowers with 6" duct connections — downdraft applications only

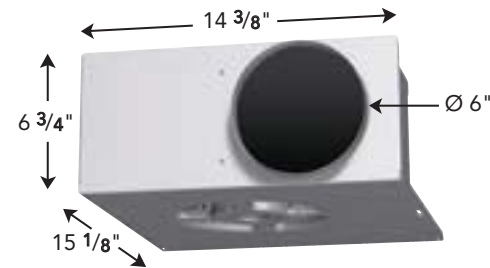

CV2T10

- Transition piece required for installation of 1000 CFM Inline and Remote Blowers with 10" duct connections - downdraft applications only

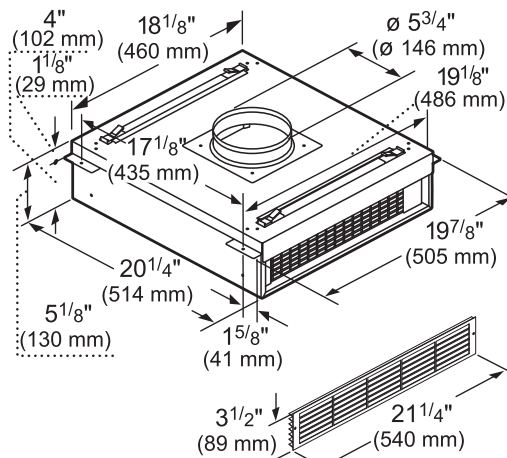
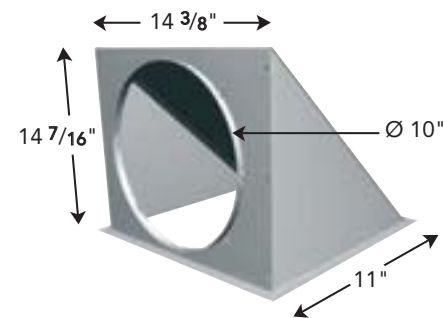

measurements in inches and mm



KITCHEN DESIGN BY: GLENN MEADER, GOOD LIFE NEW ENGLAND
 MODELS SHOWN: VCIB36JP 36-INCH PROFESSIONAL SERIES CUSTOM INSERT, PCG366G 36-INCH PROFESSIONAL RANGETOP, T18IF900SP 18-INCH FREEDOM FREEZER COLUMN AND T24IR900SP 24-INCH FREEDOM FRESH FOOD COLUMN

CUSTOM INSERTS

OPTIONAL ACCESSORIES

CUSTOM HOOD LINER

- LINER236 – FOR 36-INCH INSERT VCIN36JP
- LINER248 – FOR 48-INCH INSERT VCIN48JP
- LINER254 – FOR 54-INCH INSERT VCIN54JP

- Custom hood liner completes custom insert installation
- Wipes clean easily

NOTE: VCIN Custom Insert models include hood trim pieces. VCIN Custom Insert model installations that do not use the included trims may purchase the liner accessory to complete custom insert installation. Liner accessory adds 8 1/8" to overall width, and 4 1/8" to overall depth of appliance. See dimensional line drawings for more information.

36" LINER236

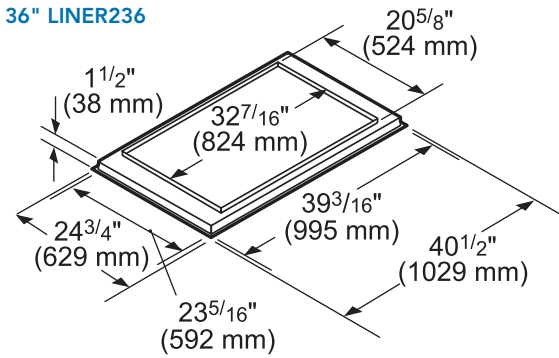

48" LINER248

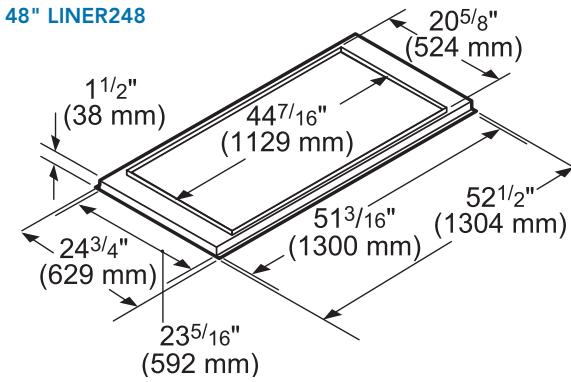

54" LINER254

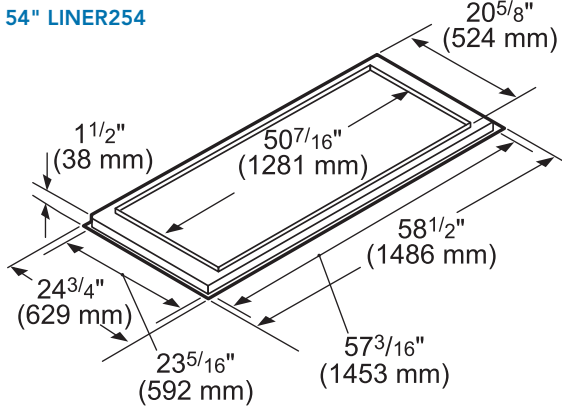

CUSTOM HOOD LINER

- LINER30 – FOR 30-INCH INSERT VCI230DS
- LINER36 – FOR 36-INCH INSERT VCI236DS
- LINER48 – FOR 48-INCH INSERT VCI248DS

- Stainless steel custom hood liner protects the exterior base of custom insert

30" LINER30

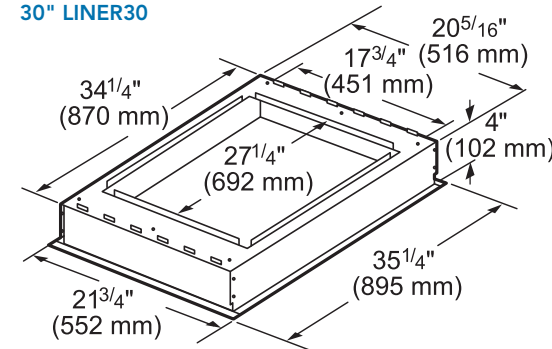

measurements in inches and mm

36" LINER36

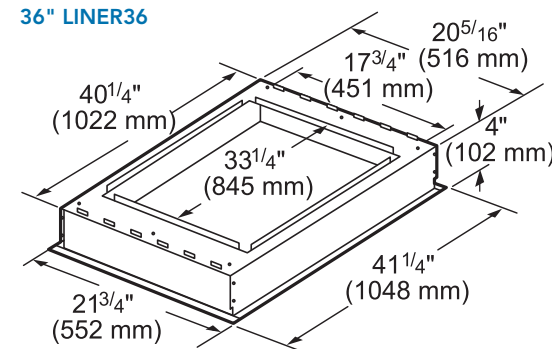

measurements in inches and mm

48" LINER48

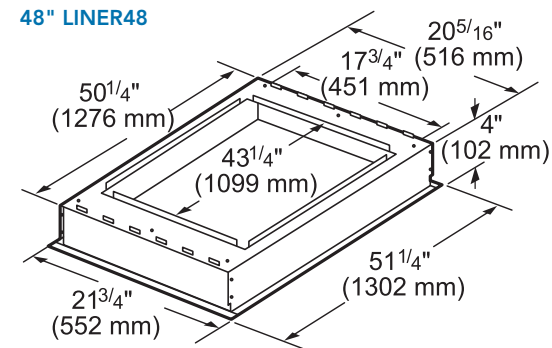

measurements in inches and mm

CUSTOM HOOD INSTALLATION TRIM

- 36" TRIMS236
- 48" TRIMS248
- 54" TRIMS254

- For use with VCIB__JP
- Stainless steel custom insert hood trims prevent heat and moisture build up inside the canopy
- Completes custom insert installation without using a liner
- Wipes clean easily

NOTE: VCIB Custom Insert models include a hood liner accessory. VCIB Custom Insert model installations that do not use the included liner may purchase the trims accessory to complete custom insert installation. See dimensional line drawings for more information.

REMOTE CONTROL PANEL

VCI2REMKS

- For use with VCIN__JP and VCIB__JP
- Stainless steel finish
- Cable-connected to blower and hood controls (operation of controls only from remote)
- Cable length 30 ft.

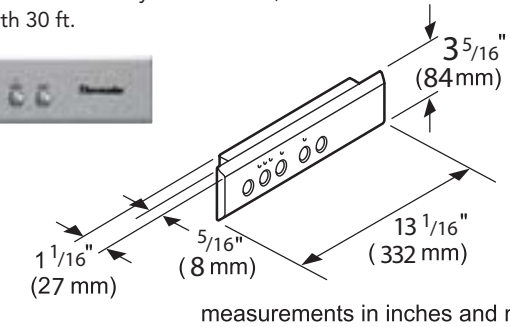

measurements in inches and mm

REMOTE CONTROL PANEL

VCI2REMFS

- For use with VCI2_DS
- Stainless steel finish
- Cable-connected to blower and hood controls (operation of controls only from remote)
- Cable length 13 ft.

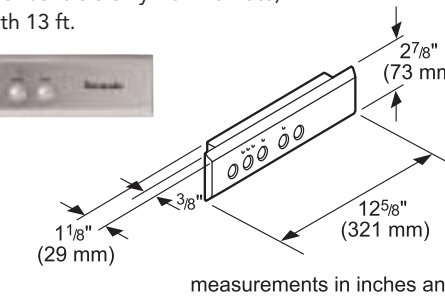

measurements in inches and mm

CUSTOM INSERTS

OPTIONAL ACCESSORIES

BAFFLE FILTER

- 30" BAFFLT30
- 36" BAFFLT36
- 48" BAFFLT48



- Stainless steel finish
- Unique low profile design maximizes grease capture
- Dishwasher-safe for easy cleanup

WALL CAPS

WC8

- 8" wall cap

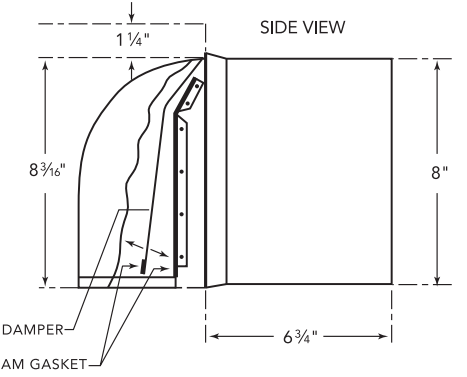

1/16" THICK ALUMINUM DAMPER
1/8" X 1/2" FOAM GASKET

LIGHTING

SKU	INCLUDED	BULB TYPE
VCIN__JP, VCIB__JP	Yes	120 V, 40 W - G9 Base
VCI2_DS	Yes	12 V, 20 W - G4 Base

VENTILATION

WALL HOODS



Wall Hoods VENTILATION

Thermador® Wall Hoods put the finishing touch on your cooking system, with deep capture areas for the best overall efficiency in drawing away smoke, moisture and heat. These elegant hoods combine style with vigorous performance, generating ventilation power from 600 to 1,300 CFM. Available in a variety of heights, widths and depths, they accommodate your individual venting needs. All models include brilliant halogen lighting for enhanced visibility and convenient speed controls. For ultra-simple cleanup, the removable filters and grease collection trays fit easily in your dishwasher.

POWERFUL VENTILATION

Breathe deeply with the air-freshening power of up to 1,300 CFM. Several models now have the blower included for ease of installation.

EXTERIOR CONTROLS

Easy-to-clean, easy-to-use push-button controls put accuracy at your fingertips.

DELAYED SHUT-OFF

For the greatest efficiency, our Professional ventilation models include delayed shut-off to tackle lingering odors. (Except HMWB30FS, HMWB36FS)

TIME-TO-CLEAN-FILTER LIGHT

Easy cleanup: all Thermador ventilation filters are dishwasher-safe, and many hoods feature a built-in Time-to-Clean-Filter reminder light. (Except HMWB30FS, HMWB36FS).

BAFFLE FILTERS

Unique low-profile, commercial-style baffle filters maximize grease capture without affecting flow, and they're dishwasher-safe for easy cleanup.

HALOGEN LIGHTS

Bright halogen lighting spotlights your best recipes.



PH36GS

27-INCH DEPTH WALL HOOD (36-INCH WIDTH)

PROFESSIONAL SERIES

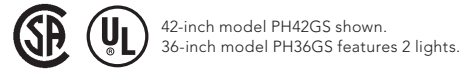

FEATURES & BENEFITS

- Three fan speeds
- Auto function senses heat from the cooking surface and adjusts fan speeds
- Powerfully Quiet ventilation systems
- Extended capture area ensures removal of smoke and odor
- Built-in 'Clean Filter' reminder light illuminates after 40 hours of operation
- 27" depth hood is a perfect companion to the Pro Grand Professional Range
- Delayed shut-off tackles lingering odors for up to 10 minutes
- Dimmer lighting – for a soft lighting effect
- Two infrared keep-hot lamps hold food warm until serving time

ACCESSORIES (OPTIONAL)

25 ft. Blower Connector Cable - EXTNCB25

For use with the following Inline and Remote Blowers: VTR630P, VTR1030P, VTR1330P, VTI610P, VTI1010P

Roofplates

RFPLT600P - For use with 600 CFM Remote Blower VTR630P

RFPLT1000P - For use with 1000 CFM Remote Blower VTR1030P and 1300 CFM Blower VTR1330P

36" W, 6" H Stainless Steel Duct Cover	DC36US
36" W, 12" H Stainless Steel Duct Cover	DCT36US
Roof Jack and Transition	RJ310
10" Wall Cap	WC10

GENERAL PROPERTIES

Operating Mode	Ducted
Maximum CFM	N/A
Number of Speed Settings	3-Stage
Motor Location	Blower (Sold Separately)
Number Of Lights	2
Bulb Type	40 W - G9 Base
Total Power Of The Lamps (W)	80 W
Damper Included	Yes
Grease Filter Material	Washable Stainless Steel
Grease Filter Type	Commercial-Style Baffle

TECHNICAL DETAILS

Watts (W)	N/A
Current (A)	15; 20 A
Volts (V)	120 V
Frequency (Hz)	60 HZ
Plug Type	120V-3 Prong

DIMENSIONS & WEIGHT

Overall Appliance Dimensions (Width Of Canopy Included) (HxWxD) (in)	18" x 35 15/16" x 27"
Required Distance Above Cooktop / Range Cooking Surface	30" / 30"
Diameter of Air Duct (in) Top	10"
Diameter of Air Duct (in) Back	10"
Net Weight (lbs)	80 lbs

ACCESSORIES (REQUIRED)

Blower (Sold Separately)

BLOWER OPTIONS

Remote Blower (Mounted to Roof or External Wall)	VTR630P - 600 CFM
	VTR1030P - 1000 CFM
	VTR1330P - 1300 CFM
Inline Blower (Mounted Between Kitchen and External Wall)	VTI610P - 600 CFM
	VTI1010P - 1000 CFM
Integrated Blower (Mounted in Hood)	VTN630N - 600 CFM
	VTN1030N - 1000 CFM

WARRANTY

Limited Warranty Parts And Labor	2 Year
----------------------------------	--------

PH42GS

27-INCH DEPTH WALL HOOD (42-INCH WIDTH)

PROFESSIONAL SERIES



FEATURES & BENEFITS

- Three fan speeds
- Auto function senses heat from the cooking surface and adjusts fan speeds
- Powerfully Quiet ventilation systems
- Extended capture area ensures removal of smoke and odor
- Built-in 'Clean Filter' reminder light illuminates after 40 hours of operation
- 27" depth hood is a perfect companion to the Pro Grand Professional Range
- Delayed shut-off tackles lingering odors for up to 10 minutes
- Dimmer lighting – for a soft lighting effect
- Two infrared keep-hot lamps hold food warm until serving time

ACCESSORIES (OPTIONAL)

25 ft. Blower Connector Cable - EXTNCB25

For use with the following Inline and Remote Blowers: VTR630P, VTR1030P, VTR1330P, VTI610P, VTI1010P

Roofplates

RFPLT600P - For use with 600 CFM Remote Blower VTR630P

RFPLT1000P - For use with 1000 CFM Remote Blower VTR1030P and 1300 CFM Blower VTR1330P

42" W, 12" H Stainless Steel Duct Cover	DCT42US
Roof Jack and Transition	RJ310
10" Wall Cap	WC10

GENERAL PROPERTIES

Operating Mode	Ducted
Maximum CFM	N/A
Number of Speed Settings	3-Stage
Motor Location	Blower (Sold Separately)
Number Of Lights	4
Bulb Type	40 W - G9 Base
Total Power Of The Lamps (W)	160 W
Damper Included	Yes
Grease Filter Material	Washable Stainless Steel
Grease Filter Type	Commercial-Style Baffle

TECHNICAL DETAILS

Watts (W)	N/A
Current (A)	15; 20 A
Volts (V)	120 V
Frequency (Hz)	60 HZ
Plug Type	120V-3 Prong

DIMENSIONS & WEIGHT

Overall Appliance Dimensions (Width Of Canopy Included) (HxWxD) (in)	18" x 41 15/16" x 27"
Required Distance Above Cooktop / Range Cooking Surface	30" / 30"
Diameter of Air Duct (in) Top	10"
Diameter of Air Duct (in) Back	10"
Net Weight (lbs)	85 lbs

ACCESSORIES (REQUIRED)

Blower (Sold Separately)

BLOWER OPTIONS

Remote Blower (Mounted to Roof or External Wall)	VTR630P - 600 CFM
	VTR1030P - 1000 CFM
	VTR1330P - 1300 CFM
Inline Blower (Mounted Between Kitchen and External Wall)	VTI610P - 600 CFM
	VTI1010P - 1000 CFM
Integrated Blower (Mounted in Hood)	VTN630N - 600 CFM
	VTN1030N - 1000 CFM

WARRANTY

Limited Warranty Parts And Labor	2 Year
----------------------------------	--------

PH48GS

27-INCH DEPTH WALL HOOD (48-INCH WIDTH)

PROFESSIONAL SERIES



FEATURES & BENEFITS

- Three fan speeds
- Auto function senses heat from the cooking surface and adjusts fan speeds
- Powerfully Quiet ventilation systems
- Extended capture area ensures removal of smoke and odor
- Built-in 'Clean Filter' reminder light illuminates after 40 hours of operation
- 27" depth hood is a perfect companion to the Pro Grand Professional Range
- Delayed shut-off tackles lingering odors for up to 10 minutes
- Dimmer lighting – for a soft lighting effect
- Two infrared keep-hot lamps hold food warm until serving time

ACCESSORIES (OPTIONAL)

25 ft. Blower Connector Cable - EXTNCB25

For use with the following Inline and Remote Blowers: VTR630P, VTR1030P, VTR1330P, VTI610P, VTI1010P

Roofplates

RFPLT600P - For use with 600 CFM Remote Blower VTR630P

RFPLT1000P - For use with 1000 CFM Remote Blower VTR1030P and 1300 CFM Blower VTR1330P

48" W, 6" H Stainless Steel Duct Cover	DC48US
48" W, 12" H Stainless Steel Duct Cover	DCT48US
Roof Jack and Transition	RJ310
10" Wall Cap	WC10

GENERAL PROPERTIES

Operating Mode	Ducted
Maximum CFM	N/A
Number of Speed Settings	3-Stage
Motor Location	Blower (Sold Separately)
Number Of Lights	4
Bulb Type	40 W - G9 Base
Total Power Of The Lamps (W)	160 W
Damper Included	Yes
Grease Filter Material	Washable Stainless Steel
Grease Filter Type	Commercial-Style Baffle

TECHNICAL DETAILS

Watts (W)	N/A
Current (A)	15; 20 A
Volts (V)	120 V
Frequency (Hz)	60 HZ
Plug Type	120V-3 Prong

DIMENSIONS & WEIGHT

Overall Appliance Dimensions (Width Of Canopy Included) (HxWxD) (in)	18" x 47 15/16" x 27"
Required Distance Above Cooktop / Range Cooking Surface	30" / 30"
Diameter of Air Duct (in) Top	10"
Diameter of Air Duct (in) Back	10"
Net Weight (lbs)	98 lbs

ACCESSORIES (REQUIRED)

Blower (Sold Separately)

BLOWER OPTIONS

Remote Blower (Mounted to Roof or External Wall)	VTR630P - 600 CFM
	VTR1030P - 1000 CFM
	VTR1330P - 1300 CFM
Inline Blower (Mounted Between Kitchen and External Wall)	VTI610P - 600 CFM
	VTI1010P - 1000 CFM
Integrated Blower (Mounted in Hood)	VTN630N - 600 CFM
	VTN1030N - 1000 CFM

WARRANTY

Limited Warranty Parts And Labor	2 Year
----------------------------------	--------

PH54GS

27-INCH DEPTH WALL HOOD (54-INCH WIDTH)

PROFESSIONAL SERIES



FEATURES & BENEFITS

- Three fan speeds
- Auto function senses heat from the cooking surface and adjusts fan speeds
- Powerfully Quiet ventilation systems
- Extended capture area ensures removal of smoke and odor
- Built-in 'Clean Filter' reminder light illuminates after 40 hours of operation
- 27" depth hood is a perfect companion to the Pro Grand Professional Range
- Delayed shut-off tackles lingering odors for up to 10 minutes
- Dimmer lighting – for a soft lighting effect
- Two infrared keep-hot lamps hold food warm until serving time

ACCESSORIES (OPTIONAL)

25 ft. Blower Connector Cable - EXTNCB25

For use with the following Inline and Remote Blowers: VTR630P, VTR1030P, VTR1330P, VTI610P, VTI1010P

Roofplates

RFPLT600P - For use with 600 CFM Remote Blower VTR630P

RFPLT1000P - For use with 1000 CFM Remote Blower VTR1030P and 1300 CFM Blower VTR1330P

Roof Jack and Transition	RJ310
10" Wall Cap	WC10

GENERAL PROPERTIES

Operating Mode	Ducted
Maximum CFM	N/A
Number of Speed Settings	3-Stage
Motor Location	Blower (Sold Separately)
Number Of Lights	4
Bulb Type	40 W - G9 Base
Total Power Of The Lamps (W)	160 W
Damper Included	Yes
Grease Filter Material	Washable Stainless Steel
Grease Filter Type	Commercial-Style Baffle

TECHNICAL DETAILS

Watts (W)	N/A
Current (A)	15; 20 A
Volts (V)	120 V
Frequency (Hz)	60 HZ
Plug Type	120V-3 Prong

DIMENSIONS & WEIGHT

Overall Appliance Dimensions (Width Of Canopy Included) (HxWxD) (in)	18" x 54" x 27"
Required Distance Above Cooktop / Range Cooking Surface	30" / 30"
Diameter of Air Duct (in) Top	10"
Diameter of Air Duct (in) Back	10"
Net Weight (lbs)	111 lbs

ACCESSORIES (REQUIRED)

Blower (Sold Separately)

BLOWER OPTIONS

Remote Blower (Mounted to Roof or External Wall)	VTR630P - 600 CFM
	VTR1030P - 1000 CFM
	VTR1330P - 1300 CFM
Inline Blower (Mounted Between Kitchen and External Wall)	VTI610P - 600 CFM
	VTI1010P - 1000 CFM
Integrated Blower (Mounted in Hood)	VTN630N - 600 CFM
	VTN1030N - 1000 CFM

WARRANTY

Limited Warranty Parts And Labor	2 Year
----------------------------------	--------

PH60GS

27-INCH DEPTH WALL HOOD (60-INCH WIDTH)

PROFESSIONAL SERIES



FEATURES & BENEFITS

- Three fan speeds
- Auto function senses heat from the cooking surface and adjusts fan speeds
- Powerfully Quiet ventilation systems
- Extended capture area ensures removal of smoke and odor
- Built-in 'Clean Filter' reminder light illuminates after 40 hours of operation
- 27" depth hood is a perfect companion to the Pro Grand Professional Range
- Delayed shut-off tackles lingering odors for up to 10 minutes
- Dimmer lighting – for a soft lighting effect
- Two infrared keep-hot lamps hold food warm until serving time

ACCESSORIES (OPTIONAL)

25 ft. Blower Connector Cable - EXTNCB25

For use with the following Inline and Remote Blowers: VTR1030P, VTR1330P, VTI1010P

Roofplates

RFPLT1000P - For use with 1000 CFM Remote Blower VTR1030P and 1300 CFM Blower VTR1330P

Roof Jack and Transition	RJ310
10" Wall Cap	WC10

GENERAL PROPERTIES	
Operating Mode	Ducted
Maximum CFM	N/A
Number of Speed Settings	3-Stage
Motor Location	Blower (Sold Separately)
Number Of Lights	4
Bulb Type	40 W - G9 Base
Total Power Of The Lamps (W)	160 W
Damper Included	Yes
Grease Filter Material	Washable Stainless Steel
Grease Filter Type	Commercial-Style Baffle

TECHNICAL DETAILS	
Watts (W)	N/A
Current (A)	15; 20 A
Volts (V)	120 V
Frequency (Hz)	60 HZ
Plug Type	120V-3 Prong

DIMENSIONS & WEIGHT	
Overall Appliance Dimensions (Width Of Canopy Included) (HxWxD) (in)	18" x 60" x 27"
Required Distance Above Cooktop / Range Cooking Surface	30" / 30"
Diameter of Air Duct (in) Top	10"
Diameter of Air Duct (in) Back	10"
Net Weight (lbs)	123 lbs

ACCESSORIES (REQUIRED)	
Blower (Sold Separately)	

BLOWER OPTIONS	
Remote Blower (Mounted to Roof or External Wall)	VTR1030P - 1000 CFM
	VTR1330P - 1300 CFM
Inline Blower (Mounted Between Kitchen and External Wall)	VTI1010P - 1000 CFM
Integrated Blower (Mounted in Hood)	VTN1090R - 1000 CFM

WARRANTY	
Limited Warranty Parts And Labor	2 Year

PH30HS

24-INCH DEPTH WALL HOOD (30-INCH WIDTH)

PROFESSIONAL SERIES



FEATURES & BENEFITS

- Three fan speeds
- Delayed shut-off tackles lingering odors for up to 10 minutes
- Built-in 'Clean Filter' reminder light illuminates after 40 hours of operation
- Filter systems are highly efficient at capturing grease
- Dishwasher-safe grease collection trays are easily removed
- 24" depth hood is 18" tall and a perfect companion with Pro Harmony Ranges and Rangetops
- Dimmer lighting – for a soft lighting effect

ACCESSORIES (OPTIONAL)

25 ft. Blower Connector Cable - EXTNCB25

For use with the following Inline and Remote Blowers: VTR630P, VTR1030P, VTR1330P, VTI610P, VTI1010P

Roofplates

RFPLT600P - For use with 600 CFM Remote Blower VTR630P

RFPLT1000P - For use with 1000 CFM Remote Blower VTR1030P and 1300 CFM Blower VTR1330P

30" W, 6" H Stainless Steel Duct Cover	DC30US
30" W, 12" H Stainless Steel Duct Cover	DCT30US
Roof Jack and Transition	RJ310
10" Wall Cap	WC10

GENERAL PROPERTIES	
Operating Mode	Ducted
Maximum CFM	N/A
Number of Speed Settings	3-Stage
Motor Location	Blower (Sold Separately)
Number Of Lights	2
Bulb Type	40 W - G9 Base
Total Power Of The Lamps (W)	80 W
Damper Included	Yes
Grease Filter Material	Washable Stainless Steel
Grease Filter Type	Commercial-Style Baffle

TECHNICAL DETAILS	
Watts (W)	N/A
Current (A)	15; 20 A
Volts (V)	120 V
Frequency (Hz)	60 HZ
Plug Type	120V-3 Prong

DIMENSIONS & WEIGHT	
Overall Appliance Dimensions (Width Of Canopy Included) (HxWxD) (in)	18" x 29 15/16" x 24"
Required Distance Above Cooktop / Range Cooking Surface	30" / 30"
Diameter of Air Duct (in) Top	10"
Diameter of Air Duct (in) Back	10"
Net Weight (lbs)	70 lbs

ACCESSORIES (REQUIRED)	
Blower (Sold Separately)	

BLOWER OPTIONS	
Remote Blower (Mounted to Roof or External Wall)	VTR630P - 600 CFM
	VTR1030P - 1000 CFM
	VTR1330P - 1300 CFM
Inline Blower (Mounted Between Kitchen and External Wall)	VTI610P - 600 CFM
	VTI1010P - 1000 CFM
Integrated Blower (Mounted in Hood)	VTN630N - 600 CFM
	VTN1030N - 1000 CFM

WARRANTY	
Limited Warranty Parts And Labor	2 Year

PH36HS
24-INCH DEPTH WALL HOOD (36-INCH WIDTH)
PROFESSIONAL SERIES



FEATURES & BENEFITS

- Three fan speeds
- Delayed shut-off tackles lingering odors for up to 10 minutes
- Built-in 'Clean Filter' reminder light illuminates after 40 hours of operation
- Filter systems are highly efficient at capturing grease
- Dishwasher-safe grease collection trays are easily removed
- 24" depth hood is 18" tall and a perfect companion with Pro Harmony Ranges and Rangetops
- Dimmer lighting – for a soft lighting effect

ACCESSORIES (OPTIONAL)

25 ft. Blower Connector Cable - EXTNCB25

For use with the following Inline and Remote Blowers: VTR630P, VTR1030P, VTR1330P, VT1610P, VT11010P

Roofplates

RFPLT600P - For use with 600 CFM Remote Blower VTR630P

RFPLT1000P - For use with 1000 CFM Remote Blower VTR1030P and 1300 CFM Blower VTR1330P

36" W, 6" H Stainless Steel Duct Cover	DC36US
36" W, 12" H Stainless Steel Duct Cover	DCT36US
Roof Jack and Transition	RJ310
10" Wall Cap	WC10

GENERAL PROPERTIES	
Operating Mode	Ducted
Maximum CFM	N/A
Number of Speed Settings	3-Stage
Motor Location	Blower (Sold Separately)
Number Of Lights	2
Bulb Type	40 W - G9 Base
Total Power Of The Lamps (W)	80 W
Damper Included	Yes
Grease Filter Material	Washable Stainless Steel
Grease Filter Type	Commercial-Style Baffle

TECHNICAL DETAILS	
Watts (W)	N/A
Current (A)	15; 20 A
Volts (V)	120 V
Frequency (Hz)	60 HZ
Plug Type	120V-3 Prong

DIMENSIONS & WEIGHT	
Overall Appliance Dimensions (Width Of Canopy Included) (HxWxD) (in)	18" x 35 15/16" x 24"
Required Distance Above Cooktop / Range Cooking Surface	30" / 30"
Diameter of Air Duct (in) Top	10"
Diameter of Air Duct (in) Back	10"
Net Weight (lbs)	75 lbs

ACCESSORIES (REQUIRED)

Blower (Sold Separately)

BLOWER OPTIONS	
Remote Blower (Mounted to Roof or External Wall)	VTR630P - 600 CFM
	VTR1030P - 1000 CFM
	VTR1330P - 1300 CFM
Inline Blower (Mounted Between Kitchen and External Wall)	VT1610P - 600 CFM
	VT11010P - 1000 CFM
Integrated Blower (Mounted in Hood)	VTN630N - 600 CFM
	VTN1030N - 1000 CFM

WARRANTY	
Limited Warranty Parts And Labor	2 Year

PH48HS
24-INCH DEPTH WALL HOOD (48-INCH WIDTH)
PROFESSIONAL SERIES



FEATURES & BENEFITS

- Three fan speeds
- Delayed shut-off tackles lingering odors for up to 10 minutes
- Built-in 'Clean Filter' reminder light illuminates after 40 hours of operation
- Filter systems are highly efficient at capturing grease
- Dishwasher-safe grease collection trays are easily removed
- 24" depth hood is 18" tall and a perfect companion with Pro Harmony Ranges and Rangetops
- Dimmer lighting – for a soft lighting effect

ACCESSORIES (OPTIONAL)

25 ft. Blower Connector Cable - EXTNCB25

For use with the following Inline and Remote Blowers: VTR630P, VTR1030P, VTR1330P, VT1610P, VT11010P

Roofplates

RFPLT600P - For use with 600 CFM Remote Blower VTR630P

RFPLT1000P - For use with 1000 CFM Remote Blower VTR1030P and 1300 CFM Blower VTR1330P

48" W, 6" H Stainless Steel Duct Cover	DC48US
48" W, 12" H Stainless Steel Duct Cover	DCT48US
Roof Jack and Transition	RJ310
10" Wall Cap	WC10

GENERAL PROPERTIES	
Operating Mode	Ducted
Maximum CFM	N/A
Number of Speed Settings	3-Stage
Motor Location	Blower (Sold Separately)
Number Of Lights	4
Bulb Type	40 W - G9 Base
Total Power Of The Lamps (W)	160 W
Damper Included	Yes
Grease Filter Material	Washable Stainless Steel
Grease Filter Type	Commercial-Style Baffle

TECHNICAL DETAILS	
Watts (W)	N/A
Current (A)	15; 20 A
Volts (V)	120 V
Frequency (Hz)	60 HZ
Plug Type	120V-3 Prong

DIMENSIONS & WEIGHT	
Overall Appliance Dimensions (Width Of Canopy Included) (HxWxD) (in)	18" x 47 15/16" x 24"
Required Distance Above Cooktop / Range Cooking Surface	30" / 30"
Diameter of Air Duct (in) Top	10"
Diameter of Air Duct (in) Back	10"
Net Weight (lbs)	94 lbs

ACCESSORIES (REQUIRED)

Blower (Sold Separately)

BLOWER OPTIONS	
Remote Blower (Mounted to Roof or External Wall)	VTR630P - 600 CFM
	VTR1030P - 1000 CFM
	VTR1330P - 1300 CFM
Inline Blower (Mounted Between Kitchen and External Wall)	VT1610P - 600 CFM
	VT11010P - 1000 CFM
Integrated Blower (Mounted in Hood)	VTN630N - 600 CFM
	VTN1030N - 1000 CFM

WARRANTY	
Limited Warranty Parts And Labor	2 Year

HPWB30FS
24-INCH DEPTH WALL HOOD WITH BLOWER
(30-INCH WIDTH)
 PROFESSIONAL SERIES



FEATURES & BENEFITS

- 600 CFM Integrated Blower included
- Recirculation possible with kit RECIRC30FS (max 600 CFM)
- Three fan speeds
- Delayed shut-off tackles lingering odors for up to 10 minutes
- Built-in 'Clean Filter' reminder light illuminates after 30 hours of operation

ACCESSORIES (OPTIONAL)

Recirculation Kit	
RECIRC30FS - For HPWB30FS, HMWB30FS and HMWN30FS 30" Hoods Only. Adds 4" to total height of appliance	
Replacement Charcoal Filter - CHFILT3036 For Use With Recirculation Kit RECIRC_FS	
30" W, 6" H Stainless Steel Duct Cover	DC30US
30" W, 12" H Stainless Steel Duct Cover	DCT30US

GENERAL PROPERTIES

Operating Mode	Convertible: Ducted / Recirculating
Maximum CFM	600 CFM
Number of Speed Settings	3-Stage
Motor Location	Integrated
Number Of Lights	Lights Sold Separately - 2
Bulb Type	50 W - GU10 Base
Total Power Of The Lamps (W)	100 W
Damper Included	Yes
Grease Filter Material	Washable Synthetic
Grease Filter Type	Multilayer Cassette

TECHNICAL DETAILS

Watts (W)	550 W
Current (A)	15 A
Volts (V)	120 V
Frequency (Hz)	60 HZ
Plug Type	Fixed Connection

DIMENSIONS & WEIGHT

Overall Appliance Dimensions (Width Of Canopy Included) (HxWxD) (in)	11" x 30" x 23 1/8"
Required Distance Above Cooktop / Range Cooking Surface	30" / 30"
Diameter of Air Duct (in) Top	10"
Diameter of Air Duct (in) Back	N/A
Net Weight (lbs)	35 lbs

ACCESSORIES (REQUIRED)

Recirculation Kit	
-------------------	--

BLOWER OPTIONS

Remote Blower (Mounted to Roof or External Wall)	N/A
	N/A
	N/A
Inline Blower (Mounted Between Kitchen and External Wall)	N/A
	N/A
Integrated Blower (Mounted in Hood)	N/A
	N/A

WARRANTY

Limited Warranty Parts And Labor	2 Year
----------------------------------	--------

HPWB36FS
24-INCH DEPTH WALL HOOD WITH BLOWER
(36-INCH WIDTH)
 PROFESSIONAL SERIES



FEATURES & BENEFITS

- 1,200 CFM Integrated Blower included
- Three fan speeds
- Delayed shut-off tackles lingering odors for up to 10 minutes
- Built-in 'Clean Filter' reminder light illuminates after 30 hours of operation

ACCESSORIES (OPTIONAL)

36" W, 6" H Stainless Steel Duct Cover	DC36US
36" W, 12" H Stainless Steel Duct Cover	DCT36US

GENERAL PROPERTIES

Operating Mode	Ducted
Maximum CFM	1,200 CFM
Number of Speed Settings	3-Stage
Motor Location	Integrated
Number Of Lights	Lights Sold Separately - 2
Bulb Type	50 W - GU10 Base
Total Power Of The Lamps (W)	100 W
Damper Included	Yes
Grease Filter Material	Washable Synthetic
Grease Filter Type	Multilayer Cassette

TECHNICAL DETAILS

Watts (W)	550 W
Current (A)	15 A
Volts (V)	120 V
Frequency (Hz)	60 HZ
Plug Type	Fixed Connection

DIMENSIONS & WEIGHT

Overall Appliance Dimensions (Width Of Canopy Included) (HxWxD) (in)	11" x 36" x 23 1/8"
Required Distance Above Cooktop / Range Cooking Surface	30" / 30"
Diameter of Air Duct (in) Top	10"
Diameter of Air Duct (in) Back	N/A
Net Weight (lbs)	33 lbs

BLOWER OPTIONS

Remote Blower (Mounted to Roof or External Wall)	N/A
	N/A
	N/A
Inline Blower (Mounted Between Kitchen and External Wall)	N/A
	N/A
Integrated Blower (Mounted in Hood)	N/A
	N/A

WARRANTY

Limited Warranty Parts And Labor	2 Year
----------------------------------	--------

HPWB48FS
24-INCH DEPTH WALL HOOD WITH BLOWER
(48-INCH WIDTH)
 PROFESSIONAL SERIES



FEATURES & BENEFITS

- 1,200 CFM Integrated Blower included
- Three fan speeds
- Delayed shut-off tackles lingering odors for up to 10 minutes
- Built-in 'Clean Filter' reminder light illuminates after 40 hours of operation

ACCESSORIES (OPTIONAL)

48" W, 6" H Stainless Steel Duct Cover	DC48US
48" W, 12" H Stainless Steel Duct Cover	DCT48US

GENERAL PROPERTIES

Operating Mode	Ducted
Maximum CFM	1,200 CFM
Number of Speed Settings	3-Stage
Motor Location	Integrated
Number Of Lights	Lights Sold Separately - 3
Bulb Type	50 W - GU10 Base
Total Power Of The Lamps (W)	150 W
Damper Included	Yes
Grease Filter Material	Washable Synthetic
Grease Filter Type	Multilayer Cassette

TECHNICAL DETAILS

Watts (W)	1,050 W
Current (A)	15 A
Volts (V)	120 V
Frequency (Hz)	60 HZ
Plug Type	Fixed Connection

DIMENSIONS & WEIGHT

Overall Appliance Dimensions (Width Of Canopy Included) (HxWxD) (in)	11" x 48" x 23 1/8"
Required Distance Above Cooktop / Range Cooking Surface	30" / 30"
Diameter of Air Duct (in) Top	10"
Diameter of Air Duct (in) Back	N/A
Net Weight (lbs)	30 lbs

BLOWER OPTIONS

Remote Blower (Mounted to Roof or External Wall)	N/A
	N/A
	N/A
Inline Blower (Mounted Between Kitchen and External Wall)	N/A
	N/A
Integrated Blower (Mounted in Hood)	N/A
	N/A

WARRANTY

Limited Warranty Parts And Labor	2 Year
----------------------------------	--------

HMWN30FS
WALL HOOD (30-INCH WIDTH)
 MASTERPIECE® SERIES



FEATURES & BENEFITS

- Recirculation possible with kit RECIRC30FS (max 600 CFM)
- Three fan speeds
- Built-in 'Clean Filter' reminder light illuminates after 40 hours of operation
- Delayed shut-off tackles lingering odors for up to 10 minutes
- Dishwasher-safe hybrid mesh filters

ACCESSORIES (OPTIONAL)

Roofplates	
RFPLT600P - For use with 600 CFM Remote Blower VTR630P	
RFPLT1000P - For use with 1000 CFM Remote Blower VTR1030P and 1300 CFM Blower VTR1330P	
Recirculation Kit	
RECIRC30FS - For HPWB30FS, HMWB30FS and HMWN30FS 30" Hoods Only. Adds 4" to height of appliance	
Replacement Charcoal Filter - CHFILT3036	
For Use With Recirculation Kit RECIRC_FS	
30" W, 6" H Stainless Steel Duct Cover	DC30US
30" W, 12" H Stainless Steel Duct Cover	DCT30US

GENERAL PROPERTIES

Operating Mode	Convertible: Ducted / Recirculating
Maximum CFM	N/A
Number of Speed Settings	3-Stage
Motor Location	Blower (Sold Separately)
Number Of Lights	Lights Sold Separately - 2
Bulb Type	50 W - GU10 Base
Total Power Of The Lamps (W)	100 W
Damper Included	Yes
Grease Filter Material	Washable Synthetic
Grease Filter Type	Multilayer Cassette

TECHNICAL DETAILS

Watts (W)	100 W
Current (A)	15 A
Volts (V)	120 V
Frequency (Hz)	60 HZ
Plug Type	Fixed Connection

DIMENSIONS & WEIGHT

Overall Appliance Dimensions (Width Of Canopy Included) (HxWxD) (in)	11" x 30" x 23 1/8"
Required Distance Above Cooktop / Range Cooking Surface	30" / 30"
Diameter of Air Duct (in) Top	10"
Diameter of Air Duct (in) Back	N/A
Net Weight (lbs)	35 lbs

ACCESSORIES (REQUIRED)

Blower (Sold Separately)

BLOWER OPTIONS

Remote Blower (Mounted to Roof or External Wall)	VTR630P - 600 CFM
	VTR1030P - 1000 CFM
	VTR1330P - 1300 CFM
Inline Blower (Mounted Between Kitchen and External Wall)	VTI610P - 600 CFM
	VTI1010P - 1000 CFM
Integrated Blower (Mounted in Hood)	VTN600F - 600 CFM

WARRANTY

Limited Warranty Parts And Labor	2 Year
----------------------------------	--------

HMWN36FS

WALL HOOD (36-INCH WIDTH)

MASTERPIECE® SERIES



FEATURES & BENEFITS

- Three fan speeds
- Built-in 'Clean Filter' reminder light illuminates after 40 hours of operation
- Delayed shut-off tackles lingering odors for up to 10 minutes
- Dishwasher-safe hybrid mesh filters
- Recirculation possible with kit RECIRC36FS (max 600 CFM)

ACCESSORIES (OPTIONAL)

Roofplates

RFPLT600P - For use with 600 CFM Remote Blower VTR630P

RFPLT1000P - For use with 1000 CFM Remote Blower VTR1030P and 1300 CFM Blower VTR1330P

Recirculation Kit

RECIRC36FS - For Masterpiece HMWB36FS and HMWN36FS 36" Hoods Only. Adds 4" to height of appliance

36" W, 6" H Stainless Steel Duct Cover DC36US

36" W, 12" H Stainless Steel Duct Cover DCT36US



GENERAL PROPERTIES

Operating Mode	Convertible: Ducted / Recirculating
Maximum CFM	N/A
Number of Speed Settings	3-Stage
Motor Location	Blower (Sold Separately)
Number Of Lights	Lights Sold Separately - 2
Bulb Type	50 W - GU10 Base
Total Power Of The Lamps (W)	100 W
Damper Included	Yes
Grease Filter Material	Washable Synthetic
Grease Filter Type	Multilayer Cassette

TECHNICAL DETAILS

Watts (W)	100 W
Current (A)	15 A
Volts (V)	120 V
Frequency (Hz)	60 HZ
Plug Type	Fixed Connection

DIMENSIONS & WEIGHT

Overall Appliance Dimensions (Width Of Canopy Included) (HxWxD) (in)	11" x 36" x 23 1/8"
Required Distance Above Cooktop / Range Cooking Surface	30" / 30"
Diameter of Air Duct (in) Top	10"
Diameter of Air Duct (in) Back	N/A
Net Weight (lbs)	33 lbs

ACCESSORIES (REQUIRED)

Blower (Sold Separately)

BLOWER OPTIONS

Remote Blower (Mounted to Roof or External Wall)	VTR630P - 600 CFM
	VTR1030P - 1000 CFM
	VTR1330P - 1300 CFM
Inline Blower (Mounted Between Kitchen and External Wall)	VTI610P - 600 CFM
	VTI1010P - 1000 CFM
Integrated Blower (Mounted in Hood)	VTN600F - 600 CFM

WARRANTY

Limited Warranty Parts And Labor	2 Year
----------------------------------	--------

HMWN48FS

WALL HOOD (48-INCH WIDTH)

MASTERPIECE® SERIES



FEATURES & BENEFITS

- Three fan speeds
- Built-in 'Clean Filter' reminder light illuminates after 40 hours of operation
- Delayed shut-off tackles lingering odors for up to 10 minutes
- Dishwasher-safe hybrid mesh filters

ACCESSORIES (OPTIONAL)

Roofplates

RFPLT600P - For use with 600 CFM Remote Blower VTR630P

RFPLT1000P - For use with 1000 CFM Remote Blower VTR1030P and 1300 CFM Blower VTR1330P

48" W, 6" H Stainless Steel Duct Cover DC48US

48" W, 12" H Stainless Steel Duct Cover DCT48US



GENERAL PROPERTIES

Operating Mode	Ducted
Maximum CFM	N/A
Number of Speed Settings	3-Stage
Motor Location	Blower (Sold Separately)
Number Of Lights	Lights Sold Separately - 3
Bulb Type	50 W - GU10 Base
Total Power Of The Lamps (W)	100 W
Damper Included	Yes
Grease Filter Material	Washable Synthetic
Grease Filter Type	Multilayer Cassette

TECHNICAL DETAILS

Watts (W)	150 W
Current (A)	15 A
Volts (V)	120 V
Frequency (Hz)	60 HZ
Plug Type	Fixed Connection

DIMENSIONS & WEIGHT

Overall Appliance Dimensions (Width Of Canopy Included) (HxWxD) (in)	11" x 48" x 23 1/8"
Required Distance Above Cooktop / Range Cooking Surface	30" / 30"
Diameter of Air Duct (in) Top	10"
Diameter of Air Duct (in) Back	N/A
Net Weight (lbs)	30 lbs

ACCESSORIES (REQUIRED)

Blower (Sold Separately)

BLOWER OPTIONS

Remote Blower (Mounted to Roof or External Wall)	VTR630P - 600 CFM
	VTR1030P - 1000 CFM
	VTR1330P - 1300 CFM
Inline Blower (Mounted Between Kitchen and External Wall)	VTI610P - 600 CFM
	VTI1010P - 1000 CFM
Integrated Blower (Mounted in Hood)	VTN600F - 600 CFM
	VTN1000F - 1000 CFM

WARRANTY

Limited Warranty Parts And Labor	2 Year
----------------------------------	--------

HMWB30FS

WALL HOOD WITH BLOWER (30-INCH WIDTH)

MASTERPIECE® SERIES



FEATURES & BENEFITS

- 600 CFM Integrated Blower included
- Recirculation possible with kit RECIRC30FS (max 600 CFM)
- Three fan speeds
- Built-in 'Clean Filter' reminder light illuminates after 40 hours of operation

ACCESSORIES (OPTIONAL)

Recirculation Kit	
RECIRC30FS - For HPWB30FS, HMWB30FS and HMWN30FS 30" Hoods Only. Adds 4" to height of appliance	
Replacement Charcoal Filter - CHFILT3036	
For Use With Recirculation Kit RECIRC_FS	
30" W, 6" H Stainless Steel Duct Cover	DC30US
30" W, 12" H Stainless Steel Duct Cover	DCT30US

GENERAL PROPERTIES

Operating Mode	Convertible: Ducted / Recirculating
Maximum CFM	600 CFM
Number of Speed Settings	3-Stage
Motor Location	Integrated
Number Of Lights	Lights Sold Separately - 2
Bulb Type	50 W - GU10 Base
Total Power Of The Lamps (W)	100 W
Damper Included	Yes
Grease Filter Material	Washable Synthetic
Grease Filter Type	Multilayer Cassette

TECHNICAL DETAILS

Watts (W)	550 W
Current (A)	15 A
Volts (V)	120 V
Frequency (Hz)	60 HZ
Plug Type	Fixed Connection

DIMENSIONS & WEIGHT

Overall Appliance Dimensions (Width Of Canopy Included) (HxWxD) (in)	11" x 30" x 23 1/8"
Required Distance Above Cooktop / Range Cooking Surface	30" / 30"
Diameter of Air Duct (in) Top	10"
Diameter of Air Duct (in) Back	N/A
Net Weight (lbs)	35 lbs

ACCESSORIES (REQUIRED)

Recirculation Kit

BLOWER OPTIONS

Remote Blower (Mounted to Roof or External Wall)	N/A
	N/A
	N/A
Inline Blower (Mounted Between Kitchen and External Wall)	N/A
	N/A
Integrated Blower (Mounted in Hood)	N/A
	N/A

WARRANTY

Limited Warranty Parts And Labor	2 Year
----------------------------------	--------

HMWB36FS

WALL HOOD WITH BLOWER (36-INCH WIDTH)

MASTERPIECE® SERIES



FEATURES & BENEFITS

- 600 CFM Integrated Blower included
- Recirculation possible with kit RECIRC36FS (max 600 CFM)
- Three fan speeds
- Built-in 'Clean Filter' reminder light illuminates after 40 hours of operation

ACCESSORIES (OPTIONAL)

Recirculation Kit	
RECIRC36FS - For Masterpiece HMWB36FS and HMWN36FS 36" Hoods Only. Adds 4" to height of appliance	
Replacement Charcoal Filter - CHFILT3036	
For Use With Recirculation Kit RECIRC_FS	
36" W, 6" H Stainless Steel Duct Cover	DC36US
36" W, 12" H Stainless Steel Duct Cover	DCT36US

GENERAL PROPERTIES

Operating Mode	Convertible: Ducted / Recirculating
Maximum CFM	600 CFM
Number of Speed Settings	3-Stage
Motor Location	Integrated
Number Of Lights	Lights Sold Separately - 2
Bulb Type	50 W - GU10 Base
Total Power Of The Lamps (W)	100 W
Damper Included	Yes
Grease Filter Material	Washable Synthetic
Grease Filter Type	Multilayer Cassette

TECHNICAL DETAILS

Watts (W)	550 W
Current (A)	15 A
Volts (V)	120 V
Frequency (Hz)	60 HZ
Plug Type	Fixed Connection

DIMENSIONS & WEIGHT

Overall Appliance Dimensions (Width Of Canopy Included) (HxWxD) (in)	11" x 36" x 23 1/8"
Required Distance Above Cooktop / Range Cooking Surface	30" / 30"
Diameter of Air Duct (in) Top	10"
Diameter of Air Duct (in) Back	N/A
Net Weight (lbs)	33 lbs

ACCESSORIES (REQUIRED)

Recirculation Kit

BLOWER OPTIONS

Remote Blower (Mounted to Roof or External Wall)	N/A
	N/A
	N/A
Inline Blower (Mounted Between Kitchen and External Wall)	N/A
	N/A
Integrated Blower (Mounted in Hood)	N/A
	N/A

WARRANTY

Limited Warranty Parts And Labor	2 Year
----------------------------------	--------

WALL HOODS

PLANNING INFORMATION

MODEL OPTIONS

When selecting a ventilation system, choose from one of our two sophisticated appliance collections. Select Professional Series for the ultimate in cooking and venting power or the Masterpiece® Series for its sleek styling and numerous convenience functions. Thermador Wall Hoods are available in various depths and heights to fit your kitchen plans and are meticulously crafted for both function and design. Be sure to reference the correct model information in this design guide.

ELECTRICAL SPECIFICATIONS

Be sure your Thermador Wall Hood is properly installed and grounded by a qualified technician. Installation, electrical connections and grounding must comply with all applicable local codes.

Install a suitable conduit box (not furnished). An appropriately-sized, UL-listed conduit connector must be used to correctly attach the conduit to the junction box. Remote blowers require a 5-wire installation.

MODEL	REQUIRED CIRCUIT BREAKER
	120V AC, 60 Hz
PH36GS	15; 20 A
PH42GS	15; 20 A
PH48GS	15; 20 A
PH54GS	15; 20 A
PH60GS	15; 20 A
PH30HS	15; 20 A
PH36HS	15; 20 A
PH48HS	15; 20 A
HPWB30FS	15 A
HPWB36FS	15 A
HPWB48FS	15 A
HMWN30FS	15 A
HMWN36FS	15 A
HMWN48FS	15 A
HMWB30FS	15 A
HMWB36FS	15 A

INSTALLATION CONSIDERATIONS

The information in this design guide provides key features, product dimensions, cutouts and installation specifications. Before installing a Thermador Wall Hood, be sure to verify the cutout dimensions and electrical connections. Also, always consult with the installation manual packed with the product for complete details before installing.

INSTALLATION OPTIONS

Thermador Wall Hoods may be installed above a Thermador Range or Cooktop to create a convenient cooking center. Refer to the ventilation selection guide for compatibility.

Hood installation height above a range or cooktop can vary. To obtain the necessary installation height above a Thermador Range or Cooktop, consult the appliance's installation manual. Accessory 6" and / or 12" tall duct covers are used to fill the space between the hood and ceiling.

Thermador Wall Hoods can be mounted on a wall or suspended from a cabinet. The cabinet must be structurally joined to the wall studs to support the weight of this hood.

TRANSITIONS

- Included with PH_GS models and PH_HS models
- 10" round downdraft transition
- Required for installation of 1000 and 1300 CFM inline and remote blowers

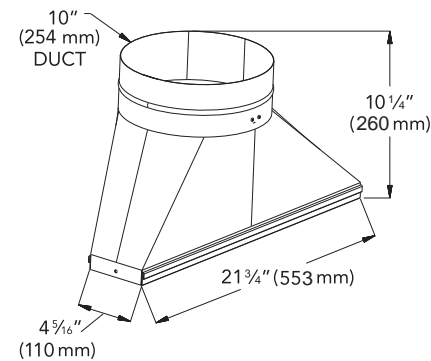

- Included with PH60GS

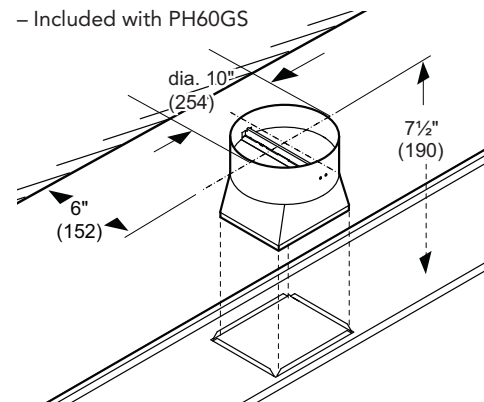

WALL HOODS

INSTALLATION

PH36GS 27-INCH DEPTH WALL HOOD (36-INCH WIDTH)

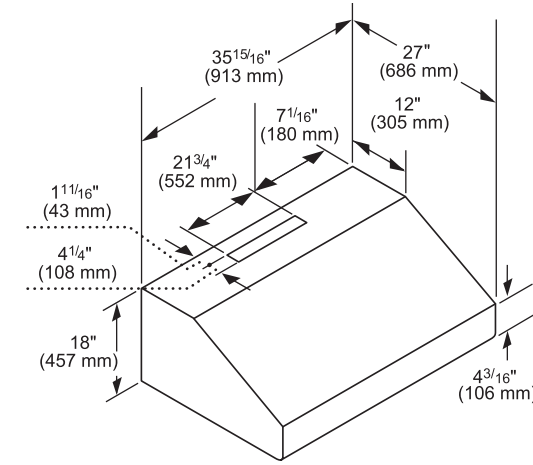

measurements in inches and mm

PH54GS 27-INCH DEPTH WALL HOOD (54-INCH WIDTH)

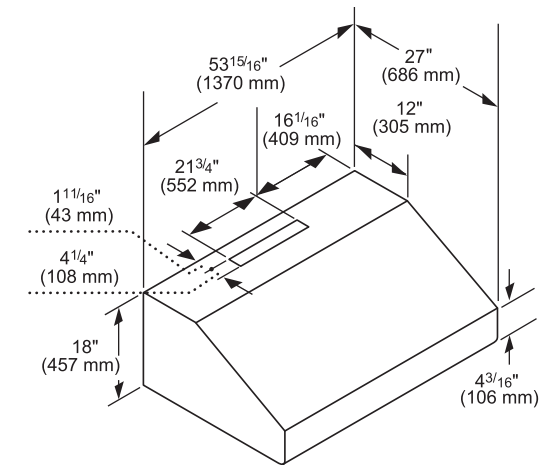

measurements in inches and mm

PH42GS 27-INCH DEPTH WALL HOOD (42-INCH WIDTH)

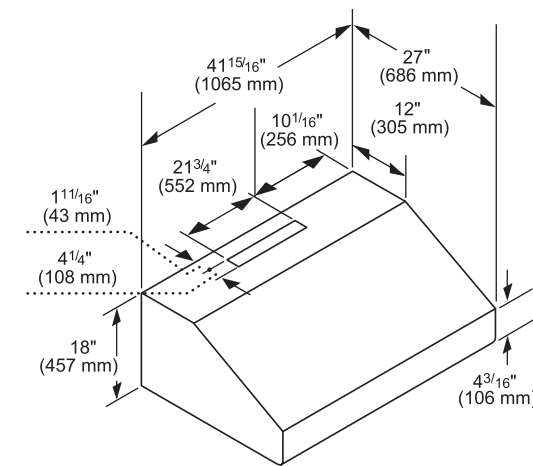

measurements in inches and mm

PH60GS 27-INCH DEPTH WALL HOOD (60-INCH WIDTH)

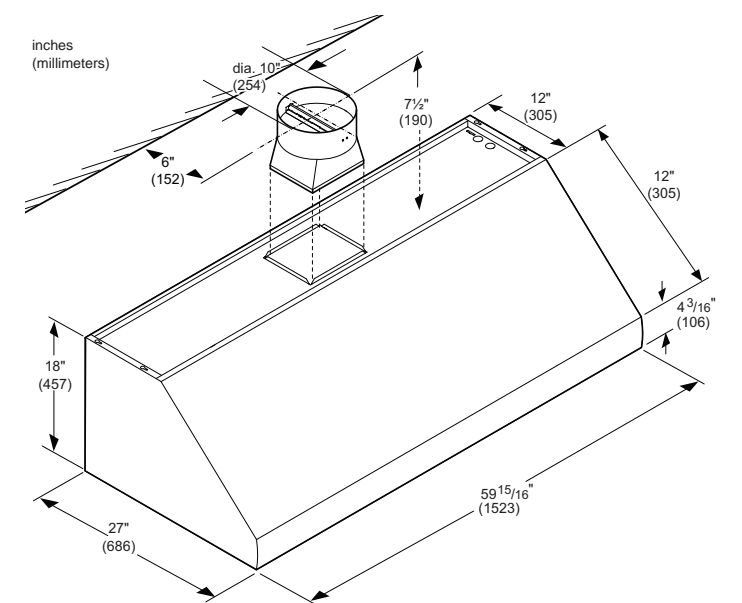

PH48GS 27-INCH DEPTH WALL HOOD (48-INCH WIDTH)

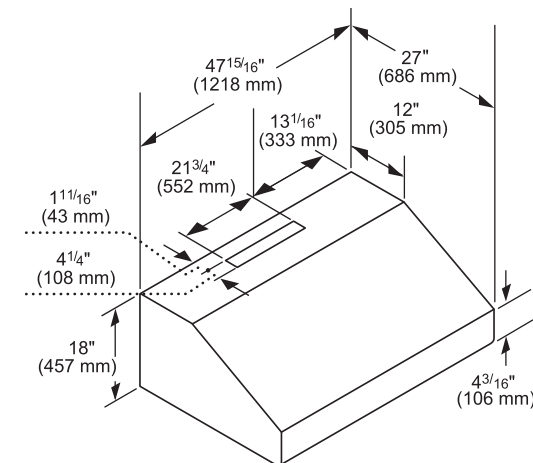

measurements in inches and mm

WALL HOODS INSTALLATION

PH30HS
24-INCH DEPTH WALL HOOD (30-INCH WIDTH)

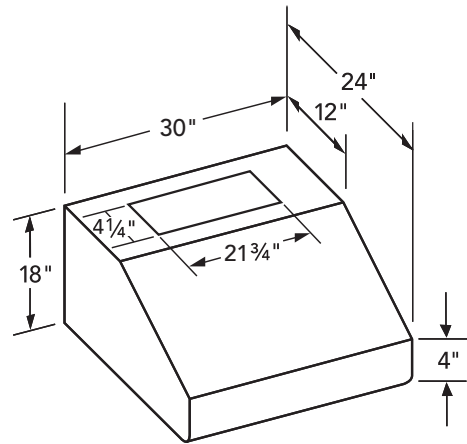

PH36HS
24-INCH DEPTH WALL HOOD (36-INCH WIDTH)

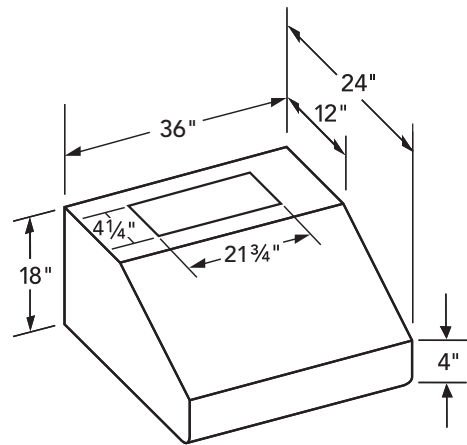

PH48HS
24-INCH DEPTH WALL HOOD (48-INCH WIDTH)

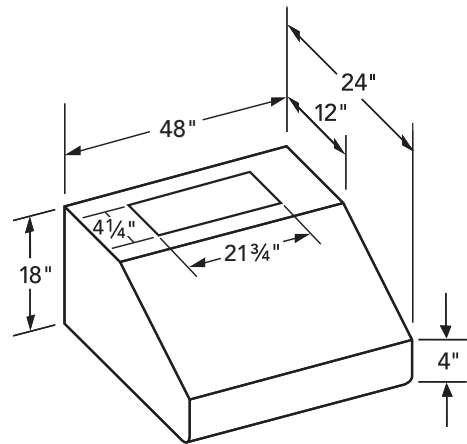

HPWB30FS
24-INCH DEPTH WALL HOOD WITH BLOWER (30-INCH WIDTH)

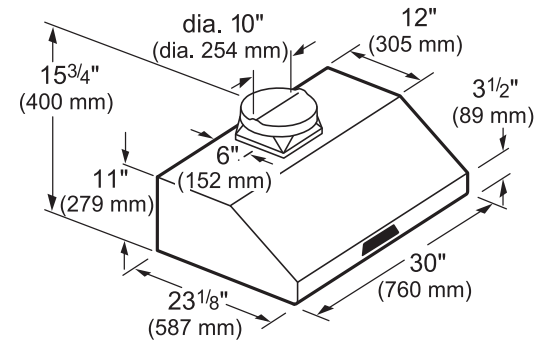

measurements in inches and mm

HPWB36FS
24-INCH DEPTH WALL HOOD WITH BLOWER (36-INCH WIDTH)

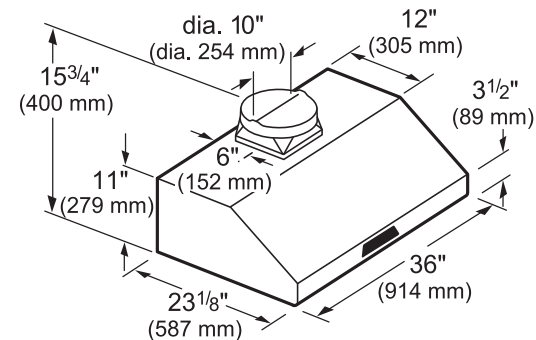

measurements in inches and mm

HPWB48FS
24-INCH DEPTH WALL HOOD WITH BLOWER (48-INCH WIDTH)

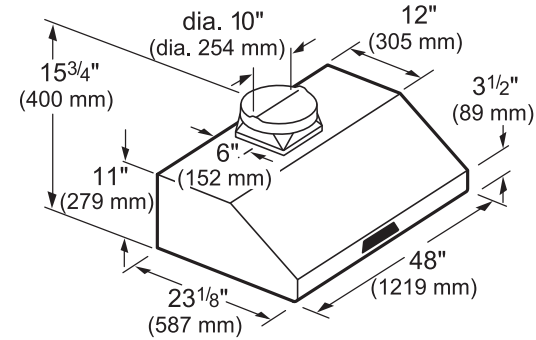

measurements in inches and mm

HMWN30FS
WALL HOOD (30-INCH WIDTH)

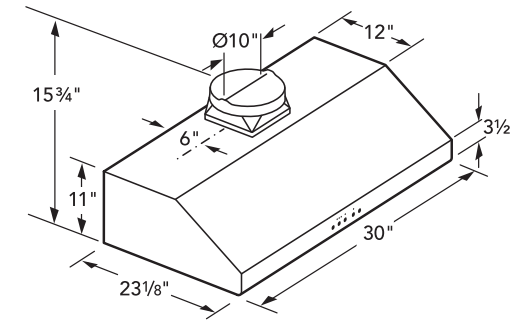

HMWN36FS
WALL HOOD (36-INCH WIDTH)

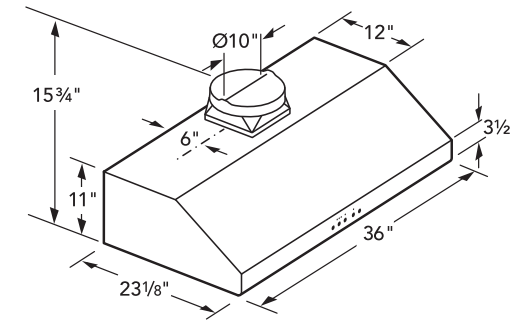

HMWN48FS
WALL HOOD (48-INCH WIDTH)

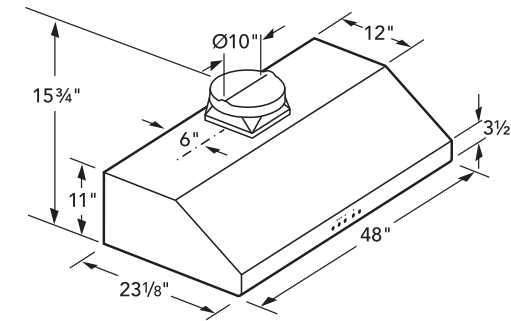

HMWB30FS
WALL HOOD WITH BLOWER (30-INCH WIDTH)

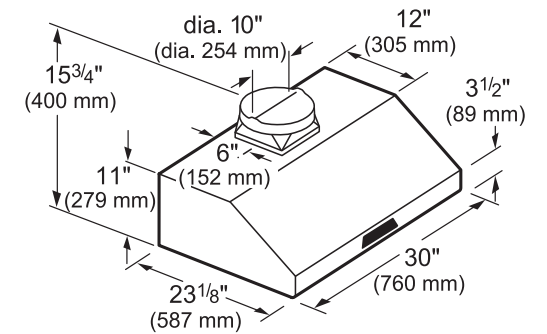

measurements in inches and mm

HMWB36FS
WALL HOOD WITH BLOWER (36-INCH WIDTH)

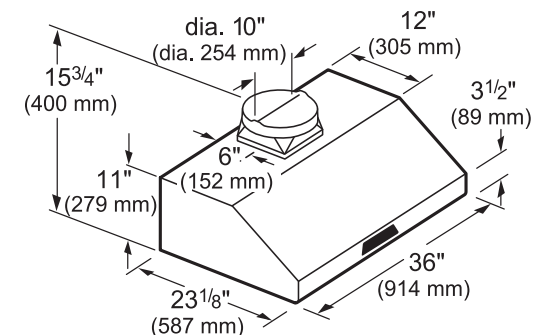

measurements in inches and mm

WALL HOODS INSTALLATION

VENTILATION

CHIMNEY WALL HOODS



Chimney Wall Hoods VENTILATION

Our Professional Series chimney style wall hoods impart a more traditional feel to the kitchen space while Masterpiece® Series impart a more contemporary feel. Each model is adjustable to suit a range of ceiling heights and includes conveniences such as dishwasher-safe filters and electronic controls. Halogen lighting brilliantly illuminates your cooking space for excellent visibility.

BAFFLE FILTERS

The stainless steel, commercial style baffle filters make high-grease cooking easy. They are dishwasher-safe for easy cleanup.

MESH FILTERS

Aluminum mesh filters with stainless steel frame maximize grease capture without affecting flow and feature a quick release latch for easy cleanup.

HALOGEN LIGHTS

Bright halogen lighting spotlights your best recipes.

ELECTRONIC TOUCH CONTROL

The sleek electronic touch control panel is easy-to-use and easy-to-clean.

TIME-TO-CLEAN-FILTER LIGHT

Easy cleanup: All Thermador ventilation filters are dishwasher-safe, and many hoods feature a built-in Time-to-Clean-Filter reminder light. (Except HMCB36FS, HMCB42FS)

DELAYED SHUT-OFF

For the greatest efficiency, our Masterpiece® ventilation models include delayed shut-off to tackle lingering odors. (Except HMCB36FS, HMCB42FS)



MODELS SHOWN: PCG366G PRO RANGETOP AND HMCN36FS CHIMNEY WALL HOOD. KITCHEN DESIGN BY: CHRISTY M. BOWEN & ROY FAUST, TWELVE STONES DESIGNS / NEW CREATIONS CUSTOM KITCHENS AND BATHS

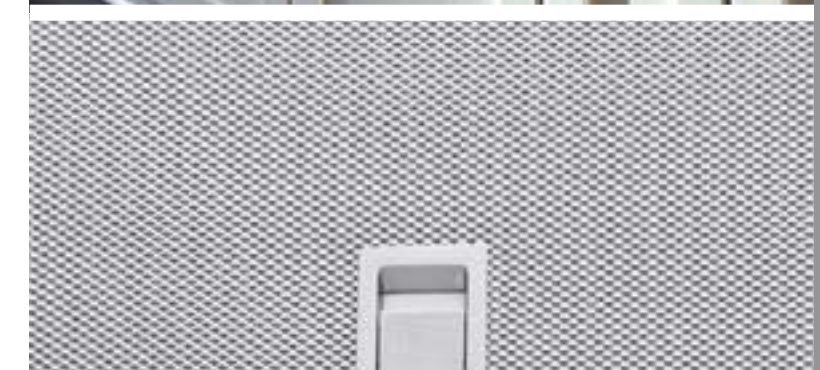

HPCN36NS

36-INCH CHIMNEY WALL HOOD

PROFESSIONAL SERIES



FEATURES & BENEFITS

- Three fan speeds
- Powerfully Quiet ventilation systems
- Dimmer lighting – for a soft lighting effect
- Commercial-Style Stainless Steel Baffle Filter
- Dishwasher safe grease collection trays are easily removed
- Auto function senses heat from the cooking surface and adjusts fan speeds
- Built-in 'Clean Filter' reminder light illuminates after 40 hours of operation
- Delayed shut-off tackles lingering odors for up to 10 minutes

ACCESSORIES (OPTIONAL)

25 ft. Blower Connector Cable - EXTNCB25

For use with the following Inline and Remote Blowers: VTR630P, VTR1030P, VTR1330P, VTI610P, VTI1010P

Roofplates

RFPLT600P - For use with 600 CFM Remote Blower VTR630P

RFPLT1000P - For use with 1000 CFM Remote Blower VTR1030P and 1300 CFM Blower VTR1330P

6" High Duct Cover	CHMHP366N
12" High Duct Cover	CHMHP3612N
18" - 35" High Duct Cover	CHMHP36TSN

GENERAL PROPERTIES	
Operating Mode	Ducted
Maximum CFM	Blower Sold Separately
Sones	N/A
Number of Speed Settings	3-Stage
Motor Location	Blower Sold Separately
Number of Lights	2
Bulb Type	40 W - G9 Base
Total Power of the Lamps (W)	40 W
Damper Included	Yes
Grease Filter Material	Washable Stainless Steel
Grease Filter Type	Commercial-Style Stainless Steel Baffle Filter

TECHNICAL DETAILS	
Watts (W)	N/A
Current (A)	15 A
Volts (V)	120 V
Frequency (Hz)	60 Hz
Plug Type	Fixed Connection, No Plug
Conduit Length	N/A

DIMENSIONS & WEIGHT	
Overall Appliance Dimensions (Width of Canopy Included) (HxWxD) (in)	18" x 35 15/16" x 24"
Height of The Chimney (in)	Duct Covers Sold Separately
Required Distance Above Cooktop / Range Cooking Surface	30" / 30"
Diameter of Air Duct (in) Top	10"
Net Weight (lbs)	70 lbs

ACCESSORIES (REQUIRED)	
Blower (Sold Separately)	

BLOWER OPTIONS	
Remote Blower (Mounted to Roof or External Wall)	VTR630P - 600 CFM
	VTR1030P - 1000 CFM
	VTR1330P - 1300 CFM
Inline Blower (Mounted Between Kitchen and External Wall)	VTI610P - 600 CFM
	VTI1010P - 1000 CFM
Integrated Blower (Mounted in Hood)	VTN1090R - 1000 CFM

WARRANTY	
Limited Warranty Parts and Labor	2 Year

HPCN48NS

48-INCH CHIMNEY WALL HOOD

PROFESSIONAL SERIES



FEATURES & BENEFITS

- Three fan speeds
- Powerfully Quiet ventilation systems
- Dimmer lighting – for a soft lighting effect
- Commercial-Style Stainless Steel Baffle Filter
- Dishwasher safe grease collection trays are easily removed
- Auto function senses heat from the cooking surface and adjusts fan speeds
- Built-in 'Clean Filter' reminder light illuminates after 40 hours of operation
- Delayed shut-off tackles lingering odors for up to 10 minutes

ACCESSORIES (OPTIONAL)

25 ft. Blower Connector Cable - EXTNCB25

For use with the following Inline and Remote Blowers: VTR630P, VTR1030P, VTR1330P, VTI610P, VTI1010P

Roofplates

RFPLT600P - For use with 600 CFM Remote Blower VTR630P

RFPLT1000P - For use with 1000 CFM Remote Blower VTR1030P and 1300 CFM Blower VTR1330P

6" High Duct Cover	CHMHP486N
12" High Duct Cover	CHMHP4812N
18" - 35" High Duct Cover	CHMHP48TSN

GENERAL PROPERTIES	
Operating Mode	Ducted
Maximum CFM	Blower Sold Separately
Sones	N/A
Number of Speed Settings	3-Stage
Motor Location	Blower Sold Separately
Number of Lights	4
Bulb Type	40 W - G9 Base
Total Power of the Lamps (W)	40 W
Damper Included	Yes
Grease Filter Material	Washable Stainless Steel
Grease Filter Type	Commercial-Style Stainless Steel Baffle Filter

TECHNICAL DETAILS	
Watts (W)	N/A
Current (A)	15 A
Volts (V)	120 V
Frequency (Hz)	60 Hz
Plug Type	Fixed Connection, No Plug
Conduit Length	N/A

DIMENSIONS & WEIGHT	
Overall Appliance Dimensions (Width of Canopy Included) (HxWxD) (in)	18" x 47 15/16" x 24"
Height of The Chimney (in)	Duct Covers Sold Separately
Required Distance Above Cooktop / Range Cooking Surface	30" / 30"
Diameter of Air Duct (in) Top	10"
Net Weight (lbs)	88 lbs

ACCESSORIES (REQUIRED)	
Blower (Sold Separately)	

BLOWER OPTIONS	
Remote Blower (Mounted to Roof or External Wall)	VTR630P - 600 CFM
	VTR1030P - 1000 CFM
	VTR1330P - 1300 CFM
Inline Blower (Mounted Between Kitchen and External Wall)	VTI610P - 600 CFM
	VTI1010P - 1000 CFM
Integrated Blower (Mounted in Hood)	VTN1090R - 1000 CFM

WARRANTY	
Limited Warranty Parts and Labor	2 Year

HPCB36NS

36-INCH CHIMNEY WALL HOOD WITH BLOWER

PROFESSIONAL SERIES



FEATURES & BENEFITS

- 1,000 CFM Integrated Blower included
- Three fan speeds
- Dimmer lighting – for a soft lighting effect
- Commercial-Style Stainless Steel Baffle Filter
- Filter systems are highly efficient at capturing grease
- Auto function senses heat from the cooking surface and adjusts fan speeds
- Built-in 'Clean Filter' reminder light illuminates after 40 hours of operation
- Delayed shut-off tackles lingering odors for up to 10 minutes

ACCESSORIES (OPTIONAL)

6" High Duct Cover	CHMHP366N
12" High Duct Cover	CHMHP3612N
18" - 35" High Duct Cover	CHMHP36TSN

GENERAL PROPERTIES	
Operating Mode	Ducted
Maximum CFM	1,000 CFM
Sones	12.0 HS / 4.0 WS
Number of Speed Settings	3-Stage
Motor Location	Integrated Motor In Hood Body
Number of Lights	2
Bulb Type	40 W - G9 Base
Total Power of the Lamps (W)	40 W
Damper Included	Yes
Grease Filter Material	Washable Stainless Steel
Grease Filter Type	Commercial-Style Stainless Steel Baffle Filter

TECHNICAL DETAILS	
Watts (W)	N/A
Current (A)	15 A
Volts (V)	120 V
Frequency (Hz)	60 Hz
Plug Type	Fixed Connection, No Plug
Conduit Length	N/A

DIMENSIONS & WEIGHT	
Overall Appliance Dimensions (Width of Canopy Included) (HxWxD) (in)	18" x 35 15/16" x 24"
Height of The Chimney (in)	Duct Covers Sold Separately
Required Distance Above Cooktop / Range Cooking Surface	30" / 30"
Diameter of Air Duct (in) Top	10"
Net Weight (lbs)	91 lbs

BLOWER OPTIONS	
Remote Blower (Mounted to Roof or External Wall)	N/A
	N/A
	N/A
Inline Blower (Mounted Between Kitchen and External Wall)	N/A
	N/A
Integrated Blower (Mounted in Hood)	N/A

WARRANTY	
Limited Warranty Parts and Labor	2 Year

HPCB48NS

48-INCH CHIMNEY WALL HOOD WITH BLOWER

PROFESSIONAL SERIES



FEATURES & BENEFITS

- 1,000 CFM Integrated Blower included
- Three fan speeds
- Dimmer lighting – for a soft lighting effect
- Commercial-Style Stainless Steel Baffle Filter
- Filter systems are highly efficient at capturing grease
- Auto function senses heat from the cooking surface and adjusts fan speeds
- Built-in 'Clean Filter' reminder light illuminates after 40 hours of operation
- Delayed shut-off tackles lingering odors for up to 10 minutes

ACCESSORIES (OPTIONAL)

6" High Duct Cover	CHMHP486N
12" High Duct Cover	CHMHP4812N
18" - 35" High Duct Cover	CHMHP48TSN

GENERAL PROPERTIES	
Operating Mode	Ducted
Maximum CFM	1,000 CFM
Sones	10.5 HS / 2.5 WS
Number of Speed Settings	3-Stage
Motor Location	Integrated Motor In Hood Body
Number of Lights	4
Bulb Type	40 W - G9 Base
Total Power of the Lamps (W)	40 W
Damper Included	Yes
Grease Filter Material	Washable Stainless Steel
Grease Filter Type	Commercial-Style Stainless Steel Baffle Filter

TECHNICAL DETAILS	
Watts (W)	N/A
Current (A)	15 A
Volts (V)	120 V
Frequency (Hz)	60 Hz
Plug Type	Fixed Connection, No Plug
Conduit Length	N/A

DIMENSIONS & WEIGHT	
Overall Appliance Dimensions (Width of Canopy Included) (HxWxD) (in)	18" x 47 15/16" x 24"
Height of The Chimney (in)	Duct Covers Sold Separately
Required Distance Above Cooktop / Range Cooking Surface	30" / 30"
Diameter of Air Duct (in) Top	10"
Net Weight (lbs)	110 lbs

BLOWER OPTIONS	
Remote Blower (Mounted to Roof or External Wall)	N/A
	N/A
	N/A
Inline Blower (Mounted Between Kitchen and External Wall)	N/A
	N/A
Integrated Blower (Mounted in Hood)	N/A

WARRANTY	
Limited Warranty Parts and Labor	2 Year

HMCN36FS

36-INCH CHIMNEY WALL HOOD

MASTERPIECE® SERIES



FEATURES & BENEFITS

- Three fan speeds plus 10 minute high-power operation mode
- Delayed shut-off tackles lingering odors for up to 10 minutes
- Built-in 'Clean Filter' reminder light illuminates after 40 hours of operation
- Dimmer lighting—for those hours after a late meal
- Dishwasher-safe stainless-frame mesh filters

ACCESSORIES (OPTIONAL)

Roofplates

RFPLT600P - For use with 600 CFM Remote Blower VTR630P

RFPLT1000P - For use with 1000 CFM Remote Blower VTR1030P and 1300 CFM Blower VTR1330P

Stainless Steel Chimney Hood Extension - CHIMXHMC

For up to 11-foot ceiling applications. Extension replaces upper section of standard chimney extension. May require fabrication to reduce height.



GENERAL PROPERTIES	
Operating Mode	Ducted
Maximum CFM	Blower Sold Separately
Sones	N/A
Number of Speed Settings	3-Stage
Motor Location	Blower Sold Separately
Number of Lights	3
Bulb Type	20 W - G4 Base
Total Power of the Lamps (W)	20 W
Damper Included	No
Grease Filter Material	Washable Synthetic
Grease Filter Type	Multilayer Cassette
TECHNICAL DETAILS	
Watts (W)	60 W
Current (A)	15 A
Volts (V)	110 V
Frequency (Hz)	60 Hz
Plug Type	120V-3 Prong
Conduit Length	N/A
DIMENSIONS & WEIGHT	
Overall Appliance Dimensions (Width of Canopy Included) (HxWxD) (in)	31" - 35" x 35 1/2" x 21 1/2"
Height of The Chimney (in)	21 1/2" - 25 1/2"
Accommodates Ceiling Heights	8 ft. 2 in. - 9 ft.
Required Distance Above Cooktop / Range Cooking Surface	30" / 30"
Diameter of Air Duct (in) Top	8"
Net Weight (lbs)	41 lbs
ACCESSORIES (REQUIRED)	
Blower (Sold Separately)	
BLOWER OPTIONS	
Remote Blower (Mounted to Roof or External Wall)	VTR630P - 600 CFM
	VTR1030P - 1000 CFM
	VTR1330P - 1300 CFM
Inline Blower (Mounted Between Kitchen and External Wall)	VTI610P - 600 CFM
	VTI1010P - 1000 CFM
Integrated Blower (Mounted in Hood)	VTN1080N - 1000 CFM
WARRANTY	
Limited Warranty Parts and Labor	2 Year

HMCN42FS

42-INCH CHIMNEY WALL HOOD

MASTERPIECE® SERIES



FEATURES & BENEFITS

- Three fan speeds plus 10 minute high-power operation mode
- Delayed shut-off tackles lingering odors for up to 10 minutes
- Built-in 'Clean Filter' reminder light illuminates after 40 hours of operation
- Dimmer lighting—for those hours after a late meal
- Dishwasher-safe stainless-frame mesh filters

ACCESSORIES (OPTIONAL)

Roofplates

RFPLT600P - For use with 600 CFM Remote Blower VTR630P

RFPLT1000P - For use with 1000 CFM Remote Blower VTR1030P and 1300 CFM Blower VTR1330P

Stainless Steel Chimney Hood Extension - CHIMXHMC

For up to 11-foot ceiling applications. Extension replaces upper section of standard chimney extension. May require fabrication to reduce height.



GENERAL PROPERTIES	
Operating Mode	Ducted
Maximum CFM	Blower Sold Separately
Sones	N/A
Number of Speed Settings	3-Stage
Motor Location	Blower Sold Separately
Number of Lights	3
Bulb Type	20 W - G4 Base
Total Power of the Lamps (W)	20 W
Damper Included	No
Grease Filter Material	Washable Synthetic
Grease Filter Type	Multilayer Cassette
TECHNICAL DETAILS	
Watts (W)	60 W
Current (A)	15 A
Volts (V)	110 V
Frequency (Hz)	60 Hz
Plug Type	120V-3 Prong
Conduit Length	51"
DIMENSIONS & WEIGHT	
Overall Appliance Dimensions (Width of Canopy Included) (HxWxD) (in)	31" - 35" x 41 1/2" x 21 1/2"
Height of The Chimney (in)	21 1/2" - 25 1/2"
Accommodates Ceiling Heights	8 ft. 2 in. - 9 ft.
Required Distance Above Cooktop / Range Cooking Surface	30" / 30"
Diameter of Air Duct (in) Top	8"
Net Weight (lbs)	44 lbs
ACCESSORIES (REQUIRED)	
Blower (Sold Separately)	
BLOWER OPTIONS	
Remote Blower (Mounted to Roof or External Wall)	VTR630P - 600 CFM
	VTR1030P - 1000 CFM
	VTR1330P - 1300 CFM
Inline Blower (Mounted Between Kitchen and External Wall)	VTI610P - 600 CFM
	VTI1010P - 1000 CFM
Integrated Blower (Mounted in Hood)	VTN1080N - 1000 CFM
WARRANTY	
Limited Warranty Parts and Labor	2 Year

HMCB36FS

36-INCH CHIMNEY WALL HOOD WITH BLOWER

MASTERPIECE® SERIES



FEATURES & BENEFITS

- 600 CFM Integrated Blower included
- Three fan speeds plus 10 minute high-power operation mode
- Dishwasher-safe stainless-frame mesh filters
- Filter systems are highly efficient at capturing grease
- Powerfully Quiet® ventilation systems

ACCESSORIES (OPTIONAL)

Stainless Steel Chimney Hood Extension - CHIMXHMC
For up to 11-foot ceiling applications. Extension replaces upper section of standard chimney extension. May require fabrication to reduce height.

GENERAL PROPERTIES	
Operating Mode	Ducted
Maximum CFM	600 CFM
Sones	N/A
Number of Speed Settings	3-Stage
Motor Location	Integrated Motor In Hood Body
Number of Lights	3
Bulb Type	20 W - G4 Base
Total Power of the Lamps (W)	20 W
Damper Included	Yes
Grease Filter Material	Washable Synthetic
Grease Filter Type	Multilayer Cassette
TECHNICAL DETAILS	
Watts (W)	590 W
Current (A)	15 A
Volts (V)	110 V
Frequency (Hz)	60 Hz
Plug Type	120V-3 Prong
Conduit Length	51"
DIMENSIONS & WEIGHT	
Overall Appliance Dimensions (Width of Canopy Included) (HxWxD) (in)	31" - 35" / x 35 1/2" x 21 1/2"
Height of The Chimney (in)	21 1/2" - 25 1/2"
Accommodates Ceiling Heights	8 ft. 2 in. - 9 ft.
Required Distance Above Cooktop / Range Cooking Surface	30" / 30"
Diameter of Air Duct (in) Top	6"
Net Weight (lbs)	48 lbs
BLOWER OPTIONS	
Remote Blower (Mounted to Roof or External Wall)	N/A
	N/A
	N/A
Inline Blower (Mounted Between Kitchen and External Wall)	N/A
	N/A
Integrated Blower (Mounted in Hood)	N/A
WARRANTY	
Limited Warranty Parts and Labor	2 Year

HMCB42FS

42-INCH CHIMNEY WALL HOOD WITH BLOWER

MASTERPIECE® SERIES



FEATURES & BENEFITS

- 600 CFM Integrated Blower included
- Three fan speeds plus 10 minute high-power operation mode
- Dishwasher-safe stainless-frame mesh filters
- Filter systems are highly efficient at capturing grease
- Powerfully Quiet® ventilation systems

ACCESSORIES (OPTIONAL)

Stainless Steel Chimney Hood Extension - CHIMXHMC
For up to 11-foot ceiling applications. Extension replaces upper section of standard chimney extension. May require fabrication to reduce height.

GENERAL PROPERTIES	
Operating Mode	Ducted
Maximum CFM	600 CFM
Sones	N/A
Number of Speed Settings	3-Stage
Motor Location	Integrated Motor In Hood Body
Number of Lights	3
Bulb Type	20 W - G4 Base
Total Power of the Lamps (W)	20 W
Damper Included	Yes
Grease Filter Material	Washable Synthetic
Grease Filter Type	Multilayer Cassette
TECHNICAL DETAILS	
Watts (W)	590 W
Current (A)	15 A
Volts (V)	110 V
Frequency (Hz)	60 Hz
Plug Type	120V-3 Prong
Conduit Length	51"
DIMENSIONS & WEIGHT	
Overall Appliance Dimensions (Width of Canopy Included) (HxWxD) (in)	31" - 35" / x 41 1/2" x 21 1/2"
Height of The Chimney (in)	21 1/2" - 25 1/2"
Accommodates Ceiling Heights	8 ft. 2 in. - 9 ft.
Required Distance Above Cooktop / Range Cooking Surface	30" / 30"
Diameter of Air Duct (in) Top	6"
Net Weight (lbs)	57 lbs
BLOWER OPTIONS	
Remote Blower (Mounted to Roof or External Wall)	N/A
	N/A
	N/A
Inline Blower (Mounted Between Kitchen and External Wall)	N/A
	N/A
Integrated Blower (Mounted in Hood)	N/A
WARRANTY	
Limited Warranty Parts and Labor	2 Year

HDDW36FS

36-INCH CHIMNEY WALL DRAWER HOOD

MASTERPIECE® SERIES



FEATURES & BENEFITS

- ★ - Unique sliding stainless canopy can be pushed back against the wall for increased head room
- ★ - 45% increase in capture area when hood is extended
- 600 CFM Integrated Blower included
- Three fan speeds plus 10 minute high-power operation mode
- Built-in 'Clean Filter' reminder light illuminates after 40 hours of operation
- Dimmer lighting—for those hours after a late meal
- Dishwasher-safe stainless-frame mesh filters

ACCESSORIES (OPTIONAL)

Stainless Steel Chimney Hood Extension - CHIMXHDD

For up to 11-foot ceiling applications. Extension replaces upper section of standard chimney extension. May require fabrication to reduce height.

GENERAL PROPERTIES	
Operating Mode	Ducted
Maximum CFM	600 CFM
Sones	N/A
Number of Speed Settings	3-Stage
Motor Location	Integrated Motor In Hood Body
Number of Lights	4
Bulb Type	20 W - G4 Base
Total Power of the Lamps (W)	20 W
Damper Included	Yes
Grease Filter Material	Washable Synthetic
Grease Filter Type	Multilayer Cassette
TECHNICAL DETAILS	
Watts (W)	610 W
Current (A)	15 A
Volts (V)	120 V
Frequency (Hz)	60 Hz
Plug Type	120V-3 Prong
Conduit Length	51"
DIMENSIONS & WEIGHT	
Overall Appliance Dimensions (Width of Canopy Included) (HxWxD) (in)	26 3/4" - 42 1/2" x 35 1/2" x 17"
Height of The Chimney (in)	23 7/8" - 39 5/8"
Accommodates Ceiling Heights	7 ft. 9 in. - 9 ft. 6 in.
Required Distance Above Cooktop / Range Cooking Surface	30" / 30"
Diameter of Air Duct (in) Top	6"
Net Weight (lbs)	64 lbs
BLOWER OPTIONS	
Remote Blower (Mounted to Roof or External Wall)	N/A
	N/A
	N/A
Inline Blower (Mounted Between Kitchen and External Wall)	N/A
	N/A
Integrated Blower (Mounted in Hood)	N/A
WARRANTY	
Limited Warranty Parts and Labor	2 Year

MODEL OPTIONS

Thermador Chimney Wall Hoods feature sleek styling and numerous convenience functions. Chimney Wall Hoods are available in 36-inch, 42-inch and 48-inch widths and are adjustable to suit a range of ceiling heights. All stainless steel or stainless steel with glass designs are available. Be sure to reference the correct model information in this design guide.

ELECTRICAL SPECIFICATIONS

Be sure your Thermador Chimney Wall Hood is properly installed and grounded by a qualified technician. Installation, electrical connections and grounding must comply with all applicable local codes.

If possible, site the earthed socket directly behind the chimney paneling. The grounded socket should be connected via its own circuit. If the grounded socket is no longer accessible following installation of the hood, ensure that there is a permanently installed disconnect.

MODEL	REQUIRED CIRCUIT BREAKER
	120V AC, 60 Hz
HPCN36NS	15 A
HPCN48NS	15 A
HPCB36NS	15 A
HPCB48NS	15 A
HMCN36FS	15 A
HMCN42FS	15 A
HMCB36FS	15 A
HMCB42FS	15 A
HDDW36FS	15 A

CHIMNEY WALL HOODS

PLANNING INFORMATION

INSTALLATION CONSIDERATIONS

The information in this design guide provides key features, product dimensions, cutouts and installation specifications. Before installing a Thermador Chimney Wall Hood, be sure to verify the cutout dimensions and electrical connections. Also, always consult with the installation manual packed with the product for complete details before installing.

INSTALLATION OPTIONS

Thermador Chimney Wall Hoods may be installed above a Thermador Range or Cooktop to create a convenient cooking center. Refer to the ventilation selection guide for compatibility.

Hood installation height above a range or cooktop can vary. To obtain the necessary installation height above a Thermador Range or Cooktop, consult the appliance's installation manual. An accessory Hood Extension can be used to fill the space between the hood and ceiling.

Thermador Wall Hoods can be mounted on a wall or suspended from a cabinet. The cabinet must be structurally joined to the wall studs to support the weight of this hood.

CHIMNEY WALL HOODS INSTALLATION

HPCN36NS
36-INCH CHIMNEY WALL HOOD

HPCB36NS
36-INCH CHIMNEY WALL HOOD WITH BLOWER

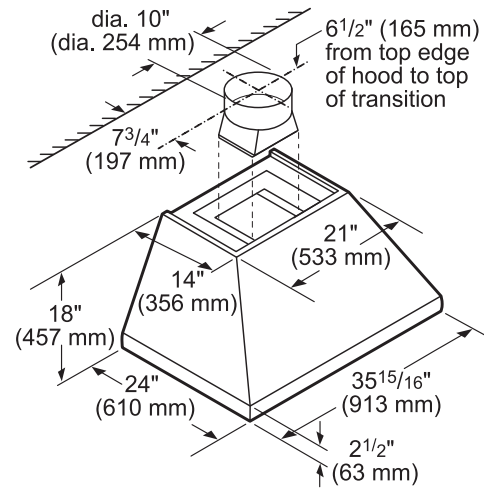

HPCN48NS
48-INCH CHIMNEY WALL HOOD

HPCB48NS
48-INCH CHIMNEY WALL HOOD WITH BLOWER

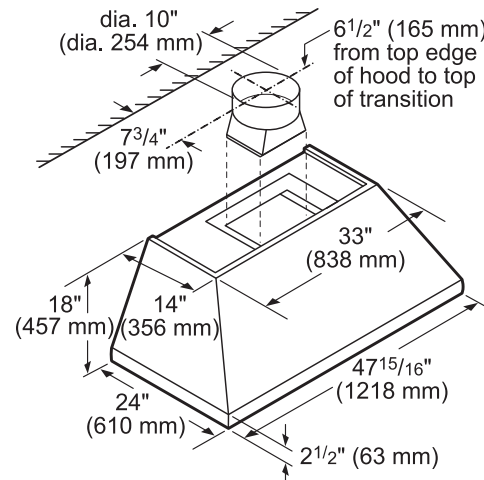

HMCN36FS
36-INCH CHIMNEY WALL HOOD

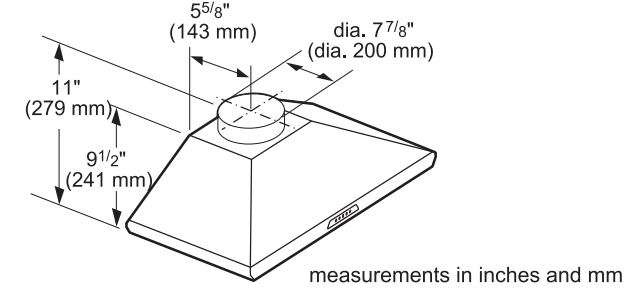
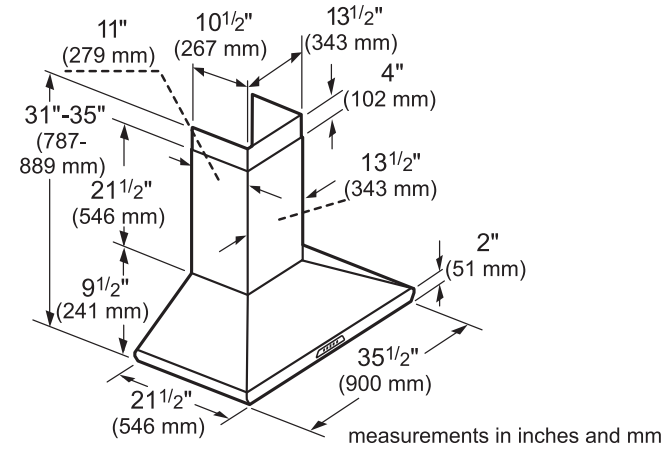

HMCB36FS
36-INCH CHIMNEY WALL HOOD WITH BLOWER

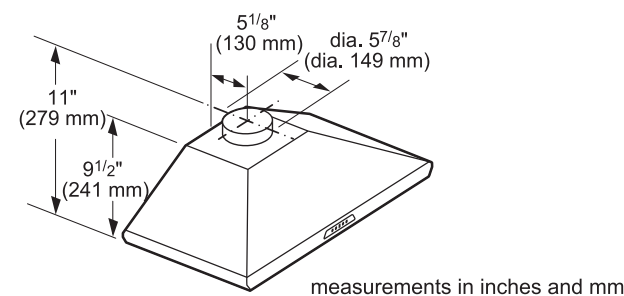
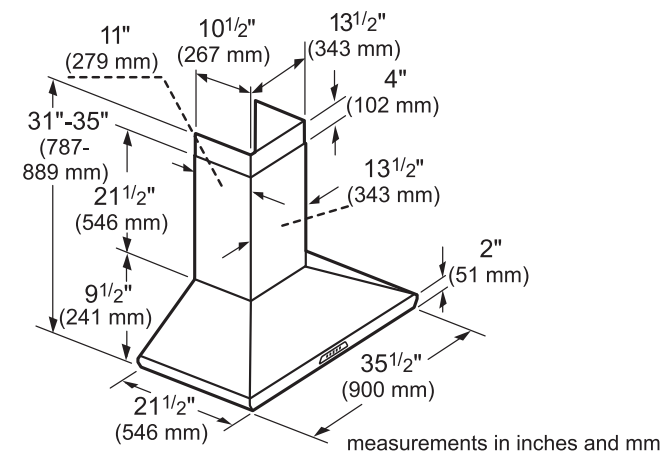

HMCN42FS
42-INCH CHIMNEY WALL HOOD

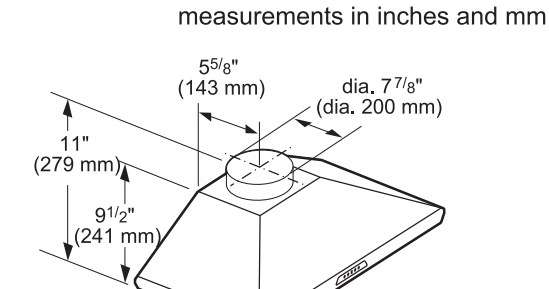
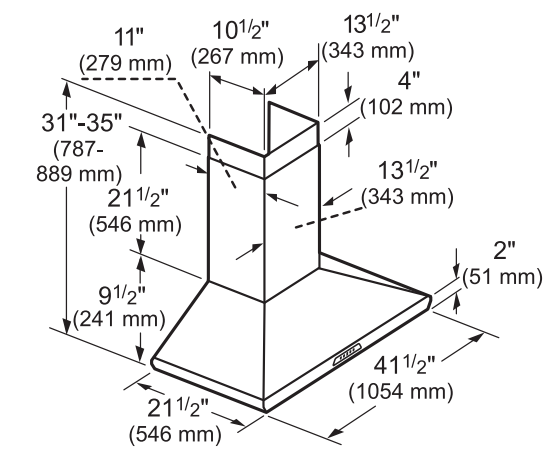

HDDW36FS
36-INCH CHIMNEY WALL DRAWER HOOD

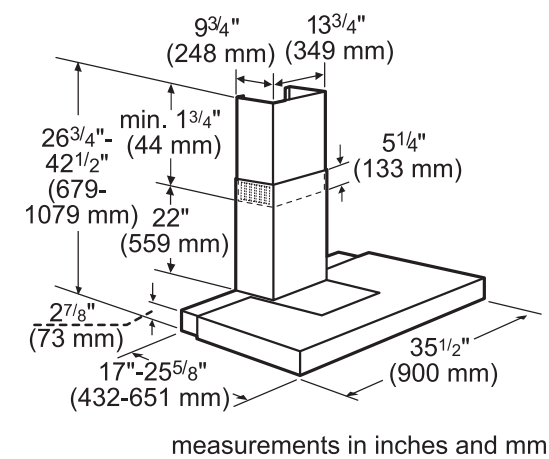

INSTALLATION NOTE: This product ships with two transport brackets to hold the movable canopy in place during shipping and installation. After installation, be sure to remove the brackets to operate the sliding drawer canopy.

CHIMNEY WALL HOODS INSTALLATION

HMCB42FS
42-INCH CHIMNEY WALL HOOD WITH BLOWER

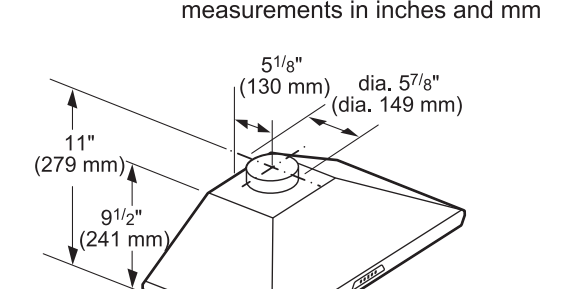
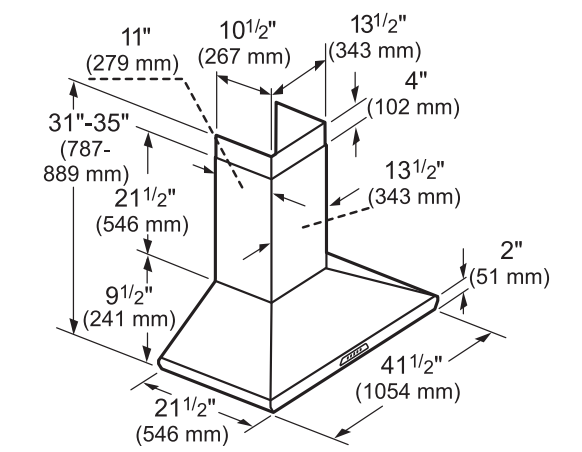

VENTILATION

ISLAND HOODS



Island Hoods VENTILATION

Thermador® Island Hoods make an artful design statement in your kitchen. With excellent efficiency in drawing away smoke, moisture and heat, the adjustable chimney height is perfect over island cooktop or range installations. Dishwasher-safe filters make cleanup easy.

EXTERIOR CONTROLS

Easy-to-clean, easy-to-use push-button controls put accuracy at your fingertips.

POWERFULLY QUIET® OPERATION

Steam, smoke and odors are no problem for Thermador ducted ventilation systems.

TIME-TO-CLEAN-FILTER LIGHT

Easy cleanup: All Thermador ventilation filters are dishwasher-safe, and many hoods feature a built-in Time-to-Clean-Filter reminder light.

DISHWASHER-SAFE FILTERS

Dishwasher-safe aluminum filters for easy-clean maintenance.

DELAYED SHUT-OFF

For the greatest efficiency, our Professional and Masterpiece® ventilation models include delayed shut-off to tackle lingering odors.

HALOGEN LIGHTS

Bright halogen lighting spotlights your best recipes.



HPIN42HS

42-INCH LOW PROFILE ISLAND HOOD

PROFESSIONAL SERIES



FEATURES & BENEFITS

- Three fan speeds
- Built-in 'Clean Filter' reminder light illuminates after 40 hours of operation
- Delayed shut-off tackles lingering odors for up to 10 minutes
- Dishwasher-safe frameless filters with stainless steel covers
- Filter systems are highly efficient at capturing grease

ACCESSORIES (OPTIONAL)

25 ft. Blower Connector Cable - EXTNCB25

For use with the following Inline and Remote Blowers: VTR630P, VTR1030P, VTR1330P, VTI610P, VTI1010P

Roofplates

RFPLT600P - For use with 600 CFM Remote Blower VTR630P

RFPLT1000P - For use with 1000 CFM Remote Blower VTR1030P and 1300 CFM Blower VTR1330P

GENERAL PROPERTIES	
Operating Mode	Ducted
Maximum CFM	Blower Sold Separately
Number of Speed Settings	3-Stage
Motor Location	N/A
Number Of Lights	4
Bulb Type	20 W - G4 Base
Total Power Of The Lamps (W)	80 W
Damper Included	Yes
Grease Filter Material	Washable Stainless Steel
Grease Filter Type	Multilayer Cassette

TECHNICAL DETAILS	
Watts (W)	80 W
Current (A)	10 A
Volts (V)	120 V
Frequency (Hz)	60 Hz
Plug Type	120V-3 Prong
Power Cord Length	51 2/16"

DIMENSIONS & WEIGHT	
Overall Appliance Dimensions (Width Of Canopy Included) (HxWxD) (in)	30 3/8" - 41 3/8" / x 41 1/3" x 27 1/2"
Height Of The Chimney (in)	28 3/8" - 39 7/16"
Minimum Ceiling Height Required	97 3/16"
Required Distance Above Cooktop / Range Cooking Surface	30" / 30"
Diameter of Air Duct (in) Top	6"
Net Weight (lbs)	87 lbs

ACCESSORIES (REQUIRED)	
Blower (Sold Separately)	

BLOWER OPTIONS	
Remote Blowers (Mounted to Roof or External Wall)	VTR630P - 600 CFM
	VTR1030P - 1000 CFM
	VTR1330P - 1300 CFM
Inline Blowers (Mounted Between Kitchen and External Wall)	VTI610P - 600 CFM
	VTI1010P - 1000 CFM

WARRANTY	
Limited Warranty Parts And Labor	2 Year

HPIN48HS

48-INCH LOW PROFILE ISLAND HOOD

PROFESSIONAL SERIES



FEATURES & BENEFITS

- Three fan speeds
- Built-in 'Clean Filter' reminder light illuminates after 40 hours of operation
- Delayed shut-off tackles lingering odors for up to 10 minutes
- Dishwasher-safe frameless filters with stainless steel covers
- Filter systems are highly efficient at capturing grease

ACCESSORIES (OPTIONAL)

25 ft. Blower Connector Cable - EXTNCB25

For use with the following Inline and Remote Blowers: VTR630P, VTR1030P, VTR1330P, VTI610P, VTI1010P

Roofplates

RFPLT600P - For use with 600 CFM Remote Blower VTR630P

RFPLT1000P - For use with 1000 CFM Remote Blower VTR1030P and 1300 CFM Blower VTR1330P

GENERAL PROPERTIES	
Operating Mode	Ducted
Maximum CFM	Blower Sold Separately
Number of Speed Settings	3-Stage
Motor Location	N/A
Number Of Lights	4
Bulb Type	20 W - G4 Base
Total Power Of The Lamps (W)	80 W
Damper Included	Yes
Grease Filter Material	Washable Stainless Steel
Grease Filter Type	Multilayer Cassette

TECHNICAL DETAILS	
Watts (W)	80 W
Current (A)	10 A
Volts (V)	120 V
Frequency (Hz)	60 Hz
Plug Type	120V-3 Prong
Power Cord Length	51 2/16"

DIMENSIONS & WEIGHT	
Overall Appliance Dimensions (Width Of Canopy Included) (HxWxD) (in)	30 3/8" - 41 3/8" / x 47 1/4" x 27 1/2"
Height Of The Chimney (in)	28 3/8" - 39 7/16"
Minimum Ceiling Height Required	97 3/16"
Required Distance Above Cooktop / Range Cooking Surface	30" / 30"
Diameter of Air Duct (in) Top	6"
Net Weight (lbs)	101 lbs

ACCESSORIES (REQUIRED)	
Blower (Sold Separately)	

BLOWER OPTIONS	
Remote Blowers (Mounted to Roof or External Wall)	VTR630P - 600 CFM
	VTR1030P - 1000 CFM
	VTR1330P - 1300 CFM
Inline Blowers (Mounted Between Kitchen and External Wall)	VTI610P - 600 CFM
	VTI1010P - 1000 CFM

WARRANTY	
Limited Warranty Parts And Labor	2 Year

HPIB42HS

42-INCH LOW PROFILE ISLAND HOOD WITH BLOWER

MASTERPIECE® SERIES



FEATURES & BENEFITS

- 600 CFM Integrated Blower included
- Recirculation possible with kit RECIRISL
- Three fan speeds
- Built-in 'Clean Filter' reminder light illuminates after 40 hours of operation
- Delayed shut-off tackles lingering odors for up to 10 minutes

ACCESSORIES (OPTIONAL)

- Recirculation Kit
- RECIRISL - For use with 600 CFM Blowers Only
- Replacement Charcoal Filters
- CHFILISL - For use with Recirculation Kit RECIRISL

GENERAL PROPERTIES	
Operating Mode	Convertible: Ducted / Recirculating
Maximum CFM	600 CFM
Number of Speed Settings	3-Stage
Motor Location	Integrated Motor in Hood Chimney
Number Of Lights	4
Bulb Type	20 W - G4 Base
Total Power Of The Lamps (W)	80 W
Damper Included	Yes
Grease Filter Material	Washable Stainless Steel
Grease Filter Type	Multilayer Cassette
TECHNICAL DETAILS	
Watts (W)	640 W
Current (A)	10 A
Volts (V)	120 V
Frequency (Hz)	60 Hz
Plug Type	120V-3 Prong
Power Cord Length	51 2/16"
DIMENSIONS & WEIGHT	
Overall Appliance Dimensions (Width Of Canopy Included) (HxWxD) (in)	30 3/8" - 41 3/8" / x 41 1/3" x 27 1/2"
Height Of The Chimney (in)	28 3/8" - 39 7/16"
Minimum Ceiling Height Required	97 3/16"
Required Distance Above Cooktop / Range Cooking Surface	30" / 30"
Diameter of Air Duct (in) Top	6"
Net Weight (lbs)	96 lbs
BLOWER OPTIONS	
Remote Blowers (Mounted to Roof or External Wall)	N/A
	N/A
	N/A
Inline Blowers (Mounted Between Kitchen and External Wall)	N/A
	N/A
WARRANTY	
Limited Warranty Parts And Labor	2 Year

HPIB48HS

48-INCH LOW PROFILE ISLAND HOOD WITH BLOWER

MASTERPIECE® SERIES



FEATURES & BENEFITS

- 600 CFM Integrated Blower included
- Recirculation possible with kit RECIRISL
- Three fan speeds
- Built-in 'Clean Filter' reminder light illuminates after 40 hours of operation
- Delayed shut-off tackles lingering odors for up to 10 minutes

ACCESSORIES (OPTIONAL)

- Recirculation Kit
- RECIRISL - For use with 600 CFM Blowers Only
- Replacement Charcoal Filters
- CHFILISL - For use with Recirculation Kit RECIRISL

GENERAL PROPERTIES	
Operating Mode	Convertible: Ducted / Recirculating
Maximum CFM	600 CFM
Number of Speed Settings	3-Stage
Motor Location	Integrated Motor in Hood Chimney
Number Of Lights	4
Bulb Type	20 W - G4 Base
Total Power Of The Lamps (W)	80 W
Damper Included	Yes
Grease Filter Material	Washable Stainless Steel
Grease Filter Type	Multilayer Cassette
TECHNICAL DETAILS	
Watts (W)	640 W
Current (A)	10 A
Volts (V)	120 V
Frequency (Hz)	60 Hz
Plug Type	120V-3 Prong
Power Cord Length	51 2/16"
DIMENSIONS & WEIGHT	
Overall Appliance Dimensions (Width Of Canopy Included) (HxWxD) (in)	30 3/8" - 41 3/8" / x 47 1/4" x 27 1/2"
Height Of The Chimney (in)	28 3/8" - 39 7/16"
Minimum Ceiling Height Required	97 3/16"
Required Distance Above Cooktop / Range Cooking Surface	30" / 30"
Diameter of Air Duct (in) Top	6"
Net Weight (lbs)	101 lbs
BLOWER OPTIONS	
Remote Blowers (Mounted to Roof or External Wall)	N/A
	N/A
	N/A
Inline Blowers (Mounted Between Kitchen and External Wall)	N/A
	N/A
WARRANTY	
Limited Warranty Parts And Labor	2 Year

HMIB40HS

40-INCH GLASS ISLAND HOOD WITH BLOWER

MASTERPIECE® SERIES



FEATURES & BENEFITS

- 600 CFM Integrated Blower included
- An ideal solution for island cooktop installations
- Four fan speeds including one intensive level
- Built-in 'Clean Filter' reminder light illuminates after 40 hours of operation
- Delayed shut-off tackles lingering odors for up to 10 minutes

ACCESSORIES (OPTIONAL)

- Recirculation Kit
- RECIRISL - For use with 600 CFM Blowers Only
- Replacement Charcoal Filters
- CHFILISL - For use with Recirculation Kit RECIRISL

GENERAL PROPERTIES	
Operating Mode	Convertible: Ducted / Recirculating
Maximum CFM	600 CFM
Number of Speed Settings	3-Stage
Motor Location	Integrated Motor in Hood Chimney
Number Of Lights	4
Bulb Type	20 W - G4 Base
Total Power Of The Lamps (W)	80 W
Damper Included	Yes
Grease Filter Material	Washable Synthetic
Grease Filter Type	Multilayer Cassette
TECHNICAL DETAILS	
Watts (W)	530 W
Current (A)	10 A
Volts (V)	120 V
Frequency (Hz)	60 Hz
Plug Type	120V-3 Prong
Power Cord Length	51 2/16"
DIMENSIONS & WEIGHT	
Overall Appliance Dimensions (Width Of Canopy Included) (HxWxD) (in)	30 3/8" - 41 3/8" / x 39 5/16" x 27 1/2"
Height Of The Chimney (in)	28 3/8" - 39 7/16"
Minimum Ceiling Height Required	97 3/16"
Required Distance Above Cooktop / Range Cooking Surface	30" / 30"
Diameter of Air Duct (in) Top	6"
Net Weight (lbs)	87 lbs
BLOWER OPTIONS	
Remote Blowers (Mounted to Roof or External Wall)	N/A
	N/A
	N/A
Inline Blowers (Mounted Between Kitchen and External Wall)	N/A
	N/A
WARRANTY	
Limited Warranty Parts And Labor	2 Year

MODEL OPTIONS

Thermador Island Hoods are available in 40-inch, 42-inch and 48-inch widths and feature a stainless steel design and the 40-inch has an elegant glass canopy. All of our island hoods are adjustable to suit ceiling heights of up to 9'.

ELECTRICAL SPECIFICATIONS

Be sure your Thermador Island Hood is properly installed and grounded by a qualified technician. Installation, electrical connections and grounding must comply with all applicable local codes.

MODEL	REQUIRED CIRCUIT BREAKER
	120V AC, 60 Hz
HPIN42HS	10 A
HPIN48HS	10 A
HPIB42HS	10 A
HPIB48HS	10 A
HMIB40HS	10 A

ISLAND HOODS

PLANNING INFORMATION

INSTALLATION CONSIDERATIONS

The information in this design guide provides key features, product dimensions and installation specifications. Before installing a Thermador Island Hood, be sure to verify the dimensions and electrical connections. Also, always consult with the installation manual packed with the product for complete details before installing.

INSTALLATION OPTIONS

Thermador Island Hoods may be installed above a Thermador Range or Cooktop to create a convenient cooking center. Refer to the ventilation selection guide for compatibility.

Hood installation height above a range or cooktop can vary. To obtain the necessary installation height above a Thermador Range or Cooktop, consult the appliance's installation manual.

Thermador Island Hoods are suspended from the ceiling. The minimum ceiling height required is 97 3/16".

ISLAND HOODS

INSTALLATION

HPIN42HS
42-INCH LOW PROFILE ISLAND HOOD

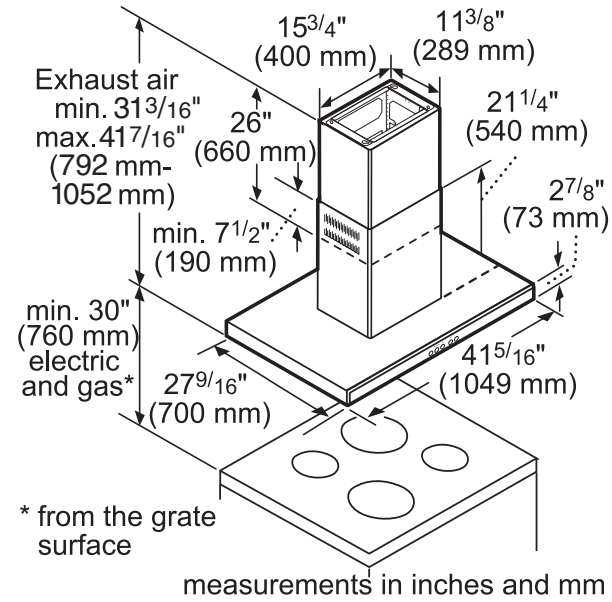

HPIN48HS
48-INCH LOW PROFILE ISLAND HOOD

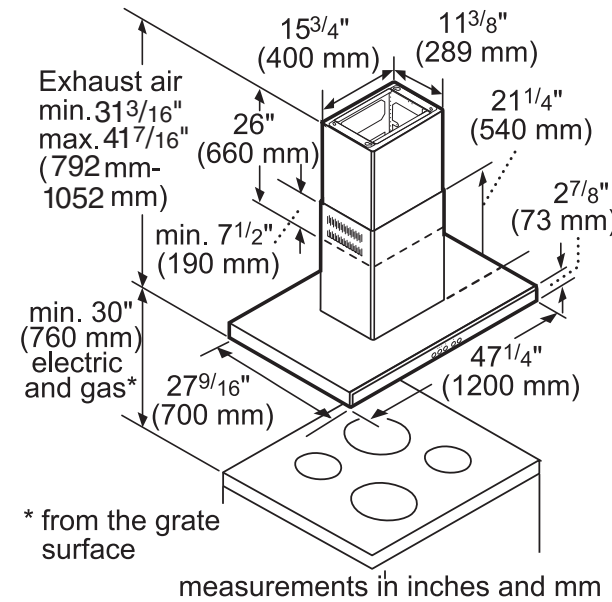

HPIB42HS
42-INCH LOW PROFILE ISLAND HOOD WITH BLOWER

EXTERNAL EXHAUST

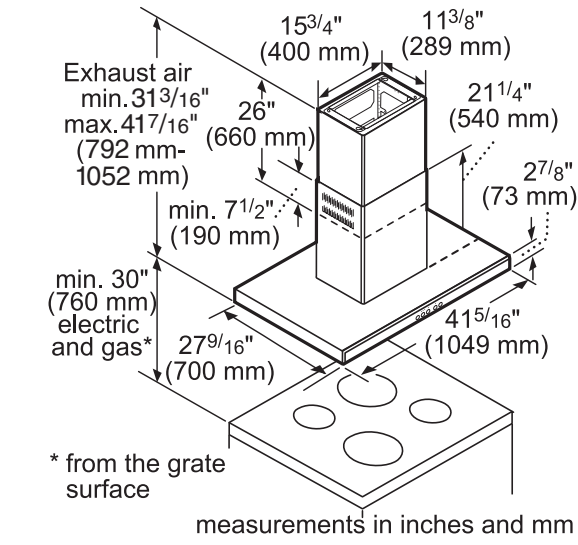

INTERNAL RECIRCULATION

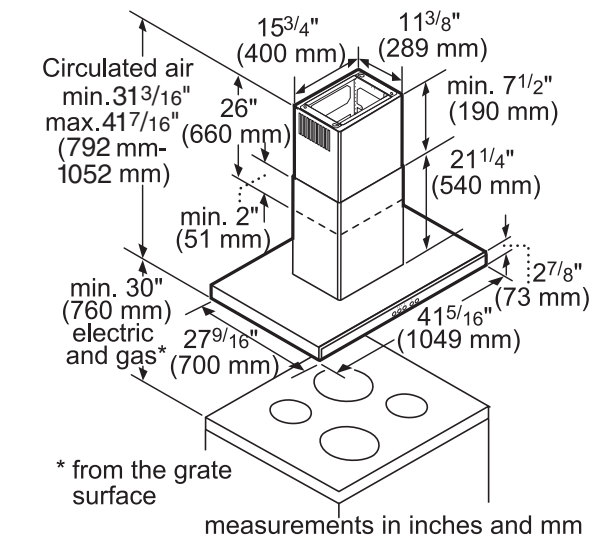

HPIB48HS
48-INCH LOW PROFILE ISLAND HOOD WITH BLOWER

EXTERNAL EXHAUST

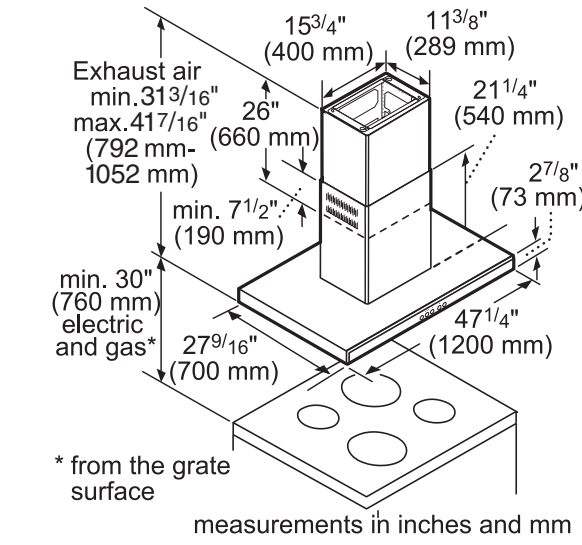

INTERNAL RECIRCULATION

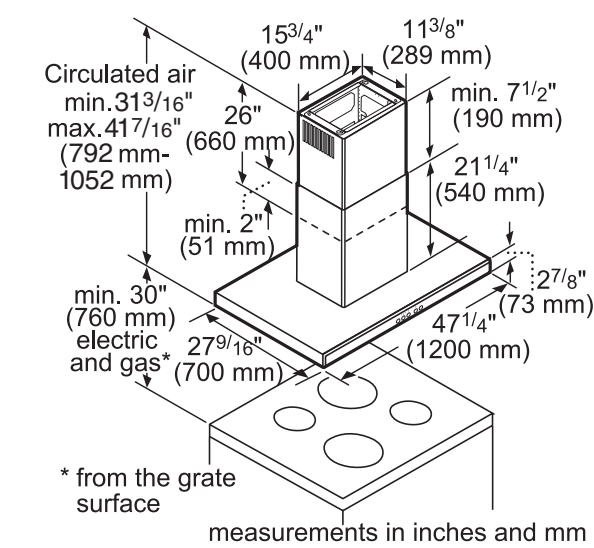

HMIB40HS
40-INCH GLASS ISLAND HOOD WITH BLOWER

EXTERNAL EXHAUST

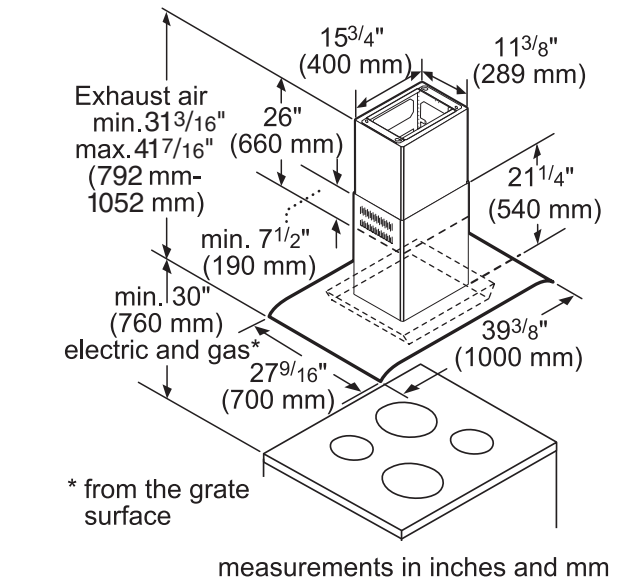

INTERNAL RECIRCULATION

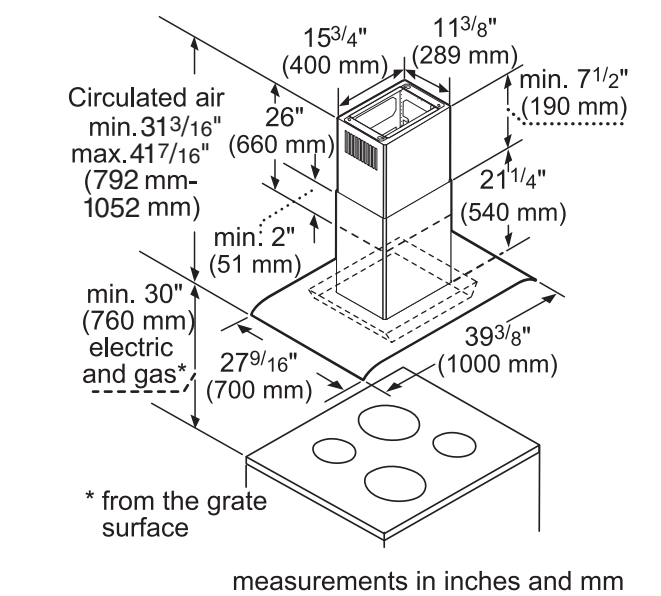

VENTILATION

CUSTOM INSERTS



Custom Inserts VENTILATION

A Thermador® Custom Hood Insert allows the home owner the ultimate creative expression and creates a seamless design option for a wall or island application. These inserts efficiently and quietly remove odor and steam with easy-to-access controls. Inserts are available for both professional and non-professional applications.

CUSTOM HOOD INSERT

Specially designed for professional custom hood applications to create a concealed ventilation system.

TIME-TO-CLEAN-FILTER LIGHT

Easy cleanup: All Thermador ventilation filters are dishwasher-safe, and feature a built-in Time-to-Clean-Filter reminder light.

DELAYED SHUT-OFF

For the greatest efficiency, our Professional ventilation models include delayed shut-off to tackle lingering odors.

PUSH BUTTON CONTROLS

Concealed three-speed, push-button controls are easy to use.

REMOTE VENTILATION CONTROL

Remote controls for customized ventilation applications are easy to use and have a sophisticated and professional style. (photo represents VCI2REMKS)

HALOGEN LIGHTS

Bright halogen lighting spotlights your best recipes.

MESH FILTERS

Aluminum mesh filters with stainless steel frame maximize grease capture without affecting flow. (VCI230DS, VCI236DS, VCI248DS only)

BAFFLE FILTERS

Stainless steel commercial-style baffle filters maximize grease capture and they're dishwasher-safe for easy clean-up. (VCIN and VCIB Series)



VCIN36JP

36-INCH CUSTOM INSERT

PROFESSIONAL SERIES



FEATURES & BENEFITS

- Suitable for wall or island applications
- Three fan speeds
- Auto function senses heat from the cooking surface and adjusts fan speeds
- Built-in 'clean filter' reminder light illuminates after 40 hours of operation
- Delayed shut-off tackles lingering odors for up to 10 minutes
- Dimmer lighting – for a soft lighting effect
- Filter systems are highly efficient at capturing grease

ACCESSORIES (OPTIONAL)

25 ft. Blower Connector Cable - EXTNCB25
For use with the following Inline and Remote Blowers: VTR630P, VTR1030P, VTR1330P, VTI610P, VTI1010P

Custom Hood Liner NOTE: VCIN Custom Insert models include hood trim pieces. VCIN Custom Insert model installations that do not use the included trims may purchase the liner accessory to complete custom insert installation. Liner accessory adds 8 1/8" to overall width, and 4 1/8" to overall depth of appliance. See dimensional line drawings "WITH LINER" for more information	LINER236
Remote Control Panel	VCI2REMKS
Roofplates	
RFPLT600P - For use with 600 CFM Remote Blower VTR630P	
RFPLT1000P - For use with 1000 CFM Remote Blower VTR1030P and 1300 CFM Blower VTR1330P	
8" Wall Cap	WC8
10" Wall Cap	WC10
Roof Jack and Transition	RJ310



Remote Control Panel

GENERAL PROPERTIES	
Operating Mode	Ducted
Number of Speed Settings	3-Stage
Motor Location	N/A
Number of Lights	2
Bulb Type	40 W - G9 Base
Total Power of the Lamps (W)	40 W
Damper Included	Yes
Grease Filter Material	Washable Stainless Steel
Grease Filter Type	Stainless-Steel Commercial Style Baffle Filter

TECHNICAL DETAILS	
Watts (W)	1,020 W
Current (A)	15 A
Volts (V)	120 V
Frequency (Hz)	60 Hz
Plug Type	Fixed Connection
Power Cord / Conduit Length (in)	Direct Wire at Junction Box

DIMENSIONS & WEIGHT	
Overall Appliance Dimensions (Width of Canopy Included) (HxWxD) (in)	12 13/16" x 33 3/4" x 22"
Required Distance Above Cooktop / Range Cooking Surface	30" Electric / 30" Gas
Diameter of Air Duct (in.) Top	10"
Net Weight (lbs)	54 lbs

ACCESSORIES (REQUIRED)	
Blower (Sold Separately)	

BLOWER OPTIONS	
Remote Blowers (Mounted to Roof or External Wall)	VTR630P - 600 CFM
	VTR1030P - 1000 CFM
	VTR1330P - 1300 CFM
Inline Blowers (Mounted Between Kitchen and External Wall)	VTI610P - 600 CFM
	VTI1010P - 1000 CFM
Integrated Blower (Mounted in Hood)	VTN630N - 600 CFM
	VTN1030N - 1000 CFM

WARRANTY	
Limited Warranty Parts and Labor	2 Year

VCIN48JP

48-INCH CUSTOM INSERT

PROFESSIONAL SERIES



FEATURES & BENEFITS

- Suitable for wall or island applications
- Three fan speeds
- Auto function senses heat from the cooking surface and adjusts fan speeds
- Built-in 'clean filter' reminder light illuminates after 40 hours of operation
- Delayed shut-off tackles lingering odors for up to 10 minutes
- Dimmer lighting – for a soft lighting effect
- Filter systems are highly efficient at capturing grease

ACCESSORIES (OPTIONAL)

25 ft. Blower Connector Cable - EXTNCB25
For use with the following Inline and Remote Blowers: VTR630P, VTR1030P, VTR1330P, VTI610P, VTI1010P

Custom Hood Liner NOTE: VCIN Custom Insert models include hood trim pieces. VCIN Custom Insert model installations that do not use the included trims may purchase the liner accessory to complete custom insert installation. Liner accessory adds 8 1/8" to overall width, and 4 1/8" to overall depth of appliance. See dimensional line drawings for more information.	LINER248
Remote Control Panel	VCI2REMKS
Roofplates	
RFPLT600P - For use with 600 CFM Remote Blower VTR630P	
RFPLT1000P - For use with 1000 CFM Remote Blower VTR1030P and 1300 CFM Blower VTR1330P	
8" Wall Cap	WC8
10" Wall Cap	WC10
Roof Jack and Transition	RJ310



Remote Control Panel

GENERAL PROPERTIES	
Operating Mode	Ducted
Number of Speed Settings	3-Stage
Motor Location	N/A
Number of Lights	4
Bulb Type	40 W - G9 Base
Total Power of the Lamps (W)	40 W
Damper Included	Yes
Grease Filter Material	Washable Stainless Steel
Grease Filter Type	Stainless-Steel Commercial Style Baffle Filter

TECHNICAL DETAILS	
Watts (W)	1,020 W
Current (A)	15 A
Volts (V)	120 V
Frequency (Hz)	60 Hz
Plug Type	Fixed Connection
Power Cord / Conduit Length (in)	Direct Wire at Junction Box

DIMENSIONS & WEIGHT	
Overall Appliance Dimensions (Width of Canopy Included) (HxWxD) (in)	12 13/16" x 45 3/4" x 22"
Required Distance Above Cooktop/Range Cooking Surface	30" Electric / 30" Gas
Diameter of Air Duct (in.) Top	10"
Net Weight (lbs)	65 lbs

ACCESSORIES (REQUIRED)	
Blower (Sold Separately)	

BLOWER OPTIONS	
Remote Blowers (Mounted to Roof or External Wall)	VTR630P - 600 CFM
	VTR1030P - 1000 CFM
	VTR1330P - 1300 CFM
Inline Blowers (Mounted Between Kitchen and External Wall)	VTI610P - 600 CFM
	VTI1010P - 1000 CFM
Integrated Blower (Mounted in Hood)	VTN630N - 600 CFM
	VTN1030N - 1000 CFM

WARRANTY	
Limited Warranty Parts and Labor	2 Year

VCIN54JP

54-INCH CUSTOM INSERT

PROFESSIONAL SERIES



48-inch model VCIN48JP shown

FEATURES & BENEFITS

- Suitable for wall or island applications
- Three fan speeds
- Auto function senses heat from the cooking surface and adjusts fan speeds
- Built-in 'clean filter' reminder light illuminates after 40 hours of operation
- Delayed shut-off tackles lingering odors for up to 10 minutes
- Dimmer lighting – for a soft lighting effect
- Filter systems are highly efficient at capturing grease

ACCESSORIES (OPTIONAL)

25 ft. Blower Connector Cable - EXTNCB25

For use with the following Inline and Remote Blowers: VTR630P, VTR1030P, VTR1330P, VTI610P, VTI1010P

Custom Hood Liner NOTE: VCIN Custom Insert models include hood trim pieces. VCIN Custom Insert model installations that do not use the included trims may purchase the liner accessory to complete custom insert installation. Liner accessory adds 8 1/8" to overall width, and 4 1/8" to overall depth of appliance. See dimensional line drawings for more information.	LINER254
Remote Control Panel	VCI2REMKS
Roofplates RFPLT600P - For use with 600 CFM Remote Blower VTR630P RFPLT1000P - For use with 1000 CFM Remote Blower VTR1030P and 1300 CFM Blower VTR1330P	
8" Wall Cap	WC8
10" Wall Cap	WC10
Roof Jack and Transition	RJ310



Remote Control Panel

GENERAL PROPERTIES	
Operating Mode	Ducted
Number of Speed Settings	3-Stage
Motor Location	N/A
Number of Lights	4
Bulb Type	40 W - G9 Base
Total Power of the Lamps (W)	40 W
Damper Included	Yes
Grease Filter Material	Washable Stainless Steel
Grease Filter Type	Stainless-Steel Commercial Style Baffle Filter

TECHNICAL DETAILS	
Watts (W)	1,020 W
Current (A)	15 A
Volts (V)	120 V
Frequency (Hz)	60 Hz
Plug Type	Fixed Connection
Power Cord / Conduit Length (in)	Direct Wire at Junction Box

DIMENSIONS & WEIGHT	
Overall Appliance Dimensions (Width of Canopy Included) (HxWxD) (in)	12 13/16" x 51 3/4" x 22"
Required Distance Above Cooktop/Range Cooking Surface	30" Electric / 30" Gas
Diameter of Air Duct (in.) Top	10"
Net Weight (lbs)	73 lbs

ACCESSORIES (REQUIRED)	
Blower (Sold Separately)	

BLOWER OPTIONS	
Remote Blowers (Mounted to Roof or External Wall)	VTR630P - 600 CFM
	VTR1030P - 1000 CFM
	VTR1330P - 1300 CFM
Inline Blowers (Mounted Between Kitchen and External Wall)	VTI610P - 600 CFM
	VTI1010P - 1000 CFM
Integrated Blower (Mounted in Hood)	VTN630N - 600 CFM
	VTN1030N - 1000 CFM

WARRANTY	
Limited Warranty Parts and Labor	2 Year

VCIN60RP

60-INCH CUSTOM INSERT

PROFESSIONAL SERIES



FEATURES & BENEFITS

- Suitable for wall or island applications
- Three fan speeds
- Auto function senses heat from the cooking surface and adjusts fan speeds
- Built-in 'clean filter' reminder light illuminates after 40 hours of operation
- Delayed shut-off tackles lingering odors for up to 10 minutes
- Dimmer lighting – for a soft lighting effect
- Filter systems are highly efficient at capturing grease

ACCESSORIES (OPTIONAL)

25 ft. Blower Connector Cable - EXTNCB25

For use with the following Inline and Remote Blowers: VTR1030P, VTR1330P, VTI1010P

NOTE: VCIN Custom Insert models include hood trim pieces.

Roofplates	
RFPLT1000P - For use with 1000 CFM Remote Blower VTR1030P and 1300 CFM Blower VTR1330P	
8" Wall Cap	WC8
10" Wall Cap	WC10
Roof Jack and Transition	RJ310

GENERAL PROPERTIES	
Operating Mode	Ducted
Number of Speed Settings	3-Stage
Motor Location	N/A
Number of Lights	4
Bulb Type	40 W - G9 Base
Total Power of the Lamps (W)	40 W
Damper Included	Yes
Grease Filter Material	Washable Stainless Steel
Grease Filter Type	Stainless-Steel Commercial Style Baffle Filter

TECHNICAL DETAILS	
Watts (W)	1,020 W
Current (A)	15 A
Volts (V)	120 V
Frequency (Hz)	60 Hz
Plug Type	Fixed Connection
Power Cord / Conduit Length (in)	Direct Wire at Junction Box

DIMENSIONS & WEIGHT	
Overall Appliance Dimensions (Width Of Canopy Included) (HxWxD) (in)	12 7/8" x 56 1/4" x 20 5/8"
Required Distance Above Cooktop/Range Cooking Surface	30" Electric / 30" Gas
Diameter of Air Duct (in.) Top	10"
Net Weight (lbs)	81 lbs

ACCESSORIES (REQUIRED)	
Blower (Sold Separately)	

BLOWER OPTIONS	
Remote Blowers (Mounted to Roof or External Wall)	VTR1030P - 1000 CFM
	VTR1330P - 1300 CFM
Inline Blowers (Mounted Between Kitchen and External Wall)	VTI1010P - 1000 CFM
Integrated Blower (Mounted in Hood)	VTN1090R - 1000 CFM

WARRANTY	
Limited Warranty Parts and Labor	2 Year

VCIB36JP

36-INCH CUSTOM INSERT WITH BLOWER

PROFESSIONAL SERIES



FEATURES & BENEFITS

- A unique all in one box solution that includes the hood, a 1,000 CFM blower, liner, baffle filters, lights, transition and a back-draft damper
- Suitable for wall or island applications
- Three fan speeds with a delayed shut-off that tackles lingering odors for up to 10 minutes
- Auto function senses heat from the cooking surface and adjusts fan speeds
- Built-in 'clean filter' reminder light illuminates after 40 hours of operation
- Dimmer lighting – for a soft lighting effect
- Filter systems are highly efficient at capturing grease

ACCESSORIES (OPTIONAL)

Custom Hood Installation Trim NOTE: VCIB Custom Insert models include a hood liner accessory. VCIB Custom Insert model installations that do not use the included liner must purchase the trims accessory to complete custom insert installation. See dimensional line drawings for more information.	TRIMS236
Remote Control Panel	VCI2REMKS
8" Wall Cap	WC8
10" Wall Cap	WC10
Roof Jack and Transition	RJ310



Remote Control Panel

GENERAL PROPERTIES

Operating Mode	Ducted
Number of Speed Settings	3-Stage
Motor Location	Integrated Motor In Hood Body
Number of Lights	2
Bulb Type	40 W - G9 Base
Total Power of the Lamps (W)	40 W
Damper Included	Yes
Grease Filter Material	Washable Stainless Steel
Grease Filter Type	Stainless-Steel Commercial Style Baffle Filter

TECHNICAL DETAILS

Watts (W)	1,020 W
Current (A)	15 A
Volts (V)	120 V
Frequency (Hz)	60 Hz
Plug Type	Fixed Connection
Power Cord / Conduit Length (in)	Direct Wire at Junction Box

DIMENSIONS & WEIGHT

Overall Appliance Dimensions (Width of Canopy Included) (HxWxD) (in)	14 5/16" x 40 1/2" x 24 3/4"
Required Distance Above Cooktop/Range Cooking Surface	30" Electric / 30" Gas
Diameter of Air Duct (in.) Top	10"
Net Weight (lbs)	86 lbs

BLOWER OPTIONS

Remote Blowers (Mounted to Roof or External Wall)	N/A
Inline Blowers (Mounted Between Kitchen and External Wall)	N/A
Integrated Blower (Mounted in Hood)	N/A

WARRANTY

Limited Warranty Parts and Labor	2 Year
----------------------------------	--------

VCIB48JP

48-INCH CUSTOM INSERT WITH BLOWER

PROFESSIONAL SERIES



FEATURES & BENEFITS

- A unique all in one box solution that includes the hood, a 1,000 CFM blower, liner, baffle filters, lights, transition and a back-draft damper
- Suitable for wall or island applications
- Three fan speeds with a delayed shut-off that tackles lingering odors for up to 10 minutes
- Auto function senses heat from the cooking surface and adjusts fan speeds
- Built-in 'clean filter' reminder light illuminates after 40 hours of operation
- Dimmer lighting – for a soft lighting effect
- Filter systems are highly efficient at capturing grease

ACCESSORIES (OPTIONAL)

Custom Hood Installation Trim NOTE: VCIB Custom Insert models include a hood liner accessory. VCIB Custom Insert model installations that do not use the included liner must purchase the trims accessory to complete custom insert installation. See dimensional line drawings for more information.	TRIMS248
Remote Control Panel	VCI2REMKS
8" Wall Cap	WC8
10" Wall Cap	WC10
Roof Jack and Transition	RJ310



Remote Control Panel

GENERAL PROPERTIES

Operating Mode	Ducted
Number of Speed Settings	3-Stage
Motor Location	Integrated Motor In Hood Body
Number of Lights	4
Bulb Type	40 W - G9 Base
Total Power of the Lamps (W)	40 W
Damper Included	Yes
Grease Filter Material	Washable Stainless Steel
Grease Filter Type	Stainless-Steel Commercial Style Baffle Filter

TECHNICAL DETAILS

Watts (W)	1,020 W
Current (A)	15 A
Volts (V)	120 V
Frequency (Hz)	60 Hz
Plug Type	Fixed Connection
Power Cord / Conduit Length (in)	Direct Wire at Junction Box

DIMENSIONS & WEIGHT

Overall Appliance Dimensions (Width of Canopy Included) (HxWxD) (in)	14 5/16" x 52 1/2" x 24 3/4"
Required Distance Above Cooktop/Range Cooking Surface	30" Electric / 30" Gas
Diameter of Air Duct (in.) Top	10"
Net Weight (lbs)	99 lbs

BLOWER OPTIONS

Remote Blowers (Mounted to Roof or External Wall)	N/A
Inline Blowers (Mounted Between Kitchen and External Wall)	N/A
Integrated Blower (Mounted in Hood)	N/A

WARRANTY

Limited Warranty Parts and Labor	2 Year
----------------------------------	--------

VCIB54JP

54-INCH CUSTOM INSERT WITH BLOWER

PROFESSIONAL SERIES



48-inch model VCIB48JP shown



FEATURES & BENEFITS

- A unique all in one box solution that includes the hood, a 1,000 CFM blower, liner, baffle filters, lights, transition and a back-draft damper
- Suitable for wall or island applications
- Three fan speeds with a delayed shut-off that tackles lingering odors for up to 10 minutes
- Auto function senses heat from the cooking surface and adjusts fan speeds
- Built-in 'clean filter' reminder light illuminates after 40 hours of operation
- Dimmer lighting – for a soft lighting effect
- Filter systems are highly efficient at capturing grease

ACCESSORIES (OPTIONAL)

Custom Hood Installation Trim NOTE: VCIB Custom Insert models include a hood liner accessory. VCIB Custom Insert model installations that do not use the included liner must purchase the trims accessory to complete custom insert installation. See dimensional line drawings for more information.	TRIMS254
Remote Control Panel	VCI2REMKS
8" Wall Cap	WC8
10" Wall Cap	WC10
Roof Jack and Transition	RJ310



Remote Control Panel

GENERAL PROPERTIES

Operating Mode	Ducted
Number of Speed Settings	3-Stage
Motor Location	Integrated Motor In Hood Body
Number of Lights	4
Bulb Type	40 W - G9 Base
Total Power of the Lamps (W)	40 W
Damper Included	Yes
Grease Filter Material	Washable Stainless Steel
Grease Filter Type	Stainless-Steel Commercial Style Baffle Filter

TECHNICAL DETAILS

Watts (W)	1,020 W
Current (A)	15 A
Volts (V)	120 V
Frequency (Hz)	60 Hz
Plug Type	Fixed Connection
Power Cord / Conduit Length (in)	Direct Wire at Junction Box

DIMENSIONS & WEIGHT

Overall Appliance Dimensions (Width of Canopy Included) (HxWxD) (in)	14 5/16" x 58 1/2" x 24 3/4"
Required Distance Above Cooktop/Range Cooking Surface	30" Electric / 30" Gas
Diameter of Air Duct (in.) Top	10"
Net Weight (lbs)	109 lbs

BLOWER OPTIONS

Remote Blowers (Mounted to Roof or External Wall)	N/A
	N/A
	N/A
Inline Blowers (Mounted Between Kitchen and External Wall)	N/A
	N/A
Integrated Blower (Mounted in Hood)	N/A

WARRANTY

Limited Warranty Parts and Labor	2 Year
----------------------------------	--------

VCI230DS

30-INCH CUSTOM INSERT

MASTERPIECE® SERIES



FEATURES & BENEFITS

- Suitable for wall or island applications
- Three fan speeds
- Built-in 'clean filter' reminder light illuminates after 40 hours of operation
- Delayed shut-off tackles lingering odors for up to 10 minutes
- Powerfully quiet® ventilation systems

ACCESSORIES (OPTIONAL)

25 ft. Blower Connector Cable - EXTNCB25

For use with the following Inline and Remote Blowers: VTR630P, VTR1030P, VTR1330P, VTI610P, VTI1010P

Custom Hood Liner	LINER30
Remote Control Panel	VCI2REMFS
30" Baffle Filter	BAFFLT30
Roofplates	
RFPLT600P - For use with 600 CFM Remote Blower VTR630P	
RFPLT1000P - For use with 1000 CFM Remote Blower VTR1030P and 1300 CFM Blower VTR1330P	
8" Wall Cap	WC8
10" Wall Cap	WC10
Roof Jack and Transition	RJ310



Remote Control Panel

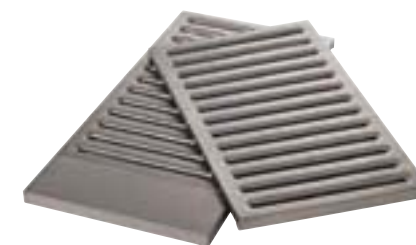

Baffle Filters

GENERAL PROPERTIES

Operating Mode	Ducted
Number of Speed Settings	3-Stage
Motor Location	N/A
Number of Lights	2
Bulb Type	20 W - G4 Base
Total Power of the Lamps (W)	20 W
Damper Included	No
Grease Filter Material	Washable Synthetic
Grease Filter Type	Multilayer Cassette

TECHNICAL DETAILS

Watts (W)	40 W
Current (A)	15 A
Volts (V)	120 V
Frequency (Hz)	60 Hz
Plug Type	120V-3 Prong
Power Cord / Conduit Length (in)	51 1/8"

DIMENSIONS & WEIGHT

Overall Appliance Dimensions (Width of Canopy Included) (HxWxD) (in)	5 3/4" / 5 3/4" x 28" x 18 5/8"
Required Distance Above Cooktop/Range Cooking Surface	30" Electric / 30" Gas
Diameter of Air Duct (in.) Top	10"
Net Weight (lbs)	24 lbs

ACCESSORIES (REQUIRED)

Blower (Sold Separately)

BLOWER OPTIONS

Remote Blowers (Mounted to Roof or External Wall)	VTR630P - 600 CFM
	VTR1030P - 1000 CFM
	VTR1330P - 1300 CFM
Inline Blowers (Mounted Between Kitchen and External Wall)	VTI610P - 600 CFM
	VTI1010P - 1000 CFM
Integrated Blower (Mounted in Hood)	VTI610P* - 600 CFM
	VTI1010P* - 1000 CFM

WARRANTY

Limited Warranty Parts and Labor	2 Year
----------------------------------	--------

*Inline blower can be used as an integrated solution. Refer to installation manual for details.

VCI236DS

36-INCH CUSTOM INSERT

MASTERPIECE® SERIES



FEATURES & BENEFITS

- Suitable for wall or island applications
- Three fan speeds
- Built-in 'clean filter' reminder light illuminates after 40 hours of operation
- Delayed shut-off tackles lingering odors for up to 10 minutes
- Powerfully quiet® ventilation systems

ACCESSORIES (OPTIONAL)

25 ft. Blower Connector Cable - EXTNCB25

For use with the following Inline and Remote Blowers: VTR630P, VTR1030P, VTR1330P, VT1610P, VT11010P

Custom Hood Liner	LINER36
Remote Control Panel	VCI2REMFS
36" Baffle Filter	BAFFLT36

Roofplates

RFPLT600P - For use with 600 CFM Remote Blower VTR630P

RFPLT1000P - For use with 1000 CFM Remote Blower VTR1030P and 1300 CFM Blower VTR1330P

8" Wall Cap	WC8
10" Wall Cap	WC10
Roof Jack and Transition	RJ310



Remote Control Panel



Baffle Filters

GENERAL PROPERTIES

Operating Mode	Ducted
Number of Speed Settings	3-Stage
Motor Location	N/A
Number of Lights	2
Bulb Type	20 W - G4 Base
Total Power of the Lamps (W)	20 W
Damper Included	No
Grease Filter Material	Washable Synthetic
Grease Filter Type	Multilayer Cassette

TECHNICAL DETAILS

Watts (W)	40 W
Current (A)	15 A
Volts (V)	120 V
Frequency (Hz)	60 Hz
Plug Type	120V-3 Prong
Power Cord / Conduit Length (in)	51 1/8"

DIMENSIONS & WEIGHT

Overall Appliance Dimensions (Width of Canopy Included) (HxWxD) (in)	5 3/4" / 5 3/4" x 33 5/8" x 18 5/8"
Required Distance Above Cooktop/Range Cooking Surface	30" Electric / 30" Gas
Diameter of Air Duct (in.) Top	10"
Net Weight (lbs)	27 lbs

ACCESSORIES (REQUIRED)

Blower (Sold Separately)

BLOWER OPTIONS

Remote Blowers (Mounted to Roof or External Wall)	VTR630P - 600 CFM
	VTR1030P - 1000 CFM
	VTR1330P - 1300 CFM
Inline Blowers (Mounted Between Kitchen and External Wall)	VT1610P - 600 CFM
	VT11010P - 1000 CFM
Integrated Blower (Mounted in Hood)	VT1610P* - 600 CFM
	VT11010P* - 1000 CFM

WARRANTY

Limited Warranty Parts and Labor	2 Year
----------------------------------	--------

*Inline blower can be used as an integrated solution. Refer to installation manual for details.

VCI248DS

48-INCH CUSTOM INSERT

MASTERPIECE® SERIES



FEATURES & BENEFITS

- Suitable for wall or island applications
- Three fan speeds
- Built-in 'clean filter' reminder light illuminates after 40 hours of operation
- Delayed shut-off tackles lingering odors for up to 10 minutes
- Powerfully quiet® ventilation systems

ACCESSORIES (OPTIONAL)

25 ft. Blower Connector Cable - EXTNCB25

For use with the following Inline and Remote Blowers: VTR630P, VTR1030P, VTR1330P, VT1610P, VT11010P

Custom Hood Liner	LINER48
Remote Control Panel	VCI2REMFS
48" Baffle Filter	BAFFLT48

Roofplates

RFPLT600P - For use with 600 CFM Remote Blower VTR630P

RFPLT1000P - For use with 1000 CFM Remote Blower VTR1030P and 1300 CFM Blower VTR1330P

8" Wall Cap	WC8
10" Wall Cap	WC10
Roof Jack and Transition	RJ310



Remote Control Panel

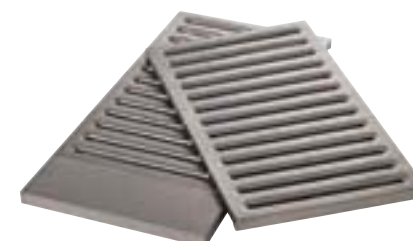

Baffle Filters

GENERAL PROPERTIES

Operating Mode	Ducted
Number of Speed Settings	3-Stage
Motor Location	N/A
Number of Lights	4
Bulb Type	20 W - G4 Base
Total Power of the Lamps (W)	20 W
Damper Included	No
Grease Filter Material	Washable Synthetic
Grease Filter Type	Multilayer Cassette

TECHNICAL DETAILS

Watts (W)	80 W
Current (A)	15 A
Volts (V)	120 V
Frequency (Hz)	60 Hz
Plug Type	120V-3 Prong
Power Cord / Conduit Length (in)	51 1/8"

DIMENSIONS & WEIGHT

Overall Appliance Dimensions (Width of Canopy Included) (HxWxD) (in)	5 3/4" / 5 3/4" x 43 5/8" x 18 5/8"
Required Distance Above Cooktop/Range Cooking Surface	30" Electric / 30" Gas
Diameter of Air Duct (in.) Top	10"
Net Weight (lbs)	32 lbs

ACCESSORIES (REQUIRED)

Blower (Sold Separately)

BLOWER OPTIONS

Remote Blowers (Mounted to Roof or External Wall)	VTR630P - 600 CFM
	VTR1030P - 1000 CFM
	VTR1330P - 1300 CFM
Inline Blowers (Mounted Between Kitchen and External Wall)	VT1610P - 600 CFM
	VT11010P - 1000 CFM
Integrated Blower (Mounted in Hood)	VT1610P* - 600 CFM
	VT11010P* - 1000 CFM

WARRANTY

Limited Warranty Parts and Labor	2 Year
----------------------------------	--------

*Inline blower can be used as an integrated solution. Refer to installation manual for details.

CUSTOM INSERTS

PLANNING INFORMATION

MODEL OPTIONS

Thermador Custom Hood Inserts are available for both professional and non-professional applications. The Professional Series Custom Hood Inserts are available in 36-inch, 48-inch, 54-inch and 60-inch widths. The Masterpiece® Series Custom Hood Inserts are available in 30-inch, 36-inch, and 48-inch widths.

ELECTRICAL SPECIFICATIONS

Be sure your Thermador Custom Insert is properly installed and grounded by a qualified technician. Installation, electrical connections and grounding must comply with all applicable local codes.

MODEL	REQUIRED CIRCUIT BREAKER
	120V AC, 60 Hz
VCIN36JP	15 A
VCIN48JP	15 A
VCIN54JP	15 A
VCIN60RP	15 A
VCIB36JP	15 A
VCIB48JP	15 A
VCIB54JP	15 A
VCI230DS	15 A
VCI236DS	15 A
VCI248DS	15 A

INSTALLATION CONSIDERATIONS

The information in this design guide provides key features, product dimensions and installation specifications. Before installing a Thermador Custom Hood Insert, be sure to verify the dimensions and electrical connections. Also, always consult with the installation manual packed with the product for complete details before installing.

INSTALLATION OPTIONS

Thermador Custom Hood Inserts may be installed above a Thermador Range or Cooktop to create a convenient cooking center. Refer to the ventilation selection guide for compatibility.

Hood installation height above a range or cooktop can vary. To obtain the necessary installation height above a Thermador Range or Cooktop, consult the appliance's installation manual.

Thermador Custom Hood Inserts within custom hood applications create a seamless design with wall or island applications.

TRANSITIONS

- Included with VCIN__JP models and VCIB__JP models
- 10" round downdraft transition
- Required for installation of 1000 and 1300 CFM inline and remote blowers

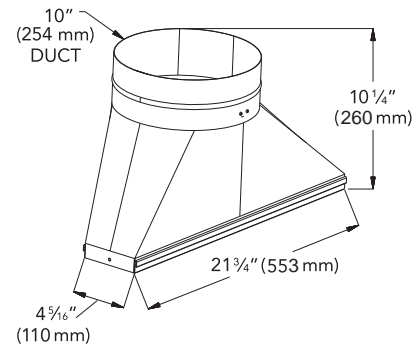

VCIN36JP 36-INCH CUSTOM INSERT

WITHOUT LINER

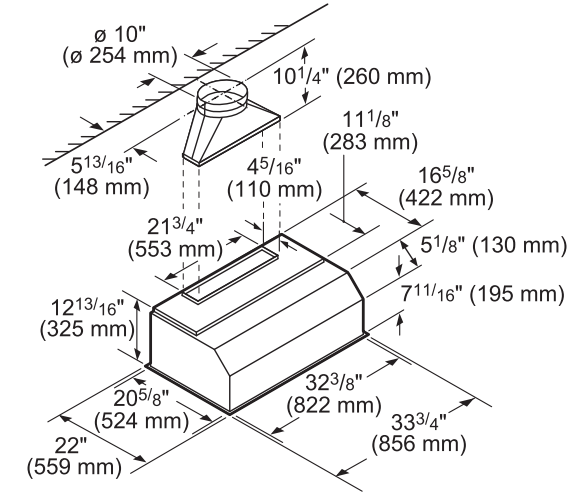

NOTE: VCIN Custom Insert models include hood trim pieces. VCIN Custom Insert model installations that do not use the included trims may purchase the liner accessory to complete custom insert installation. Liner accessory adds 8 1/8" to overall width, and 4 1/8" to overall depth of appliance. See dimensional line drawing "WITH LINER" for more information.

WITH LINER

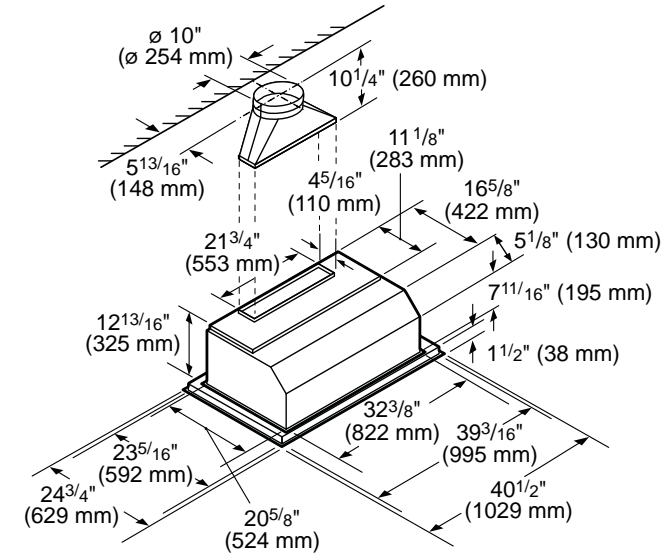

CUTOUT FOR CUSTOM INSERT WITHOUT LINER ACCESSORY

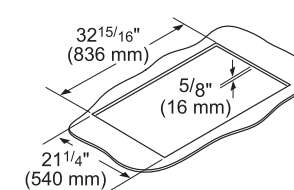

CUTOUT FOR CUSTOM INSERT WITH LINER ACCESSORY LINER236

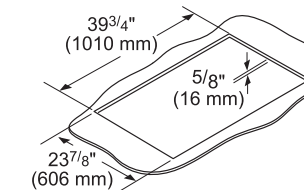

VCIN48JP 48-INCH CUSTOM INSERT

WITHOUT LINER

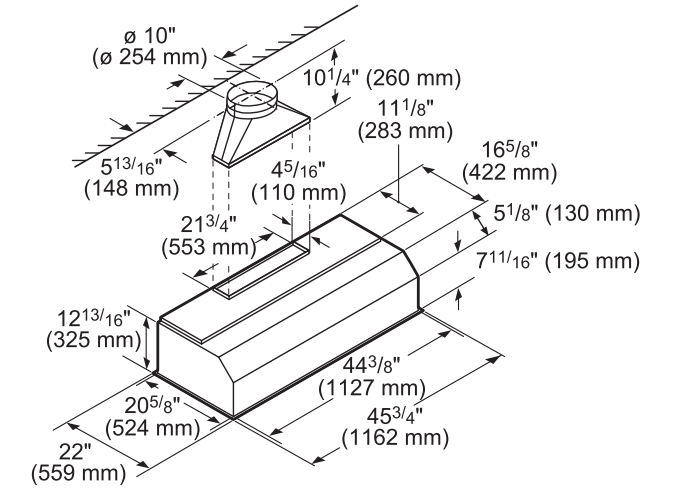

NOTE: VCIN Custom Insert models include hood trim pieces. VCIN Custom Insert model installations that do not use the included trims may purchase the liner accessory to complete custom insert installation. Liner accessory adds 8 1/8" to overall width, and 4 1/8" to overall depth of appliance. See dimensional line drawing "WITH LINER" for more information.

WITH LINER

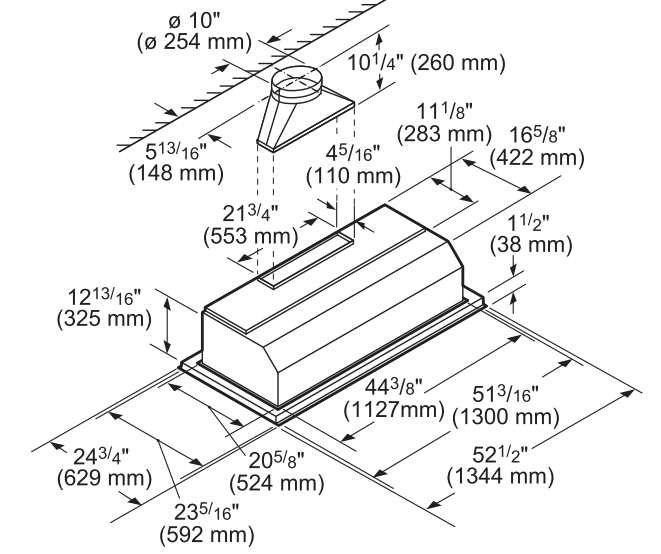

CUTOUT FOR CUSTOM INSERT WITHOUT LINER ACCESSORY

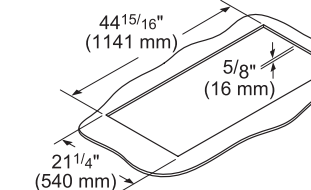

CUTOUT FOR CUSTOM INSERT WITH LINER ACCESSORY LINER248

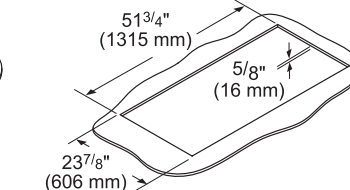

CUSTOM INSERTS INSTALLATION

VCIN54JP 54-INCH CUSTOM INSERT

WITHOUT LINER

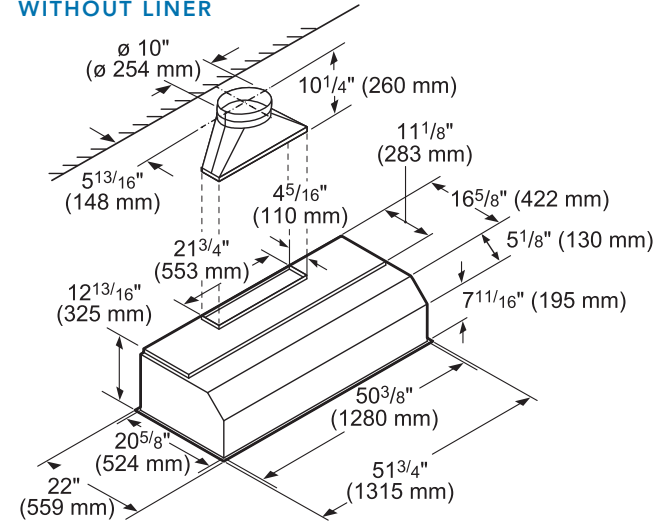

NOTE: VCIN Custom Insert models include hood trim pieces. VCIN Custom Insert model installations that do not use the included trims may purchase the liner accessory to complete custom insert installation. Liner accessory adds 8 1/8" to overall width, and 4 1/8" to overall depth of appliance. See dimensional line drawing "WITH LINER" for more information.

WITH LINER

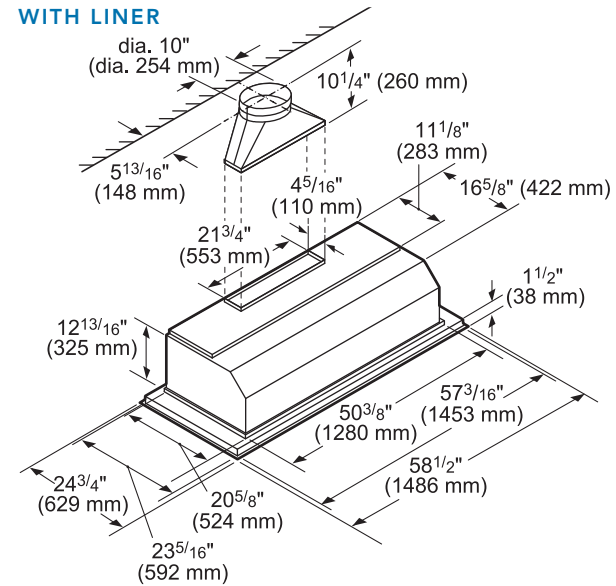

CUTOUT FOR 54-INCH CUSTOM INSERT WITHOUT LINER ACCESSORY

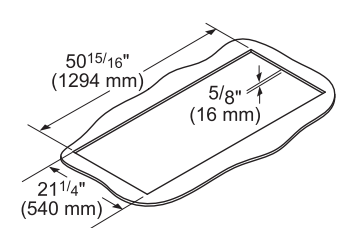

CUTOUT FOR 54-INCH CUSTOM INSERT WITH LINER ACCESSORY LINER254

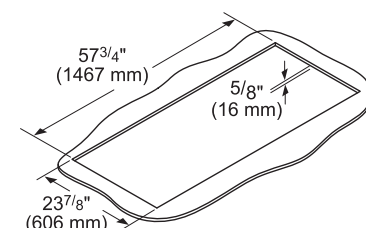

VCIN60RP 60-INCH CUSTOM INSERT

WITHOUT LINER

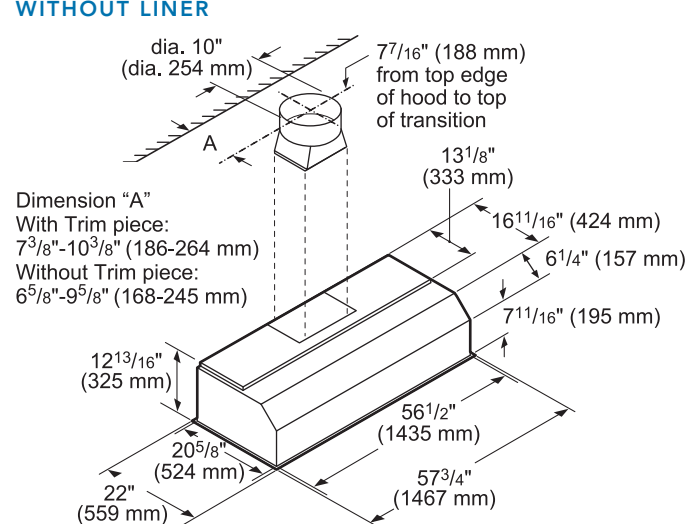

NOTE: VCIN Custom Insert models include hood trim pieces.

CUTOUT FOR 60-INCH CUSTOM INSERT WITHOUT LINER ACCESSORY

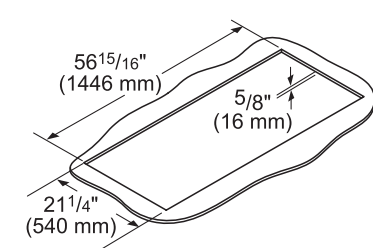

VCIB36JP 36-INCH CUSTOM INSERT WITH BLOWER

WITH LINER

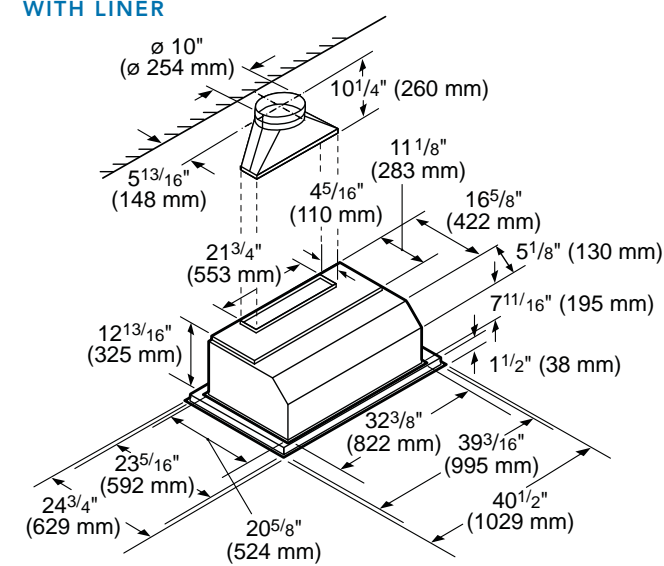

NOTE: VCIB Custom Insert models include a hood liner accessory. VCIB Custom Insert model installations that do not use the included liner must purchase the trims accessory to complete custom insert installation. See dimensional line drawing "WITHOUT LINER" for more information.

WITHOUT LINER

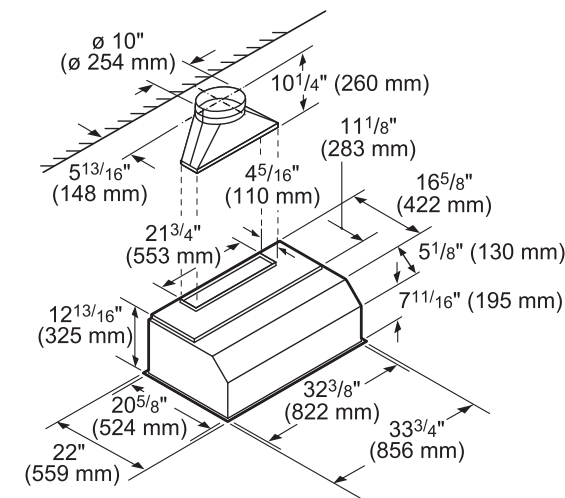

CUTOUT FOR CUSTOM INSERT WITH LINER ACCESSORY LINER236

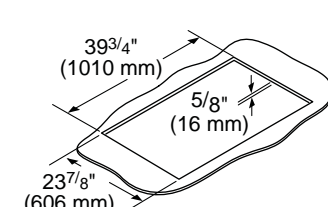

CUTOUT FOR CUSTOM INSERT WITHOUT LINER ACCESSORY

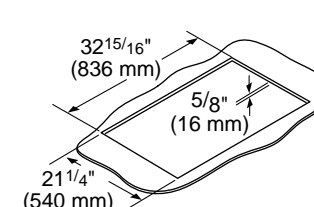

VCIB48JP 48-INCH CUSTOM INSERT WITH BLOWER

WITH LINER

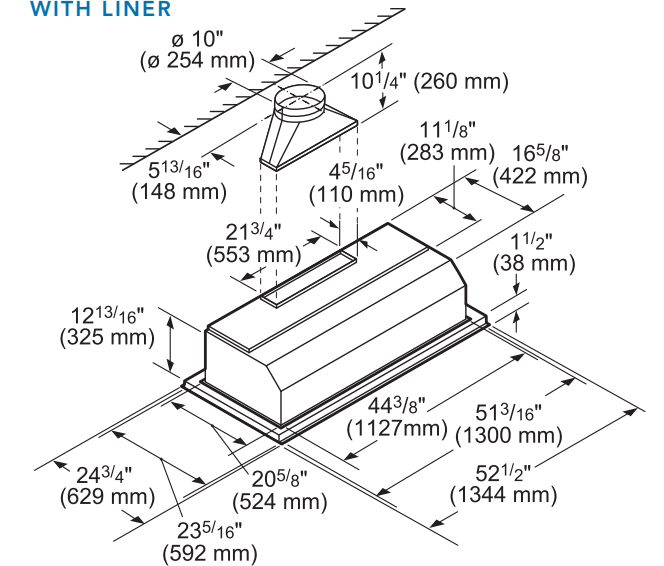

NOTE: VCIB Custom Insert models include a hood liner accessory. VCIB Custom Insert model installations that do not use the included liner must purchase the trims accessory to complete custom insert installation. See dimensional line drawing "WITHOUT LINER" for more information.

WITHOUT LINER

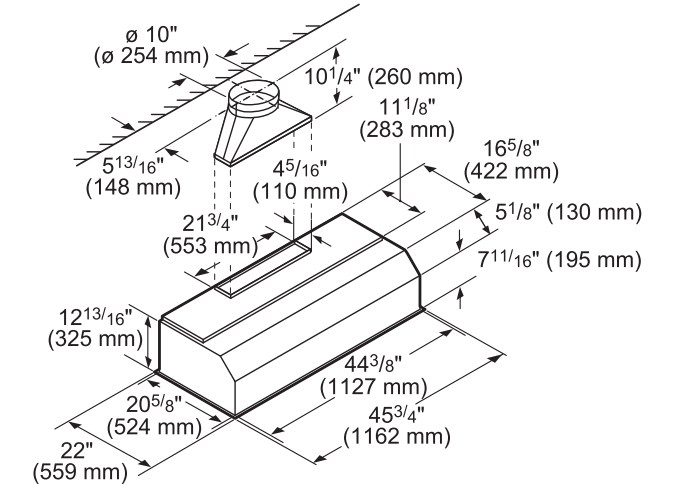

CUTOUT FOR CUSTOM INSERT WITH LINER ACCESSORY LINER248

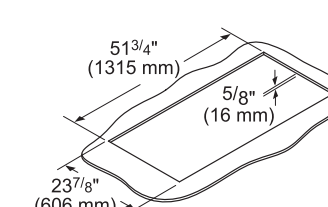

CUTOUT FOR CUSTOM INSERT WITHOUT LINER ACCESSORY

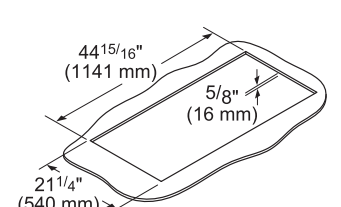

CUSTOM INSERTS INSTALLATION

VCIB54JP 54-INCH CUSTOM INSERT WITH BLOWER

WITH LINER

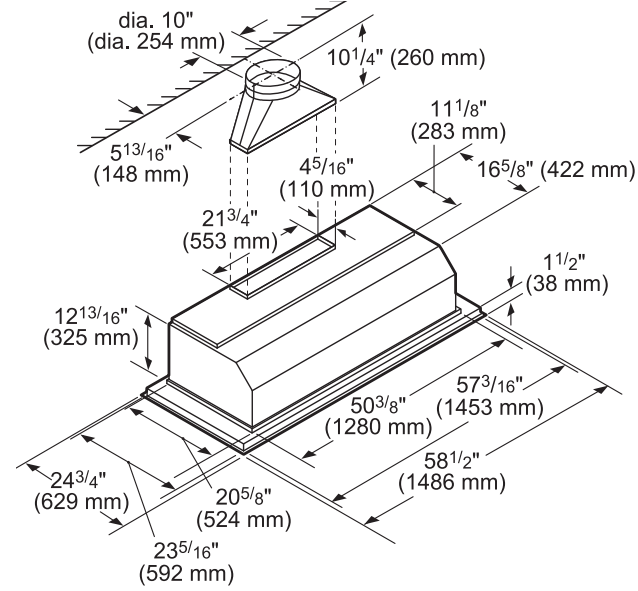

NOTE: VCIB Custom Insert models include a hood liner accessory. VCIB Custom Insert model installations that do not use the included liner must purchase the trims accessory to complete custom insert installation. See dimensional line drawing "WITHOUT LINER" for more information.

WITHOUT LINER

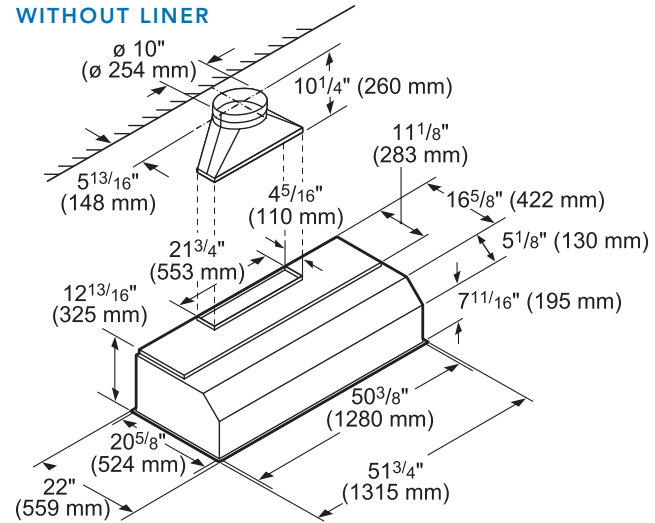

CUTOUT FOR 54-INCH CUSTOM INSERT WITH LINER ACCESSORY LINER254

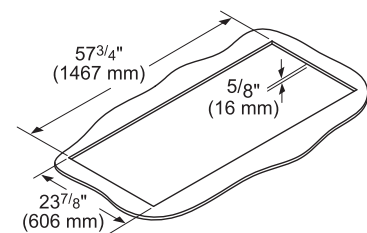

CUTOUT FOR 54-INCH CUSTOM INSERT WITHOUT LINER ACCESSORY

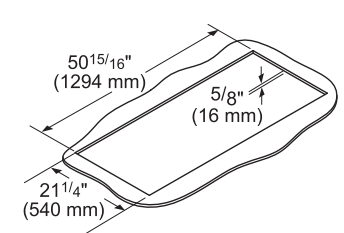

VC1230DS 30-INCH CUSTOM INSERT

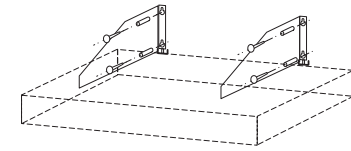
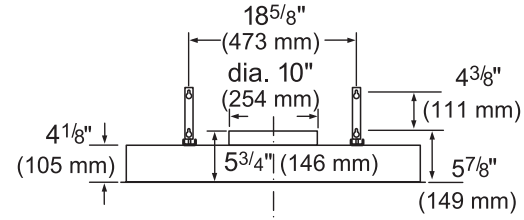

measurements in inches and mm

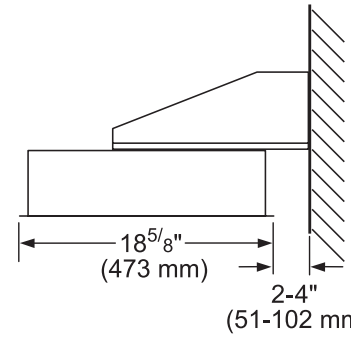

measurements in inches and mm

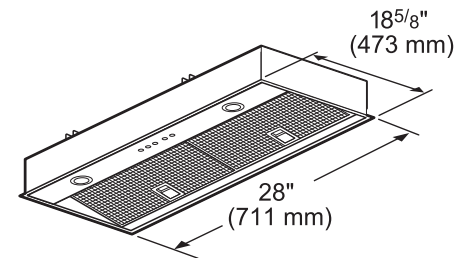

measurements in inches and mm

CUTOUT FOR INSERT WITHOUT LINER ACCESSORY

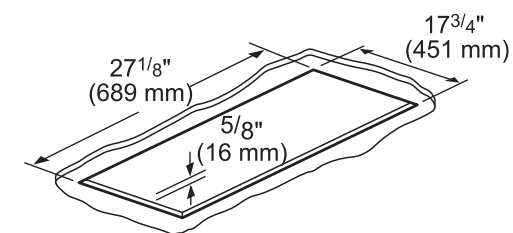

measurements in inches and mm

VC1236DS 36-INCH CUSTOM INSERT

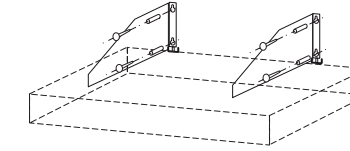
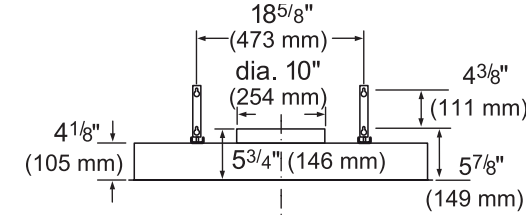

measurements in inches and mm

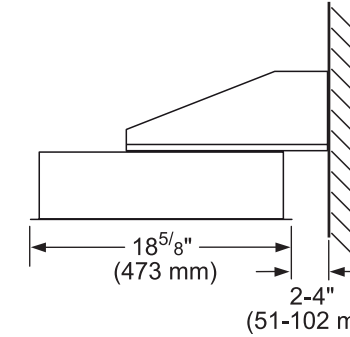

measurements in inches and mm

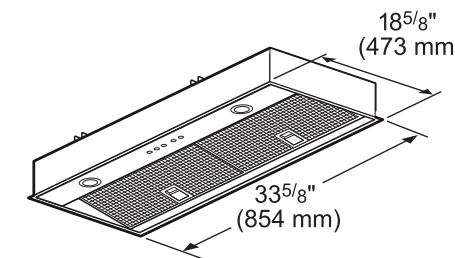

measurements in inches and mm

CUTOUT FOR INSERT WITHOUT LINER ACCESSORY

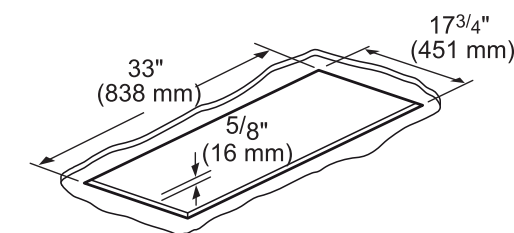

measurements in inches and mm

VC1248DS 48-INCH CUSTOM INSERT

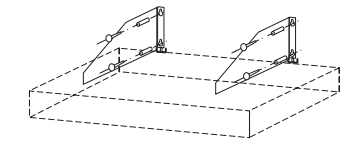
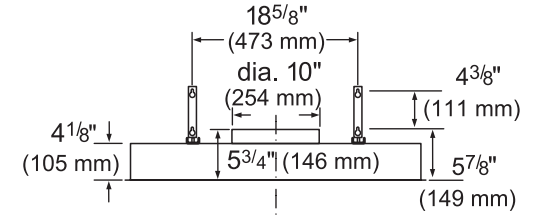

measurements in inches and mm

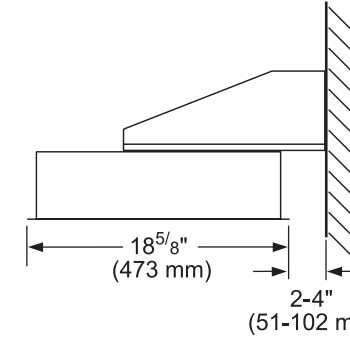

measurements in inches and mm

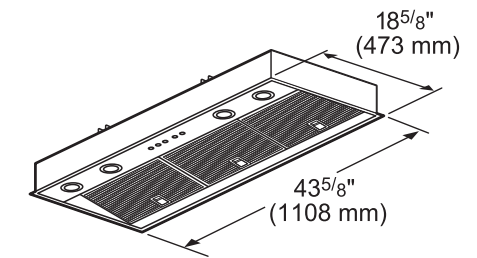

measurements in inches and mm

CUTOUT FOR INSERT WITHOUT LINER ACCESSORY

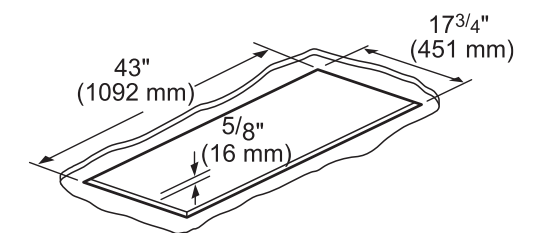

measurements in inches and mm

VENTILATION

DOWNDRAFT



Downdraft VENTILATION

If you prefer a clean, contemporary design, choose Thermador® Downdraft Ventilation, which offers space efficiency as well as a concealed look versus an exposed hood. The full-face filter combines a filter with a splatter shield in one easy-to-remove, dishwasher-safe element.

FULL 13-INCH RISE

With an over 13-inch intake, the UCVM downdraft rises well above even the tallest pans. This protects against splatters when cooking and provides better performance in capturing steam and smoke—even from the front burners.

DOWNDRAFT RECIRCULATION OPTION

Downdraft recirculation is available for island or wall applications. Combine the performance of the UCVM Downdraft with the odor- and grease-capturing filters in the Recirculation Module for the perfect ventilation combination for anywhere in your kitchen.

FULL-FACE FILTERS

Full-face filters combine a filter with a splatter shield in one easy-to-remove, dishwasher-safe element. These filters maximize grease capture without affecting airflow.



UCVM30FS

30-INCH DOWNDRAFT VENTILATION

MASTERPIECE® SERIES



FEATURES & BENEFITS

- Suitable for wall or island applications
- Downdraft rises over 13" to capture steam from the tallest pots
- Downdraft recirculation possible with module RECIRC36DF
- Three fan speeds
- Dishwasher-safe full-face filters also act as a splatter shield

ACCESSORIES (OPTIONAL)

25 ft. Blower Connector Cable

EXTNCB25 - For use with the following Inline and Remote Blowers: VTR630P, VTR1030P, VTR1330P, VTI610P, VTI1010P

Recirculation Kit

RECIRC36DF - Includes 2 charcoal filters, 2 venting grids, and ducting to transition to Integrated Blower (blower sold separately)

Roofplates

RFPLT600P - For use with Remote Blower VTR630P

RFPLT1000P - For use with 1000 CFM Remote Blower VTR1030P and 1300 CFM Blower VTR1330P

Replacement Charcoal Filters

Service Item #291108

GENERAL PROPERTIES

Operating Mode	Convertible: Ducted / Recirculating
Maximum CFM	Blower Sold Separately
Number of Speed Settings	3-Stage
Motor Location	External
Damper Included	No
Grease Filter Material	Washable Synthetic
Grease Filter Type	Multilayer Cassette

TECHNICAL DETAILS

Current (A)	10 A
Volts (V)	120 V
Frequency (Hz)	60 Hz
Plug Type	120V-3 prong
Power Cord Length (in)	57"

DIMENSIONS & WEIGHT

Overall Appliance Dimensions (Width of Canopy Included) (HxWxD) (in)	34 1/2" x 30 7/8" x 3 3/4"
Height of the Rise (in.)	13"
Diameter of Air Duct (in.) Back	10"
Net Weight (lbs)	37 lbs

ACCESSORIES (REQUIRED)

Blower (Sold Separately)

BLOWERS AND TRANSITIONS

Remote Blowers

VTR630P - 600 CFM (Requires Transition CV2T6)

VTR1030P - 1000 CFM (Requires Transition CV2T10)

Inline Blowers

VTI610P - 600 CFM (Requires Transition CV2T6)

VTI1010P - 1000 CFM (Requires Transition CV2T10)

Integrated Blower

VTN600CV2C - 600 CFM

Remote and Inline Blower Downdraft Transitions

CV2T6 - Required for installation of 600 CFM Inline and Remote Blowers with 6" duct connections

CV2T10 - Required for installation of 1000 CFM Inline and Remote Blowers with 10" duct connections

WARRANTY

Limited Warranty Parts and Labor	2 Year
----------------------------------	--------

UCVM36FS

36-INCH DOWNDRAFT VENTILATION

MASTERPIECE® SERIES

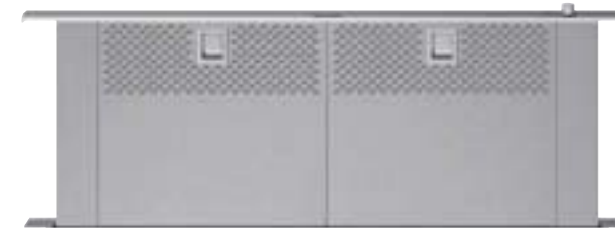

FEATURES & BENEFITS

- Suitable for wall or island applications
- Downdraft rises over 13" to capture steam from the tallest pots
- Downdraft recirculation possible with module RECIRC36DF
- Three fan speeds
- Dishwasher-safe full-face filters also act as a splatter shield

ACCESSORIES (OPTIONAL)

25 ft. Blower Connector Cable

EXTNCB25 - For use with the following Inline and Remote Blowers: VTR630P, VTR1030P, VTR1330P, VTI610P, VTI1010P

Recirculation Kit

RECIRC36DF - Includes 2 charcoal filters, 2 venting grids, and ducting to transition to Integrated Blower (blower sold separately)

Roofplates

RFPLT600P - For use with Remote Blower VTR630P

RFPLT1000P - For use with 1000 CFM Remote Blower VTR1030P and 1300 CFM Blower VTR1330P

Replacement Charcoal Filters

Service Item #291108

GENERAL PROPERTIES

Operating Mode	Convertible: Ducted / Recirculating
Maximum CFM	Blower Sold Separately
Number of Speed Settings	3-Stage
Motor Location	External
Damper Included	No
Grease Filter Material	Washable Synthetic
Grease Filter Type	Multilayer Cassette

TECHNICAL DETAILS

Current (A)	10 A
Volts (V)	120 V
Frequency (Hz)	60Hz
Plug Type	120V-3 prong
Power Cord Length (in)	57"

DIMENSIONS & WEIGHT

Overall Appliance Dimensions (Width of Canopy Included) (HxWxD) (in)	34 1/2" x 36 7/8" x 3 3/4"
Height of the Rise (in.)	13"
Diameter of Air Duct (in.) Back	10"
Net Weight (lbs)	42 lbs

ACCESSORIES (REQUIRED)

Blower (Sold Separately)

BLOWERS AND TRANSITIONS

Remote Blowers

VTR630P - 600 CFM (Requires Transition CV2T6)

VTR1030P - 1000 CFM (Requires Transition CV2T10)

Inline Blowers

VTI610P - 600 CFM (Requires Transition CV2T6)

VTI1010P - 1000 CFM (Requires Transition CV2T10)

Integrated Blower

VTN600CV2C - 600 CFM

Remote and Inline Blower Downdraft Transitions

CV2T6 - Required for installation of 600 CFM Inline and Remote Blowers with 6" duct connections

CV2T10 - Required for installation of 1000 CFM Inline and Remote Blowers with 10" duct connections

WARRANTY

Limited Warranty Parts and Labor	2 Year
----------------------------------	--------

DOWNDRAFT

PLANNING INFORMATION

MODEL OPTIONS

Thermador Downdraft Hoods are available in 30 and 36-inch widths to fit your kitchen plans and are meticulously crafted for both function and design. Be sure to reference the correct model information in this design guide.

ELECTRICAL SPECIFICATIONS

Be sure your Thermador Downdraft Hood is properly installed and grounded by a qualified technician. Installation, electrical connections and grounding must comply with all applicable local codes.

MODEL	REQUIRED CIRCUIT BREAKER
	120V AC, 60 Hz
UCVM30FS	10 A
UCVM36FS	10 A

INSTALLATION CONSIDERATIONS

The information in this design guide provides key features, product dimensions, cutouts and installation specifications. Before installing a Thermador Downdraft Hood, be sure to verify the cutout dimensions and electrical connections. Also, always consult with the installation manual packed with the product for complete details before installing.

INSTALLATION OPTIONS

The Thermador Downdraft Hood System is available in 30-inch or 36-inch widths. It is intended for installation with Thermador non-professional gas, electric or induction cooktops only.

Thermador Downdraft Hoods may be installed in a wall or island behind a Thermador non-professional gas, electric or induction cooktop to create a convenient cooking center. Refer to the ventilation selection guide for compatibility.

DOWNDRAFT

INSTALLATION

UCVM30FS 30-INCH DOWNDRAFT VENTILATION

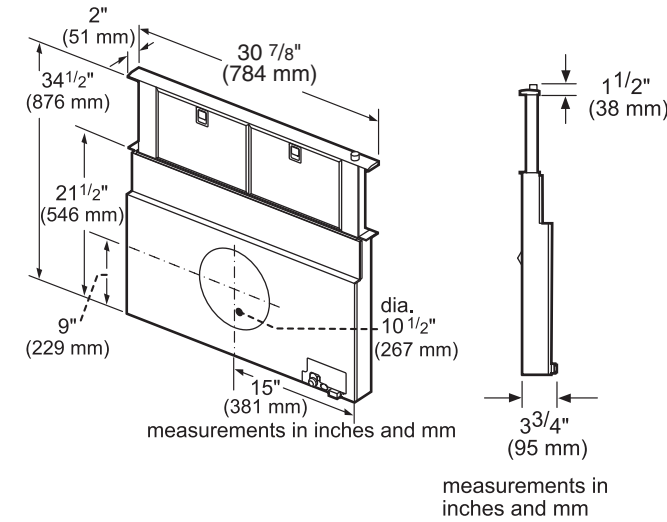

UCVM36FS 36-INCH DOWNDRAFT VENTILATION

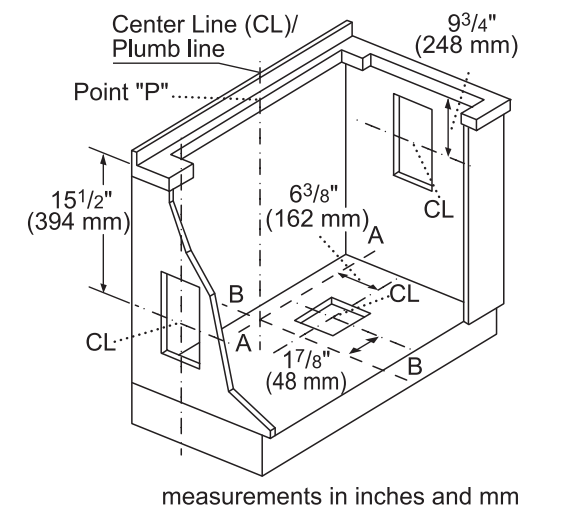
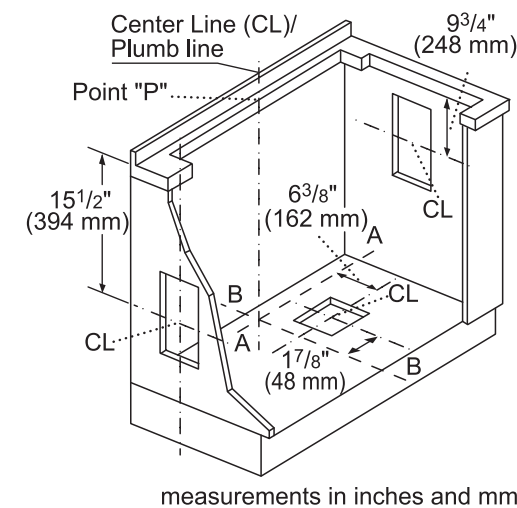
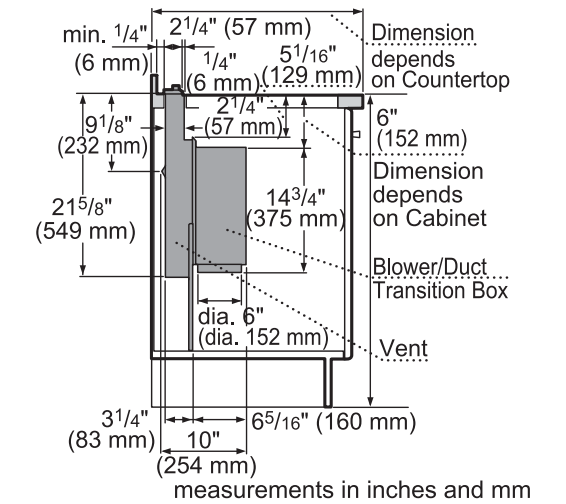
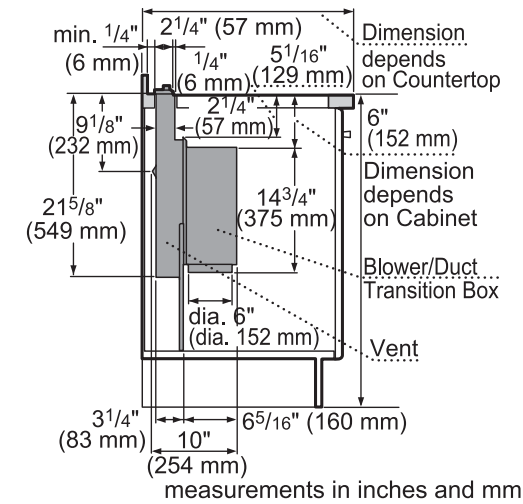
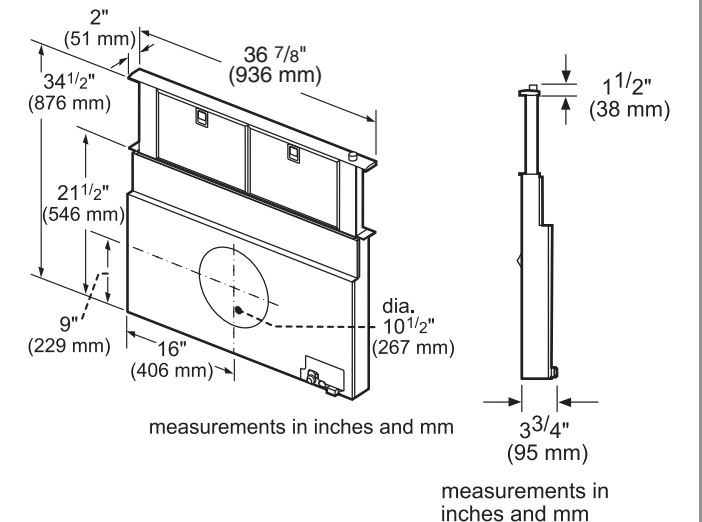

DOWNDRAFT INSTALLATION

DOWNDRAFT INSTALLATION

CUTOUT DIMENSIONS (TOP VIEW)

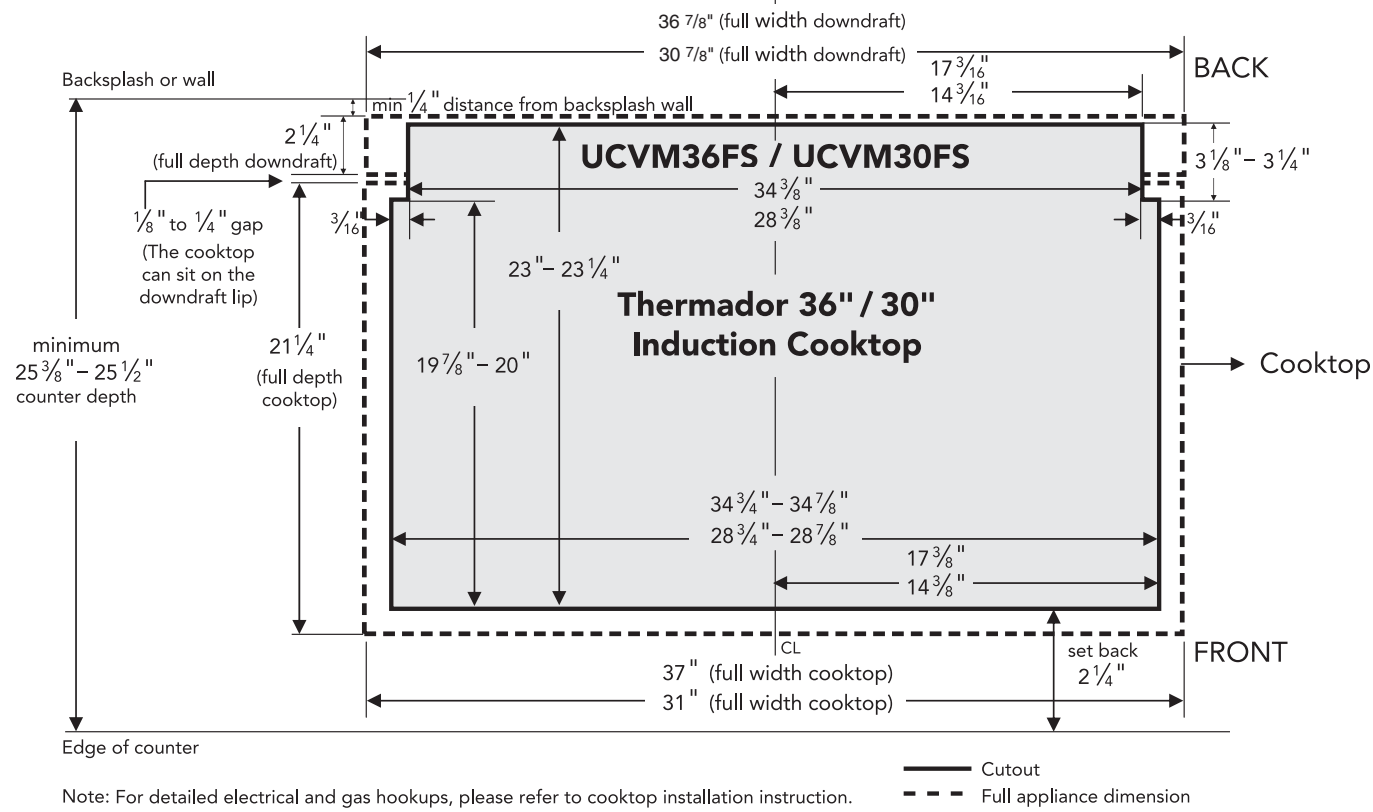

CUTOUT DIMENSIONS (TOP VIEW)

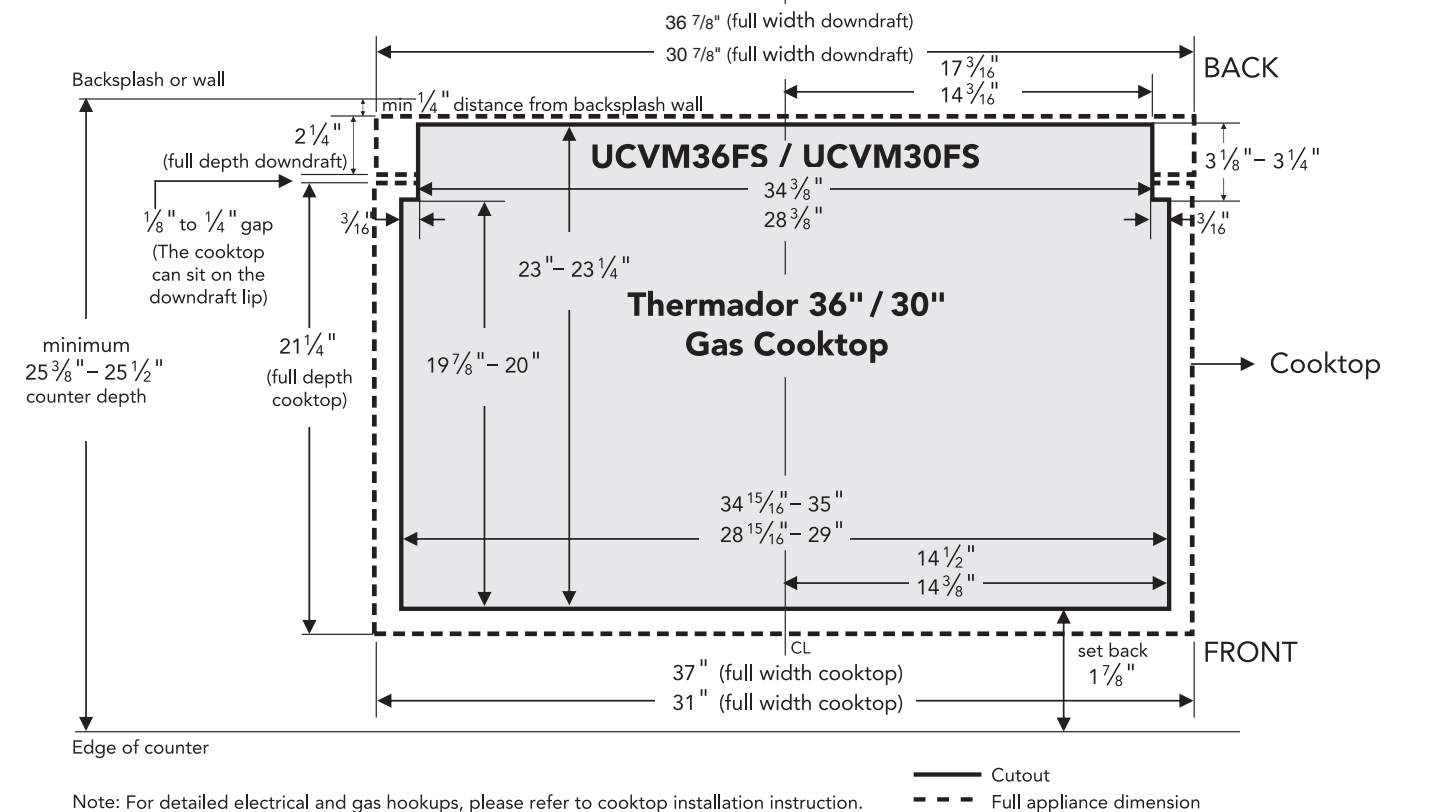

CUTOUT DIMENSIONS (TOP VIEW)

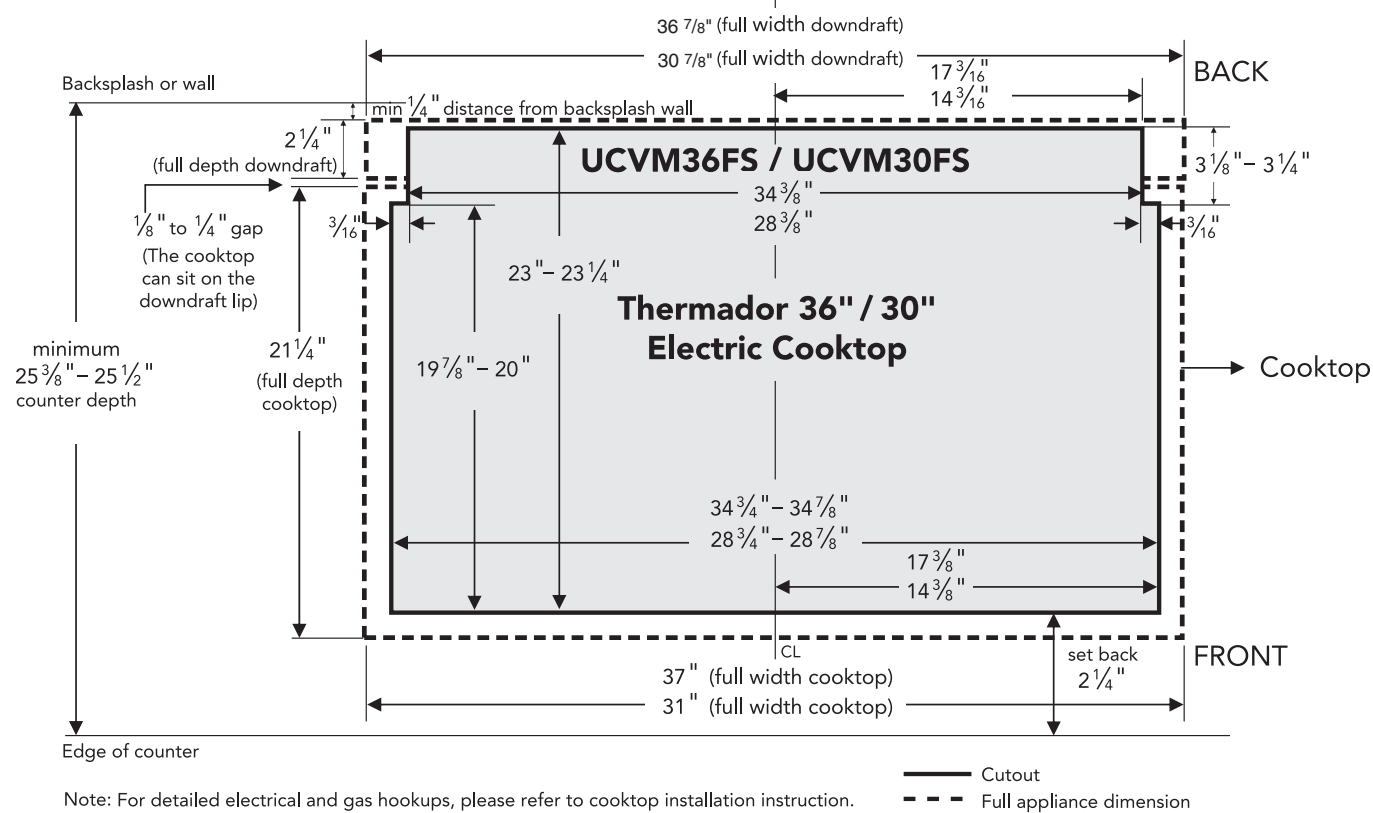



WARMING DRAWERS

TRADITIONAL & CONVECTION

Traditional

For the ultimate in elegance, practicality and convenience, complete your Thermador kitchen with a spacious, built-in warming drawer. Keep food warm until every dish is ready to be served. It's the ultimate indulgence for the culinary enthusiast.

Convection

Our convection warming drawer is the perfect combination of uncompromising performance and unique convenience features. Its ceramic warming surface not only heats faster and more evenly to keep food hot until it's ready to serve—it's also easier to clean. A special convection mode offers superior heat distribution, allowing you to warm tall stacks of dinner plates evenly and quickly. We've also added a unique touch control panel with a digital display for easy activation and temperature monitoring and kept the sides of the drawer open for easy accessibility.



MODEL SHOWN: WDC30J WARMING DRAWER WITH CUSTOM WOOD PANEL

Warming Drawers THE PERFECT ACCOMPANIMENT

★ SOFTCLOSE® DRAWER

SoftClose doors prevent slamming and ensure ultra smooth closing of the Warming Drawer.

★ CERAMIC SURFACE

Convection Warming Drawers boast a state-of-the-art glass-ceramic surface that uses a powerful element to ensure quick and even heating. It's easy-to-clean and you can place food directly on the surface.

CONVECTION WARMING

The 400 Watt convection heater allows you to evenly, quickly and effortlessly heat large stacks of plates and can even be used to dehydrate food, such as fruit.

TOUCH CONTROL

This convenient feature boasts a digital display to easily activate and monitor any one of the 4 temperature settings. It also includes an electronic timer, a hot-surface indicator, and an automatic shut-off feature.

TELESCOPIC RAILS

These rails feature a telescoping ball-bearing design for smooth opening and closing that supports up to 40 lbs. on traditional models and 55 lbs. on convection models.

EASY ACCESS

The open sides make it easier and more convenient to load and remove plates from the spacious drawer cavity.

EASY CUSTOM PANEL INSTALLATION

Our custom panel ready model lets you create a custom panel to match the warming drawer to existing cabinetry. The fully flush-mounted design lets you achieve a seamless appearance. Together, these features offer the ultimate in design flexibility.

★ THERMADOR® EXCLUSIVE



WD27JS
27-INCH TRADITIONAL WARMING DRAWER
MASTERPIECE® SERIES HANDLE



FEATURES & BENEFITS

- ★ - SoftClose® hinges for ultra smooth closing of the warming drawer
- Telescopic ball-bearing rails offer smooth handling and support up to 40 lbs
- Warming Mode with three convenient temperature settings
- Special Proof Mode
- Moisture selector controls humidity level in the drawer

GENERAL PROPERTIES

Power Levels	High, Low, Medium
Dough Proofing Mode	Yes
Plate Warming Mode (for multiple plates)	No
Warming Mode	Yes
Temperature Settings	F140 - F165 - F190 (Proof: F100)
Timer	Yes
Automatic Shut Off After 1 Hour	Yes
Door Opening	Pull Handle
Hinges	SoftClose®
Wattage Heating Element(s)	450 W
Easy-Clean Glass Ceramic Surface	No
Control Type	Touch Control With Blue Digital Display

CAPACITY

Cavity Capacity (cu. ft.)	2.3 cu. ft.
Holds Up To ___ Dinner Plates	20

TECHNICAL DETAILS

Watts (W)	450 W
Circuit Breaker (A)	15 A
Volts (V)	120 V
Frequency (Hz)	60 Hz
Power Cord Length (in)	84"
Plug Type	120V 3-Wire

DIMENSIONS & WEIGHT

Overall Appliance Dimensions (HxWxD) (in)	11 1/4" x 26 3/4" x 23 7/8"
Required Cutout Size (HxWxD) (in)	11" x 25 1/2" x 23 3/8"
Net Weight (lbs)	85 lbs

WARRANTY

Limited Warranty Parts and Labor	2 Year
----------------------------------	--------

WD30JS
30-INCH TRADITIONAL WARMING DRAWER
MASTERPIECE® SERIES HANDLE



FEATURES & BENEFITS

- ★ - SoftClose® hinges for ultra smooth closing of the warming drawer
- Telescopic ball-bearing rails offer smooth handling and support up to 40 lbs
- Warming Mode with three convenient temperature settings
- Special Proof Mode
- Moisture selector controls humidity level in the drawer

GENERAL PROPERTIES

Power Levels	High, Low, Medium
Dough Proofing Mode	Yes
Plate Warming Mode (for multiple plates)	No
Warming Mode	Yes
Temperature Settings	F140 - F165 - F190 (Proof: F100)
Timer	Yes
Automatic Shut Off After 1 Hour	Yes
Door Opening	Pull Handle
Hinges	SoftClose®
Wattage Heating Element(s)	450 W
Easy-Clean Glass Ceramic Surface	No
Control Type	Touch Control With Blue Digital Display

CAPACITY

Cavity Capacity (cu. ft.)	2.6 cu. ft.
Holds Up To ___ Dinner Plates	27

TECHNICAL DETAILS

Watts (W)	450 W
Circuit Breaker (A)	15 A
Volts (V)	120 V
Frequency (Hz)	60 Hz
Power Cord Length (in)	84"
Plug Type	120V 3-Wire

DIMENSIONS & WEIGHT

Overall Appliance Dimensions (HxWxD) (in)	11 1/4" x 29 3/4" x 23 7/8"
Required Cutout Size (HxWxD) (in)	11" x 28 1/2" x 23 3/8"
Net Weight (lbs)	80 lbs

WARRANTY

Limited Warranty Parts and Labor	2 Year
----------------------------------	--------

WD30JP
30-INCH TRADITIONAL WARMING DRAWER
 PROFESSIONAL SERIES HANDLE



FEATURES & BENEFITS

- ★ - SoftClose® hinges for ultra smooth closing of the warming drawer
- Telescopic ball-bearing rails offer smooth handling and support up to 40 lbs
- Warming Mode with three convenient temperature settings
- Special Proof Mode
- Moisture selector controls humidity level in the drawer

GENERAL PROPERTIES

Power Levels	High, Low, Medium
Dough Proofing Mode	Yes
Plate Warming Mode (for multiple plates)	No
Warming Mode	Yes
Temperature Settings	F140 - F165 - F190 (Proof: F100)
Timer	Yes
Automatic Shut Off After 1 Hour	Yes
Door Opening	Pull Handle
Hinges	SoftClose®
Wattage Heating Element(s)	450 W
Easy-Clean Glass Ceramic Surface	No
Control Type	Touch Control With Blue Digital Display

CAPACITY

Cavity Capacity (cu. ft.)	2.6 cu. ft.
Holds Up To __ Dinner Plates	27

TECHNICAL DETAILS

Watts (W)	450 W
Circuit Breaker (A)	15 A
Volts (V)	120 V
Frequency (Hz)	60 Hz
Power Cord Length (in)	84"
Plug Type	120V 3-Wire

DIMENSIONS & WEIGHT

Overall Appliance Dimensions (HxWxD) (in)	11 1/4" x 29 3/4" x 23 7/8"
Required Cutout Size (HxWxD) (in)	11" x 28 1/2" x 23 3/8"
Net Weight (lbs)	80 lbs

WARRANTY

Limited Warranty Parts and Labor	2 Year
----------------------------------	--------

WDC30JS
30-INCH CONVECTION WARMING DRAWER
 MASTERPIECE® SERIES HANDLE



FEATURES & BENEFITS

- ★ - SoftClose® hinges for ultra smooth closing of the warming drawer
- ★ - Easy to clean glass ceramic surface
- Telescopic ball-bearing rails offer smooth handling and support up to 40 lbs
- Warming Mode with three convenient temperature settings
- Powerful 400 Watt convection heater

GENERAL PROPERTIES

Power Levels	High, Low, Medium, Plate
Dough Proofing Mode	No
Plate Warming Mode (for multiple plates)	Yes
Warming Mode	Yes
Temperature Settings	F100 - F120 - F155 (Plate Warming F165)
Timer	Yes
Automatic Shut Off After 1 Hour	Yes
Door Opening	Pull Handle
Hinges	SoftClose®
Wattage Heating Element(s)	930 W
Easy-Clean Glass Ceramic Surface	Yes
Control Type	Touch Control With Blue Digital Display

CAPACITY

Cavity Capacity (cu. ft.)	2.5 cu. ft.
Holds Up To __ Dinner Plates	32

TECHNICAL DETAILS

Watts (W)	930 W
Circuit Breaker (A)	15 A
Volts (V)	120 V
Frequency (Hz)	60 Hz
Power Cord Length (in)	72"
Plug Type	120V 3-Wire

DIMENSIONS & WEIGHT

Overall Appliance Dimensions (HxWxD) (in)	11 1/4" x 29 3/4" x 23 3/8"
Required Cutout Size (HxWxD) (in)	10" x 28 1/2" x 23"
Net Weight (lbs)	72 lbs

WARRANTY

Limited Warranty Parts and Labor	2 Year
----------------------------------	--------

WDC30JP
30-INCH CONVECTION WARMING DRAWER
 PROFESSIONAL SERIES HANDLE



FEATURES & BENEFITS

- ★ - SoftClose® hinges for ultra smooth closing of the warming drawer
- ★ - Easy to clean glass ceramic surface
 - Telescopic ball-bearing rails offer smooth handling and support up to 40 lbs
 - Warming Mode with three convenient temperature settings
 - Powerful 400 Watt convection heater

GENERAL PROPERTIES

Power Levels	High, Low, Medium, Plate
Dough Proofing Mode	No
Plate Warming Mode (for multiple plates)	Yes
Warming Mode	Yes
Temperature Settings	F100 - F120 - F155 (Plate Warming F165)
Timer	Yes
Automatic Shut Off After 1 Hour	Yes
Door Opening	Pull Handle
Hinges	SoftClose®
Wattage Heating Element(s)	930 W
Easy-Clean Glass Ceramic Surface	Yes
Control Type	Touch Control With Blue Digital Display

CAPACITY

Cavity Capacity (cu. ft.)	2.5 cu. ft.
Holds Up To __ Dinner Plates	32

TECHNICAL DETAILS

Watts (W)	930 W
Circuit Breaker (A)	15 A
Volts (V)	120 V
Frequency (Hz)	60 Hz
Power Cord Length (in)	72"
Plug Type	120V 3-Wire

DIMENSIONS & WEIGHT

Overall Appliance Dimensions (HxWxD) (in)	11 1/4" x 29 3/4" x 23 3/8"
Required Cutout Size (HxWxD) (in)	10" x 28 1/2" x 23"
Net Weight (lbs)	72 lbs

WARRANTY

Limited Warranty Parts and Labor	2 Year
----------------------------------	--------

WDC30J
30-INCH CONVECTION WARMING DRAWER
 CUSTOM PANEL READY



FEATURES & BENEFITS

- ★ - SoftClose® hinges for ultra smooth closing of the warming drawer
- ★ - Easy to clean glass ceramic surface
 - Telescopic ball-bearing rails offer smooth handling and support up to 40 lbs
 - Warming Mode with three convenient temperature settings
 - Powerful 400 Watt convection heater

GENERAL PROPERTIES

Power Levels	High, Low, Medium, Plate
Dough Proofing Mode	Yes
Plate Warming Mode (for multiple plates)	Yes
Warming Mode	Yes
Temperature Settings	F100 - F120 - F155 (Plate Warming F165)
Timer	Yes
Automatic Shut Off After 1 Hour	Yes
Door Opening	Pull Handle
Hinges	SoftClose®
Wattage Heating Element(s)	930 W
Easy-Clean Glass Ceramic Surface	Yes
Control Type	Touch Control With Blue Digital Display

CAPACITY

Cavity Capacity (cu. ft.)	2.5 cu. ft.
Holds Up To __ Dinner Plates	32

TECHNICAL DETAILS

Watts (W)	930 W
Circuit Breaker (A)	15 A
Volts (V)	120 V
Frequency (Hz)	60 Hz
Power Cord Length (in)	72"
Plug Type	120V 3-Wire

DIMENSIONS & WEIGHT

Overall Appliance Dimensions (HxWxD) (in)	9 7/8" x 27 5/8" x 21 3/4"
Required Cutout Size (HxWxD) (in)	10" x 28 1/2" x 23"
Net Weight (lbs)	59 lbs

WARRANTY

Limited Warranty Parts and Labor	2 Year
----------------------------------	--------

WDC36JP
36-INCH CONVECTION WARMING DRAWER
 PROFESSIONAL SERIES HANDLE



FEATURES & BENEFITS

- ★ - SoftClose® hinges for ultra smooth closing of the warming drawer
- ★ - Easy to clean glass ceramic surface
 - Telescopic ball-bearing rails offer smooth handling and support up to 40 lbs
 - Warming Mode with three convenient temperature settings
 - Powerful 400 Watt convection heater

GENERAL PROPERTIES

Power Levels	High, Low, Medium, Plate
Dough Proofing Mode	Yes
Plate Warming Mode (for multiple plates)	Yes
Warming Mode	Yes
Temperature Settings	F100 - F120 - F155 (Plate Warming F165)
Timer	Yes
Automatic Shut Off After 1 Hour	Yes
Door Opening	Pull Handle
Hinges	SoftClose®
Wattage Heating Element(s)	1,080 W
Easy-Clean Glass Ceramic Surface	Yes
Control Type	Touch Control With Blue Digital Display

CAPACITY

Cavity Capacity (cu. ft.)	3.1 cu. ft.
Holds Up To __ Dinner Plates	32

TECHNICAL DETAILS

Watts (W)	1,080 W
Circuit Breaker (A)	15 A
Volts (V)	120 V
Frequency (Hz)	60 Hz
Power Cord Length (in)	72"
Plug Type	120V 3-Wire

DIMENSIONS & WEIGHT

Overall Appliance Dimensions (HxWxD) (in)	11 1/4" x 35 3/4" x 23 3/8"
Required Cutout Size (HxWxD) (in)	10" x 34 1/2" x 23"
Net Weight (lbs)	83 lbs

WARRANTY

Limited Warranty Parts and Labor	2 Year
----------------------------------	--------

WDC36J
36-INCH CONVECTION WARMING DRAWER
 CUSTOM PANEL READY



FEATURES & BENEFITS

- ★ - SoftClose® hinges for ultra smooth closing of the warming drawer
- ★ - Easy to clean glass ceramic surface
 - Telescopic ball-bearing rails offer smooth handling and support up to 40 lbs
 - Warming Mode with three convenient temperature settings
 - Powerful 400 Watt convection heater

GENERAL PROPERTIES

Power Levels	High, Low, Medium, Plate
Dough Proofing Mode	Yes
Plate Warming Mode (for multiple plates)	Yes
Warming Mode	Yes
Temperature Settings	F100 - F120 - F155 (Plate Warming F165)
Timer	Yes
Automatic Shut Off After 1 Hour	Yes
Door Opening	Pull Handle
Hinges	SoftClose®
Wattage Heating Element(s)	1,080 W
Easy-Clean Glass Ceramic Surface	Yes
Control Type	Touch Control With Blue Digital Display

CAPACITY

Cavity Capacity (cu. ft.)	3.1 cu. ft.
Holds Up To __ Dinner Plates	32

TECHNICAL DETAILS

Watts (W)	1,080 W
Circuit Breaker (A)	15 A
Volts (V)	120 V
Frequency (Hz)	60 Hz
Power Cord Length (in)	72"
Plug Type	120V 3-Wire

DIMENSIONS & WEIGHT

Overall Appliance Dimensions (HxWxD) (in)	9 7/8" x 33 9/16" x 21 3/4"
Required Cutout Size (HxWxD) (in)	10" x 34 1/2" x 23"
Net Weight (lbs)	75 lbs

WARRANTY

Limited Warranty Parts and Labor	2 Year
----------------------------------	--------

WARMING DRAWERS

PLANNING INFORMATION

MODEL OPTIONS

Thermador Warming Drawers are available in 27-inch, 30-inch and 36-inch widths to fit your kitchen plans perfectly. There are two series to choose from—Professional and Masterpiece®. Each series features a distinctive style. You may choose from traditional warming drawers or convection warming drawers. The warming drawers featured in this guide include the front panel—you no longer need to purchase front panels separately. Additionally, Thermador Convection Warming Drawer units may be installed with your own custom front panel and are available with Masterpiece® or Professional handles. Be sure to reference the correct model information in this design guide.

INSTALLATION CONSIDERATIONS

The information in this design guide provides key features, product dimensions, cutouts and installation specifications. Before installing a Thermador Warming Drawer, be sure to verify the cabinet dimensions and electrical connections. Also, always consult with the installation manual packed with the product for complete details before installing.

ELECTRICAL SPECIFICATIONS

Be sure your appliance is properly installed and grounded by a qualified technician. Installation, electrical connections and grounding must comply with all applicable local codes.

All Thermador Warming Drawers are designed to be connected to a 120V AC, 60 Hz, 3-wire, grounded outlet with a 15 A circuit breaker.

ELECTRICAL LOCATION

The outlet can be installed in the back wall directly behind the drawer.

INSTALLATION OPTIONS

WALL-MOUNTED INSTALLATION

Thermador Warming Drawers may be installed below any Thermador Single or Double Built-in Oven. A minimum space of 1" is recommended between the bottom of the oven and the top of the warming drawer. Refer to the built-in oven section for additional details.

UNDER-COUNTER INSTALLATION

Thermador Warming Drawers may also be installed below any Thermador Electric or Non-professional Gas Cooktop as long as there is no contact between the bottom of the cooktop and the top of the warming drawer. When installing below a Thermador Induction Cooktop, a minimum 1" air gap must be maintained between the bottom of the cooktop and the top of the warming drawer. When installing below a Thermador Professional® Rangetop, a minimum 2 3/4" air gap must be maintained between the bottom of the cooktop and the top of the warming drawer. Refer to the appropriate cooktop or rangetop section for additional details.

The cabinet base must be flat and capable of supporting a weight of at least 110 lbs. (50 kg).

WDC30J, WDC36J CUSTOM FRONT PANEL

These Thermador Warming Drawers require a custom front panel. You may build a custom drawer front panel to coordinate with your cabinetry. Custom panels must meet the following requirements:

- Have a handle
- Have the dimensions shown below
- Have a minimum thickness of 3/4" (19 mm)
- Have all edges finished
- Be capable of withstanding a temperature of 158°F (70° C)

WARMING DRAWERS

INSTALLATION

27-INCH TRADITIONAL WARMING DRAWER AND CUTOUT DIMENSIONS

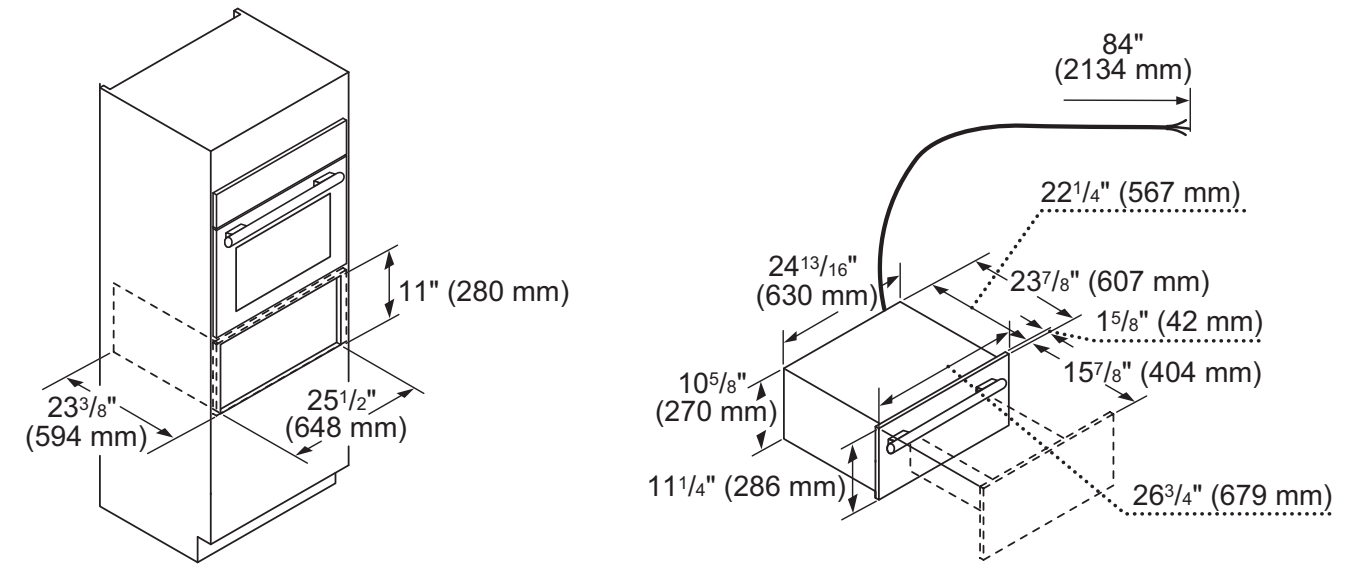

30-INCH TRADITIONAL WARMING DRAWER AND CUTOUT DIMENSIONS

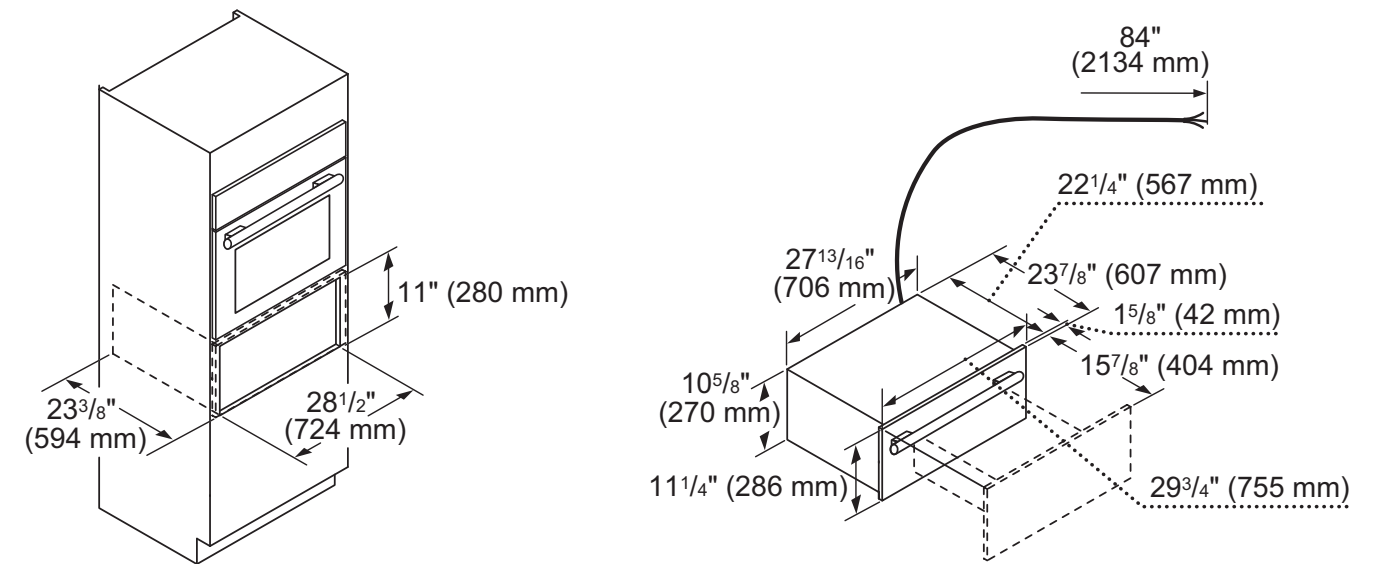

Door Handle Depth*

Masterpiece
Handle

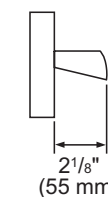

*Protrusion of handle from outer part of drawer front. Does not include thickness of drawer front

Door Handle Depth*

Professional
Handle

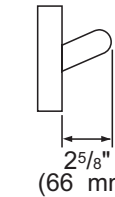

*Protrusion of handle from outer part of drawer front. Does not include thickness of drawer front

WARMING DRAWERS INSTALLATION

30-INCH CONVECTION WARMING DRAWER AND CUTOUT DIMENSIONS

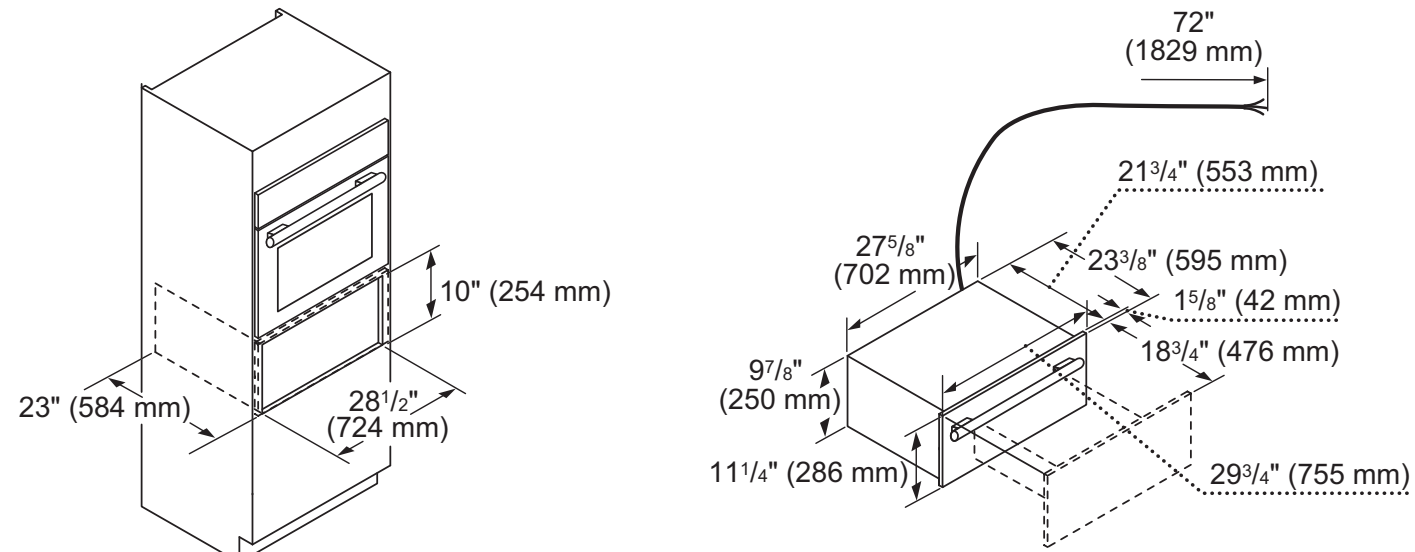

NOTE: 1 5/8" is the depth of the standard front panel (includes gasket). Dimension is not valid for custom panel product.

WARMING DRAWERS INSTALLATION

36-INCH CONVECTION WARMING DRAWER AND CUTOUT DIMENSIONS

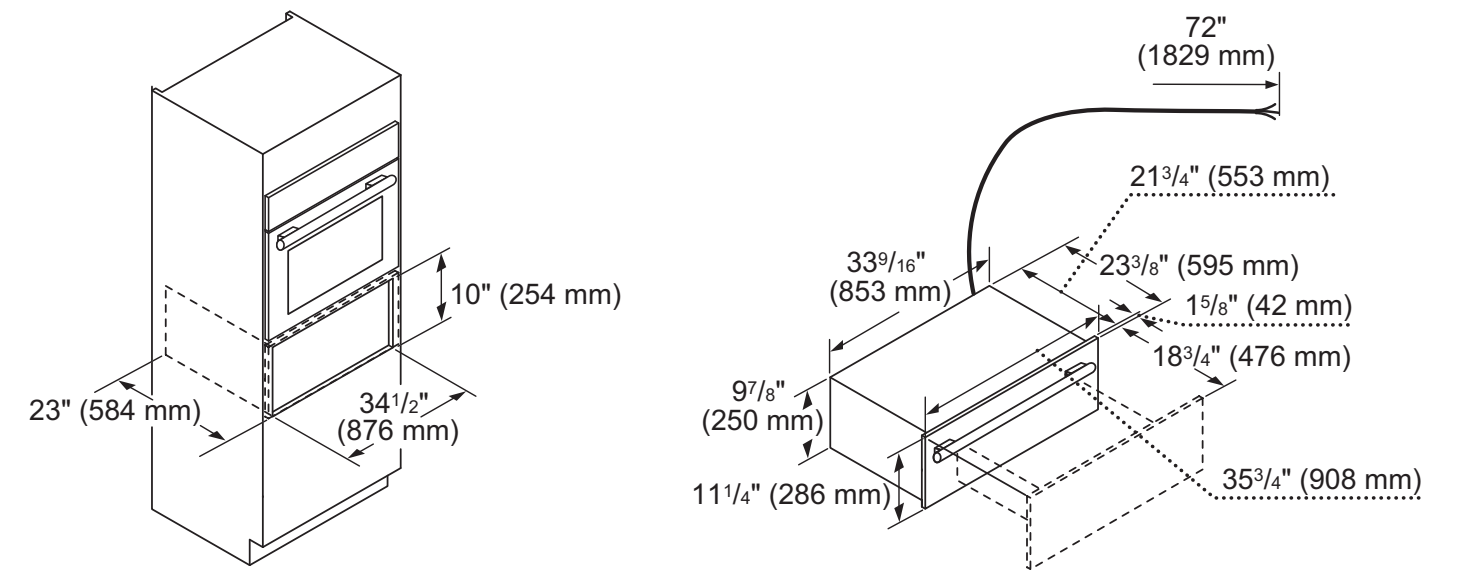

NOTE: 1 5/8" is the depth of the standard front panel (includes gasket). Dimension is not valid for custom panel product.

30-INCH CONVECTION WARMING DRAWER CUSTOM PANEL DIMENSIONS

Build custom drawer front to the dimensions specified below. All four edges must be finished. If using wood, the back must be sealed to prevent moisture damage.

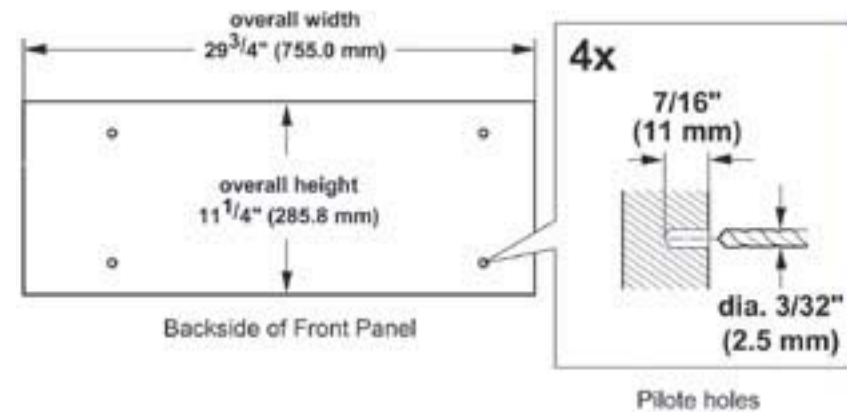

Door Handle Depth*

Masterpiece Handle

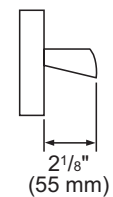

*Protrusion of handle from outer part of drawer front. Does not include thickness of drawer front

Door Handle Depth*

Professional Handle

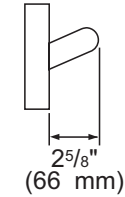

*Protrusion of handle from outer part of drawer front. Does not include thickness of drawer front

36-INCH CONVECTION WARMING DRAWER CUSTOM PANEL DIMENSIONS

Build custom drawer front to the dimensions specified below. All four edges must be finished. If using wood, the back must be sealed to prevent moisture damage.

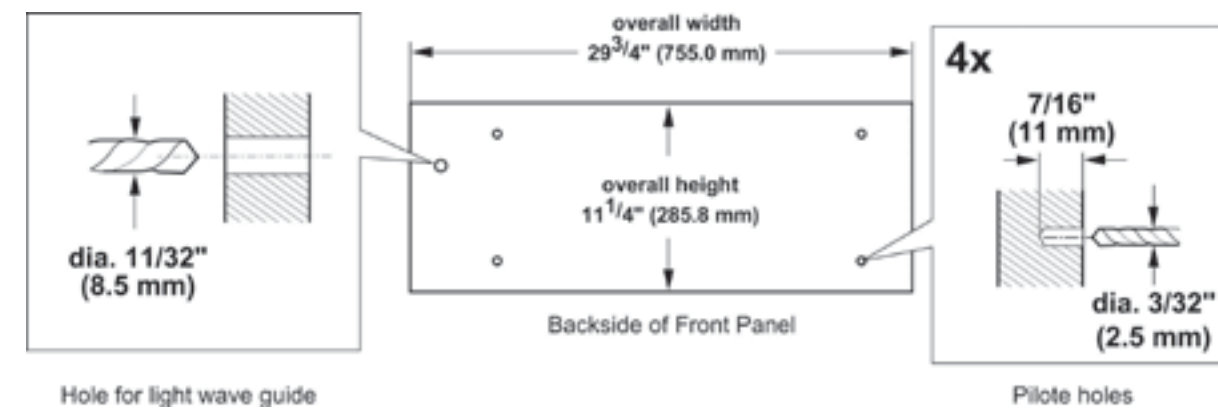

Door Handle Depth*

Professional Handle

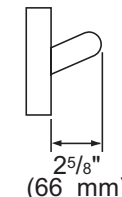



Thermador 

BUILT-IN MICROWAVES

PROFESSIONAL & MASTERPIECE® SERIES

The Thermador® Built-In MicroDrawer® Microwave combines luxury-class cooking power with industry-leading innovations. With a spacious 1.2 cubic foot capacity and 950 Watts of power, it can be conveniently installed below a countertop for easy access. The exclusive design makes it the only model that can be installed perfectly flush in any standard depth cabinetry.

Thermador Traditional and Convection Built-In Microwaves bring practicality and elegance to your kitchen with 10 power levels and sensor cooking. And to perfectly integrate these models into your kitchen, we offer a handsome 27-inch and 30-inch stainless steel trim kit.



Features That Inspire REAL COOKS TO CREATE

BUILT-IN MICRODRAWER® MICROWAVE

★ LARGE CAPACITY

Our Built-In MicroDrawer® Microwave features a 1.2 cubic foot capacity. The drawer is tall enough to hold a 20 oz. cup and large enough to contain a 9-inch by 13-inch casserole dish.

★ FLUSH INSTALLATION

The Built-In MicroDrawer® Microwave is the only drawer that can be installed perfectly flush in any standard depth cabinetry while providing superior access and ease of use, with the appliance placed at a convenient height.

★ SENSOR COOKING

Auto cooking modes, including melt, warm and soften, help culinary enthusiasts achieve perfect results. Our Built-In MicroDrawer® Microwave also includes a special sensor mode that detects moisture and automatically adjusts cooking level and time to take the guesswork out of cooking and reheating.

TOUCH "OPEN" AND "CLOSE"

Incorporating a sleek, uncluttered design, the Built-In MicroDrawer® Microwave opens and closes with a simple touch, eliminating the need for a handle.

TRADITIONAL AND CONVECTION MICROWAVES

CONVECTION TECHNOLOGY

Thermador Convection Microwaves feature convection technology that circulates hot air within the unit so foods cook faster and more evenly without any loss of flavor.

SENSOR COOKING

The microwave oven uses humidity sensing to achieve perfect results with minimal user programming.

10 POWER LEVELS

When microwaving, enjoy the ultimate in control and flexibility for perfect results every time.

KEEP WARM

Keep food warm for up to 30 minutes after cooking.

QUICK DEFROST

Defrost foods such as meat, poultry and seafood simply by entering the weight.

★ THERMADOR® EXCLUSIVE

MD24JS 24-INCH MICRODRAWER® MICROWAVE MASTERPIECE® & PROFESSIONAL SERIES

Thermador★



FEATURES & BENEFITS

- Spacious 1.2 cu. ft. Interior fits a 20 oz. cup or a 13" x 9" pan
- 950 watts microwave power and 10 power levels
- Sensor cooking programs measure humidity and adjust cooking level and cooking time
- Touch "open" and "close"
- Perfect flush installation and hidden vent

GENERAL PROPERTIES

Cavity Color	White
Max. Microwave Power (W)	950 W

CAPACITY

Cavity Capacity (cu. ft.)	1.2 cu. ft.
Turntable Diameter (in.)	N/A

TECHNICAL DETAILS

Watts (W)	1,500 W
Circuit Breaker (A)	15 A
Volts (V)	120 V
Frequency (Hz)	60 Hz
Plug Type	120V-3 Prong
Power Cord Length (in.)	48"

DIMENSIONS & WEIGHT

Overall Appliance Dimensions (HxWxD) (in.)	16 5/16" x 23 7/8" x 23 3/8"
Required Cutout Size (HxWxD) (in.)	14 13/16" x 22 1/8" x 23 1/2"
Net Weight (Lbs)	81 lbs

ACCESSORIES (INCLUDED)

N/A

WARRANTY

Limited Warranty, Entire Appliance, Parts and Labor	2 Year
---	--------

MD30RS
30-INCH MICRODRAWER® MICROWAVE
 MASTERPIECE® & PROFESSIONAL SERIES



FEATURES & BENEFITS

- A spacious 1.2 cu. ft. interior fits a 20 oz. cup or a 13" x 9" pan
- Achieve a perfectly flush installation in any standard depth cabinetry
- Our MicroDrawer® includes a special sensor mode that controls humidity and automatically adjusts cooking level and time
- 10 cooking modes that include melt, warm and soften
- Touch "open" and "close" eliminates the need for a handle

GENERAL PROPERTIES	
Cavity Color	White
Max. Microwave Power (W)	950 W
CAPACITY	
Cavity Capacity (cu. ft.)	1.2 cu. ft.
TECHNICAL DETAILS	
Watts (W)	1,500 W
Circuit Breaker (A)	15 A
Volts (V)	120 V
Frequency (Hz)	60 Hz
Plug Type	120V-3 prong
Power Cord Length (In)	48"
DIMENSIONS & WEIGHT	
Overall Appliance Dimensions (HxWxD) (In)	16 5/16" x 30" x 23 3/8"
Required Cutout Size (HxWxD) (in.)	14 13/16" x 28 1/4" x 23 1/2"
Net Weight (Lbs)	82 lbs
WARRANTY	
Limited Warranty, Entire Appliance, Parts and Labor	2 Year

MBES
BUILT-IN MICROWAVE
 MASTERPIECE® & PROFESSIONAL SERIES



FEATURES & BENEFITS

- Innovative microwave inverter technology offers consistent cooking performance
- 1,200 watts microwave power and 10 microwave power levels
- Automatic beverages reheat—determines cooking level and time
- Sensor cooking programs measure humidity and adjust cooking level and cooking time
- Built-in microwave is the perfect companion for any Thermador wall oven

ACCESSORIES (OPTIONAL)



MBT27JS
27-Inch Trim Kit



MBT30JS
30-Inch Trim Kit

GENERAL PROPERTIES	
Cavity Color	White
Max. Microwave Power (W)	1,200 W
CAPACITY	
Cavity Capacity (cu. ft.)	2.1 cu. ft.
Turntable Diameter (in.)	16 1/2"
TECHNICAL DETAILS	
Watts (W)	1,460 W
Circuit Breaker (A)	20 A
Volts (V)	120 V
Frequency (Hz)	60 Hz
Plug Type	120V-3 Prong
Power Cord Length (in.)	41 5/16"
DIMENSIONS & WEIGHT	
Overall Appliance Dimensions (HxWxD) (in.)	14" x 23 7/8" x 19 7/16"
27" Trim Kit Required Cutout Size (HxWxD) (in.)	19 7/8" x 25 7/16" x 21"
30" Trim Kit Required Cutout Size (HxWxD) (in.)	19 7/8" x 28 7/16" x 21"
Net Weight (Lbs)	34 lbs
ACCESSORIES (INCLUDED)	
1 Ceramic Glass Tray, 1 Roller Ring	
WARRANTY	
Limited Warranty, Entire Appliance, Parts and Labor	2 Year

MCES

BUILT-IN MICROWAVE WITH CONVECTION

MASTERPIECE® & PROFESSIONAL SERIES



FEATURES & BENEFITS

- Automatic convection bake programs
- Innovative microwave inverter technology offers consistent cooking performance
- 1,000 watts microwave power and 10 microwave power levels
- Sensor cooking programs measure humidity and adjust cooking level and cooking time
- Built-in convection microwave is the perfect companion for any Thermador wall oven

ACCESSORIES (OPTIONAL)



MCT27JS
27-Inch Trim Kit



MCT30JS
30-Inch Trim Kit

GENERAL PROPERTIES	
Cavity Color	Stainless Steel
Max. Microwave Power (W)	1,000 W
CAPACITY	
Cavity Capacity (cu. ft.)	1.5 cu. ft.
Turntable Diameter (in.)	15"
TECHNICAL DETAILS	
Watts (W)	1,500 W
Circuit Breaker (A)	20 A
Volts (V)	120 V
Frequency (Hz)	60 Hz
Plug Type	120V-3 Prong
Power Cord Length (in.)	41 5/16"
DIMENSIONS & WEIGHT	
Overall Appliance Dimensions (HxWxD) (in.)	14 13/16" x 23 7/8" x 19 5/16"
27" Trim Kit Required Cutout Size (HxWxD) (in.)	19 7/8" x 25 7/16" x 21"
30" Trim Kit Required Cutout Size (HxWxD) (in.)	19 7/8" x 28 7/16" x 21"
Net Weight (Lbs)	33 lbs
ACCESSORIES (INCLUDED)	
1 Oven Rack, 1 Ceramic Glass Tray, 1 Roller Ring	
WARRANTY	
Limited Warranty, Entire Appliance, Parts and Labor	2 Year

MODEL OPTIONS

There are two Thermador Built-in Microwaves to choose from—traditional and convection. 27-inch and 30-inch stainless steel trim kits must be used and are available for each.

You can also choose a Thermador 24-inch or 30-inch Built-in MicroDrawer® Microwave.

INSTALLATION CONSIDERATIONS

The information in this design guide provides key features, product dimensions, cutouts and installation specifications. Before installing a Thermador Microwave oven, be sure to verify the cabinet dimensions and electrical connections. Also, always consult the installation manual packed with the product for complete details before installing.

It is the responsibility of the owner and the installer to determine if additional requirements and / or standards apply to specific installations.

Do not block air vents. If they are blocked during operation, the oven may be overheated and damaged. If the oven overheats, a thermal safety device will turn the oven off. The oven will remain inoperable until it has cooled.

Do not place the microwave near a hot, damp surface such as a gas or electric range, dishwasher, or in an excessively humid room.

INSTALLATION OPTIONS

MBES / MCES MODELS

Thermador MCES / MBES Microwaves may be installed into a cabinet or wall as a standalone unit or above any Thermador Built-in Oven. They may also be installed above any Thermador Warming Drawer.

To reduce the risk of fire and electric shock, install microwave at least 3/4" above designated oven or warming drawer.

IMPORTANT: MCES and MBES models must be used in conjunction with a 27-inch or 30-inch microwave trim kit.

MICRODRAWER® MICROWAVE

The Thermador MicroDrawer® Microwave can be built into a cabinet or wall as a standalone unit or under a Thermador Built-in Oven.

Check to be sure that there is a clearance of 2" or greater between the top of the MicroDrawer® Microwave and the bottom of a built-in wall oven above it.

BUILT-IN MICROWAVES

PLANNING INFORMATION

ELECTRICAL SPECIFICATIONS

The microwave oven must be on a separate circuit. No other appliance should share the circuit with the microwave oven. If it does, the branch circuit fuse may blow or the circuit breaker may trip, or the food may cook slower than recommended.

This appliance must be grounded. It is equipped with a cord having a grounding wire with a grounding plug. The plug must be plugged into at least a 20 Amp, 120 Volt, 60 Hz 3-wire, grounded outlet that is properly installed.

The voltage used must be the same as specified on this microwave oven (120V, 60Hz). Using a higher voltage is dangerous and may result in a fire or oven damage. Using a lower voltage will cause slow cooking.

Do not use an extension cord. If the power supply cord is too short, have a qualified electrician or serviceman install an outlet near the appliance.

MODEL	REQUIRED CIRCUIT BREAKER
	240V, 60 Hz
MBES	20 A
MCES	20 A
MD24JS	15 A
MD30RS	15 A

BUILT-IN MICROWAVES INSTALLATION

24-INCH MICRODRAWER® MICROWAVE AND CUTOUT DIMENSIONS

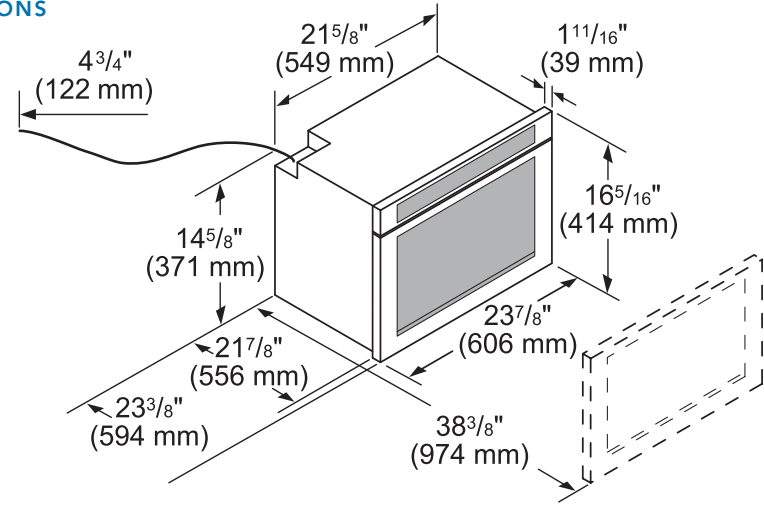

24-INCH MICRODRAWER® MICROWAVE STANDARD INSTALLATION

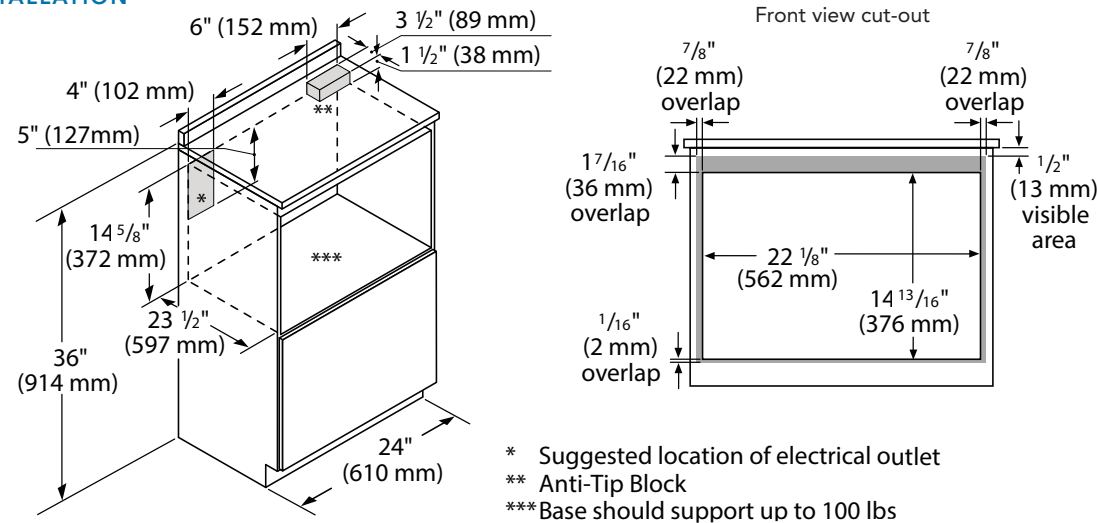

- * Suggested location of electrical outlet
- ** Anti-Tip Block
- *** Base should support up to 100 lbs

24-INCH MICRODRAWER® MICROWAVE FLUSH INSTALLATION

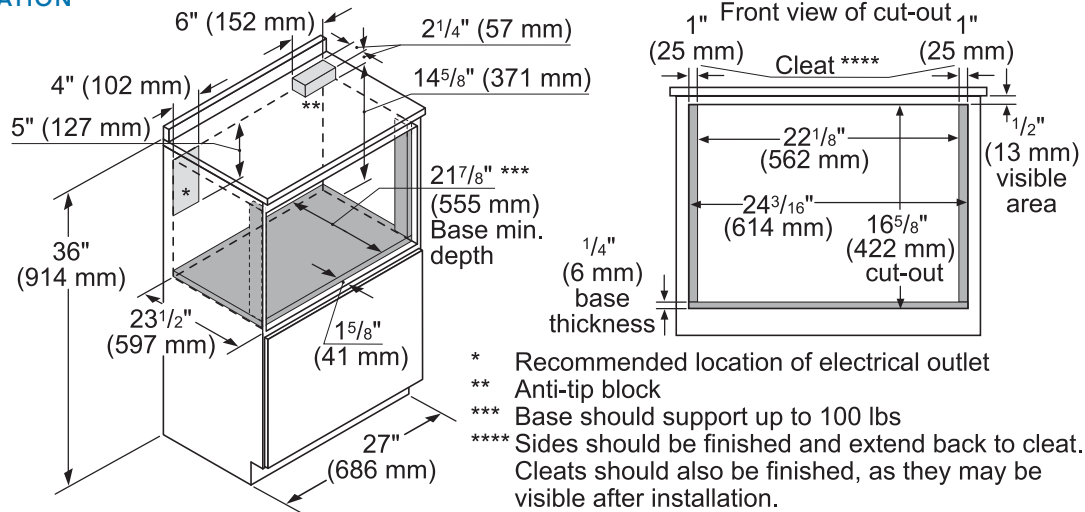

- * Recommended location of electrical outlet
- ** Anti-tip block
- *** Base should support up to 100 lbs
- **** Sides should be finished and extend back to cleat. Cleats should also be finished, as they may be visible after installation.

BUILT-IN MICROWAVES INSTALLATION

30-INCH MICRODRAWER® MICROWAVE AND CUTOUT DIMENSIONS

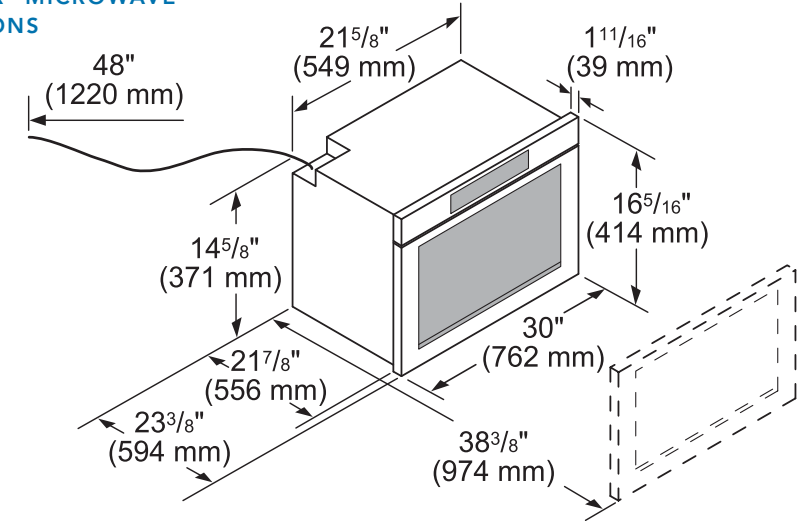

30-INCH MICRODRAWER® MICROWAVE STANDARD INSTALLATION

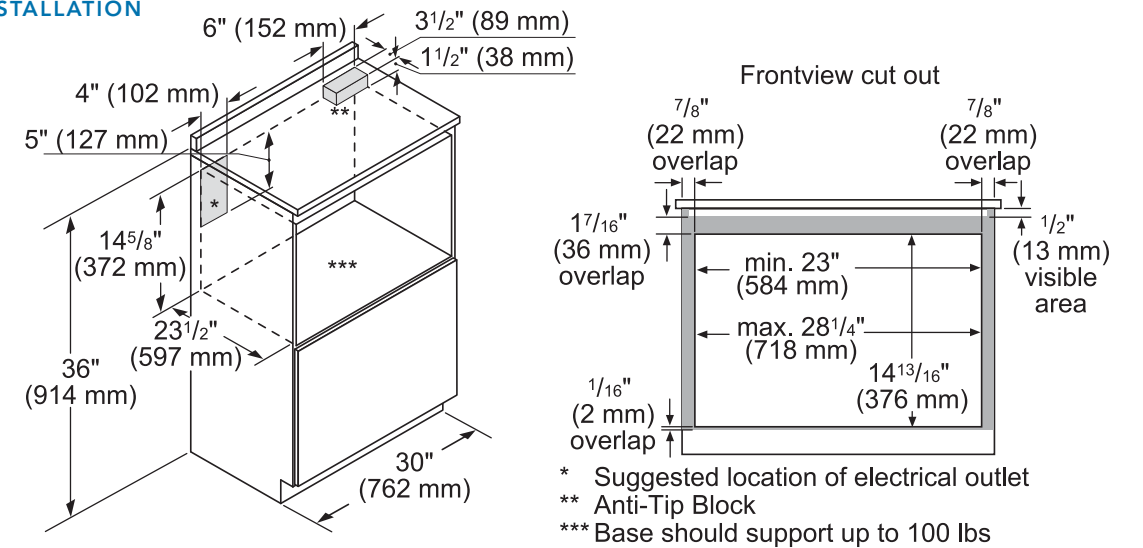

- * Suggested location of electrical outlet
- ** Anti-Tip Block
- *** Base should support up to 100 lbs

30-INCH MICRODRAWER® MICROWAVE FLUSH INSTALLATION

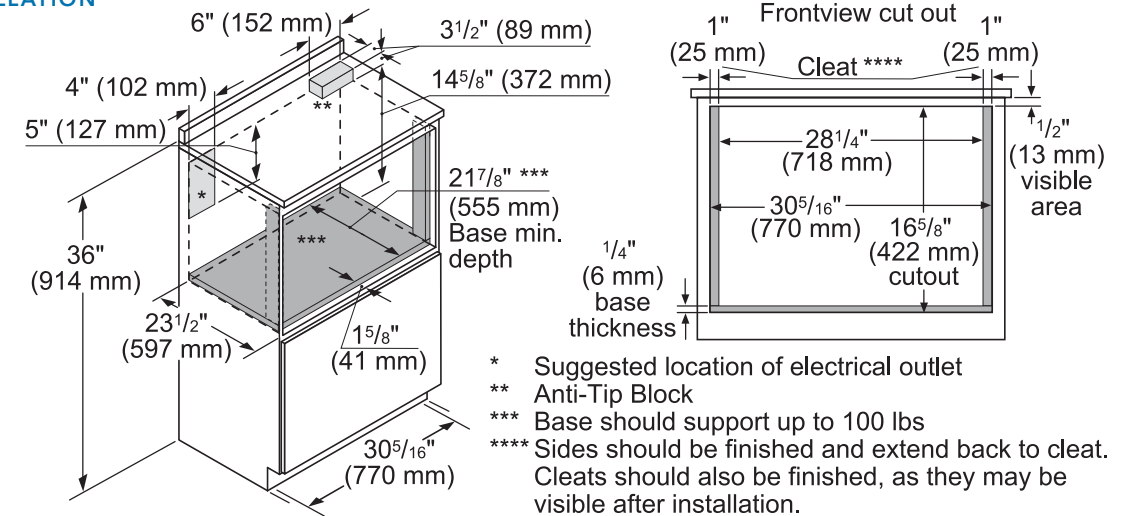

- * Suggested location of electrical outlet
- ** Anti-Tip Block
- *** Base should support up to 100 lbs
- **** Sides should be finished and extend back to cleat. Cleats should also be finished, as they may be visible after installation.

BUILT-IN MICROWAVES INSTALLATION

TRADITIONAL BUILT-IN MICROWAVE OVEN DIMENSIONS

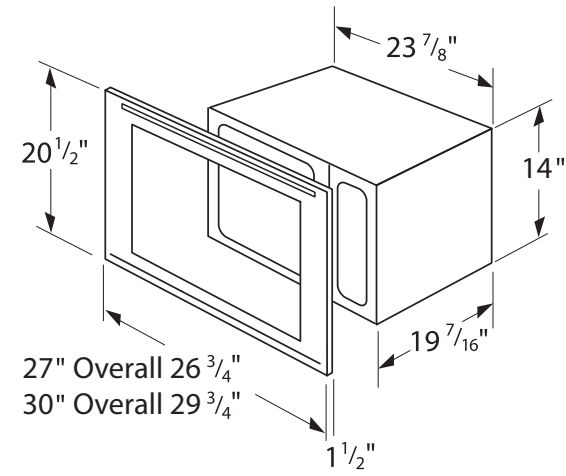

CONVECTION BUILT-IN MICROWAVE OVEN DIMENSIONS

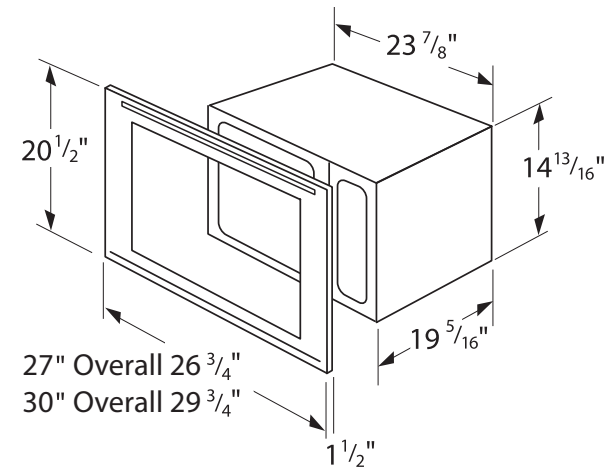

BUILT-IN MICROWAVE OVEN CUTOUT DIMENSIONS

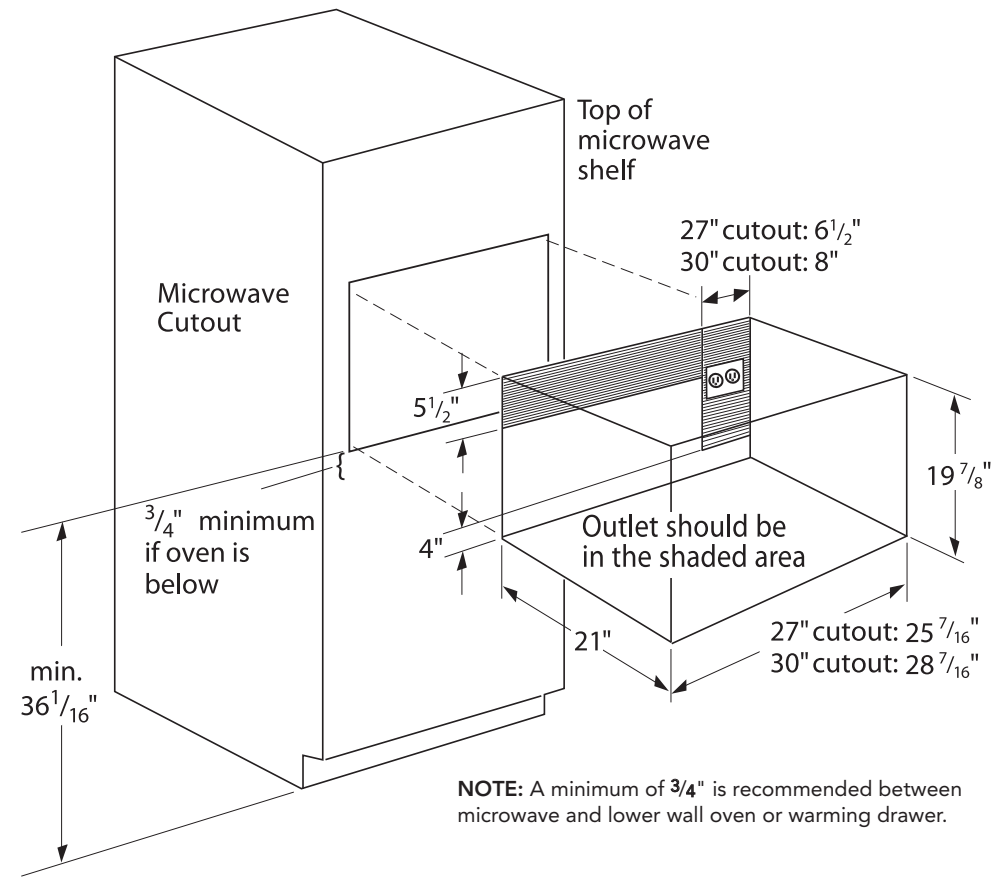

MODELS SHOWN: MES301HS BUILT-IN STEAM AND CONVECTION OVEN OVER ME301JS SINGLE BUILT-IN OVEN, AND MD24JS MICRODRAWER® MICROWAVE. KITCHEN DESIGN BY: THOMAS TRZCINSKI, KITCHEN & BATH CONCEPTS OF PITTSBURGH, LLC



REFRIGERATION

FREEDOM® COLLECTION

Preserve every incredible moment in your culinary adventures with the New Freedom® Refrigeration Collection. Taking personalization to a new level, the Fresh Food, Freezer, and Wine collection introduces new custom exterior and interior features, meticulously crafted to let you flavor life the way you like it.

Our portfolio of custom panel models—available in 18-inch, 23.5-inch, 30-inch and 36-inch widths—offers the most design choices in the industry, allowing you to configure your own unique combination of bottom freezers, fresh food, freezer and wine preservation columns. And nothing beats the convenience of our pre-assembled bottom freezers, ready to install straight from the factory. Equipped with flat stainless steel panels and either Professional or Masterpiece® Handles set off by a removable stainless steel frame, these units deliver perfect built-in fit and aesthetics in a 24-inch or 25-inch deep cabinet.





Freedom® Collection COMMON FEATURES

★ COOL AIR FLOW TECHNOLOGY

Thermador refrigerators and freezers have never been more energy efficient. Cool Air Flow—upgraded with a new, quieter fan—is proprietary Thermador technology that optimizes and evenly distributes cold air throughout all parts of the unit.

★ OPEN DOOR ASSIST (NEW)

With the flexibility to either push or pull to open, new Thermador Auto Door Opening technology adds a luxurious touch as well as an option for a sleek, handleless design.

★ TFT DISPLAY (NEW)

A touch-screen TFT display panel controls settings, including individual temperature control, lighting and Open Door Assist.

★ THEATER LIGHTING (NEW)

See your ingredients in a new light. Theater-style, diffused lighting, ensures visibility while limiting hot spots.

★ SOFT-CLOSE DRAWERS (NEW)

Luxury you can feel. Revel in a gentle, quiet glide when you open or close interior drawers.

★ ALL-LEG LEVELING (NEW)

New all-leg leveling allows for quicker and faster installation.

★ DUAL EVAPORATOR & DUAL COMPRESSOR SYSTEMS

Each cooling compartment in our bottom freezer units—refrigerator and freezer—has its own evaporator and compressor to eliminate odor transfer and keep food fresher, longer, with better humidity and air flow.



Freedom® Collection FRESH FOOD COLUMN

★ THERMAFRESH SYSTEM (NEW)

Controlled independently, the ThermaFresh System provides humidity control and temperature management where you need it most.

★ DELICATE PRODUCE BINS (NEW)

Avoid bruised produce and damaged herbs. Store your fresh-from-the-garden fruits and vegetables in luxury with removable Soft-Close Delicate Produce Bins.

★ FREE FLOW® COLD AIR SYSTEM

Free Flow Cold Air System adjusts the temperature of refrigeration doors to help keep items placed on interior shelves cool.

★ REDESIGNED HALF-GALLON BINS (NEW)

An all-new railing system offers a variety of placement options on the refrigerator door for redesigned half-gallon bins.

★ 23.5-INCH PRECISE FIT REFRIGERATION (NEW)

Specially designed 23.5" refrigeration is made for pairing with 18" and 24" freezer units to accommodate predetermined 42" and 48" spaces.

★ 36-INCH REFRIGERATOR COLUMN (NEW)

With the new 36" Refrigerator Column, running out of room is not an option. Ample door space allows for personalized interior storage, helping you take your culinary creativity to new heights.

★ THERMADOR® EXCLUSIVE



Completely Customizable INSIDE AND OUT

Featuring first-of-its-kind innovation, the Thermador Freedom® Refrigeration Collection is completely customizable, both outside and in. Whether storing fresh herbs and produce from the farmer's market, or pickled vegetables and homemade jams, newly designed shelving and Delicate Produce Bins can be configured to suit your culinary lifestyle.



Farmer's Market Enthusiast

Stock up on locally grown ingredients with the ideal setup for fresh herbs, fruits, vegetables, and pressed juices.

36" FRENCH DOOR



30" BOTTOM FREEZER



24" SINGLE COLUMN



Daily Chef

Not sure where to start? All Thermador refrigerators include a configuration designed to fit a wide range of uses.

36" FRENCH DOOR



30" BOTTOM FREEZER



24" SINGLE COLUMN



Preservationist

The perfect setup for homemade jams, jellies, and pickled vegetables. Keep your creations fresh with plenty of door shelf space for finished jars.

36" FRENCH DOOR



30" BOTTOM FREEZER



24" SINGLE COLUMN



Colder and BOLDER

From preserving homemade soups and sauces to providing ice that gives beverages signature flair, redesigned Thermador Freezers are built to stand up to the needs of any exceptional cook. With a new bin design, theater lighting for improved visibility, Soft-Close drawers and unique Diamond Ice, Thermador Freezers ensure you never get left out of the cold.



Freedom® Collection FREEZER COLUMN

★ DIAMOND ICE

An eye-catching addition to any party, Thermador Diamond Ice features a unique shape that keeps drinks cold. Use Diamond Ice in your favorite craft cocktails to make a lasting impression.

★ SUPERFREEZE®

Get cooler, faster. Whether you're just returning from the market or freezing for future use, Super Freeze brings food to its ideal preservation temperature after placing it in the freezer.

IN-DOOR DISPENSER

With intuitive touch controls and completely integrated installation, the Thermador In-Door Ice and Water Dispenser is sleeker than ever. Proximity Sensor and stunning lighting make for a captivating filtered water solution.

FULL-WIDTH ICE DRAWERS

Full-width ice drawers have the capacity to hold more ice to help prepare for larger gatherings.

36-INCH FREEZER COLUMN (NEW)

With the new 36" Freezer Column, ample interior space lets you preserve every incredible moment in your culinary adventures.

★ THERMADOR® EXCLUSIVE



*Leave no
pour less than*
PERFECT

Collect. Display. Share. And with exceptional storage, enjoy. An absolute must for wine connoisseurs, Thermador Wine Columns can hold up to 98 bottles and offer up to three zones to ensure your wines are stored at the optimum temperature and humidity. Diamond-shaped wooden dowels cradle each bottle, while a Presenter Shelf puts your favorites on display. Whether you're hosting a large gathering or simply enjoying a glass of wine at the end of the day, Thermador Wine Columns make every sip exceptional.

Freedom® Collection
WINE PRESERVATION

★ **PRESENTER SHELF**

Let your favorite bottles catch the eye. A newly designed Presenter Shelf made of Wenge wood and aluminum boasts a stylish design allowing you to place your favorite wines front and center.

★ **DIAMOND DOWELS**

Unique, diamond-shaped wooden dowels help control wine sediment by cradling bottles of every size for stability, as well as offer elegant presentation.

3-ZONE TEMPERATURE CONTROL

From Chardonnay to Pinot to Rosé, store all of your wines at the optimum temperature. The Thermador 24" Wine Column features UV glass and is equipped with three separate zones for individual temperature control.

HIDDEN RAILS

In these newly designed wine columns, the ball bearings and rails are completely out of sight. All you can see—and feel—is luxury.

★ **THERMADOR® EXCLUSIVE**



THE NEXT GENERATION OF REFRIGERATION

When it comes to refrigeration, culinary enthusiasts want more than mere preservation. They want personalization. Thermador® Culinary Preservation Centers offer an amazing array of refrigerator, freezer and wine center combinations that allow for flexibility and customization in the kitchen. Combine a French door bottom freezer with a wine column. Make a dramatic statement with wine storage flanked by freezer and refrigerator columns. Today's affluent consumers are leaving yesteryear's semi-flush products for fully-flush, integrated refrigeration to achieve the design they envision. Culinary Preservation Centers offer configuration possibilities that are an exciting departure from the rigid conformity of side-by-side replacement options. Be inspired.

EXPERIENCE THE FREEDOM TO DO MORE WITH THERMADOR.



The Ultimate Culinary Preservation Centers EXCLUSIVE DETAILS



ULTIMATE ENTERTAINER

- 30-Inch Fresh Food
- 24-Inch Wine Column
- 30-Inch Fresh Food/Freezer

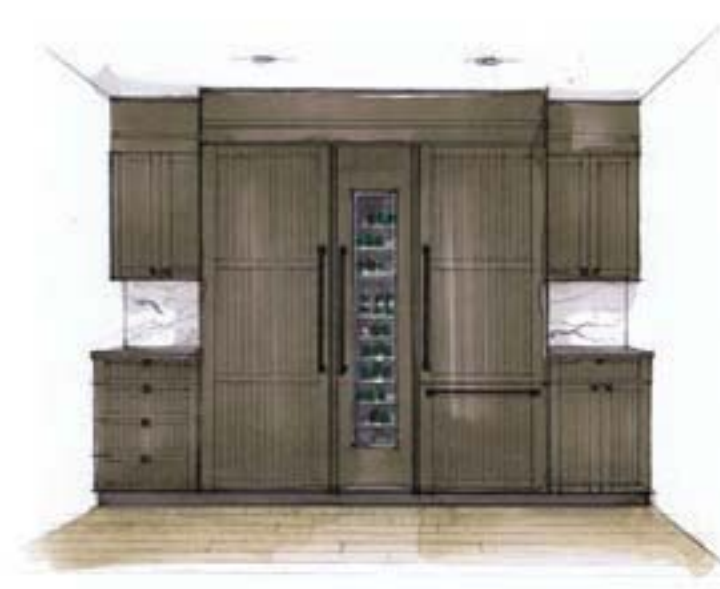

WEEKEND ENTERTAINER

- 30-Inch Fresh Food
- 18-Inch Wine Column
- 30-Inch Fresh Food/Freezer



SOCIAL ENTERTAINER

- 36-Inch French Door Fresh Food/Freezer
- 24-Inch Wine Column



CONTEMPORARY FAMILY

- 30-Inch Fresh Food
- 24-Inch Wine Column
- 36-Inch Fresh Food/Freezer



URBAN FAMILY

- 24-Inch Fresh Food
- 18-Inch Freezer



WEEKDAY ENTERTAINER

- 30-Inch Fresh Food
- 18-Inch Freezer



HOLIDAY ENTERTAINER

- 36-Inch Side-Swing Door Fresh Food/Freezer
- 24-Inch Wine Column



ORGANIC FAMILY

- 36-Inch French Door Fresh Food/Freezer
- 18-Inch Wine Column



MARKET FRESH ENTERTAINER

- 36-Inch Side-swing Door Fresh Food/Freezer
- 18-Inch Wine Column



EVERYDAY COOK

- 36-Inch French Door Fresh Food/Freezer



HEALTHY FAMILY

- 36-Inch Side-swing Door Fresh Food/Freezer

The Complete FREEDOM® COLLECTION

Newly redesigned in 2017, the Thermador Freedom Refrigeration Collection offers the ultimate in personalized preservation. Choose from a variety of sizes, standout stainless steel or custom paneling with options for a handleless, push-to-open design, as well as interior configuration options to store everything from delicate produce to jarred preserves.



BUILD YOUR OWN CUSTOM COLUMN

Our award winning Freedom Collection offers customized columns in four simple steps.

1. Choose your unit: Fresh Food, Freezer, Bottom Freezer or Wine Preservation Column.
2. Choose your panel: Flush for a fully integrated look, or custom panel for seamless integration with the rest of your cabinetry.



Flush Panel



Custom Panel

3. Choose your handle: Masterpiece Series, Professional Series, or custom handles. See page 375 for details.



Professional Series



Masterpiece Series



Professional Series - Classic



Masterpiece Series - Classic

4. Customize your interior with various storage options to fit your lifestyle, including produce railings and bins. See page 375 for details.

Visit Thermador.com for details on building your custom column.

T23IR900SP

23.5-INCH BUILT-IN FRESH FOOD COLUMN

FREEDOM® COLLECTION, PANEL-READY



GENERAL PROPERTIES	
Panel Ready	Yes
Reversible Door Swing	Yes
SoftClose® Drawers	Yes
Carbon Air Filter	Yes
Lighting	New Bar ALL LED Sidewall and Theater Lighting
Full Width Shelves	4
Adjustable Shelves	3
Shelf Material	Glass w/Aluminum Profile
Full Extension Drawers @ 115° Door Opening Angle	Yes
Full Extension Drawers @ 90° Door Opening Angle	Yes
Temperature and Humidity Controlled Drawer	1
General Use Drawer	1
Door Bins	2
Gallon Door Bins	1
Delicate Produce Bins	2 Small
Door Open Alarm	Yes
Open Door Assist	Yes
Special Modes	Sabbath, Economy, Vacation

CAPACITY	
Total Unit Gross Capacity (cu. ft.) – AHAM	13 cu. ft.
Refrigerator Gross Capacity (cu. ft.)	13 cu. ft.

PERFORMANCE	
Dedicated Evaporator & Compressor System	Yes
Freeflow® Cold Air System	Yes
SuperCool	Yes

TECHNICAL DETAILS	
Watts (W)	180 W
Current (A)	15 A
Volts (V)	120V-3 Prong
Frequency (Hz)	60 Hz
Power Cord Length (in.)	139
Plug Type	120V-3 Prong

DIMENSIONS & WEIGHT	
Appliance Dimensions (H x W x D) (in.)	83 3/4" x 23 1/4" x 24"
Required Cutout Size (H x W x D) (in.)	84" x 23 1/2" x 25"
Net / Gross Weight (lbs)	319 / 342 lbs

EFFICIENCY	
ENERGY STAR® Qualified	Yes
Annual Energy Consumption	281 kWh

*Height adjustable + / -1/2" (+ / -13 mm)

See page 375 for accessories.

T24IR900SP

24-INCH BUILT-IN FRESH FOOD COLUMN

FREEDOM® COLLECTION, PANEL-READY



GENERAL PROPERTIES	
Panel Ready	Yes
Reversible Door Swing	Yes
SoftClose® Drawers	Yes
Carbon Air Filter	Yes
Lighting	New Bar ALL LED Sidewall and Theater Lighting
Full Width Shelves	4
Adjustable Shelves	3
Shelf Material	Glass w/Aluminum Profile
Full Extension Drawers @ 115° Door Opening Angle	Yes
Full Extension Drawers @ 90° Door Opening Angle	Yes
Temperature and Humidity Controlled Drawer	1
General Use Drawer	1
Door Bins	2
Gallon Door Bins	1
Delicate Produce Bins	2 Small
Door Open Alarm	Yes
Open Door Assist	Yes
Special Modes	Sabbath, Economy, Vacation

CAPACITY	
Total Unit Gross Capacity (cu. ft.) – AHAM	13 cu. ft.
Refrigerator Gross Capacity (cu. ft.)	13 cu. ft.

PERFORMANCE	
Dedicated Evaporator & Compressor System	Yes
Freeflow® Cold Air System	Yes
SuperCool	Yes

TECHNICAL DETAILS	
Watts (W)	180 W
Current (A)	15 A
Volts (V)	120V-3 Prong
Frequency (Hz)	60 Hz
Power Cord Length (in.)	139
Plug Type	120V-3 Prong

DIMENSIONS & WEIGHT	
Appliance Dimensions (H x W x D) (in.)	83 3/4" x 23 3/4" x 24"
Required Cutout Size (H x W x D) (in.)	84" x 24" x 25"
Net / Gross Weight (lbs)	319 / 342 lbs

EFFICIENCY	
ENERGY STAR® Qualified	Yes
Annual Energy Consumption	264 kWh

*Height adjustable + / -1/2" (+ / -13 mm)

See page 375 for accessories.

T30IR900SP

30-INCH BUILT-IN FRESH FOOD COLUMN

FREEDOM® COLLECTION, PANEL-READY



GENERAL PROPERTIES	
Panel Ready	Yes
Reversible Door Swing	Yes
SoftClose® Drawers	Yes
Carbon Air Filter	Yes
Lighting	New Bar ALL LED Sidewall and Theater Lighting
Full Width Shelves	4
Adjustable Shelves	3
Shelf Material	Glass w/Aluminum Profile
Full Extension Drawers @ 115° Door Opening Angle	Yes
Full Extension Drawers @ 90° Door Opening Angle	Yes
Temperature and Humidity Controlled Drawer	1
General Use Drawer	1
Door Bins	2
Gallon Door Bins	1
Delicate Produce Bins	2 Large
Door Open Alarm	Yes
Open Door Assist	Yes
Special Modes	Sabbath, Economy, Vacation

CAPACITY	
Total Unit Gross Capacity (cu. ft.) – AHAM	16.8 cu. ft.
Refrigerator Gross Capacity (cu. ft.)	16.8 cu. ft.

PERFORMANCE	
Dedicated Evaporator & Compressor System	Yes
Freeflow® Cold Air System	Yes
SuperCool	Yes

TECHNICAL DETAILS	
Watts (W)	180 W
Current (A)	15 A
Volts (V)	120V-3 Prong
Frequency (Hz)	60 Hz
Power Cord Length (in.)	139
Plug Type	120V-3 Prong

DIMENSIONS & WEIGHT	
Appliance Dimensions (H x W x D) (in.)	83 3/4" x 29 3/4" x 24"
Required Cutout Size (H x W x D) (in.)	84" x 30" x 25"
Net / Gross Weight (lbs)	344 / 368 lbs

EFFICIENCY	
ENERGY STAR® Qualified	Yes
Annual Energy Consumption	289 kWh

*Height adjustable + / -1/2" (+ / -13 mm)

See page 375 for accessories.

T36IR900SP

36-INCH BUILT-IN FRESH FOOD COLUMN

FREEDOM® COLLECTION, PANEL-READY



GENERAL PROPERTIES	
Panel Ready	Yes
Reversible Door Swing	Yes
SoftClose® Drawers	Yes
Carbon Air Filter	Yes
Lighting	New Bar ALL LED Sidewall and Theater Lighting
Full Width Shelves	4
Adjustable Shelves	3
Shelf Material	Glass w/Aluminum Profile
Full Extension Drawers @ 115° Door Opening Angle	Yes
Full Extension Drawers @ 90° Door Opening Angle	Yes
Temperature and Humidity Controlled Drawer	1
General Use Drawer	1
Door Bins	2
Gallon Door Bins	1
Delicate Produce Bins	1 Small, 2 Large
Door Open Alarm	Yes
Open Door Assist	Yes
Special Modes	Sabbath, Economy, Vacation

CAPACITY	
Total Unit Gross Capacity (cu. ft.) – AHAM	20.6 cu. ft.
Refrigerator Gross Capacity (cu. ft.)	20.6 cu. ft.

PERFORMANCE	
Dedicated Evaporator & Compressor System	Yes
Freeflow® Cold Air System	Yes
SuperCool	Yes

TECHNICAL DETAILS	
Watts (W)	180 W
Current (A)	15 A
Volts (V)	120V-3 Prong
Frequency (Hz)	60 Hz
Power Cord Length (in.)	139
Plug Type	120V-3 Prong

DIMENSIONS & WEIGHT	
Appliance Dimensions (H x W x D) (in.)	83 3/4" x 35 3/4" x 24 3/4"
Required Cutout Size (H x W x D) (in.)	84" x 36" x 25"
Net / Gross Weight (lbs)	462 / 491 lbs

EFFICIENCY	
ENERGY STAR® Qualified	Yes
Annual Energy Consumption	313 kWh

*Height adjustable + / -1/2" (+ / -13 mm)

See page 375 for accessories.

T18ID900LP

18-INCH BUILT-IN FREEZER COLUMN WITH ICE & WATER DISPENSER

FREEDOM® COLLECTION, PANEL-READY, LEFT-HAND DOOR SWING



Also Available In:
T18ID900RP – Right-Hand Door Swing

GENERAL PROPERTIES	
Panel Ready	Yes
Reversible Door Swing	No
SoftClose® Drawers	Yes
Lighting	ALL LED Sidewall and Theater Lighting
Full Width Shelves	2
Adjustable Shelves	2
Freezer Shelves	4
Shelf Material	Glass w/Aluminum Profile
Full Extension Drawers @ 115° Door Opening Angle	Yes
General Use Drawer	2
Door Bins	0
External LED Proximity Sensor	Yes
Oversized Dispenser Opening	Yes
Chilled Water, Crushed and Cubed Ice	Yes
Rapid Water Replenishment System	Yes
Ice Maker with Diamond Ice System	Yes
Door Open Alarm	Yes
Open Door Assist	Yes
Special Modes	Sabbath, Economy, Vacation

CAPACITY	
Total Unit Gross Capacity (cu. ft.) – AHAM	7.8 cu. ft.
Freezer Gross Capacity (cu. ft.)	7.8 cu. ft.

PERFORMANCE	
Dedicated Evaporator & Compressor System	Yes
SuperFreeze®	Yes
Defrost Process	Frost-Free

TECHNICAL DETAILS	
Watts (W)	506W
Current (A)	15 A
Volts (V)	120V-3 Prong
Frequency (Hz)	60 Hz
Power Cord Length (in.)	139
Plug Type	120V-3 Prong

DIMENSIONS & WEIGHT	
Appliance Dimensions (H x W x D) (in.)	83 3/4" x 17 3/4" x 24"
Required Cutout Size (H x W x D) (in.)	84" x 18" x 25"
Net / Gross Weight (lbs)	287 / 307 lbs

EFFICIENCY	
ENERGY STAR® Qualified	Yes
Annual Energy Consumption	428 kWh

*Height adjustable + / -1/2" (+ / -13 mm)

See page 375 for accessories.

T18ID900RP

18-INCH BUILT-IN FREEZER COLUMN WITH ICE & WATER DISPENSER

FREEDOM® COLLECTION, PANEL-READY, RIGHT-HAND DOOR SWING



Also Available In:
T18ID900LP – Left-Hand Door Swing

GENERAL PROPERTIES	
Panel Ready	Yes
Reversible Door Swing	No
SoftClose® Drawers	Yes
Lighting	ALL LED Sidewall and Theater Lighting
Full Width Shelves	2
Adjustable Shelves	2
Freezer Shelves	4
Shelf Material	Glass w/Aluminum Profile
Full Extension Drawers @ 115° Door Opening Angle	Yes
General Use Drawer	2
Door Bins	0
External LED Proximity Sensor	Yes
Oversized Dispenser Opening	Yes
Chilled Water, Crushed and Cubed Ice	Yes
Rapid Water Replenishment System	Yes
Ice Maker with Diamond Ice System	Yes
Door Open Alarm	Yes
Open Door Assist	Yes
Special Modes	Sabbath, Economy, Vacation

CAPACITY	
Total Unit Gross Capacity (cu. ft.) – AHAM	7.8 cu. ft.
Freezer Gross Capacity (cu. ft.)	7.8 cu. ft.

PERFORMANCE	
Dedicated Evaporator & Compressor System	Yes
SuperFreeze®	Yes
Defrost Process	Frost-Free

TECHNICAL DETAILS	
Watts (W)	506W
Current (A)	15 A
Volts (V)	120V-3 Prong
Frequency (Hz)	60 Hz
Power Cord Length (in.)	139
Plug Type	120V-3 Prong

DIMENSIONS & WEIGHT	
Appliance Dimensions (H x W x D) (in.)	83 3/4" x 17 3/4" x 24"
Required Cutout Size (H x W x D) (in.)	84" x 18" x 25"
Net / Gross Weight (lbs)	287 / 307 lbs

EFFICIENCY	
ENERGY STAR® Qualified	Yes
Annual Energy Consumption	428 kWh

*Height adjustable + / -1/2" (+ / -13 mm)

See page 375 for accessories.

T24ID900LP

24-INCH BUILT-IN FREEZER COLUMN WITH ICE & WATER DISPENSER

FREEDOM® COLLECTION, PANEL-READY, LEFT-HAND DOOR SWING



Also Available In:
T24ID900RP – Right-Hand Door Swing

GENERAL PROPERTIES	
Panel Ready	Yes
Reversible Door Swing	No
SoftClose® Drawers	Yes
Lighting	ALL LED Sidewall and Theater Lighting
Full Width Shelves	2
Adjustable Shelves	2
Freezer Shelves	4
Shelf Material	Glass w/Aluminum Profile
Full Extension Drawers @ 115° Door Opening Angle	Yes
General Use Drawer	2
Door Bins	0
External LED Proximity Sensor	Yes
Oversized Dispenser Opening	Yes
Chilled Water, Crushed and Cubed Ice	Yes
Rapid Water Replenishment System	Yes
Ice Maker with Diamond Ice System	Yes
Door Open Alarm	Yes
Open Door Assist	Yes
Special Modes	Sabbath, Economy, Vacation

CAPACITY	
Total Unit Gross Capacity (cu. ft.) – AHAM	11.2 cu. ft.
Freezer Gross Capacity (cu. ft.)	11.2 cu. ft.

PERFORMANCE	
Dedicated Evaporator & Compressor System	Yes
SuperFreeze®	Yes
Defrost Process	Frost-Free

TECHNICAL DETAILS	
Watts (W)	565 W
Current (A)	15 A
Volts (V)	120V-3 Prong
Frequency (Hz)	60 Hz
Power Cord Length (in.)	139
Plug Type	120V-3 Prong

DIMENSIONS & WEIGHT	
Appliance Dimensions (H x W x D) (in.)	84"* x 23 3/4" x 24"
Required Cutout Size (H x W x D) (in.)	84" x 24" x 25"
Net / Gross Weight (lbs)	333 / 355 lbs

EFFICIENCY	
ENERGY STAR® Qualified	Yes
Annual Energy Consumption	457 kWh

*Height adjustable + / -1/2" (+ / -13 mm)

See page 375 for accessories.

T24ID900RP

24-INCH BUILT-IN FREEZER COLUMN WITH ICE & WATER DISPENSER

FREEDOM® COLLECTION, PANEL-READY, RIGHT-HAND DOOR SWING



Also Available In:
T24ID900LP – Left-Hand Door Swing

GENERAL PROPERTIES	
Panel Ready	Yes
Reversible Door Swing	No
SoftClose® Drawers	Yes
Lighting	ALL LED Sidewall and Theater Lighting
Full Width Shelves	2
Adjustable Shelves	2
Freezer Shelves	4
Shelf Material	Glass w/Aluminum Profile
Full Extension Drawers @ 115° Door Opening Angle	Yes
General Use Drawer	2
Door Bins	0
External LED Proximity Sensor	Yes
Oversized Dispenser Opening	Yes
Chilled Water, Crushed and Cubed Ice	Yes
Rapid Water Replenishment System	Yes
Ice Maker with Diamond Ice System	Yes
Door Open Alarm	Yes
Open Door Assist	Yes
Special Modes	Sabbath, Economy, Vacation

CAPACITY	
Total Unit Gross Capacity (cu. ft.) – AHAM	11.2 cu. ft.
Freezer Gross Capacity (cu. ft.)	11.2 cu. ft.

PERFORMANCE	
Dedicated Evaporator & Compressor System	Yes
SuperFreeze®	Yes
Defrost Process	Frost-Free

TECHNICAL DETAILS	
Watts (W)	565 W
Current (A)	15 A
Volts (V)	120V-3 Prong
Frequency (Hz)	60 Hz
Power Cord Length (in.)	139
Plug Type	120V-3 Prong

DIMENSIONS & WEIGHT	
Appliance Dimensions (H x W x D) (in.)	84"* x 23 3/4" x 24"
Required Cutout Size (H x W x D) (in.)	84" x 24" x 25"
Net / Gross Weight (lbs)	333 / 355 lbs

EFFICIENCY	
ENERGY STAR® Qualified	Yes
Annual Energy Consumption	457 kWh

*Height adjustable + / -1/2" (+ / -13 mm)

See page 375 for accessories.

T18IF900SP

18-INCH BUILT-IN FREEZER COLUMN WITH INTERNAL ICE MAKER

FREEDOM® COLLECTION, PANEL-READY



GENERAL PROPERTIES	
Panel Ready	Yes
Reversible Door Swing	Yes
SoftClose® Drawers	Yes
Lighting	ALL LED Sidewall and Theater Lighting
Full Width Shelves	3
Adjustable Shelves	3
Freezer Shelves	4
Shelf Material	Glass w/Aluminum Profile
Full Extension Drawers @ 115° Door Opening Angle	Yes
General Use Drawer	2
Door Bins	4
External LED Proximity Sensor	No
Oversized Dispenser Opening	No
Chilled Water, Crushed and Cubed Ice	No
Rapid Water Replenishment System	No
Ice Maker with Diamond Ice System	Yes
Door Open Alarm	Yes
Open Door Assist	Yes
Special Modes	Sabbath, Economy, Vacation

CAPACITY	
Total Unit Gross Capacity (cu. ft.) – AHAM	8.6 cu. ft.
Freezer Gross Capacity (cu. ft.)	8.6 cu. ft.

PERFORMANCE	
Dedicated Evaporator & Compressor System	Yes
SuperFreeze®	Yes
Defrost Process	Frost-Free

TECHNICAL DETAILS	
Watts (W)	504W
Current (A)	15 A
Volts (V)	120V-3 Prong
Frequency (Hz)	60 Hz
Power Cord Length (in.)	139
Plug Type	120V-3 Prong

DIMENSIONS & WEIGHT	
Appliance Dimensions (H x W x D) (in.)	83 3/4" x 17 3/4" x 24"
Required Cutout Size (H x W x D) (in.)	84" x 18" x 25"
Net / Gross Weight (lbs)	271 / 291 lbs

EFFICIENCY	
ENERGY STAR® Qualified	Yes
Annual Energy Consumption	418 kWh

*Height adjustable + / -1/2" (+ / -13 mm)

See page 375 for accessories.

T24IF900SP

24-INCH BUILT-IN FREEZER COLUMN WITH INTERNAL ICE MAKER

FREEDOM® COLLECTION, PANEL-READY



GENERAL PROPERTIES	
Panel Ready	Yes
Reversible Door Swing	Yes
SoftClose® Drawers	Yes
Lighting	ALL LED Sidewall and Theater Lighting
Full Width Shelves	3
Adjustable Shelves	3
Freezer Shelves	4
Shelf Material	Glass w/Aluminum Profile
Full Extension Drawers @ 115° Door Opening Angle	Yes
General Use Drawer	2
Door Bins	4
External LED Proximity Sensor	No
Oversized Dispenser Opening	No
Chilled Water, Crushed and Cubed Ice	No
Rapid Water Replenishment System	No
Ice Maker with Diamond Ice System	Yes
Door Open Alarm	Yes
Open Door Assist	Yes
Special Modes	Sabbath, Economy, Vacation

CAPACITY	
Total Unit Gross Capacity (cu. ft.) – AHAM	12.2 cu. ft.
Freezer Gross Capacity (cu. ft.)	12.2 cu. ft.

PERFORMANCE	
Dedicated Evaporator & Compressor System	Yes
SuperFreeze®	Yes
Defrost Process	Frost-Free

TECHNICAL DETAILS	
Watts (W)	444 W
Current (A)	15 A
Volts (V)	120V-3 Prong
Frequency (Hz)	60 Hz
Power Cord Length (in.)	139
Plug Type	120V-3 Prong

DIMENSIONS & WEIGHT	
Appliance Dimensions (H x W x D) (in.)	84" x 23 3/4" x 24"
Required Cutout Size (H x W x D) (in.)	84" x 24" x 25"
Net / Gross Weight (lbs)	319 / 341 lbs

EFFICIENCY	
ENERGY STAR® Qualified	Yes
Annual Energy Consumption	443 kWh

*Height adjustable + / -1/2" (+ / -13 mm)

See page 375 for accessories.

T30IF900SP

30-INCH BUILT-IN FREEZER COLUMN WITH INTERNAL ICE MAKER

FREEDOM® COLLECTION, PANEL-READY



GENERAL PROPERTIES	
Panel Ready	Yes
Reversible Door Swing	Yes
SoftClose® Drawers	Yes
Lighting	ALL LED Sidewall and Theater Lighting
Full Width Shelves	3
Adjustable Shelves	3
Freezer Shelves	4
Shelf Material	Glass w/Aluminum Profile
Full Extension Drawers @ 115° Door Opening Angle	Yes
General Use Drawer	2
Door Bins	4
External LED Proximity Sensor	No
Oversized Dispenser Opening	No
Chilled Water, Crushed and Cubed Ice	No
Rapid Water Replenishment System	No
Ice Maker with Diamond Ice System	Yes
Door Open Alarm	Yes
Open Door Assist	Yes
Special Modes	Sabbath, Economy, Vacation

CAPACITY	
Total Unit Gross Capacity (cu. ft.) – AHAM	15.8 cu. ft.
Freezer Gross Capacity (cu. ft.)	15.8 cu. ft.

PERFORMANCE	
Dedicated Evaporator & Compressor System	Yes
SuperFreeze®	Yes
Defrost Process	Frost-Free

TECHNICAL DETAILS	
Watts (W)	504 W
Current (A)	15 A
Volts (V)	120V-3 Prong
Frequency (Hz)	60 Hz
Power Cord Length (in.)	139
Plug Type	120V-3 Prong

DIMENSIONS & WEIGHT	
Appliance Dimensions (H x W x D) (in.)	84"* x 29 3/4" x 24"
Required Cutout Size (H x W x D) (in.)	84" x 30" x 25"
Net / Gross Weight (lbs)	362 / 387 lbs

EFFICIENCY	
ENERGY STAR® Qualified	Yes
Annual Energy Consumption	493 kWh

*Height adjustable + / -1/2" (+ / -13 mm)

See page 375 for accessories.

FEATURES & BENEFITS

- Freedom® Hinge enables true flush design
- The new Auto Door Opening provides the opening of the door with just a slight push or pull
- Delicate Produce Bins for expanded storage
- ThermaFresh System, Humidity and Temperature controlled drawers
- SoftClose® Drawers and Produce Bins for easy and controlled storage
- Sleek clean design for the perfect symmetry when paired with additional columns
- TFT control panel managing all your columns functions

TEMPERATURE RANGES

Freezer	-9°F (-23°C) to 7°F (14°C)
SuperFreeze®	-9°F (-23°C) for approximately 52 hours
Energy Saving (Economy) Mode	3°F (-16°C)

T36IF900SP

36-INCH BUILT-IN FREEZER COLUMN WITH INTERNAL ICE MAKER

FREEDOM® COLLECTION, PANEL-READY



GENERAL PROPERTIES	
Panel Ready	Yes
Reversible Door Swing	Yes
SoftClose® Drawers	Yes
Lighting	ALL LED Sidewall and Theater Lighting
Full Width Shelves	3
Adjustable Shelves	3
Freezer Shelves	4
Shelf Material	Glass w/Aluminum Profile
Full Extension Drawers @ 115° Door Opening Angle	Yes
General Use Drawer	2
Door Bins	3
External LED Proximity Sensor	No
Oversized Dispenser Opening	No
Chilled Water, Crushed and Cubed Ice	No
Rapid Water Replenishment System	No
Ice Maker with Diamond Ice System	Yes
Door Open Alarm	Yes
Open Door Assist	Yes
Special Modes	Sabbath, Economy, Vacation

CAPACITY	
Total Unit Gross Capacity (cu. ft.) – AHAM	19.4 cu. ft.
Freezer Gross Capacity (cu. ft.)	19.4 cu. ft.

PERFORMANCE	
Dedicated Evaporator & Compressor System	Yes
SuperFreeze®	Yes
Defrost Process	Frost-Free

TECHNICAL DETAILS	
Watts (W)	504 W
Current (A)	15 A
Volts (V)	120V-3 Prong
Frequency (Hz)	60 Hz
Power Cord Length (in.)	139
Plug Type	120V-3 Prong

DIMENSIONS & WEIGHT	
Appliance Dimensions (H x W x D) (in.)	83 3/4"* x 35 3/4" x 24 3/4"
Required Cutout Size (H x W x D) (in.)	84" x 36" x 25"
Net / Gross Weight (lbs)	522 / 551 lbs

EFFICIENCY	
ENERGY STAR® Qualified	Yes
Annual Energy Consumption	543 kWh

*Height adjustable + / -1/2" (+ / -13 mm)

See page 375 for accessories.

T18IW900SP

18-INCH BUILT-IN WINE PRESERVATION COLUMN

FREEDOM® COLLECTION, PANEL-READY



GENERAL PROPERTIES	
Panel Ready	Yes
Reversible Door Swing	Yes
Lighting	Theater Lighting
Number of Shelves	11
Shelf Material	Wenge Wood / Aluminum Frame
Full Extension Drawers @ 115° Door Opening Angle	Yes
Full Extension Drawers @ 90° Door Opening Angle	Yes
Presenter Shelf	Yes
Portable Aluminum Wine Presenter	Yes
Type of Glass Door	Tempered and UV-protective
Number of Temperature Zones	2
Door Open Alarms	Yes
Open Door Assist	Yes
Special Modes	Sabbath, Economy, Vacation
CAPACITY	
Bottle Capacity (750 ml)	70
TEMPERATURE RANGES	
Zone 1 (Upper Zone)	41°F (5°C) to 64°F (18°C)
Zone 2 (Middle Zone)	41°F (5°C) to 64°F (18°C)
Zone 3 (Lower Zone)	N/A
TECHNICAL DETAILS	
Watts (W)	102W
Current (A)	15 A
Volts (V)	120V-3 Prong
Frequency (Hz)	60 Hz
Power Cord Length (in.)	139
Plug Type	120V-3 Prong
DIMENSIONS & WEIGHT	
Appliance Dimensions (H x W x D) (in.)	83 3/4" x 17 3/4" x 24"
Required Cutout Size (H x W x D) (in.)	84" x 18" x 25"
Net / Gross Weight (lbs)	278 / 297 lbs
EFFICIENCY	
ENERGY STAR® Qualified	No
Annual Energy Consumption	330 kWh

*Height adjustable + / -1/2" (+ / -13 mm)

See page 375 for accessories.

T24IW900SP

24-INCH BUILT-IN WINE PRESERVATION COLUMN

FREEDOM® COLLECTION, PANEL-READY



GENERAL PROPERTIES	
Panel Ready	Yes
Reversible Door Swing	Yes
Lighting	New Bar ALL LED Sidewall and Theater Lighting
Number of Shelves	11
Shelf Material	Wenge Wood / Aluminum Frame
Full Extension Drawers @ 115° Door Opening Angle	Yes
Full Extension Drawers @ 90° Door Opening Angle	Yes
Presenter Shelf	Yes
Portable Aluminum Wine Presenter	Yes
Type of Glass Door	Tempered and UV-protective
Number of Temperature Zones	3
Door Open Alarms	Yes
Open Door Assist	Yes
Special Modes	Sabbath, Economy, Vacation
CAPACITY	
Bottle Capacity (750 ml)	98
TEMPERATURE RANGES	
Zone 1 (Upper Zone)	41°F (5°C) to 64°F (18°C)
Zone 2 (Middle Zone)	41°F (5°C) to 64°F (18°C)
Zone 3 (Lower Zone)	41°F (5°C) to 64°F (18°C)
TECHNICAL DETAILS	
Watts (W)	102 W
Current (A)	15 A
Volts (V)	120V-3 Prong
Frequency (Hz)	60 Hz
Power Cord Length (in.)	139
Plug Type	120V-3 Prong
DIMENSIONS & WEIGHT	
Appliance Dimensions (H x W x D) (in.)	83 3/4" x 23 3/4" x 24"
Required Cutout Size (H x W x D) (in.)	84" x 24" x 25"
Net / Gross Weight (lbs)	328 / 350 lbs
EFFICIENCY	
ENERGY STAR® Qualified	No
Annual Energy Consumption	410 kWh

*Height adjustable + / -1/2" (+ / -13 mm)

See page 375 for accessories.

T30IB900SP

30-INCH BUILT-IN 2-DOOR BOTTOM FREEZER

FREEDOM® COLLECTION, PANEL-READY



GENERAL PROPERTIES	
Panel Ready	Yes
Reversible Door Swing	Yes
SoftClose® Drawers	Yes
Carbon Air Filter	Yes
Lighting	
New Bar ALL LED Sidewall and Theater Lighting	
Full Width Shelves – Refrigerator	2
Adjustable Shelves – Refrigerator	2
Shelf Material	Glass w/Aluminum Profile
Full Extension Drawers @ 115° Door Opening Angle	Yes
Full Extension Drawers @ 90° Door Opening Angle	Yes
Temperature Controlled Drawer	1
Humidity Controlled Drawer	ThermaFresh Plus
General Use Drawer	1
Door Bins – Refrigerator	1
Gallon Door Bins – Refrigerator	1
Delicate Produce Bins	2 Large
Defrost Process – Freezer	Frost-Free
Drawers – Freezer	1
Ice Maker with Diamond Ice System	Yes
Door Open Alarms	Yes
Open Door Assist	Yes
SuperCool	Yes
SuperFreeze®	Yes
Special Modes	Sabbath, Economy, Vacation

CAPACITY	
Total Unit Gross Capacity (cu. ft.) – AHAM	16 cu. ft.
Freezer Gross Capacity (cu. ft.)	4.5 cu. ft.
Refrigerator Gross Capacity (cu. ft.)	11.5 cu. ft.

TECHNICAL DETAILS	
Watts (W)	588 W
Current (A)	15 A
Volts (V)	120V-3 Prong
Frequency (Hz)	60 Hz
Power Cord Length (in.)	139
Plug Type	120V-3 Prong

DIMENSIONS & WEIGHT	
Appliance Dimensions (H x W x D) (in.)	83 3/4" x 29 3/4" x 24"
Required Cutout Size (H x W x D) (in.)	84" x 30" x 25"
Net / Gross Weight (lbs)	408 / 432 lbs

EFFICIENCY	
ENERGY STAR® Most Efficient	Yes
Annual Energy Consumption	511 kWh

See page 375 for accessories.

FEATURES & BENEFITS

- Freedom® Hinge enables true flush design
- The new Auto Door Opening provides the opening of the door with just a slight push or pull
- Delicate Produce Bins for expanded storage
- ThermaFresh System, Humidity and Temperature controlled drawers
- SoftClose® Drawers and Produce Bins for easy and controlled storage
- Sleek clean design for the perfect symmetry when paired with additional columns
- TFT control panel managing all your columns functions

TEMPERATURE RANGES

Refrigerator	35°F (2°C) to 46°F (8°C)
Adjustable Temperature Drawer	32°F (0°C) to 37°F (3°C)
Deli Drawer	N/A
SuperCool	35.5°F (2°C) for approximately 9 hours
Energy Saving (Economy) Mode	Refrigerator: 45°F (7°C) Freezer: 3°F (-16°C)
Freezer	-9°F (-23°C) to 7°F (14°C)
SuperFreeze®	-9°F (-23°C) for approximately 52 hours

*Height adjustable + / -1/2" (+ / -13 mm)

T36IB900SP

36-INCH BUILT-IN 2-DOOR BOTTOM FREEZER

FREEDOM® COLLECTION, PANEL-READY



GENERAL PROPERTIES	
Panel Ready	Yes
Reversible Door Swing	Yes
SoftClose® Drawers	Yes
Carbon Air Filter	Yes
Lighting	
New Bar ALL LED Sidewall and Theater Lighting	
Full Width Shelves – Refrigerator	2
Adjustable Shelves – Refrigerator	2
Shelf Material	Glass w/Aluminum Profile
Full Extension Drawers @ 115° Door Opening Angle	Yes
Full Extension Drawers @ 90° Door Opening Angle	Yes
Temperature Controlled Drawer	1
Humidity Controlled Drawer	ThermaFresh Plus
General Use Drawer	1
Door Bins – Refrigerator	2
Gallon Door Bins – Refrigerator	1
Delicate Produce Bins	2 Large
Defrost Process – Freezer	Frost-Free
Drawers – Freezer	1
Ice Maker with Diamond Ice System	Yes
Door Open Alarms	Yes
Open Door Assist	Yes
SuperCool	Yes
SuperFreeze®	Yes
Special Modes	Sabbath, Economy, Vacation

CAPACITY	
Total Unit Gross Capacity (cu. ft.) – AHAM	19.4 cu. ft.
Freezer Gross Capacity (cu. ft.)	5.5 cu. ft.
Refrigerator Gross Capacity (cu. ft.)	13.9 cu. ft.

TECHNICAL DETAILS	
Watts (W)	588 W
Current (A)	15 A
Volts (V)	120V-3 Prong
Frequency (Hz)	60 Hz
Power Cord Length (in.)	139
Plug Type	120V-3 Prong

DIMENSIONS & WEIGHT	
Appliance Dimensions (H x W x D) (in.)	83 3/4" x 35 3/4" x 24 3/4"
Required Cutout Size (H x W x D) (in.)	84" x 36" x 25"
Net / Gross Weight (lbs)	540 / 573 lbs

EFFICIENCY	
ENERGY STAR® Most Efficient	Yes
Annual Energy Consumption	546 kWh

See page 375 for accessories.

FEATURES & BENEFITS

- Freedom® Hinge enables true flush design
- The new Auto Door Opening provides the opening of the door with just a slight push or pull
- Delicate Produce Bins for expanded storage
- ThermaFresh System, Humidity and Temperature controlled drawers
- SoftClose® Drawers and Produce Bins for easy and controlled storage
- Sleek clean design for the perfect symmetry when paired with additional columns
- TFT control panel managing all your columns functions

TEMPERATURE RANGES

Refrigerator	35°F (2°C) to 46°F (8°C)
Adjustable Temperature Drawer	32°F (0°C) to 37°F (3°C)
Deli Drawer	N/A
SuperCool	35.5°F (2°C) for approximately 9 hours
Energy Saving (Economy) Mode	Refrigerator: 45°F (7°C) Freezer: 3°F (-16°C)
Freezer	-9°F (-23°C) to 7°F (14°C)
SuperFreeze®	-9°F (-23°C) for approximately 52 hours

*Height adjustable + / -1/2" (+ / -13 mm)

T36IT900NP

36-INCH BUILT-IN FRENCH DOOR BOTTOM FREEZER

FREEDOM® COLLECTION, PANEL-READY



GENERAL PROPERTIES	
Panel Ready	Yes
Reversible Door Swing	No
SoftClose® Drawers	Yes
Carbon Air Filter	Yes
Lighting	
New Bar ALL LED Sidewall and Theater Lighting	
Full Width Shelves – Refrigerator	2
Adjustable Shelves – Refrigerator	2
Shelf Material	Glass w/Aluminum Profile
Full Extension Drawers @ 115° Door Opening Angle	Yes
Full Extension Drawers @ 90° Door Opening Angle	Yes
Temperature Controlled Drawer	1
Humidity Controlled Drawer	ThermaFresh Plus
General Use Drawer	1
Door Bins – Refrigerator	2
Gallon Door Bins – Refrigerator	2
Delicate Produce Bins	2 Small
Defrost Process – Freezer	Frost-Free
Drawers – Freezer	1
Ice Maker with Diamond Ice System	Yes
Door Open Alarms	Yes
Open Door Assist	Yes
SuperCool	Yes
SuperFreeze®	Yes
Special Modes	Sabbath, Economy, Vacation

CAPACITY	
Total Unit Gross Capacity (cu. ft.) – AHAM	19.4 cu. ft.
Freezer Gross Capacity (cu. ft.)	5.5 cu. ft.
Refrigerator Gross Capacity (cu. ft.)	13.9 cu. ft.

TECHNICAL DETAILS	
Watts (W)	588 W
Current (A)	15 A
Volts (V)	120V-3 Prong
Frequency (Hz)	60 Hz
Power Cord Length (in.)	139
Plug Type	120V-3 Prong

DIMENSIONS & WEIGHT	
Appliance Dimensions (H x W x D) (in.)	83 3/4" x 35 3/4" x 24 3/4"
Required Cutout Size (H x W x D) (in.)	84" x 36" x 25"
Net / Gross Weight (lbs)	540 / 573 lbs

EFFICIENCY	
ENERGY STAR® Most Efficient	Yes
Annual Energy Consumption	585 kWh

See page 375 for accessories.

FEATURES & BENEFITS

- Freedom® Hinge enables true flush design
- The new Auto Door Opening provides the opening of the door with just a slight push or pull
- Delicate Produce Bins for expanded storage
- ThermaFresh System, Humidity and Temperature controlled drawers
- SoftClose® Drawers and Produce Bins for easy and controlled storage
- Sleek clean design for the perfect symmetry when paired with additional columns
- TFT control panel managing all your columns functions

TEMPERATURE RANGES

Refrigerator	35°F (2°C) to 46°F (8°C)
Adjustable Temperature Drawer	32°F (0°C) to 37°F (3°C)
Deli Drawer	N/A
SuperCool	35.5°F (2°C) for approximately 9 hours
Energy Saving (Economy) Mode	Refrigerator: 45°F (7°C) Freezer: 3°F (-16°C)
Freezer	-9°F (-23°C) to 7°F (14°C)
SuperFreeze®	-9°F (-23°C) for approximately 52 hours

T30BB920SS

30-INCH STAINLESS STEEL BUILT-IN 2-DOOR BOTTOM FREEZER, PRE-ASSEMBLED

FREEDOM® COLLECTION, PROFESSIONAL SERIES HANDLES



Also Available In:
T30BB920SS – Masterpiece® Series Handles

FEATURES & BENEFITS

- Freedom® Hinge enables true flush design
- The new Auto Door Opening provides the opening of the door with just a slight push or pull
- Delicate Produce Bins for expanded storage
- ThermaFresh System, Humidity and Temperature controlled drawers
- SoftClose® Drawers and Produce Bins for easy and controlled storage
- Sleek clean design for the perfect symmetry when paired with additional columns
- TFT control panel managing all your columns functions

TEMPERATURE RANGES

Refrigerator	35°F (2°C) to 46°F (8°C)
Adjustable Temperature Drawer	32°F (0°C) to 37°F (3°C)
Deli Drawer	Just above 32°F (0°C)
SuperCool	35.5°F (2°C) for approximately 9 hours
Energy Saving (Economy) Mode	Refrigerator: 45°F (7°C) Freezer: 3°F (-16°C)
Freezer	-9°F (-23°C) to 7°F (14°C)
SuperFreeze®	-9°F (-23°C) for approximately 52 hours

*Height adjustable + / -1/2" (+ / -13 mm)

GENERAL PROPERTIES	
Reversible Door Swing	Yes
SoftClose® Drawers	Yes
Carbon Air Filter	Yes
Lighting	
New Bar ALL LED Sidewall and Theater Lighting	
Full Width Shelves – Refrigerator	2
Adjustable Shelves – Refrigerator	2
Shelf Material	Glass w/Aluminum Profile
Full Extension Drawers @ 115° Door Opening Angle	Yes
Full Extension Drawers @ 90° Door Opening Angle	Yes
Temperature Controlled Drawer	1
Humidity Controlled Drawer	ThermaFresh Plus
General Use Drawer	1
Door Bins – Refrigerator	1
Gallon Door Bins – Refrigerator	1
Delicate Produce Bins	2 Large
Defrost Process – Freezer	Frost-Free
Drawers – Freezer	1
Ice Maker with Diamond Ice System	Yes
Door Open Alarms	Yes
Open Door Assist	Yes
SuperCool	Yes
SuperFreeze®	Yes
Special Modes	Sabbath, Economy, Vacation

CAPACITY	
Total Unit Gross Capacity (cu. ft.) – AHAM	16.0 cu. ft.
Freezer Gross Capacity (cu. ft.)	4.5 cu. ft.
Refrigerator Gross Capacity (cu. ft.)	11.5 cu. ft.

TECHNICAL DETAILS	
Watts (W)	588 W
Current (A)	15 A
Volts (V)	120V-3 Prong
Frequency (Hz)	60 Hz
Power Cord Length (in.)	139
Plug Type	120V-3 Prong

DIMENSIONS & WEIGHT	
Appliance Dimensions (H x W x D) (in.)	83 3/4" x 29 3/4" x 24"
Required Cutout Size (H x W x D) (in.)	84" x 30" x 25"
Net / Gross Weight (lbs)	408 / 432 lbs

EFFICIENCY	
ENERGY STAR® Most Efficient	Yes
Annual Energy Consumption	511 kWh

See page 375 for accessories.

T30BB910SS
30-INCH STAINLESS STEEL BUILT-IN 2-DOOR
BOTTOM FREEZER, PRE-ASSEMBLED
 FREEDOM® COLLECTION, MASTERPIECE® SERIES HANDLES



GENERAL PROPERTIES	
Reversible Door Swing	Yes
SoftClose® Drawers	Yes
Carbon Air Filter	Yes
Lighting	
New Bar ALL LED Sidewall and Theater Lighting	
Full Width Shelves – Refrigerator	2
Adjustable Shelves – Refrigerator	2
Shelf Material	Glass w/Aluminum Profile
Full Extension Drawers @ 115° Door Opening Angle	Yes
Full Extension Drawers @ 90° Door Opening Angle	Yes
Temperature Controlled Drawer	1
Humidity Controlled Drawer	ThermaFresh Plus
General Use Drawer	1
Door Bins – Refrigerator	1
Gallon Door Bins – Refrigerator	1
Delicate Produce Bins	2 Large
Defrost Process – Freezer	Frost-Free
Drawers – Freezer	1
Ice Maker with Diamond Ice System	Yes
Door Open Alarms	Yes
Open Door Assist	Yes
SuperCool	Yes
SuperFreeze®	Yes
Special Modes	Sabbath, Economy, Vacation

CAPACITY	
Total Unit Gross Capacity (cu. ft.) – AHAM	16.0 cu. ft.
Freezer Gross Capacity (cu. ft.)	4.5 cu. ft.
Refrigerator Gross Capacity (cu. ft.)	11.5 cu. ft.

TECHNICAL DETAILS	
Watts (W)	588 W
Current (A)	15 A
Volts (V)	120V-3 Prong
Frequency (Hz)	60 Hz
Power Cord Length (in.)	139
Plug Type	120V-3 Prong

DIMENSIONS & WEIGHT	
Appliance Dimensions (H x W x D) (in.)	83 3/4" x 29 3/4" x 24"
Required Cutout Size (H x W x D) (in.)	84" x 30" x 25"
Net / Gross Weight (lbs)	408 / 432 lbs

EFFICIENCY	
ENERGY STAR® Most Efficient	Yes
Annual Energy Consumption	511 kWh

Also Available In:
 T30BB920SS – Professional Series Handles

FEATURES & BENEFITS

- Freedom® Hinge enables true flush design
- The new Auto Door Opening provides the opening of the door with just a slight push or pull
- Delicate Produce Bins for expanded storage
- ThermaFresh System, Humidity and Temperature controlled drawers
- SoftClose® Drawers and Produce Bins for easy and controlled storage
- Sleek clean design for the perfect symmetry when paired with additional columns
- TFT control panel managing all your columns functions

TEMPERATURE RANGES

Refrigerator	35°F (2°C) to 46°F (8°C)
Adjustable Temperature Drawer	32°F (0°C) to 37°F (3°C)
Deli Drawer	N/A
SuperCool	35.5°F (2°C) for approximately 9 hours
Energy Saving (Economy) Mode	Refrigerator: 45°F (7°C) Freezer: 3°F (-16°C)
Freezer	-9°F (-23°C) to 7°F (14°C)
SuperFreeze®	-9°F (-23°C) for approximately 52 hours

*Height adjustable + / -1/2" (+ / -13 mm)

See page 375 for accessories.

T36BB920SS
36-INCH STAINLESS STEEL BUILT-IN 2-DOOR
BOTTOM FREEZER, PRE-ASSEMBLED
 FREEDOM® COLLECTION, PROFESSIONAL SERIES HANDLES



GENERAL PROPERTIES	
Reversible Door Swing	Yes
SoftClose® Drawers	Yes
Carbon Air Filter	Yes
Lighting	
New Bar ALL LED Sidewall and Theater Lighting	
Full Width Shelves – Refrigerator	2
Adjustable Shelves – Refrigerator	2
Shelf Material	Glass w/Aluminum Profile
Full Extension Drawers @ 115° Door Opening Angle	Yes
Full Extension Drawers @ 90° Door Opening Angle	Yes
Temperature Controlled Drawer	1
Humidity Controlled Drawer	ThermaFresh Plus
General Use Drawer	1
Door Bins – Refrigerator	2
Gallon Door Bins – Refrigerator	1
Delicate Produce Bins	2 Large, 1 Small
Defrost Process – Freezer	Frost-Free
Drawers – Freezer	1
Ice Maker with Diamond Ice System	Yes
Door Open Alarms	Yes
Open Door Assist	Yes
SuperCool	Yes
SuperFreeze®	Yes
Special Modes	Sabbath, Economy, Vacation

CAPACITY	
Total Unit Gross Capacity (cu. ft.) – AHAM	19.5 cu. ft.
Freezer Gross Capacity (cu. ft.)	5.5 cu. ft.
Refrigerator Gross Capacity (cu. ft.)	14 cu. ft.

TECHNICAL DETAILS	
Watts (W)	588 W
Current (A)	15 A
Volts (V)	120V-3 Prong
Frequency (Hz)	60 Hz
Power Cord Length (in.)	139
Plug Type	120V-3 Prong

DIMENSIONS & WEIGHT	
Appliance Dimensions (H x W x D) (in.)	83 3/4" x 35 3/4" x 24 3/4"
Required Cutout Size (H x W x D) (in.)	84" x 36" x 25"
Net / Gross Weight (lbs)	541 / 573 lbs

EFFICIENCY	
ENERGY STAR® Most Efficient	Yes
Annual Energy Consumption	546 kWh

Also Available In:
 T36BB910SS – Masterpiece® Series Handles

FEATURES & BENEFITS

- Freedom® Hinge enables true flush design
- The new Auto Door Opening provides the opening of the door with just a slight push or pull
- Delicate Produce Bins for expanded storage
- ThermaFresh System, Humidity and Temperature controlled drawers
- SoftClose® Drawers and Produce Bins for easy and controlled storage
- Sleek clean design for the perfect symmetry when paired with additional columns
- TFT control panel managing all your columns functions

TEMPERATURE RANGES

Refrigerator	35°F (2°C) to 46°F (8°C)
Adjustable Temperature Drawer	32°F (0°C) to 37°F (3°C)
Deli Drawer	N/A
SuperCool	35.5°F (2°C) for approximately 9 hours
Energy Saving (Economy) Mode	Refrigerator: 45°F (7°C) Freezer: 3°F (-16°C)
Freezer	-9°F (-23°C) to 7°F (14°C)
SuperFreeze®	-9°F (-23°C) for approximately 52 hours

*Height adjustable + / -1/2" (+ / -13 mm)

See page 375 for accessories.

T36BB910SS
36-INCH STAINLESS STEEL BUILT-IN 2-DOOR
BOTTOM FREEZER, PRE-ASSEMBLED
 FREEDOM® COLLECTION, MASTERPIECE® SERIES HANDLES



GENERAL PROPERTIES	
Reversible Door Swing	Yes
SoftClose® Drawers	Yes
Carbon Air Filter	Yes
Lighting	
New Bar ALL LED Sidewall and Theater Lighting	
Full Width Shelves – Refrigerator	2
Adjustable Shelves – Refrigerator	2
Shelf Material	Glass w/Aluminum Profile
Full Extension Drawers @ 115° Door Opening Angle	Yes
Full Extension Drawers @ 90° Door Opening Angle	Yes
Temperature Controlled Drawer	1
Humidity Controlled Drawer	ThermaFresh Plus
General Use Drawer	1
Door Bins – Refrigerator	2
Gallon Door Bins – Refrigerator	1
Delicate Produce Bins	2 Large, 1 Small
Defrost Process – Freezer	Frost-Free
Drawers – Freezer	1
Ice Maker with Diamond Ice System	Yes
Door Open Alarms	Yes
Open Door Assist	Yes
SuperCool	Yes
SuperFreeze®	Yes
Special Modes	Sabbath, Economy, Vacation

CAPACITY	
Total Unit Gross Capacity (cu. ft.) – AHAM	19.5 cu. ft.
Freezer Gross Capacity (cu. ft.)	5.5 cu. ft.
Refrigerator Gross Capacity (cu. ft.)	14 cu. ft.

TECHNICAL DETAILS	
Watts (W)	588 W
Current (A)	15 A
Volts (V)	120V-3 Prong
Frequency (Hz)	60 Hz
Power Cord Length (in.)	139
Plug Type	120V-3 Prong

DIMENSIONS & WEIGHT	
Appliance Dimensions (H x W x D) (in.)	83 3/4" x 35 3/4" x 24 3/4"
Required Cutout Size (H x W x D) (in.)	84" x 36" x 25"
Net / Gross Weight (lbs)	541 / 573 lbs

EFFICIENCY	
ENERGY STAR® Most Efficient	Yes
Annual Energy Consumption	546 kWh

Also Available In:
 T36BB920SS – Professional Series Handles

FEATURES & BENEFITS

- Freedom® Hinge enables true flush design
- The new Auto Door Opening provides the opening of the door with just a slight push or pull
- Delicate Produce Bins for expanded storage
- ThermaFresh System, Humidity and Temperature controlled drawers
- SoftClose® Drawers and Produce Bins for easy and controlled storage
- Sleek clean design for the perfect symmetry when paired with additional columns
- TFT control panel managing all your columns functions

TEMPERATURE RANGES

Refrigerator	35°F (2°C) to 46°F (8°C)
Adjustable Temperature Drawer	32°F (0°C) to 37°F (3°C)
Deli Drawer	Just above 32°F (0°C)
SuperCool	35.5°F (2°C) for approximately 9 hours
Energy Saving (Economy) Mode	Refrigerator: 45°F (7°C) Freezer: 3°F (-16°C)
Freezer	-9°F (-23°C) to 7°F (14°C)
SuperFreeze®	-9°F (-23°C) for approximately 52 hours

*Height adjustable + / -1/2" (+ / -13 mm)

See page 375 for accessories.

T36BT920NS
36-INCH STAINLESS STEEL BUILT-IN FRENCH
DOOR BOTTOM FREEZER, PRE-ASSEMBLED
 FREEDOM® COLLECTION, PROFESSIONAL SERIES HANDLES



GENERAL PROPERTIES	
Reversible Door Swing	No
SoftClose® Drawers	Yes
Carbon Air Filter	Yes
Lighting	
New Bar ALL LED Sidewall and Theater Lighting	
Full Width Shelves – Refrigerator	2
Adjustable Shelves – Refrigerator	2
Shelf Material	Glass w/Aluminum Profile
Full Extension Drawers @ 115° Door Opening Angle	Yes
Full Extension Drawers @ 90° Door Opening Angle	Yes
Temperature Controlled Drawer	1
Humidity Controlled Drawer	ThermaFresh Plus
General Use Drawer	1
Door Bins – Refrigerator	2
Gallon Door Bins – Refrigerator	2
Delicate Produce Bins	2 Small
Defrost Process – Freezer	Frost-Free
Drawers – Freezer	1
Ice Maker with Diamond Ice System	Yes
Door Open Alarms	Yes
Open Door Assist	Yes
SuperCool	Yes
SuperFreeze®	Yes
Special Modes	Sabbath, Economy, Vacation

CAPACITY	
Total Unit Gross Capacity (cu. ft.) – AHAM	19.4 cu. ft.
Freezer Gross Capacity (cu. ft.)	5.5 cu. ft.
Refrigerator Gross Capacity (cu. ft.)	13.9 cu. ft.

TECHNICAL DETAILS	
Watts (W)	588 W
Current (A)	15 A
Volts (V)	120V-3 Prong
Frequency (Hz)	60 Hz
Power Cord Length (in.)	139
Plug Type	120V-3 Prong

DIMENSIONS & WEIGHT	
Appliance Dimensions (H x W x D) (in.)	83 3/4" x 35 3/4" x 24 3/4"
Required Cutout Size (H x W x D) (in.)	84" x 36" x 25"
Net / Gross Weight (lbs)	541 / 573 lbs

EFFICIENCY	
ENERGY STAR® Most Efficient	Yes
Annual Energy Consumption	585 kWh

Also Available In:
 T36BT910NS – Masterpiece® Series Handles

FEATURES & BENEFITS

- Freedom® Hinge enables true flush design
- The new Auto Door Opening provides the opening of the door with just a slight push or pull
- Delicate Produce Bins for expanded storage
- ThermaFresh System, Humidity and Temperature controlled drawers
- SoftClose® Drawers and Produce Bins for easy and controlled storage
- Sleek clean design for the perfect symmetry when paired with additional columns
- TFT control panel managing all your columns functions

TEMPERATURE RANGES

Refrigerator	35°F (2°C) to 46°F (8°C)
Adjustable Temperature Drawer	32°F (0°C) to 37°F (3°C)
Deli Drawer	N/A
SuperCool	35.5°F (2°C) for approximately 9 hours
Energy Saving (Economy) Mode	Refrigerator: 45°F (7°C) Freezer: 3°F (-16°C)
Freezer	-9°F (-23°C) to 7°F (14°C)
SuperFreeze®	-9°F (-23°C) for approximately 52 hours

*Height adjustable + / -1/2" (+ / -13 mm)

See page 375 for accessories.

T36BT910NS
36-INCH STAINLESS STEEL BUILT-IN FRENCH
DOOR BOTTOM FREEZER, PRE-ASSEMBLED
 FREEDOM® COLLECTION, MASTERPIECE® SERIES HANDLES



Also Available In:
 T36BT920NS – Professional Series Handles

FEATURES & BENEFITS

- Freedom® Hinge enables true flush design
- The new Auto Door Opening provides the opening of the door with just a slight push or pull
- Delicate Produce Bins for expanded storage
- ThermaFresh System, Humidity and Temperature controlled drawers
- SoftClose® Drawers and Produce Bins for easy and controlled storage
- Sleek clean design for the perfect symmetry when paired with additional columns
- TFT control panel managing all your columns functions

TEMPERATURE RANGES

Refrigerator	35°F (2°C) to 46°F (8°C)
Adjustable Temperature Drawer	32°F (0°C) to 37°F (3°C)
Deli Drawer	Just above 32°F (0°C)
SuperCool	35.5°F (2°C) for approximately 9 hours
Energy Saving (Economy) Mode	Refrigerator: 45°F (7°C) Freezer: 3°F (-16°C)
Freezer	-9°F (-23°C) to 7°F (14°C)
SuperFreeze®	-9°F (-23°C) for approximately 52 hours

*Height adjustable + / -1/2" (+ / -13 mm)

GENERAL PROPERTIES

Reversible Door Swing	No
SoftClose® Drawers	Yes
Carbon Air Filter	Yes
Lighting	
New Bar ALL LED Sidewall and Theater Lighting	
Full Width Shelves – Refrigerator	2
Adjustable Shelves – Refrigerator	2
Shelf Material	Glass w/Aluminum Profile
Full Extension Drawers @ 115° Door Opening Angle	Yes
Full Extension Drawers @ 90° Door Opening Angle	Yes
Temperature Controlled Drawer	1
Humidity Controlled Drawer	ThermaFresh Plus
General Use Drawer	1
Door Bins – Refrigerator	2
Gallon Door Bins – Refrigerator	2
Delicate Produce Bins	2 Small
Defrost Process – Freezer	Frost-Free
Drawers – Freezer	1
Ice Maker with Diamond Ice System	Yes
Door Open Alarms	Yes
Open Door Assist	Yes
SuperCool	Yes
SuperFreeze®	Yes
Special Modes	Sabbath, Economy, Vacation

CAPACITY

Total Unit Gross Capacity (cu. ft.) – AHAM	19.4 cu. ft.
Freezer Gross Capacity (cu. ft.)	5.5 cu. ft.
Refrigerator Gross Capacity (cu. ft.)	13.9 cu. ft.

TECHNICAL DETAILS

Watts (W)	588 W
Current (A)	15 A
Volts (V)	120V-3 Prong
Frequency (Hz)	60 Hz
Power Cord Length (in.)	139
Plug Type	120V-3 Prong

DIMENSIONS & WEIGHT

Appliance Dimensions (H x W x D) (in.)	83 3/4" x 35 3/4" x 24 3/4"
Required Cutout Size (H x W x D) (in.)	84" x 36" x 25"
Net / Gross Weight (lbs)	541 / 573 lbs

EFFICIENCY

ENERGY STAR® Most Efficient	Yes
Annual Energy Consumption	585 kWh

See page 375 for accessories.



KITCHEN DESIGN BY: LINDA MCCLAIN & LINDSAY HULSEY, SIGNATURE KITCHENS & BATHS OF CHARLESTON, INC.

FRESH FOOD COLUMNS

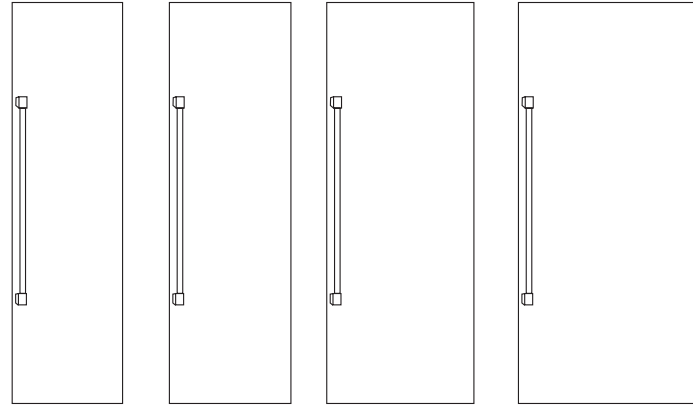

T23IR900SP	T24IR900SP	T30IR900SP	T36IR900SP
23.5-Inch	24-Inch	30-Inch	36-Inch
Reversible Door Swing	Reversible Door Swing	Reversible Door Swing	Reversible Door Swing
Build Your Custom Column	Build Your Custom Column	Build Your Custom Column	Build Your Custom Column

WINE PRESERVATION COLUMNS

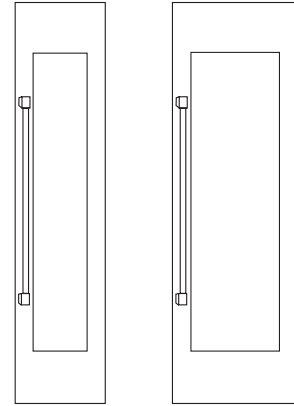

T18IW900SP	T24IW900SP
18-Inch	24-Inch
Reversible Door Swing	Reversible Door Swing
Build Your Custom Column	Build Your Custom Column

BOTTOM FREEZERS

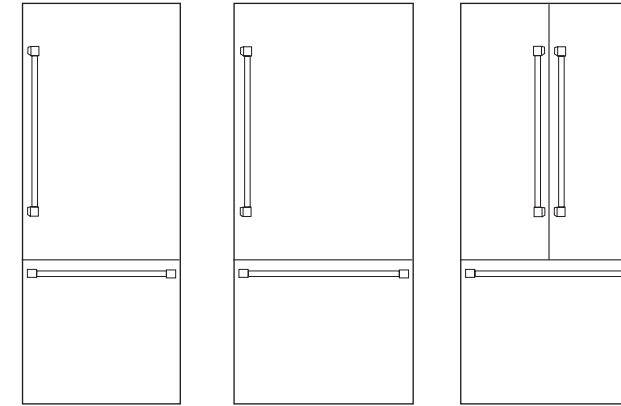

T30IB900SP	T36IB900SP	T36IT900NP
30-Inch 2-Door	36-Inch 2-Door	36-Inch French Door
Reversible Door Swing	Reversible Door Swing	Reversible Door Swing
Build Your Custom Column	Build Your Custom Column	Build Your Custom Column

★ **PLANNING TIP**

A Frame Kit enables installation of all Freedom Columns in 24-inch deep cutouts. See page 375 for details.

FREEZER COLUMNS WITH EXTERNAL DISPENSER

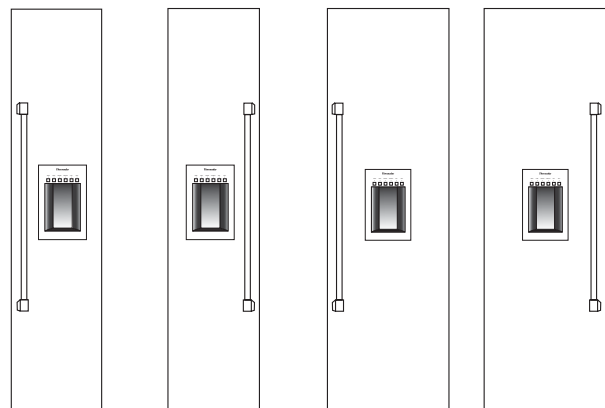

T18ID900RP	T18ID900LP	T24ID900RP	T24ID900LP
18-Inch	18-Inch	24-Inch	24-Inch
External Ice & Water Dispenser	External Ice & Water Dispenser	External Ice & Water Dispenser	External Ice & Water Dispenser
Right-Hand Door Swing	Left-Hand Door Swing	Right-Hand Door Swing	Left-Hand Door Swing
Build Your Custom Column	Build Your Custom Column	Build Your Custom Column	Build Your Custom Column

FREEZER COLUMNS WITH INTERNAL ICE MAKER

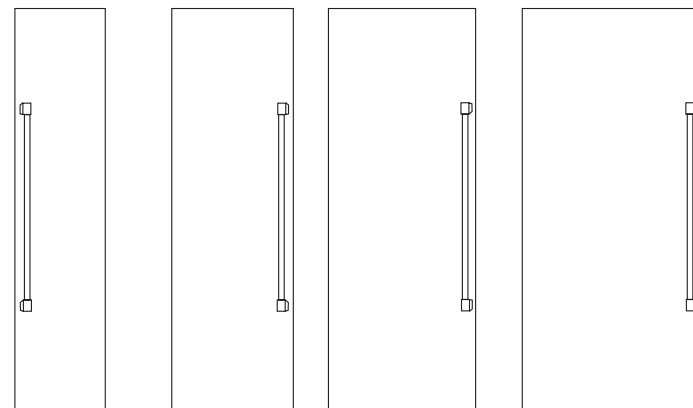





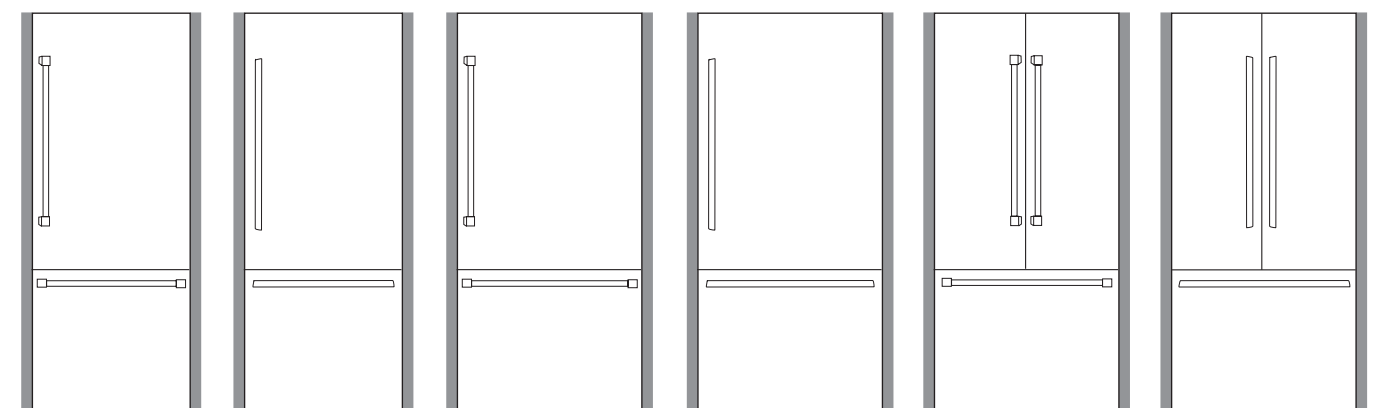









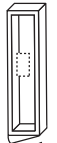

T18IF900SP	T24IF900SP	T30IF900SP	T36IF900SP
18-Inch	24-Inch	30-Inch	36-Inch
Internal Ice Maker	Internal Ice Maker	Internal Ice Maker	Internal Ice Maker
Reversible Door Swing	Reversible Door Swing	Reversible Door Swing	Reversible Door Swing
Build Your Custom Column	Build Your Custom Column	Build Your Custom Column	Build Your Custom Column

PRE-ASSEMBLED BOTTOM FREEZERS*

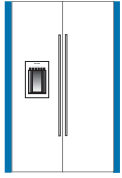
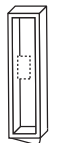

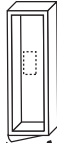

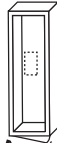





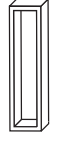

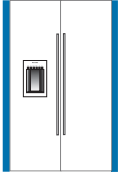

T30BB920SS	T30BB910SS	T36BB920SS	T36BB910SS	T36BT920NS	T36BT910NS
30-Inch 2-Door	30-Inch 2-Door	36-Inch 2-Door	36-Inch 2-Door	36-Inch French Door	36-Inch French Door
Reversible Door Swing	Reversible Door Swing	Reversible Door Swing	Reversible Door Swing	—	—
Flat Stainless Steel Panels	Flat Stainless Steel Panels	Flat Stainless Steel Panels	Flat Stainless Steel Panels	Flat Stainless Steel Panels	Flat Stainless Steel Panels
Professional Handles	Masterpiece® Handles	Professional Handles	Masterpiece® Handles	Professional Handles	Masterpiece® Handles

*Pre-assembled bottom freezers can be installed flush in 25-inch deep cutouts or with included frame in 24-inch deep cutouts.

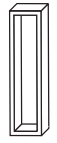
CHOOSE UNIT	CHOOSE PANEL (All units are panel ready for custom panel installation)	CHOOSE HANDLE AND OPTIONAL FRAME
FRESH FOOD COLUMN – FULLY FLUSH COLLECTION		
23.5-Inch  T23IR900SP Reversible Door Swing Custom Column	 TFL23IR900 Flat Stainless Steel Door Panel	<p>NOTE: Choose one handle for each column, 2 handles for each 2-door bottom freezer and 3 handles for each French Door bottom freezer.</p> <p>Professional Series PR36HNDL20 – 36-Inch Professional PR30HNDL20 – 30-Inch Professional</p> <p>Masterpiece® Series MS36HNDL20 – 36-Inch Masterpiece MS30HNDL20 – 30-Inch Masterpiece</p> <p>Professional Series – Classic PR36HNDL10 – 36-Inch Professional Classic PR30HNDL10 – 30-Inch Professional Classic</p>
24-Inch  T24IR900SP Reversible Door Swing Custom Column	 TFL24IR800 Flat Stainless Steel Door Panel	
30-Inch  T30IR900SP Reversible Door Swing Custom Column	 TFL30IR800 Flat Stainless Steel Door Panel	
36-Inch  T36IR900SP Reversible Door Swing Custom Column	 TFL36IR900 Flat Stainless Steel Door Panel	
FREEZER COLUMN WITH EXTERNAL DISPENSER – FULLY FLUSH COLLECTION		
18-Inch  T18ID900RP Right-Hand Door Swing External Ice & Water Dispenser Custom Column	 TFL18ID800 Flat Stainless Steel Door Panel	<p>Masterpiece® Series – Classic MS36HNDL10 – 36-Inch Masterpiece Classic MS30HNDL10 – 30-Inch Masterpiece Classic</p>  <p>Freedom® Frame Kit FRAMEKIT10 Included with all pre-assembled bottom freezers, this adjustable frame is also available as an optional accessory for use with any custom column for installation in 24-inch (610 mm) deep cutouts. The kit includes two identical and reversible metal side trims whose placement between the interior cutout wall and the appliance helps overcome the challenge of unfinished cabinet returns.</p>
18-Inch  T18ID900LP Left-Hand Door Swing External Ice & Water Dispenser Custom Column	 TFL18ID800 Flat Stainless Steel Door Panel	
24-Inch  T24ID900RP Right-Hand Door Swing External Ice & Water Dispenser Custom Column	 TFL24ID800 Flat Stainless Steel Door Panel	
24-Inch  T24ID900LP Left-Hand Door Swing External Ice & Water Dispenser Custom Column	 TFL24ID800 Flat Stainless Steel Door Panel	





IMPORTANT: When two appliances are installed side-by-side a sealing kit must be used. For combinations that involve a freezer column, this kit is included. For all other (non-traditional, i.e. two wine columns, two bottom freezers, etc.) side-by-side combinations or instances where any appliances are installed less than 6-inches (152 mm) apart from one another but not connected side-by-side, Heater Kit HEATRKIT10 (27W @ 120V) or HEATRKIT20 (13W @ 120V) must be purchased. This kit is recommended for use with any installation in areas that are subject to humidity, or located next to an outside wall. See page 375 for details.

CHOOSE UNIT	CHOOSE PANEL (All units are panel ready for custom panel installation)	CHOOSE HANDLE AND OPTIONAL FRAME
FREEZER COLUMN WITH INTERNAL ICE MAKER – FULLY FLUSH COLLECTION		
18-Inch  T18IF900SP Right-Hand Door Swing External Ice & Water Dispenser Custom Column	 TFL18IR800 Flat Stainless Steel Door Panel	<p>Professional Series PR36HNDL20 – 36-Inch Professional PR30HNDL20 – 30-Inch Professional</p> <p>Masterpiece® Series MS36HNDL20 – 36-Inch Masterpiece MS30HNDL20 – 30-Inch Masterpiece</p> <p>Professional Series – Classic PR36HNDL10 – 36-Inch Professional Classic PR30HNDL10 – 30-Inch Professional Classic</p> <p>Masterpiece® Series – Classic MS36HNDL10 – 36-Inch Masterpiece Classic MS30HNDL10 – 30-Inch Masterpiece Classic</p>  <p>Freedom® Frame Kit FRAMEKIT10 Included with all pre-assembled bottom freezers, this adjustable frame is also available as an optional accessory for use with any custom column for installation in 24-inch (610 mm) deep cutouts. The kit includes two identical and reversible metal side trims whose placement between the interior cutout wall and the appliance helps overcome the challenge of unfinished cabinet returns.</p>
24-Inch  T24IF900SP Right-Hand Door Swing External Ice & Water Dispenser Custom Column	 TFL24IR800 Flat Stainless Steel Door Panel	
30-Inch  T30IF900SP Right-Hand Door Swing External Ice & Water Dispenser Custom Column	 TFL30IR800 Flat Stainless Steel Door Panel	
36-Inch  T36IF900SP Right-Hand Door Swing External Ice & Water Dispenser Custom Column	 TFL36IR900 Flat Stainless Steel Door Panel	
WINE PRESERVATION – FULLY FLUSH COLLECTION		
18-Inch  T18IW900SP Reversible Door Swing Custom Column	 TFL18IW800 Flat Stainless Steel Door Panel	<p>Freedom® Frame Kit FRAMEKIT10 Included with all pre-assembled bottom freezers, this adjustable frame is also available as an optional accessory for use with any custom column for installation in 24-inch (610 mm) deep cutouts. The kit includes two identical and reversible metal side trims whose placement between the interior cutout wall and the appliance helps overcome the challenge of unfinished cabinet returns.</p>
24-Inch  T24IW900SP Reversible Door Swing Custom Column	 TFL24IW800 Flat Stainless Steel Door Panel	

IMPORTANT: When two appliances are installed side-by-side a sealing kit must be used. For combinations that involve a freezer column, this kit is included. For all other (non-traditional, i.e. two wine columns, two bottom freezers, etc.) side-by-side combinations or instances where any appliances are installed less than 6-inches (152 mm) apart from one another but not connected side-by-side, Heater Kit HEATRKIT10 (27W @ 120V) or HEATRKIT20 (13W @ 120V) must be purchased. This kit is recommended for use with any installation in areas that are subject to humidity, or located next to an outside wall. See page 375 for details.

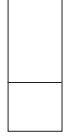
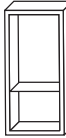
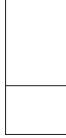
FREEDOM® COLLECTION

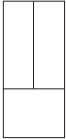
BUILDING YOUR CUSTOM COLUMN





CHOOSE UNIT	CHOOSE PANEL (All units are panel ready for custom panel installation)	CHOOSE HANDLE AND OPTIONAL FRAME NOTE: Choose one handle for each column, 2 handles for each 2-door bottom freezer and 3 handles for each French Door bottom freezer.
BOTTOM FREEZER – FULLY FLUSH COLLECTION		
30-Inch  <p>T30IB900SP 2-Door Reversible Door Swing Custom Column</p>	 <p>TFL30IB800 Flat Stainless Steel Door Panel</p>	<p>Professional Series PR36HNDL20 – 36-Inch Professional PR30HNDL20 – 30-Inch Professional</p> <p>Masterpiece® Series MS36HNDL20 – 36-Inch Masterpiece MS30HNDL20 – 30-Inch Masterpiece</p>
36-Inch  <p>T36IB900SP 2-Door Reversible Door Swing Custom Column</p>	 <p>TFL36IB800 Flat Stainless Steel Door Panel</p>	<p>Professional Series – Classic PR36HNDL10 – 36-Inch Professional Classic PR30HNDL10 – 30-Inch Professional Classic</p> <p>Masterpiece® Series – Classic MS36HNDL10 – 36-Inch Masterpiece Classic MS30HNDL10 – 30-Inch Masterpiece Classic</p>
36-Inch  <p>T36IT900NP French Door Custom Column</p>	 <p>TFL36IT800 Flat Stainless Steel Door Panel</p>	 <p>Included with all pre-assembled bottom freezers, this adjustable frame is also available as an optional accessory for use with any custom column for installation in 24-inch (610 mm) deep cutouts. The kit includes two identical and reversible metal side trims whose placement between the interior cutout wall and the appliance helps overcome the challenge of unfinished cabinet returns.</p> <p>Freedom® Frame Kit FRAMEKIT10</p>

IMPORTANT: When two appliances are installed side-by-side a sealing kit must be used. For combinations that involve a freezer column, this kit is included. For all other (non-traditional, i.e. two wine columns, two bottom freezers, etc.) side-by-side combinations or instances where any appliances are installed less than 6-inches (152 mm) apart from one another but not connected side-by-side, Heater Kit HEATRKIT10 (27W @ 120V) or HEATRKIT20 (13W @ 120V) must be purchased. This kit is recommended for use with any installation in areas that are subject to humidity, or located next to an outside wall. See page 375 for details.

CHOOSE UNIT

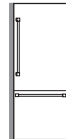
PRE-ASSEMBLED BOTTOM FREEZER – FULLY FLUSH COLLECTION

A frame is attached to all pre-assembled models. It is removable if a flush installation in a 25" deep cabinet is desired.

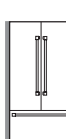
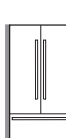
30-Inch  <p>T30BB920SS 2-Door Professional Handles</p>	<p>Reversible Door Swing Flat Stainless Steel Panels Removable Frame</p>
30-Inch  <p>T30BB910SS 2-Door Masterpiece® Handles</p>	<p>Reversible Door Swing Flat Stainless Steel Panels Removable Frame</p>
36-Inch  <p>T36BB920SS 2-Door Professional Handles</p>	<p>Reversible Door Swing Flat Stainless Steel Panels Removable Frame</p>
36-Inch  <p>T36BB910SS 2-Door Masterpiece® Handles</p>	<p>Reversible Door Swing Flat Stainless Steel Panels Removable Frame</p>
36-Inch  <p>T36BT920NS French Door Professional Handles</p>	<p>Flat Stainless Steel Panels Removable Frame</p>
36-Inch  <p>T36BT910NS French Door Masterpiece® Handles</p>	<p>Flat Stainless Steel Panels Removable Frame</p>

IMPORTANT: When two appliances are installed side-by-side a sealing kit must be used. For combinations that involve a freezer column, this kit is included. For all other (non-traditional, i.e. two wine columns, two bottom freezers, etc.) side-by-side combinations or instances where any appliances are installed less than 6-inches (152 mm) apart from one another but not connected side-by-side, Heater Kit HEATRKIT10 (27W @ 120V) or HEATRKIT20 (13W @ 120V) must be purchased. This kit is recommended for use with any installation in areas that are subject to humidity, or located next to an outside wall. See page 375 for details.

CUSTOMIZE THE INTERIOR

OPTIONAL STORAGE ACCESSORIES

See pages 328-329 for inspiration on how to combine interior storage accessories to suit your culinary lifestyle.

Fresh Food Columns, Bottom Freezers and Pre-assembled Bottom Freezers



SPRODBIN10
Small Delicate
Produce Bin



LPRODBIN10
Large Delicate
Produce Bin



24PRODRAIL
24-Inch
Produce Bin Railing



30PRODRAIL
30-Inch
Produce Bin Railing



36PRODRAIL
36-Inch
Produce Bin Railing



3DPRODRAIL
French Door
Produce Bin Railing



24HFGALBIN
24-Inch
Half Gallon Bin



30HFGALBIN
30-Inch
Half Gallon Bin



36HFGALBIN
36-Inch
Half Gallon Bin



3DHFGALBIN
French Door
Half Gallon Bin



3DHFGALBIN
French Door Half Gallon Bin



ICEBUCKETL
Large Ice Bucket

Freezer Columns, Bottom Freezers and Pre-assembled Bottom Freezers



This custom product requires attention to the finest details. Did you remember to...?

- Choose a desired configuration – side-by-side or stand-alone columns (See pages 378–381 for details)
- Plan the cutout height(s) – 84" (See pages 378–381 for details)
- Plan the cutout width(s) – depends on configuration and column width (See pages 378–381 for details)
- Plan the cutout depth – 25" for North American style cabinets, 24" with installation frame accessory, 24" for European style cabinets (See pages 378–381 for details)
- Ensure the cutout interior (top and sides) is flush to the appliance at a depth of min. 4", preferably 6" from face frame (See pages 378–381 for details)
- Ensure the cutout interior returns (top and sides) are finished to match exterior at a depth of min. 4", preferably 6" from face frame (See pages 378–381 for details)
- Ensure proper clearance for appliance doors including handle(s) – check for interference with other appliances, open or closed cabinets and doors, nearby walls (See page 373 for details)
- Properly site the electrical outlet and (if applicable) water box (See pages 376-377 for details)
- Ensure the reverse of any custom panel is finished to match the exterior
- Choose the handle style – Professional Series, Professional Series Classic, Masterpiece® Series, Masterpiece® Series Classic or custom
- Choose the correct handle length. Typically, all columns would use a 36" handle. The 30" handle must be used on the 30" bottom freezer drawer.
- Choose the toekick style – stainless (included with appliance) or design custom toekick(s) (See page 382 for details)
- Procure the proper installation accessories – stainless steel frame kit (FRAMEKIT10) for framed installations in 24-inch deep cutouts, heater kit (HEATRKIT10 or HEATRKIT20) for installations where two appliances are installed side-by-side or instances where any appliances are installed less than 6" apart from another but not connected. The heater kit is also recommended for use with any installation in areas that are subject to humidity, or located next to an outside wall. (See page 375 for details)
- If applicable, procure the proper water filter accessories – additional replacement filters (REPLFLTR10), filter by-pass (SCRNFLTR10) for in-home water filtration system (See page 375 for details)

The Thermador® Freedom® Collection uses independent columns that create unlimited flexibility in both function and design. Some suggested pairings are listed below. A special kit is included with all freezer columns to simplify traditional side-by-side refrigerator / freezer combinations. When combining two appliances where one is not a freezer column or if any two units are installed less than 6" (152 mm) apart from one another but not connected side-by-side, always use the Heater Kit (HEATRKIT10 or HEATRKIT20) to guard against damaging condensation build-up.

42-INCH

	18-Inch Freezer Column T18IF900SP		18-Inch Freezer Column T18ID900LP		18-Inch Freezer Column T18IF900SP		18-Inch Freezer Column T18ID900LP
	24-Inch Fresh Food Column T24IR900SP		24-Inch Fresh Food Column T24IR900SP		24-Inch Fresh Food Column T24IR900SP		24-Inch Fresh Food Column T24IR900SP
				Shown with FRAMEKIT10			
				Shown with FRAMEKIT10			

48-INCH

	18-Inch Freezer Column T18IF900SP		18-Inch Freezer Column T18ID900LP		24-Inch Fresh Food Column T24IF900SP		24-Inch Fresh Food Column T24IF900SP
	30-Inch Fresh Food Column T30IR900SP		30-Inch Fresh Food Column T30IR900SP		24-Inch Fresh Food Column T24IR900SP		24-Inch Fresh Food Column T24IR900SP
	24-Inch Freezer Column T24IF900SP		24-Inch Freezer Column T24IF900SP		30-Inch* 2-Door Bottom Freezer T30IB900SP		18-Inch* Wine Preservation Column T18IW900SP
	24-Inch Fresh Food Column T24IR900SP		24-Inch Fresh Food Column T24IR900SP				
Shown with FRAMEKIT10				Shown with FRAMEKIT10			

54-INCH

	24-Inch Freezer Column T24IF900SP		24-Inch Freezer Column T24ID900LP		36-Inch* 2-Door Bottom Freezer T36IB900SP		30-Inch* 2-Door Bottom Freezer T30IB900SP
	30-Inch Fresh Food Column T30IR900SP		30-Inch Fresh Food Column T30IR900SP		18-Inch* Wine Preservation Column T18IW900SP		24-Inch* Wine Preservation Column T24IW900SP

60-INCH

	30-Inch Freezer Column T30IF900SP		36-Inch* 2-Door Bottom Freezer T36IB900SP		30-Inch* 2-Door Bottom Freezer T30IB900SP
	30-Inch Fresh Food Column T30IR900SP		24-Inch* Wine Preservation Column T24IW900SP		30-Inch* 2-Door Bottom Freezer T30IB900SP

*Requires Heater Kit HEATRKIT10

INSTALLATION CONSIDERATIONS

LOCATION

The appliance should be installed in a dry, ventilated room. It may not be installed outdoors. The ambient temperature of the room must be between 55°F (13°C) and 100°F (43°C).

The appliance should not be exposed to constant direct sunlight or excessive heat. If installation next to a heat source, such as an oven, radiator, etc. is unavoidable, use a suitable insulating plate or observe the following minimum distances from the heat source:

- 1 1/4" (30 mm) from an electric cooking appliance,
- 11 13/16" (300 mm) from an oil or solid-fuel cooking appliance.

INSTALLATION AND CUTOUT DIMENSIONS

Please see pages 378–381 for complete cutout planning information.

It is important to observe the specified dimensions of the installation cutout for a trouble-free installation of the appliance and for the subsequent appearance of the door panel.

- In particular ensure that the cutout is square. Squareness can be checked by suitable means, e.g. spirit level, diagonal measurements, etc.

- The side walls of the cutout must be flush. The minimum thickness of the side and top walls is 5/8" (16 mm). The minimum thickness of toekick panel is 1/4" (6 mm).

FURNITURE / FIXTURES

During installation, the appliance is fastened to adjacent and overhead furniture / fixtures and it is therefore essential that all such furniture / fixtures are well secured to the substructure or adjacent wall.



FLOORING / SUBSTRUCTURE

On account of the heavy weight of a fully loaded appliance, a load-bearing substructure is required. To ensure correct installation and function, the support must be flat, level and made of hard, rigid material. If in doubt, contact an architect or a building expert. Refer to the following table for load-bearing capacity:

APPLIANCE	LOAD BEARING CAPACITY
23.5-Inch Fresh Food Column	945 lbs. / 429 kg
24-Inch Fresh Food Column	949 lbs. / 431 kg
30-Inch Fresh Food Column	1,097 lbs. / 498 kg
36-Inch Fresh Food Column	1,363 lbs. / 618 kg
18-Inch Freezer Column	774 lbs. / 351 kg*
24-Inch Freezer Column	958 lbs. / 435 kg*
30-Inch Freezer Column	1,116 lbs. / 507 kg
36-Inch Freezer Column	1,351 lbs. / 614 kg
18-Inch Wine Preservation Column	840 lbs. / 381 kg
24-Inch Wine Preservation Column	1,067 lbs. / 484 kg
30-Inch Bottom Freezer, 2-Door	1,135 lbs. / 515 kg**
36-Inch Bottom Freezer, 2-Door	1,399 lbs. / 635 kg**
36-Inch Bottom Freezer, French Door	1,382 lbs. / 627 kg**

*Without water dispenser **Pre-assembled units

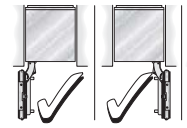
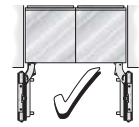
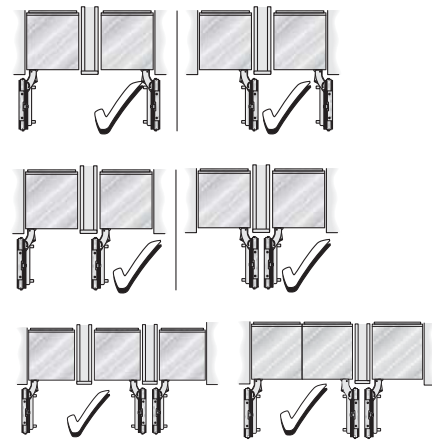
The Freedom® Collection offers a variety of installation possibilities*. In some instances, special accessories are required.

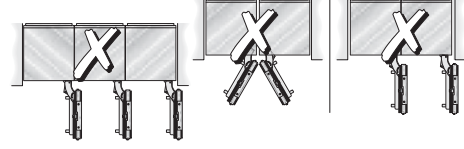
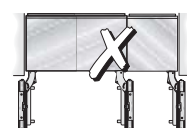
RECOMMENDED INSTALLATIONS	CONSIDERATIONS
<p>STAND-ALONE</p> 	Any Freedom appliance can be installed as a stand-alone unit. Ensure a cutout flush to the appliance at a depth of minimum 4" (102 mm), preferably 6" (152 mm) on the top and sides.
<p>SIDE-BY-SIDE</p> 	When two appliances are installed side-by-side a sealing kit must be used. For combinations that involve a freezer column, this kit is provided. For all other (non-traditional) side-by-side combinations or instances where any appliances are installed less than 6" (152 mm) apart from one another but not connected side-by-side, purchase the Heater Kit (HEATRKIT10 or HEATRKIT20).
<p>SPLIT COLUMNS WITH PARTITION</p> 	When dimensioning the partition, note the thickness of the door panel (including handles) as well as the swivel range to prevent damage if the doors are opened at the same time. (See pages 382-383 for details on door swivel range dimensions) Three appliances can be installed together only if a partition—minimum 5/8" (16 mm)—is placed between two of the appliances. Ensure that door panel thickness (including handles) as well as the swivel range are accounted for.
<p>AT THE END OF A CABINERY RUN</p> 	All Freedom appliances must be completely enclosed on the top and sides. If one side of the appliance is visible, a decorative side panel must be used. The side panel must be connected firmly to the wall, the floor and any overhead furniture / fixtures before the appliance is placed in the cutout.
NOT RECOMMENDED	CONCERNS
	It is absolutely essential to ensure that the appliance is installed in such a way that the doors do not interfere with an adjacent wall or other kitchen elements. (See pages 382-383 for details on door swivel range dimensions)
	A partition—minimum 5/8" (16 mm)—is required to ensure the doors do not interfere with one another when opened. Use a partition to separate appliances and observe the door swivel range. (See pages 382-383 for details on door swivel range dimensions)
	A Thermador French Door Bottom Freezer cannot be connected side-by-side with any other appliance. Use a partition to separate appliances and observe the door swivel range. (See pages 382-383 for details on door swivel range dimensions)

*The Thermador warranty shall apply only to recommended installations.

FREEDOM® COLLECTION

DOOR PANEL DIMENSIONS

Each Freedom® Collection refrigeration appliance is designed to be equipped with a decorative door panel. A panel can be custom-made or purchased as a stainless steel accessory. The table below illustrates the dimensions of the stainless steel panel accessories and can be used as a guide in creating custom panels. At 79 7/8" (2029 mm) tall, they are designed for a toekick height of 4" (102 mm), and a total cutout height of 84" (2134 mm) yielding 1/8" (3 mm) reveals. At 3/4" (19 mm) deep, they are designed to attach to the 24" (610 mm) deep appliance for an overall depth of 24 3/4" (629 mm). See page 379 for cutout planning.

When using custom panels, always ensure that the panel reverse is finished to match the exterior, as parts of the panel reverse will be visible when the refrigerator door is opened.

IMPORTANT: While these sketches can serve as a general guide in planning panel dimensions, the correct panel dimensions are dictated by design choices including style and dimensions of surrounding kitchen cabinetry, case and toekick height, etc. Please ensure careful planning based on the specific kitchen design.

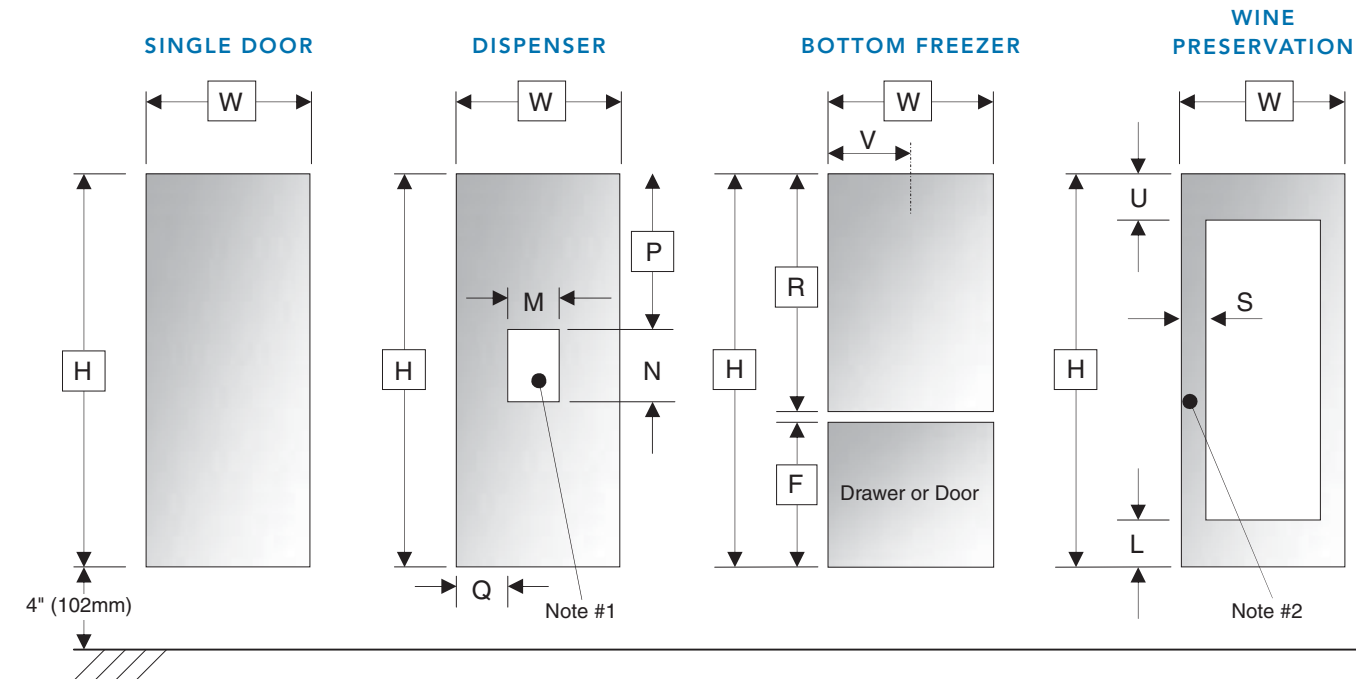

MODEL	DESCRIPTION	H	W	V	R	F	M	N	P	Q	U	L	S	MAX. PANEL WEIGHT
T18IF900SP	18-Inch Freezer Column	79 7/8" (2029 mm)	17 3/4" (451 mm)	—	—	—	—	—	—	—	—	—	—	37 lbs. (17kg)
T23IR900SP	23.5-Inch Fresh Food Column	79 7/8" (2029 mm)	23 17/64" (591 mm)	—	—	—	—	—	—	—	—	—	—	50 lbs. (23kg)
T24IR900SP T24IF900SP	24-Inch Freezer / Fresh Food Columns	79 7/8" (2029 mm)	23 3/4" (603 mm)	—	—	—	—	—	—	—	—	—	—	50 lbs. (23kg)
T30IR900SP T30IF900SP	30-Inch Freezer / Fresh Food Columns	79 7/8" (2029 mm)	29 3/4" (756 mm)	—	—	—	—	—	—	—	—	—	—	64 lbs. (29kg)
T36IR900SP T36IF900SP	36-Inch Freezer / Fresh Food Columns	79 7/8" (2029 mm)	35 3/4" (908 mm)	—	—	—	—	—	—	—	—	—	—	66 lbs. (30kg)
T18ID900RP T18ID900LP	18-Inch Ice & Water Dispenser Columns	79 7/8" (2029 mm)	17 3/4" (451 mm)	—	—	—	9 1/16" (230.5 mm)	14 1/2" (368.3 mm)	32 11/16" (830.5 mm)	4 11/32" (110 mm)	—	—	—	37 lbs. (17kg)
T24ID900RP T24ID900LP	24-Inch Ice & Water Dispenser Columns	79 7/8" (2029 mm)	23 3/4" (603 mm)	—	—	—	9 1/16" (230.5 mm)	14 1/2" (368.3 mm)	32 11/16" (830.5 mm)	7 11/32" (186 mm)	—	—	—	50 lbs. (23kg)
T30IB900SP	30-Inch Two-Door Bottom Freezer	79 7/8" (2029 mm)	29 3/4" (756 mm)	—	51 11/32" (1304 mm)	28 13/32" (722 mm)	—	—	—	—	—	—	—	55 lbs. (25kg)
T36IB900SP	36-Inch Two-Door Bottom Freezer	79 7/8" (2029 mm)	35 3/4" (908 mm)	—	51 11/32" (1304 mm)	28 13/32" (722 mm)	—	—	—	—	—	—	—	55 lbs. (25kg)
T36IT900NP	36-Inch French Door Bottom Freezer	79 7/8" (2029 mm)	35 3/4" (908 mm)	17 3/4" (451 mm)	51 11/32" (1304 mm)	28 13/32" (722 mm)	—	—	—	—	—	—	—	55 lbs. (25kg)
T18IW900SP	18-Inch Wine Preservation Column	79 7/8" (2029 mm)	17 3/4" (451 mm)	—	—	—	—	—	—	—	10 1/8" (257 mm)	10 1/8" (257 mm)	3 3/4" (95 mm)	37 lbs. (17kg)
T24IW900SP	24-Inch Wine Preservation Column	79 7/8" (2029 mm)	23 3/4" (603 mm)	—	—	—	—	—	—	—	10 1/8" (257 mm)	10 1/8" (257 mm)	3 3/4" (95 mm)	50 lbs. (23kg)

NOTE #1: The cutout for the dispenser unit must be horizontally and vertically centered in the panel.

NOTE #2: For custom wine preservation column door panels, the width of the two lateral flanges of the frame may vary between 2 1/2" (64 mm) and 3 3/4" (95 mm).

FREEDOM® COLLECTION

OPTIONAL ACCESSORIES

FLAT STAINLESS STEEL DOOR PANELS



FRESH FOOD

- TFL23IR900 – 23.5-Inch
- TFL24IR800 – 24-Inch
- TFL30IR800 – 30-Inch
- TFL36IR900 – 36-Inch

FREEZER

- TFL18ID800 – 18-Inch with Dispenser
- TFL18IR800 – 18-Inch without Dispenser
- TFL24ID800 – 24-Inch with Dispenser
- TFL24IR800 – 24-Inch without Dispenser
- TFL30IR800 – 30-Inch without Dispenser
- TFL36IR900 – 36-Inch without Dispenser

BOTTOM FREEZER

- TFL30IB800 – 30-Inch 2-Door
- TFL36IB800 – 36-Inch 2-Door
- TFL36IT800 – 36-Inch French Door

WINE PRESERVATION

- TFL18IW800 – 18-Inch
- TFL24IW800 – 24-Inch

REFRIGERATION STORAGE



DELICATE PRODUCE BIN

- SPRODBIN10 – Small
- LPRODBIN10 – Large



PRODUCE BIN RAILING

- 24PRODRAIL – 24-Inch
- 30PRODRAIL – 30-Inch
- 36PRODRAIL – 36-Inch
- 3DPRODRAIL – French Door



HALF GALLON BIN

- 24HFGALBIN – 24-Inch
- 30HFGALBIN – 30-Inch
- 36HFGALBIN – 36-Inch
- 3DHFGALBIN – French Door



LARGE ICE BUCKET

ICEBUCKETL

REFRIGERATION FILTERS

REPLFLTR10

Water Filter
Replacement water filter for use in all freezer and bottom freezer models.

SCRNFLTR10

Filter By-Pass
Filter by-pass for use with existing in-home water filtration systems. For all freezer and bottom freezer models.

REFRIGERATION HANDLES

NOTE:

Choose one handle for each Column, choose two handles for each 2-Door Bottom Freezer and choose three handles for each French Door Bottom Freezer.

PROFESSIONAL SERIES

- PR36HNDL20 – 36-Inch Professional
- PR30HNDL20 – 30-Inch Professional

MASTERPIECE® SERIES

- MS36HNDL20 – 36-Inch Masterpiece
- MS30HNDL20 – 30-Inch Masterpiece

PROFESSIONAL SERIES – CLASSIC

- PR36HNDL10 – 36-Inch Professional Classic
- PR30HNDL10 – 30-Inch Professional Classic

MASTERPIECE® SERIES – CLASSIC

- MS36HNDL10 – 36-Inch Masterpiece Classic
- MS30HNDL10 – 30-Inch Masterpiece Classic

INSTALLATION ACCESSORIES

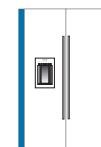

FRAMEKIT10

Freedom® Frame Kit

Included with all pre-assembled bottom freezers, this adjustable frame is also available as an optional accessory for use with any custom column for installation in 24-inch (610 mm) deep cutouts. The kit includes two identical and reversible metal side trims whose placement between the interior cutout wall and the appliance helps overcome the challenge of unfinished cabinet returns.

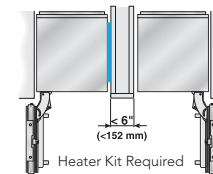

HEATRKIT10 – 27W @ 120V

HEATRKIT20 – 13W @ 120V

Freedom® Heater Kit

When two appliances are installed side-by-side a sealing kit must be used. For combinations that involve a freezer column, this kit is included. For all other (non-traditional, i.e. two wine columns, two bottom freezers, etc.) side-by-side combinations or instances where any appliances are installed less than 6-inches (152 mm) apart from one another but not connected side-by-side, purchase this kit. This kit is recommended for use with any installation in areas that are subject to humidity, or located next to an outside wall.

FREEDOM® COLLECTION

PLANNING INFORMATION

ELECTRICAL SPECIFICATIONS

The appliance comes with a 3-wire power supply cord. UL listed in the USA.

The appliance requires a 3-wire receptacle that is fitted with a 15 Amp fuse or higher. Refer to the following table for max load details.

APPLIANCE	MAX LOAD
	120V AC, 60Hz
23.5-Inch Fresh Food Column	15 A
24-Inch Fresh Food Column	15 A
30-Inch Fresh Food Column	15 A
36-Inch Fresh Food Column	15 A
18-Inch Freezer Column*	15 A
24-Inch Freezer Column*	15 A
30-Inch Freezer Column*	15 A
36-Inch Freezer Column*	15 A
18-Inch Wine Preservation Column	15 A
24-Inch Wine Preservation Column	15 A
30-Inch 2-Door Bottom Freezer*	15 A
36-Inch 2-Door Bottom Freezer*	15 A
36-Inch French Door Bottom Freezer*	15 A

*Including ice maker

The receptacle must be installed by a licensed electrician only. For the installation position of the receptacle refer to diagram in "Electrical Location".

GROUNDING INSTRUCTION

This appliance must be grounded. In the event of a malfunction or breakdown, grounding will reduce the risk of electric shock by providing a path of least resistance for the electric current.

ADDITIONAL GROUNDING PROCEDURE

Some local regulations may require a separate ground. In such cases, the required accessory ground wire, clamp and screw must be purchased separately. Never ground the appliance to plastic plumbing lines, gas lines or water pipes.

A 4-conductor cord shall be used when the appliance is installed in an area where local codes do not permit grounding through the neutral. Power supply cord must be replaced by a licensed electrician only.

WARNING

Improper connection of the equipment grounding conductor may result in electric shock. Have the appliance checked by a qualified electrician or service technician if you are in doubt as to whether the appliance has been properly grounded.

ELECTRICAL LOCATION

Connect the appliance to an outlet that is near the appliance. The outlet must be freely accessible following installation of the appliance.

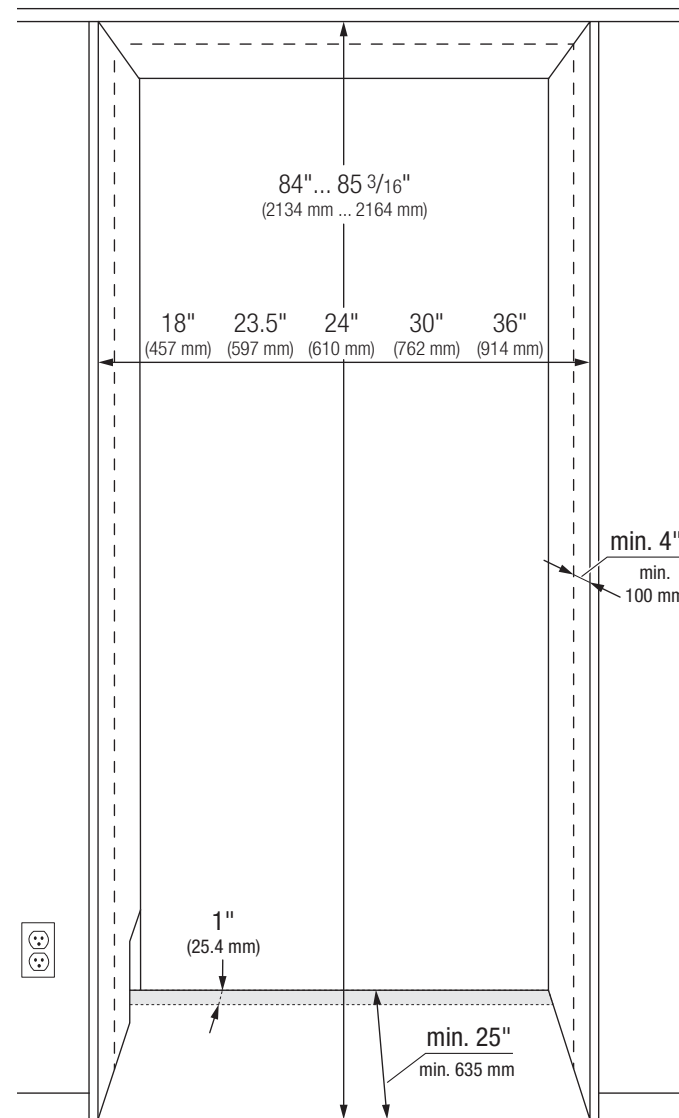

WATER LOCATION

A cold water connection is required for appliances that feature an ice maker or an ice and water dispenser.

The water pressure must be between 40 and 120 p.s.i. (2.75-8.25 bar). The installation must comply with local plumbing regulations. A separate shut-off valve must be installed for the appliance water connection.

The shut-off valve for the water connection may not be behind the appliance. It is recommended to place the shut-off valve outside the cutout next to the appliance or in another easily accessible location. When installing the water connection, observe the permitted installation areas for the water supply line. The supply line can be located to the right (a), to the left (b), or underneath (c).

FREEDOM® COLLECTION

PLANNING INFORMATION

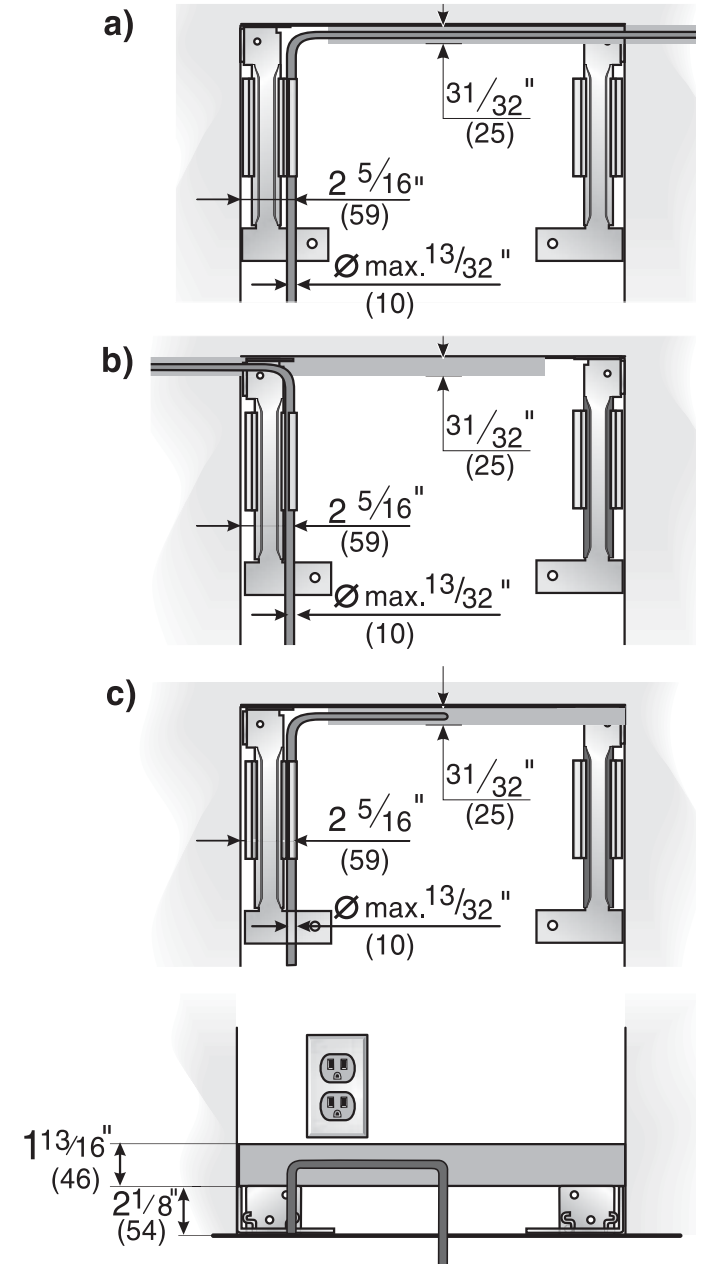

FREEDOM® COLLECTION INSTALLATION DIMENSIONS

CABINERY TERMS & BASIC REQUIREMENTS

To clarify the terms that are used in this design guide, please refer to the following definitions:

CASE

This is the main body of a kitchen cabinet.

(CABINET) FACE FRAME

This is a decorative frame at the front of a kitchen cabinet representing the space between cabinetry doors or drawers and is typical for North America. European style cabinets (frameless cabinetry) typically do not have a face frame.

DOOR PANEL

Able to be fully flush integrated when installed in 25" (635 mm) deep cabinets, Freedom® Collection refrigerators are intentionally designed to be equipped with custom door panels that perfectly match surrounding kitchen cabinetry. Typical panel thickness is 3/4" (19 mm). However, thicker panels can be accommodated to emulate the look of the visible face frame (as in overlay) or to match existing kitchen cabinetry doors. When using custom panels, always ensure that the panel reverse is finished to match the exterior, as parts of the panel reverse will be visible when the refrigerator door is opened.

KITCHEN CABINERY ILLUSTRATION

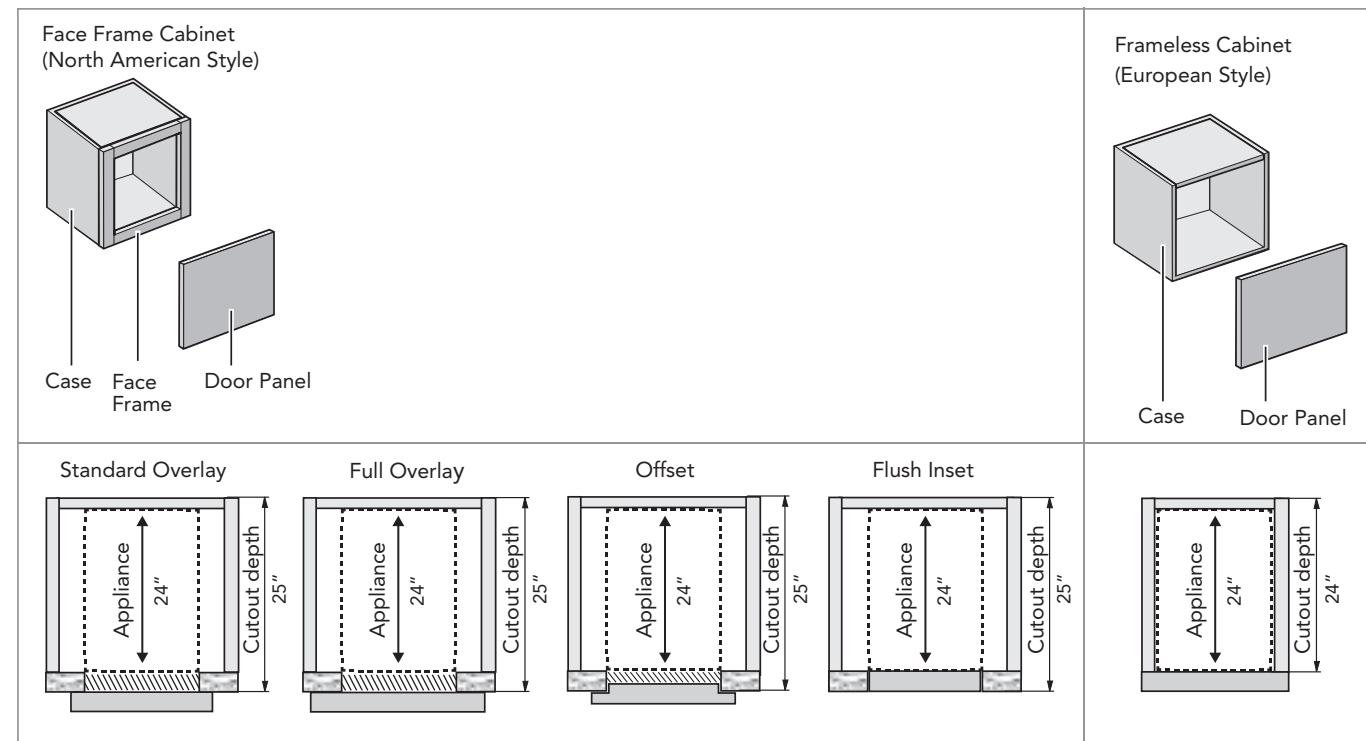

CUTOUT (NICHE)

The cutout is the cavity in which a Freedom® Collection appliance is installed. The width of the cutout (18-inch, 23.5-inch, 24-inch, 30-inch or 36-inch) is dependent on the appliance(s). The total depth of the cutout is equal to the depth of the case plus face frame. It does not necessarily include the thickness of the door panel. For proper planning of cutout depth, please refer to pages 378–381.

Typically, the cutout for a Freedom® Collection appliance will be 25" (635 mm) deep. When planning the cutout, it is essential that the top and side interior walls be flush to the appliance at a minimum depth of 4" (102 mm) from the outer edge of the face frame and composed of thick (5/8" (16 mm) minimum) material for secure installation. Also, because the case interior will be partially visible when the refrigerator door is opened, always ensure that the top and side returns are finished to match the exterior furniture at the same minimum depth of 4" (102 mm).

CABINERY STYLE & CUTOUT DEPTH

Freedom® Collection refrigeration appliances are designed to accommodate nearly any type of kitchen cabinetry door installation. Generally, when using standard 3/4" (19 mm) panels, 25" (635 mm) deep cutouts are recommended but the required cutout depth depends on the desired cabinetry and custom panel execution, whether typical North American styles that employ a face frame—requiring a depth of 25" (635 mm)—or European style—requiring a depth of 24" (610 mm).

The below cabinetry styles detail requirements for the cutout and custom panel.

A) STANDARD (PARTIAL) OVERLAY – 25" (635 MM) CUTOUT DEPTH

With standard overlay kitchen cabinetry the face frame is an important design element. In order to emulate this aesthetic for the refrigerator, one must account for the door panel thickness (typically 3/4" (19 mm)) as well as the face frame thickness (here, also 3/4" (19 mm)). The resulting thickness of the custom door panel is therefore 3/4" (19 mm) + 3/4" (19 mm) = 1 1/2" (38 mm). The cumulative thickness of the custom door panel requires added depth in the cutout so 25" (635 mm) is recommended (see sketch).

B) FULL OVERLAY – 25" (635 MM) CUTOUT DEPTH

The requirements for standard overlays are also valid for full overlay designs so 25" (635 mm) cutout depth is recommended. However, especially if kitchen cabinet doors are thinner than 3/4" (19 mm) or reveals are 1/8" (3 mm) or smaller, a 24" (610 mm) cutout depth may also be acceptable. In this execution both the cabinet door and the small reveal of the fully overlaid face frame must be emulated within the typical appliance door panel thickness of 3/4" (19 mm). This can be done either a) by simply ignoring the visible area of the face frame (very small reveals show virtually no face frame) or b) by creating a "nose" on the custom door panel to emulate a small visible face frame (see sketch).

C & D) OFFSET & FLUSH INSET – 25" (635 MM) CUTOUT DEPTH

Here, kitchen cabinetry door panels do not rest atop the cabinet face frame (overlay), but are instead inserted partially (offset) or fully flush (inset) into the face frame. Such offset or flush inset door panels require additional depth in the cutout. Using the example of a 3/4" (19 mm) thick panel, the complete cutout depth would be 24" (610 mm) + 3/4" (19 mm) = 24 3/4" (629 mm) and in this example 25" (635 mm) is recommended.

E) FRAMED – 24" (610 MM) CUTOUT DEPTH

For Freedom® Collection refrigeration appliances, a metal frame (FRAMEKIT10) may be affixed to the side of the cabinet which conveniently hides unfinished case returns and provides a classic built-in look. This is particularly relevant for existing cabinetry that has not been custom-built to accommodate these appliances. A 24" (610 mm) cutout will result in a slightly protruding door panel for a typical built-in look.

FREEDOM® COLLECTION INSTALLATION DIMENSIONS

F) EUROPEAN STYLE KITCHEN CABINERY – 24" (610 MM) CUTOUT DEPTH

If the kitchen design is based on European style cabinetry, there is no need to emulate the look of a face frame, as such a frame is not an element of the kitchen cabinetry design. Therefore a 24" (610 mm) deep cutout with accompanying custom panel will always be sufficient.

A) STANDARD OVERLAY DESIGN

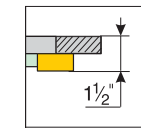

Custom Door Panel (Emulating a Face Frame)

B) FULL OVERLAY DESIGN

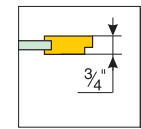

Custom Door Panel with Nose (Emulating a Face Frame)

IMPORTANT

It is strongly recommended the top interior of the cutout be of solid material (5/8" (16 mm) thickness). Ensure that the top well is completely flush for a depth of at least 4" (102 mm).

Ensure that the side walls of the cutout are also completely flush to a depth of at least 4" (102 mm).

If, for some reason, a separate cutout cabinet is created, ensure that the furniture return is at least 4" (102 mm) deep for proper installation.

PLANNING EXAMPLE #1: FRAMELESS (EUROPEAN) CABINETRY

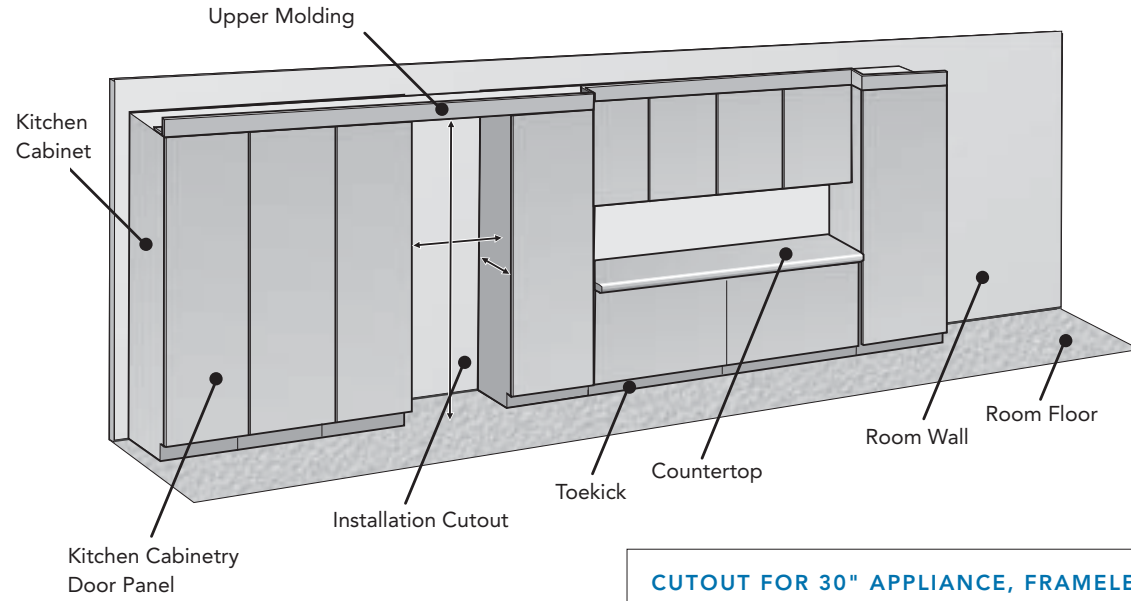

CUTOUT FOR 30" APPLIANCE, FRAMELESS CABINETRY:
In this example, the installation cutout is formed by simply leaving a gap between two kitchen cabinets.

The custom door panel 3/4" (19 mm) will be identical in appearance and thickness to the surrounding kitchen cabinetry panels.

- cutout width is exactly 30" (762 mm)
- cutout (case) depth is 24" (610 mm)—does not include door panel
- top and side walls of cutout interior are completely flush, of solid material and at least 4" (102 mm) deep

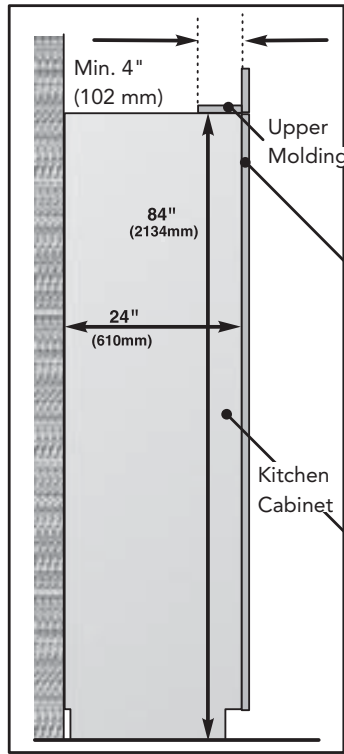

INSTALLATION CUTOUT (VERTICAL SECTION)

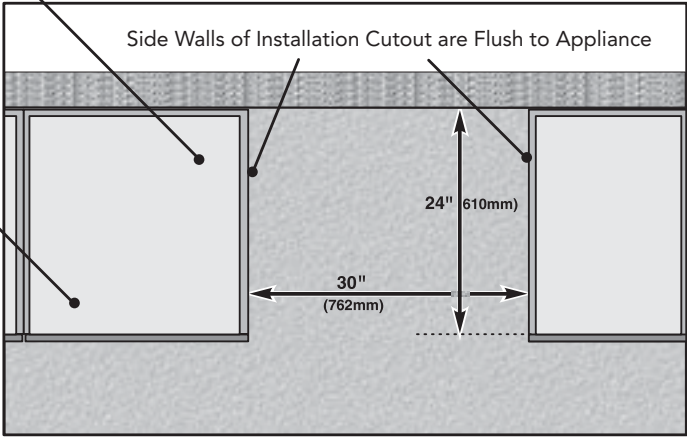

30-INCH INSTALLATION CUTOUT (HORIZONTAL SECTION)

PLANNING EXAMPLE #2: STANDARD OVERLAY CABINETRY

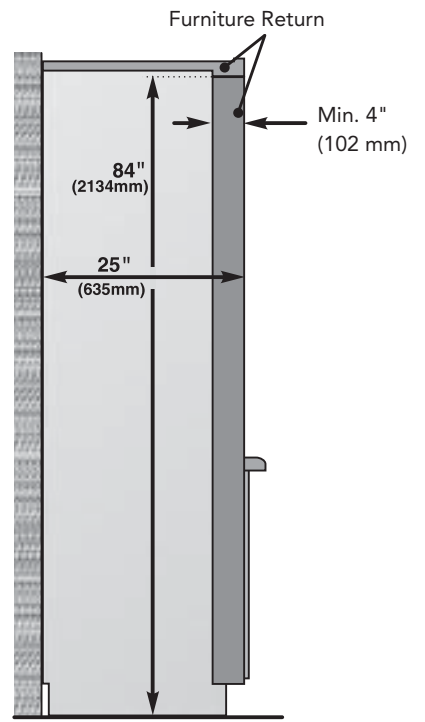
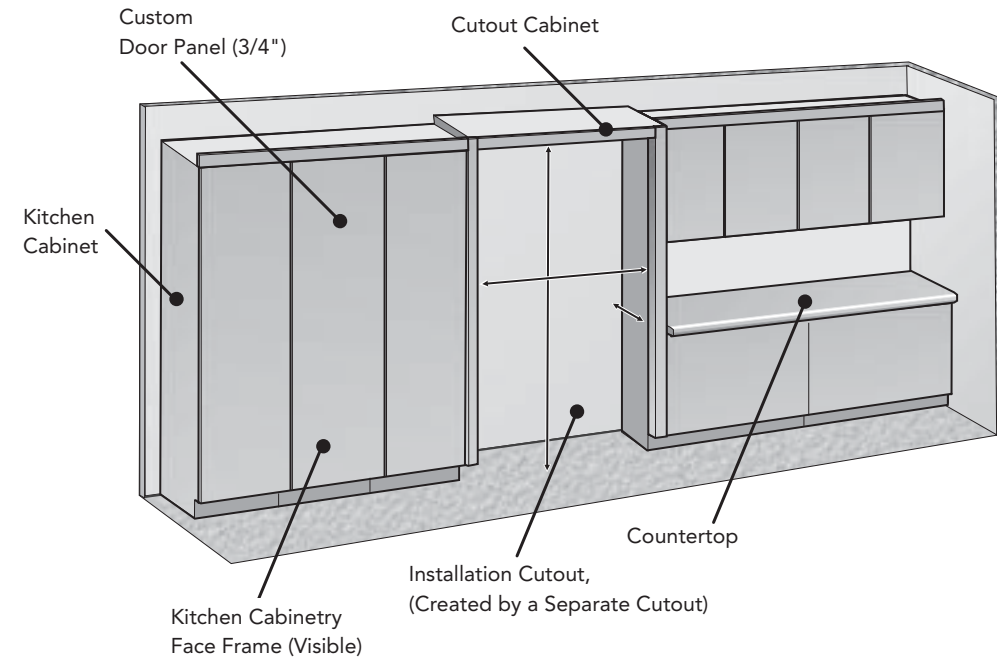

CUTOUT FOR 42" SIDE-BY-SIDE APPLIANCE COMBINATION, STANDARD OVERLAY CABINETRY:
In this example, the installation cutout is formed by creating a separate cutout around the appliances. It yields a look that deviates from the general kitchen design. The custom door panel has a cumulative thickness of 1 1/2" (38 mm), 3/4" (19 mm) emulating the face frame and 3/4" (19 mm) for the actual door panel). Thus, a 25" (635 mm) deep installation cutout is required.

- cutout width is exactly 42" (for an 18" + 24" = 42" side-by-side combination)
- cutout (case) depth is 25" (635 mm) due to 1 1/2" (38 mm) custom door panel
- any furniture return must be at least 4" (102 mm) deep, on interior top and sides, of solid material and should be finished to match the exterior at the same depth (4" or 102 mm)

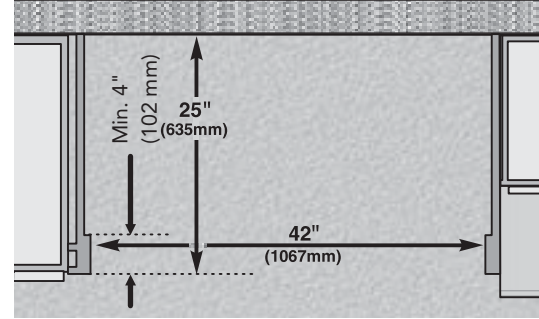

FREEDOM® COLLECTION

INSTALLATION DIMENSIONS

TOEKICK & VENTING GRILLE

Each Freedom® Collection refrigeration appliance comes with a 4" (102 mm) tall stainless steel toekick. A custom-made toekick that matches the surrounding cabinetry may be applied instead. While standard toekick height is 4" (102 mm), depending on the usage of the leveling legs, the toekick height could vary. Regardless of toekick height, it is imperative that the venting grille remain unblocked to ensure proper functionality of the appliance. Decorative toekicks should be removable to allow for servicing.

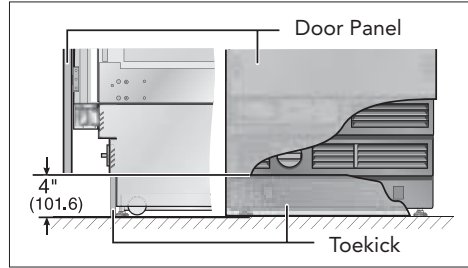

Typical 4" (102 mm) toekick height. Velcro adhesive strips are used to fasten the toekick to the appliance. Venting grille and (if applicable) the water filter cavity are located above the toekick area.

UPPER MOLDING

The planning of decorative upper molding above the cutout requires taking into account the actual or desired height of the door panel. The overall height of the door panel will depend on:

- the height of the appliance, typically 84" (2134 mm)—leveling legs allow height adjustment ranging from -1/2" (-13 mm) to +1 3/8" (+35 mm)
- the installed height of the door panel (distance from the bottom edge of the door panel to the floor, typically 4" (102 mm), and, if desired, any extension of the custom panel above the appliance cutout)
- the appliance type (single door or bottom freezer)

IMPORTANT

Please recall that a panel should be installed at a minimum height of 4" (102 mm) from the floor to allow proper ventilation of the appliance.

Always ensure that the top of the cutout or upper decorative molding is at least 4" (102 mm) deep, so that the refrigerator can be properly secured to the cutout wall. This is particularly important if a protruding cutout is specially created and configured with a face frame. Furniture returns for any face frame must be a minimum of 4" (102 mm) deep.

DOOR SWIVEL RANGE

It is absolutely essential to ensure that the appliance is installed in such a way that the doors (including handles) and adjacent cabinets, countertops, pilasters, walls or other kitchen elements do not interfere with one another when opened. The illustrations below depict the swivel range of the Freedom® Collection refrigerator doors including mounted door panels of both 3/4" (19 mm) and 1 1/2" (38 mm) thickness.

In the event of door interference the following solutions may be employed:

- Limit the refrigerator door opening angle to 90° with a door stop pin inserted into the hinge.
- Reduce the door panel thickness (if larger than 3/4" (19 mm)).
- Install a spacer between the appliance and the kitchen element that creates the interference.
- Rearrange the opposing kitchen element that creates the problem.
- Create a protruding cutout for the appliance.

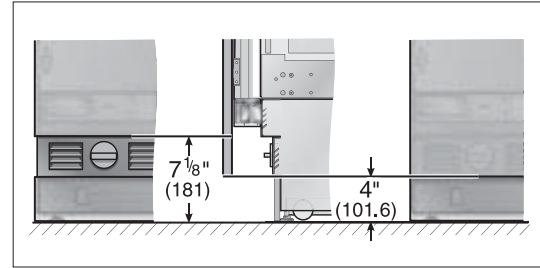

If required by the surrounding cabinetry design, the distance between the bottom edge of the door panel and the floor can be increased from approx. 4" (102 mm) up to 7 1/8" (181 mm), but should not be decreased. Note, however, that the venting grille and (if applicable) water filter cavity will be visible, even if the door is closed.

VERTICAL SECTION, SIDE VIEW:

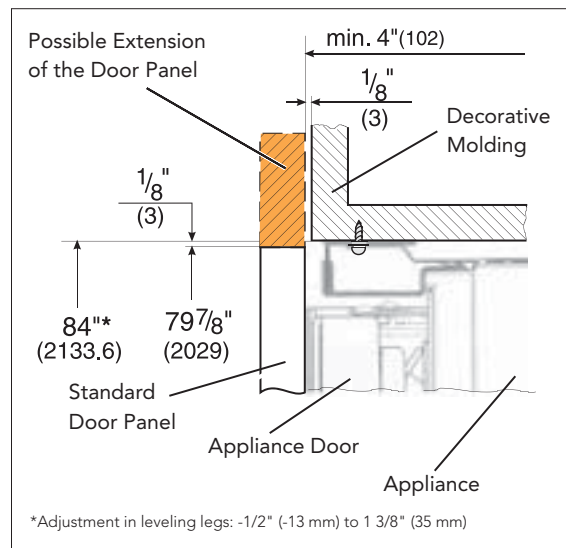

FREEDOM® COLLECTION

INSTALLATION DIMENSIONS

DOOR SWIVEL RANGE – 3/4" (19 MM) FLUSH APPLIANCE DOOR PANEL

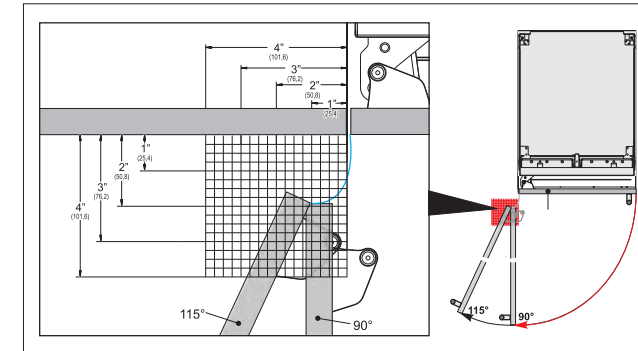

DOOR SWIVEL RANGE – 1 1/2" (38 MM) FLUSH APPLIANCE DOOR PANEL

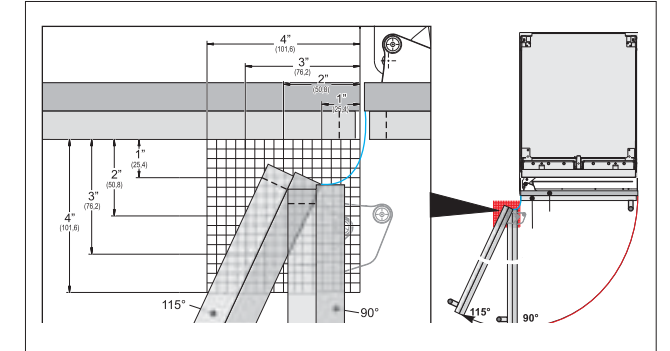

HANDLE INSTALLATION AND DIMENSIONS

PROFESSIONAL HANDLE

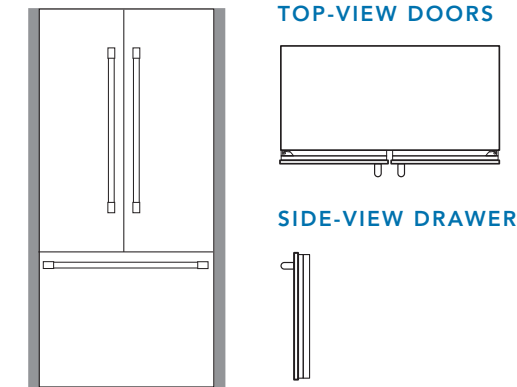

PROFESSIONAL SERIES

PR36HNDL20

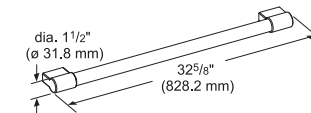
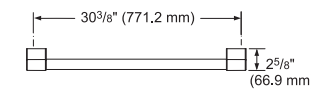

Measurements in inches (mm)

PR30HNDL20*

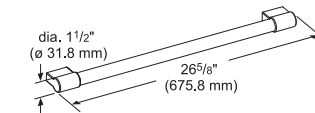
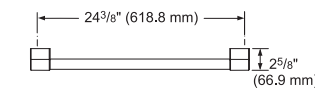

Measurements in inches (mm)

PROFESSIONAL SERIES – CLASSIC

PR36HNDL10

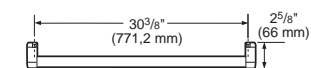

1 3/8" (39 mm)

PR30HNDL10*

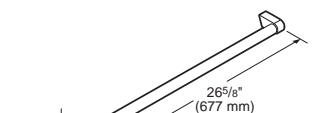
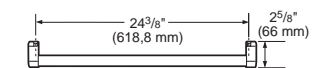

1 3/8" (39 mm)

*For use with 30" bottom freezer T30IB900SP drawer only

MASTERPIECE® HANDLE

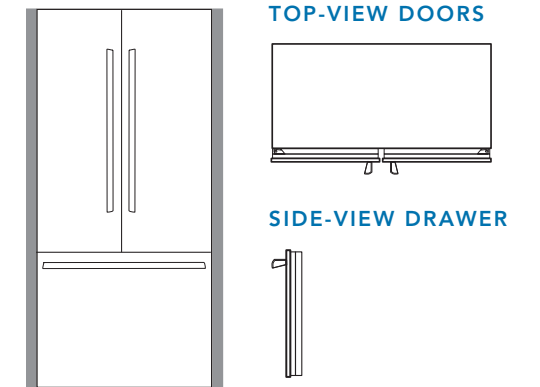

MASTERPIECE® SERIES

MS36HNDL20

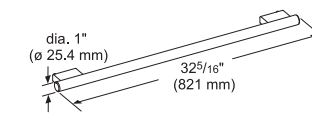
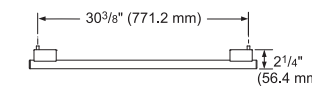

Measurements in inches (mm)

MS30HNDL20*

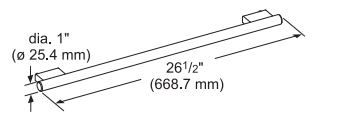
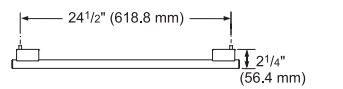

Measurements in inches (mm)

MASTERPIECE® SERIES – CLASSIC

MS36HNDL10

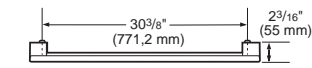

1 1/4" (31 mm)

MS30HNDL10*

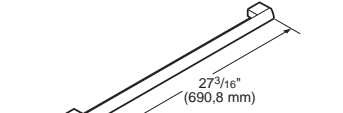
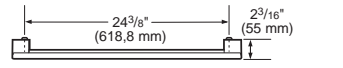

1 1/4" (31 mm)

23.5-INCH CUSTOM FRESH FOOD COLUMN
T23IR900SP

CUTOUT DIMENSIONS

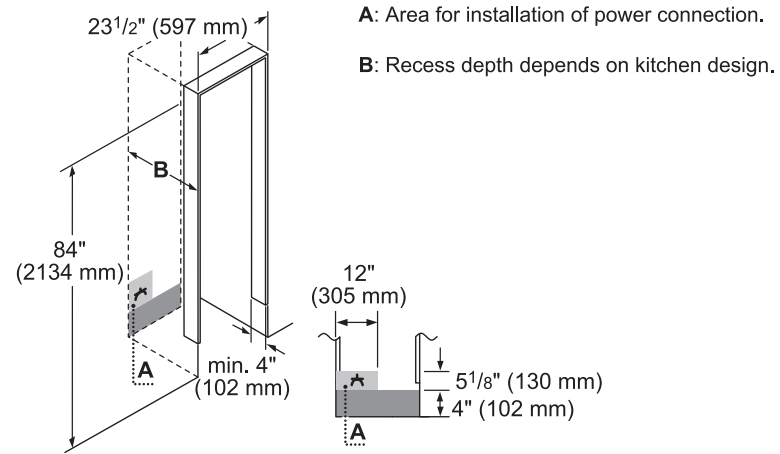

TOP VIEW CLEARANCE

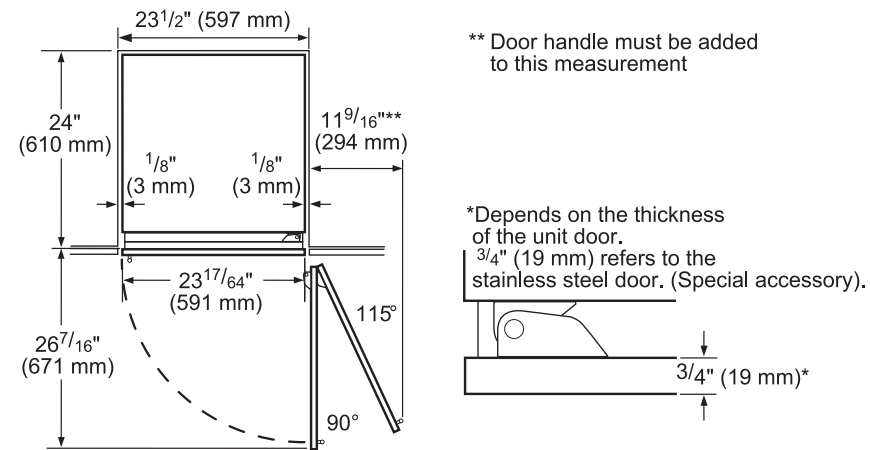

PANEL DIMENSIONS

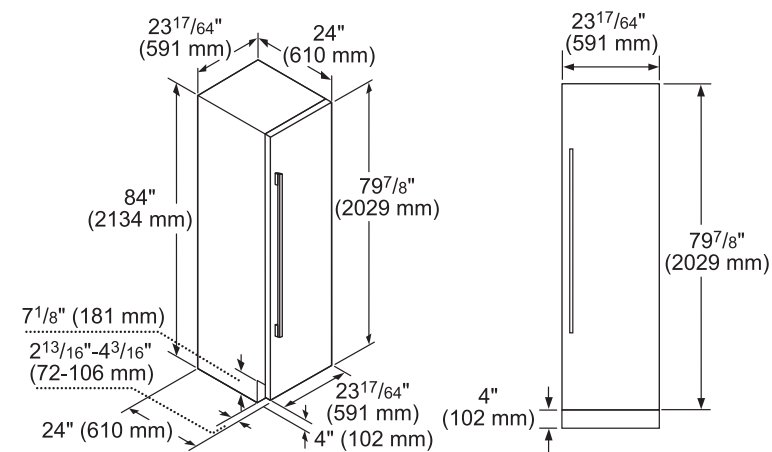

24-INCH CUSTOM FRESH FOOD COLUMN
T24IR900SP

CUTOUT DIMENSIONS

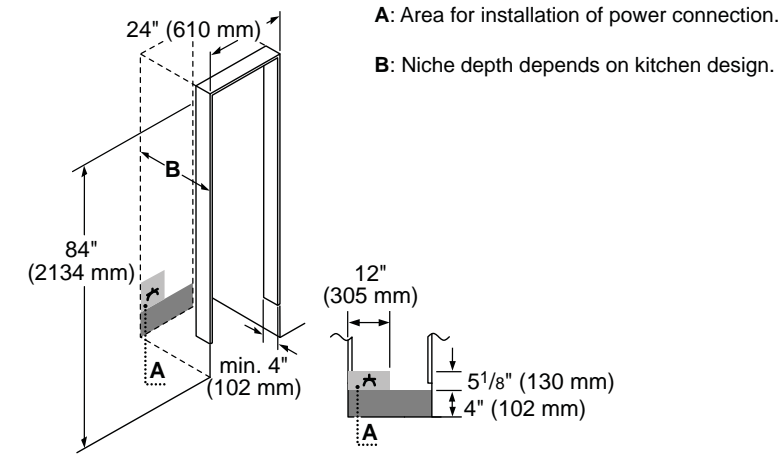

TOP VIEW CLEARANCE

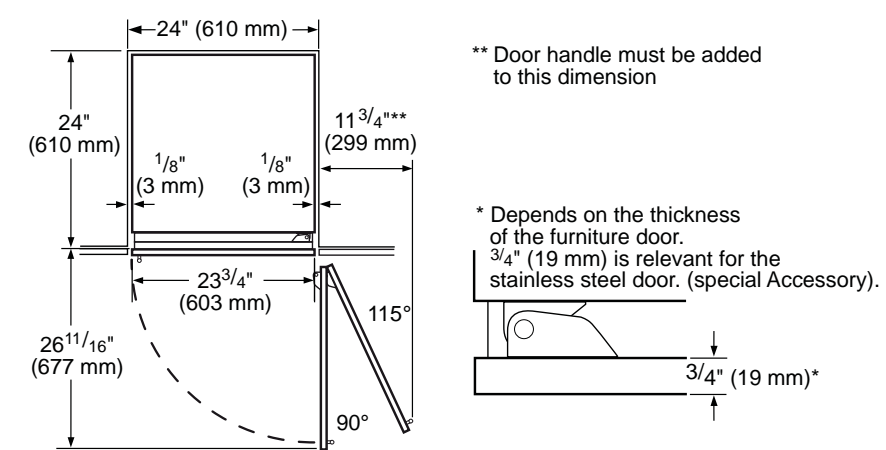

PANEL DIMENSIONS

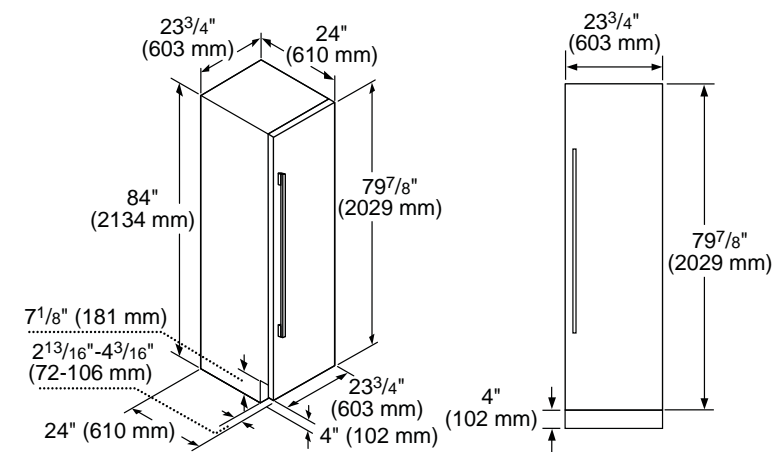

30-INCH CUSTOM FRESH FOOD COLUMN
T30IR900SP

CUTOUT DIMENSIONS

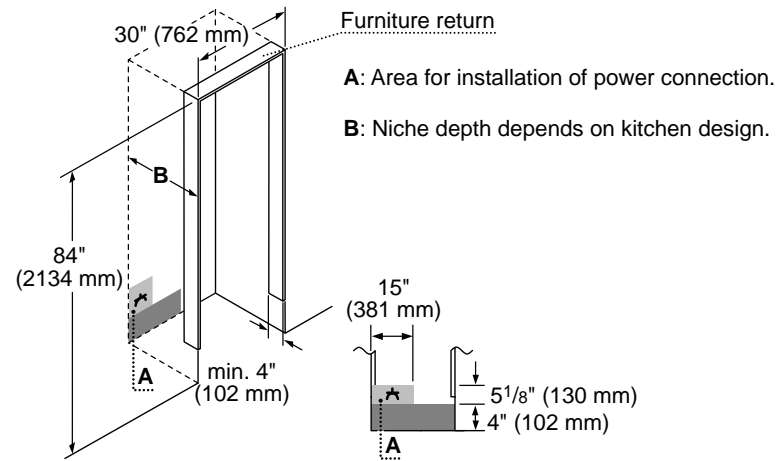

TOP VIEW CLEARANCE

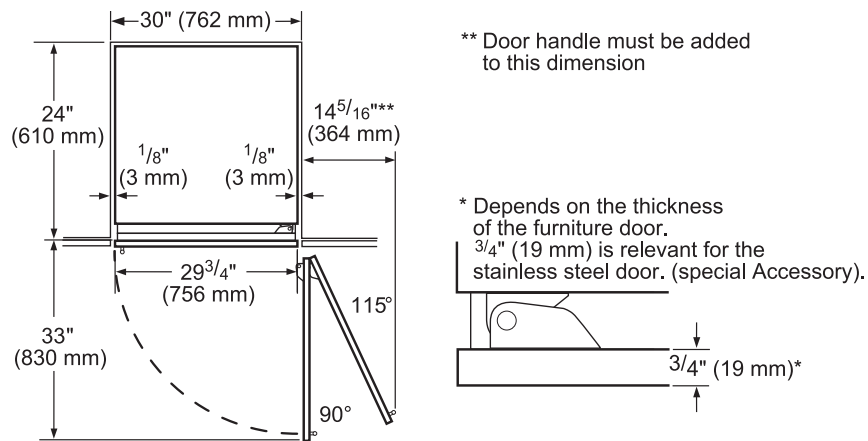

PANEL DIMENSIONS

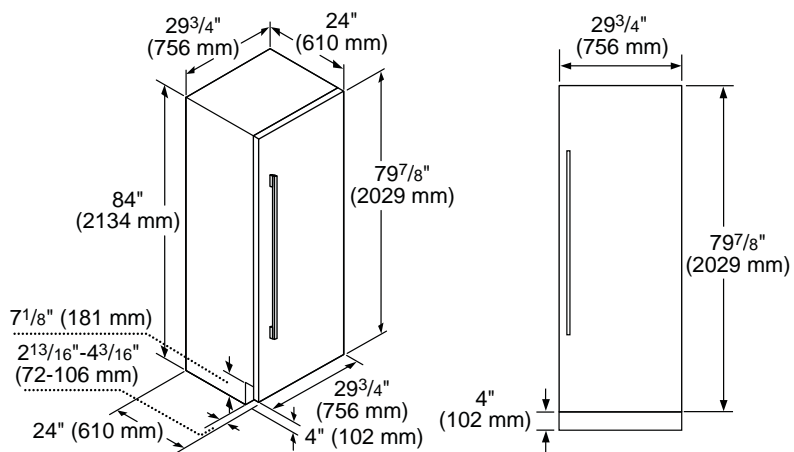

36-INCH CUSTOM FRESH FOOD COLUMN
T36IR900SP

CUTOUT DIMENSIONS

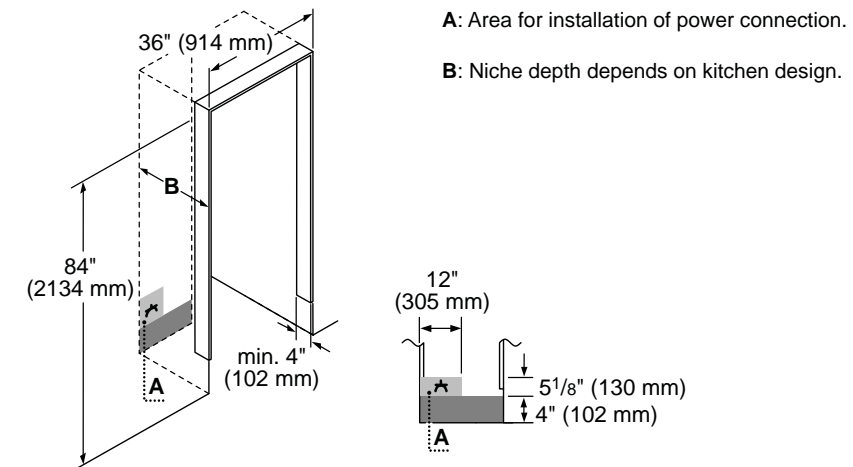

TOP VIEW CLEARANCE

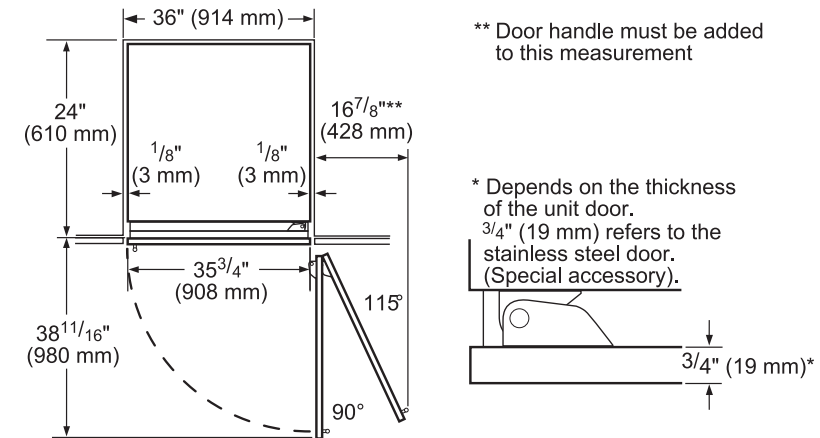

PANEL DIMENSIONS

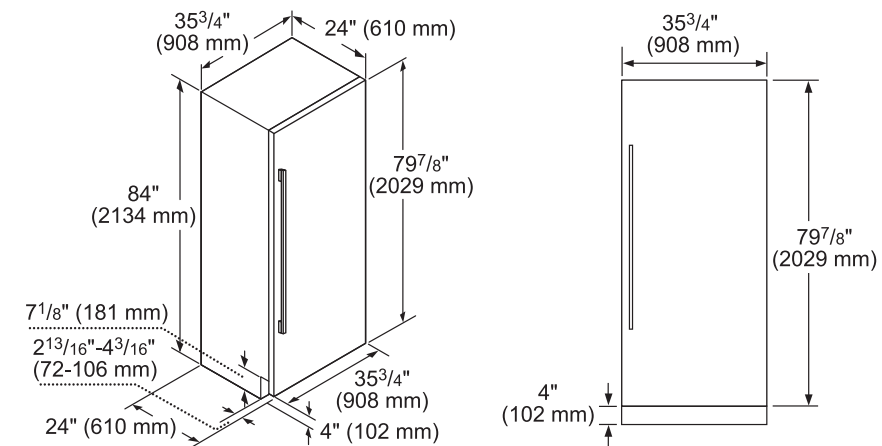

18-INCH CUSTOM FREEZER COLUMN
T18ID900RP / T18ID900LP

CUTOUT DIMENSIONS

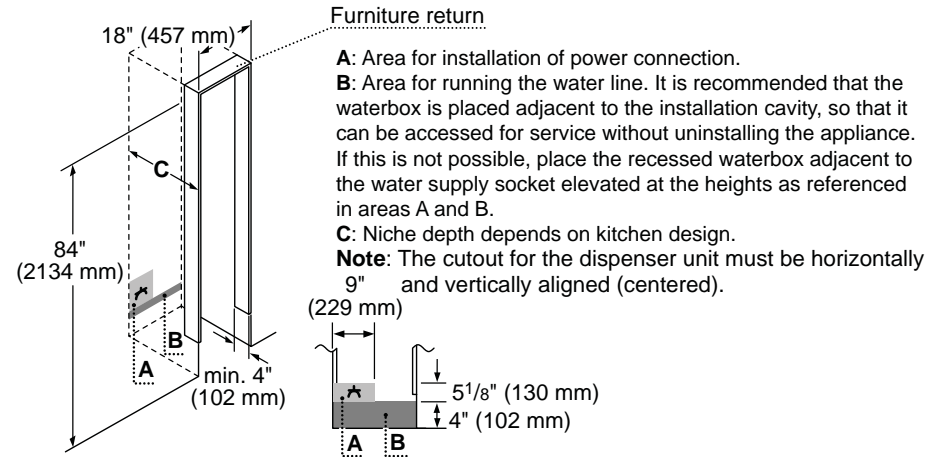

TOP VIEW CLEARANCE

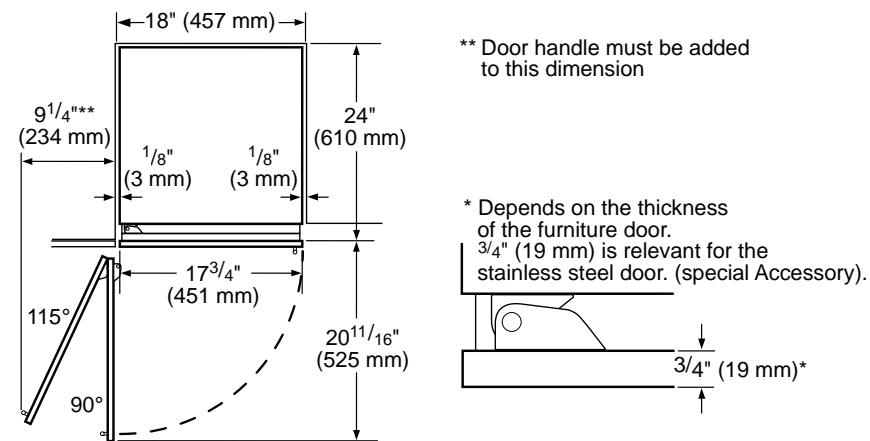
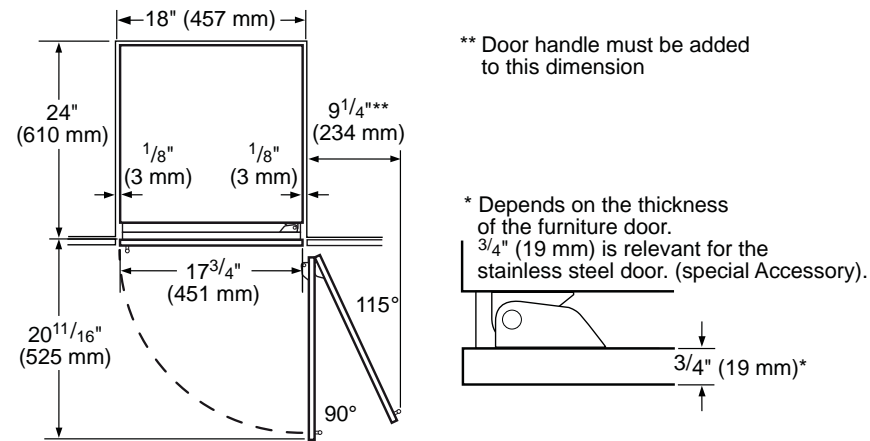

PANEL DIMENSIONS

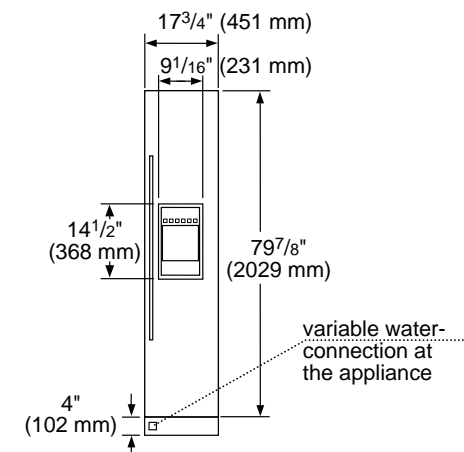
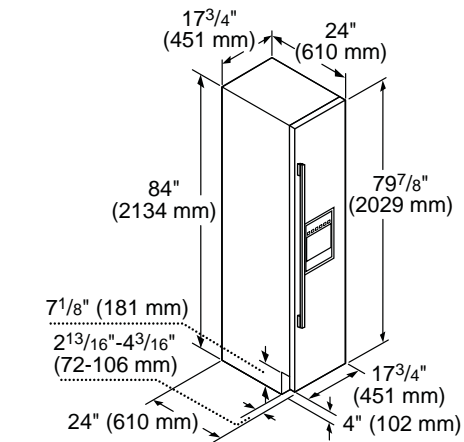

18-INCH CUSTOM FREEZER COLUMN
T18IF900SP

CUTOUT DIMENSIONS

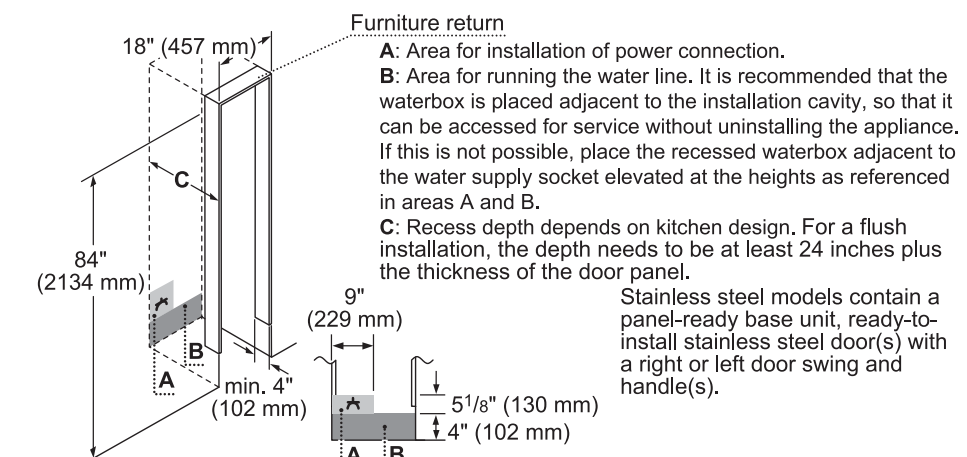

TOP VIEW CLEARANCE

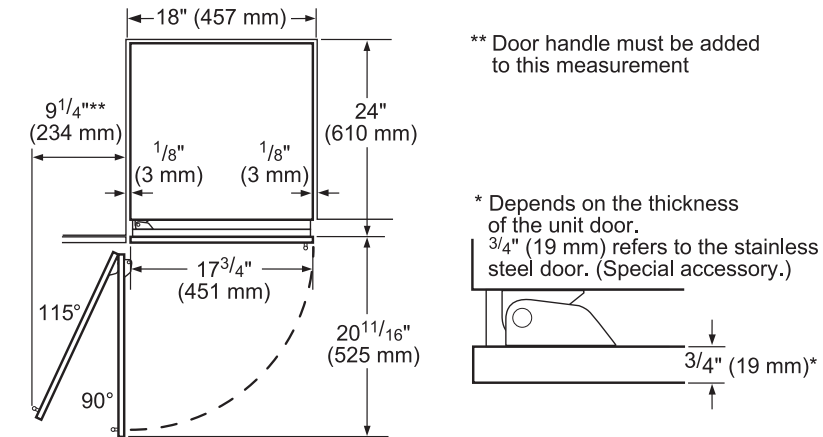

PANEL DIMENSIONS

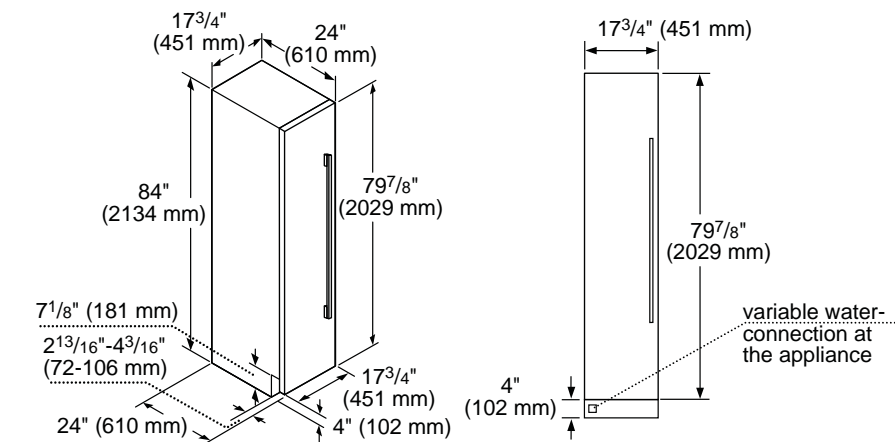

24-INCH CUSTOM FREEZER COLUMN
T24ID900RP / T24ID900LP

CUTOUT DIMENSIONS

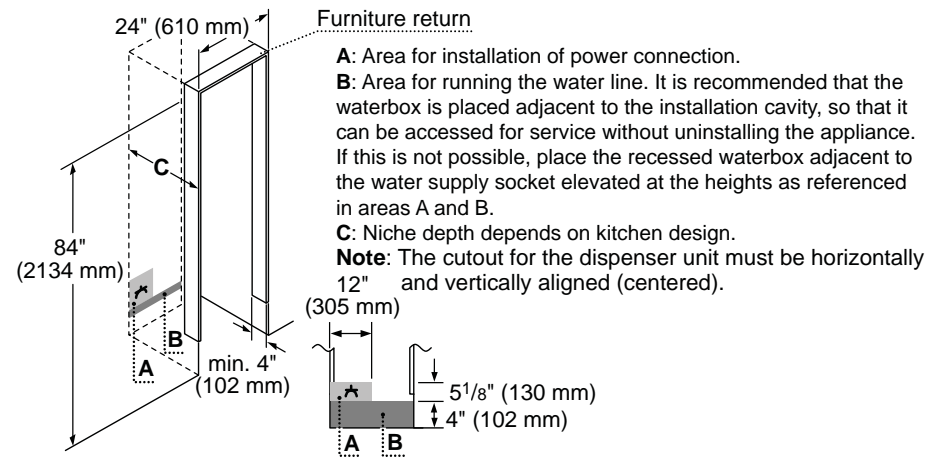

TOP VIEW CLEARANCE

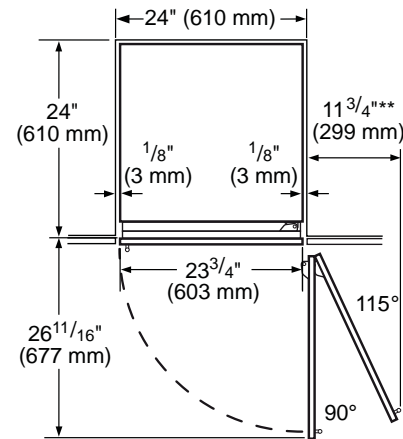

** Door handle must be added to this dimension

* Depends on the thickness of the furniture door. 3/4" (19 mm) is relevant for the stainless steel door. (special Accessory).

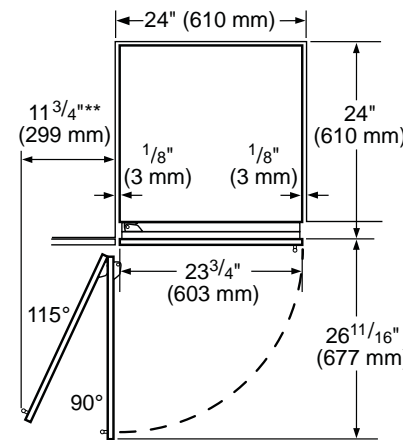
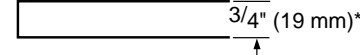

** Door handle must be added to this dimension

* Depends on the thickness of the furniture door. 3/4" (19 mm) is relevant for the stainless steel door. (special Accessory).

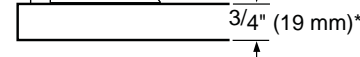

PANEL DIMENSIONS

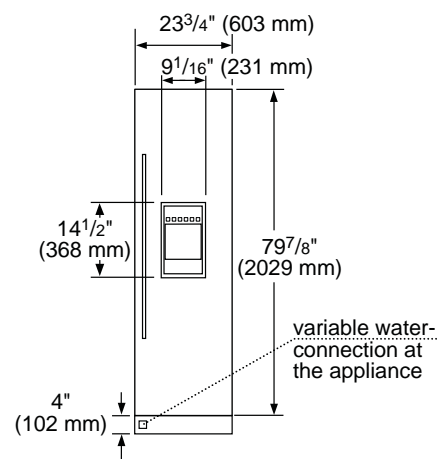
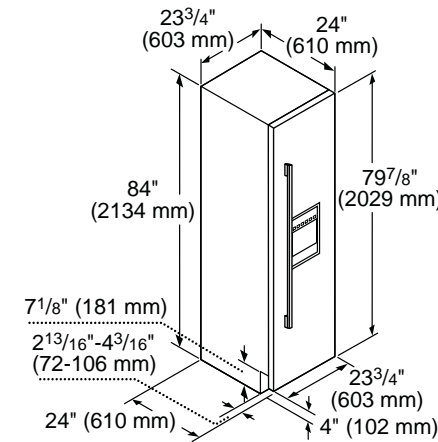

24-INCH CUSTOM FREEZER COLUMN
T24IF900SP

CUTOUT DIMENSIONS

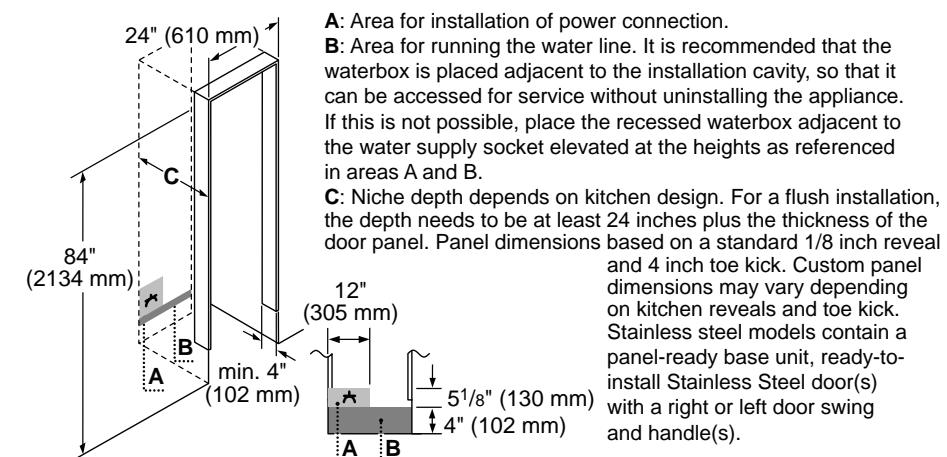

TOP VIEW CLEARANCE

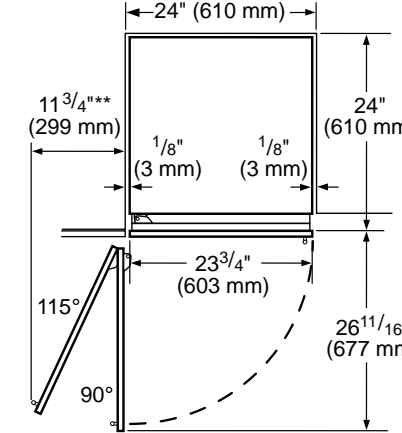

** Door handle must be added to this dimension

* Depends on the thickness of the furniture door. 3/4" (19 mm) is relevant for the stainless steel door. (special Accessory).

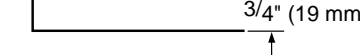

PANEL DIMENSIONS

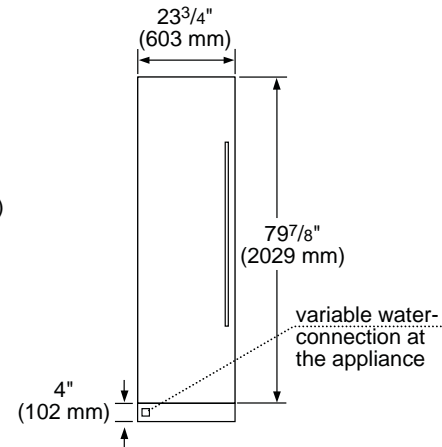
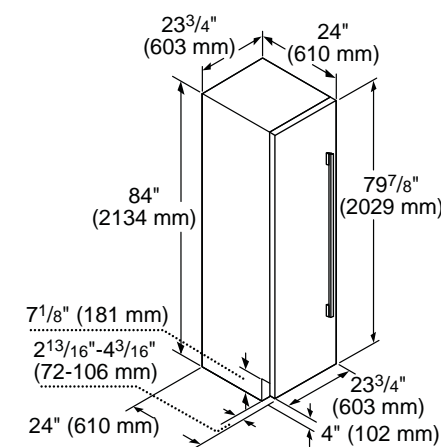

30-INCH CUSTOM FREEZER COLUMN
T30IF900SP

CUTOUT DIMENSIONS

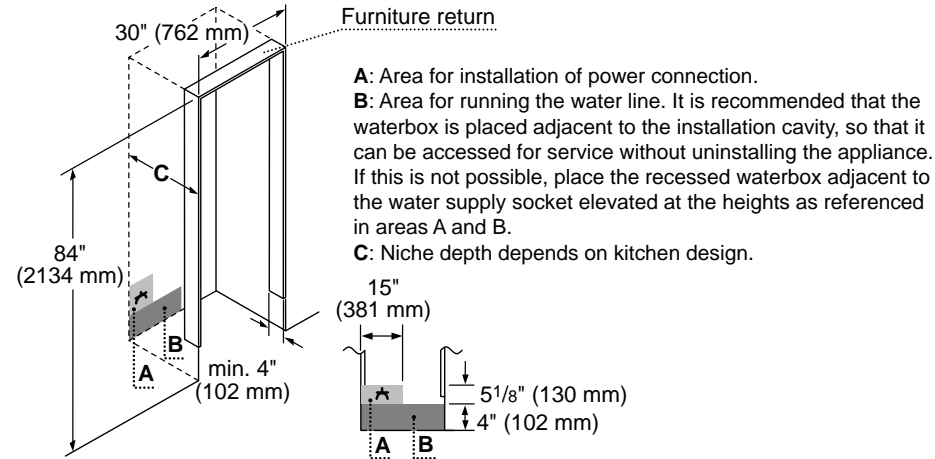

TOP VIEW CLEARANCE

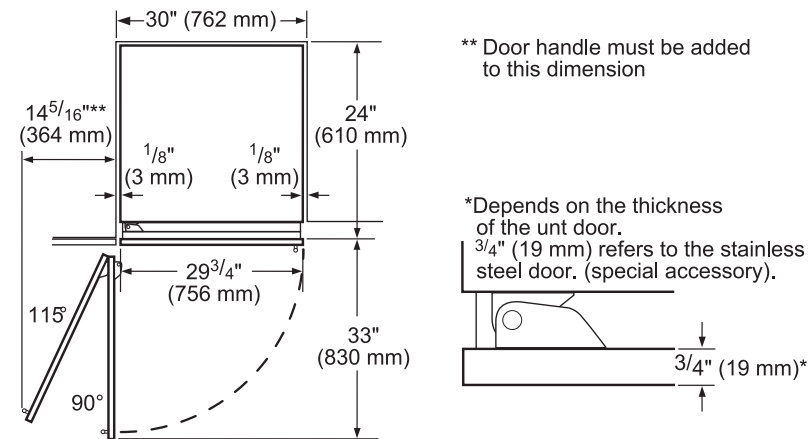

PANEL DIMENSIONS

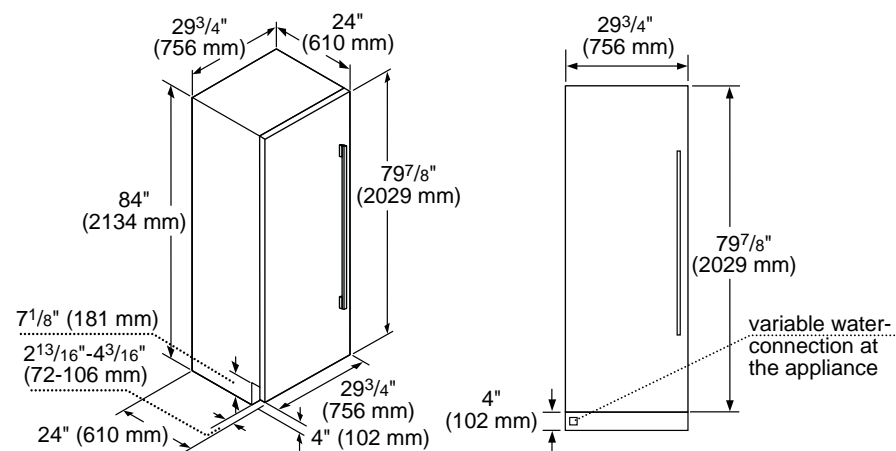

36-INCH CUSTOM FREEZER COLUMN
T36IF900SP

CUTOUT DIMENSIONS

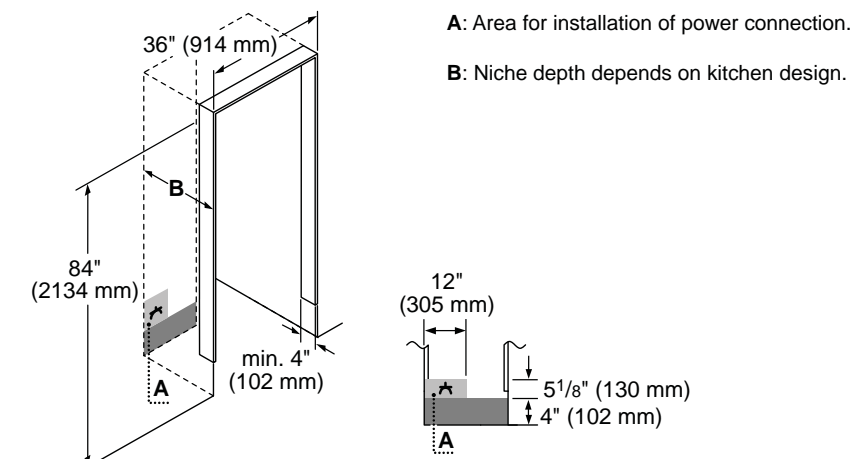

TOP VIEW CLEARANCE

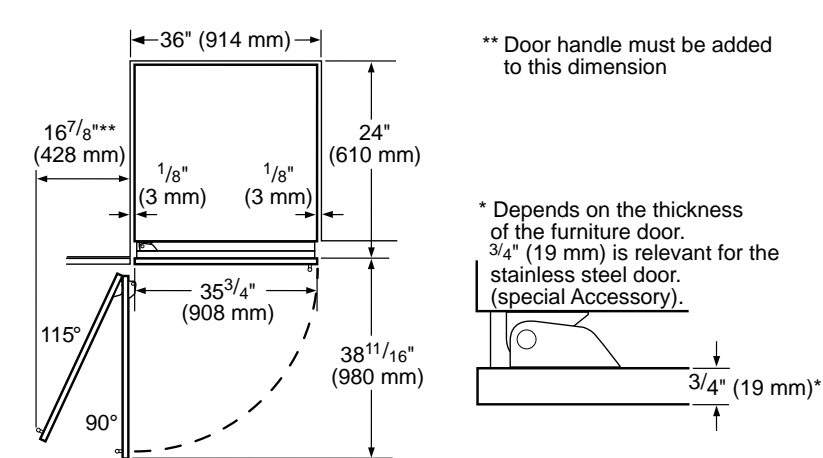

PANEL DIMENSIONS

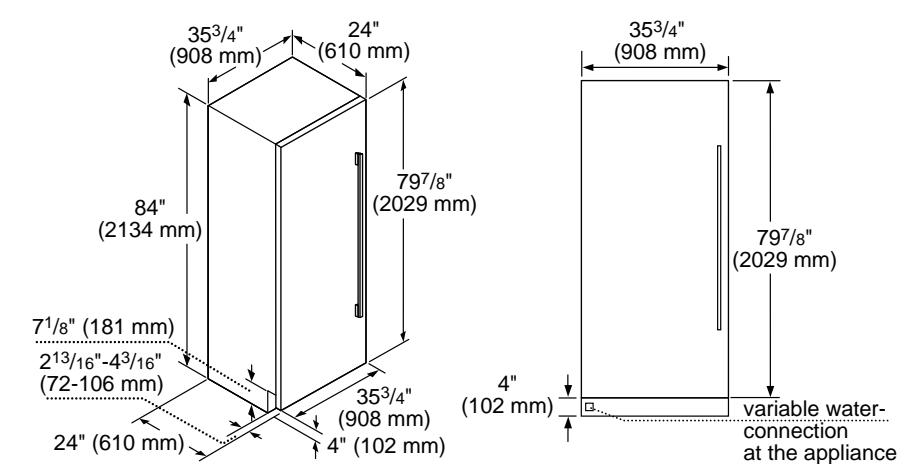

18-INCH CUSTOM WINE PRESERVATION COLUMN
T18IW900SP

CUTOUT DIMENSIONS

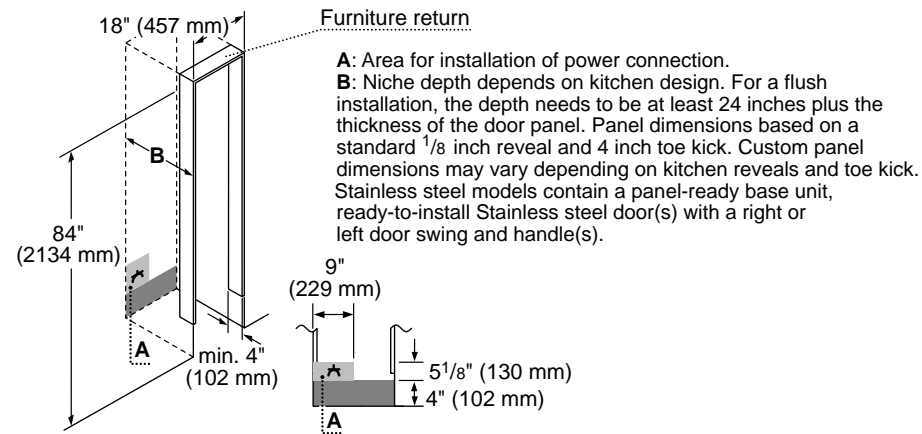

TOP VIEW CLEARANCE

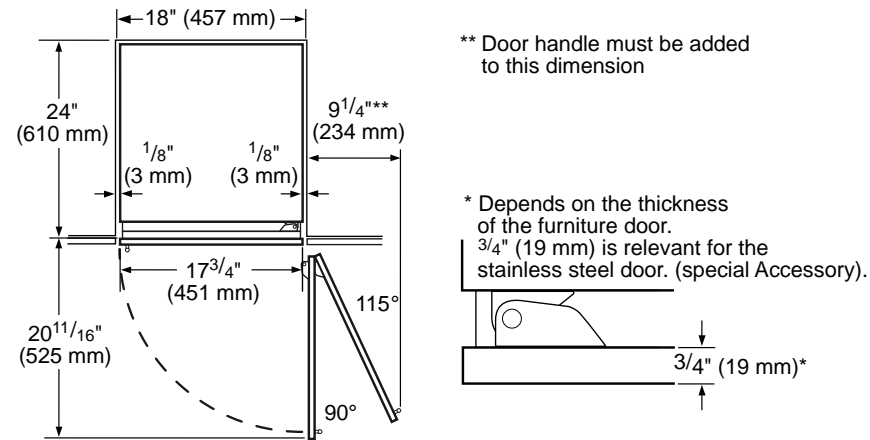

PANEL DIMENSIONS

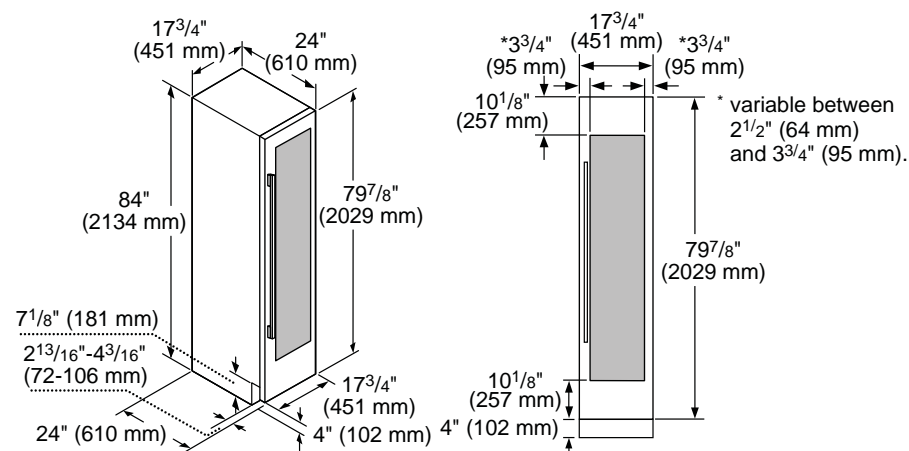

24-INCH CUSTOM WINE PRESERVATION COLUMN
T24IW900SP

CUTOUT DIMENSIONS

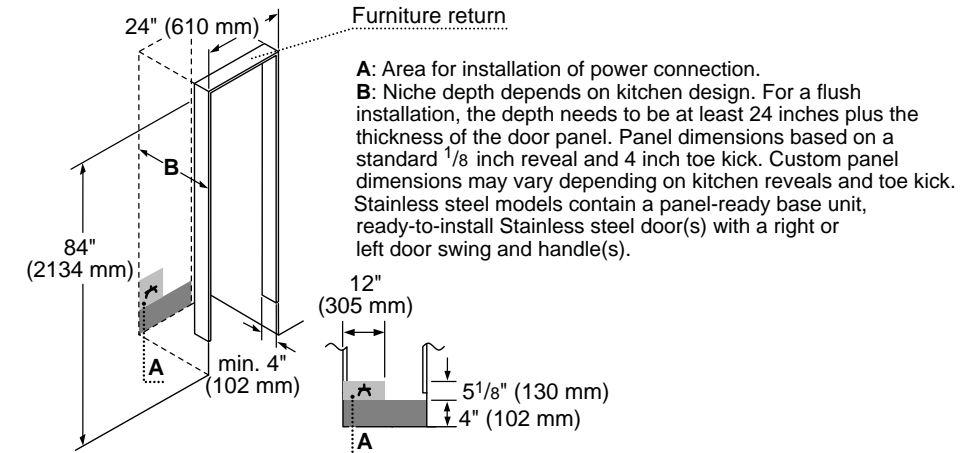

TOP VIEW CLEARANCE

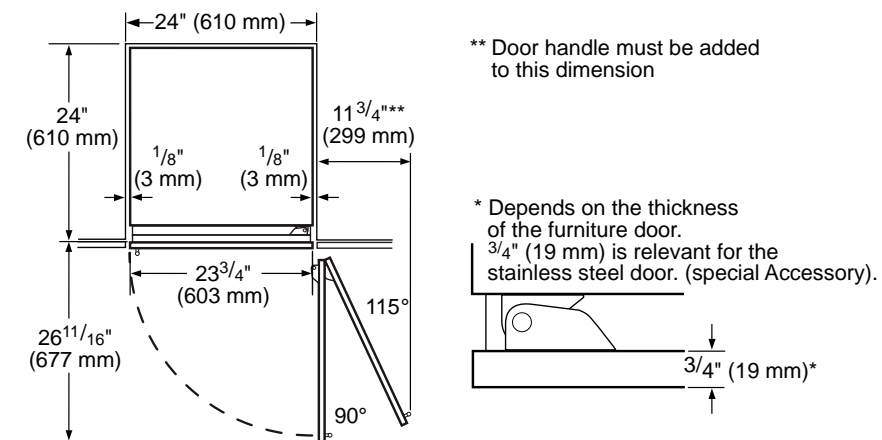

PANEL DIMENSIONS

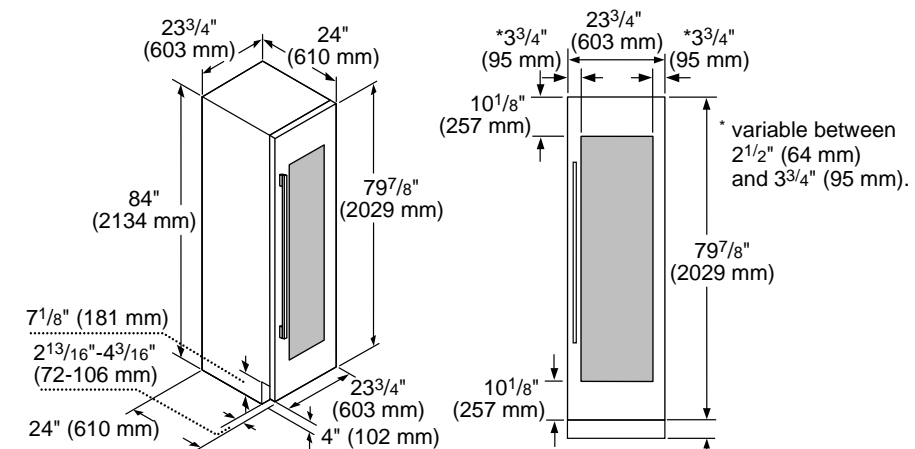

30-INCH CUSTOM 2-DOOR BOTTOM FREEZER
T30IB900SP

CUTOUT DIMENSIONS

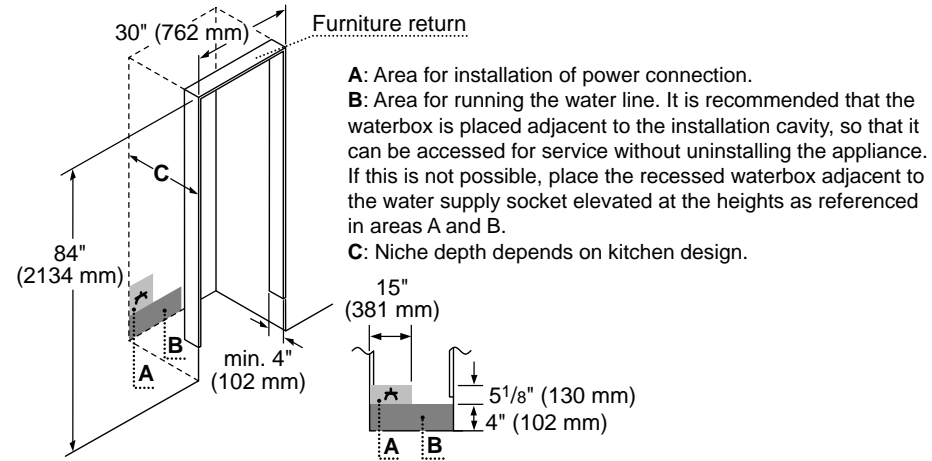

TOP VIEW CLEARANCE

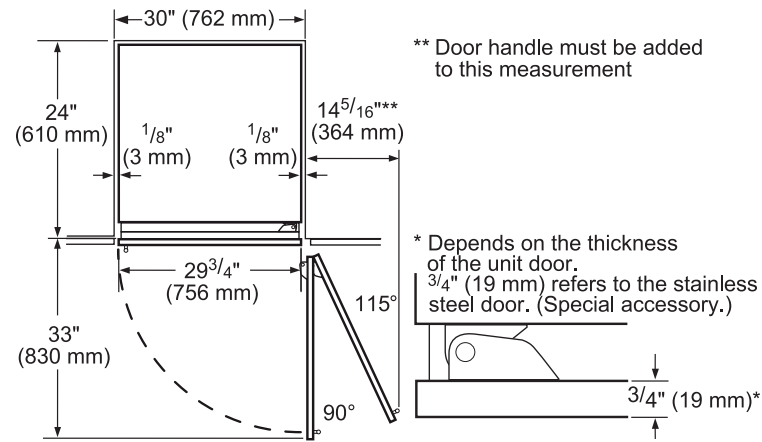

PANEL DIMENSIONS

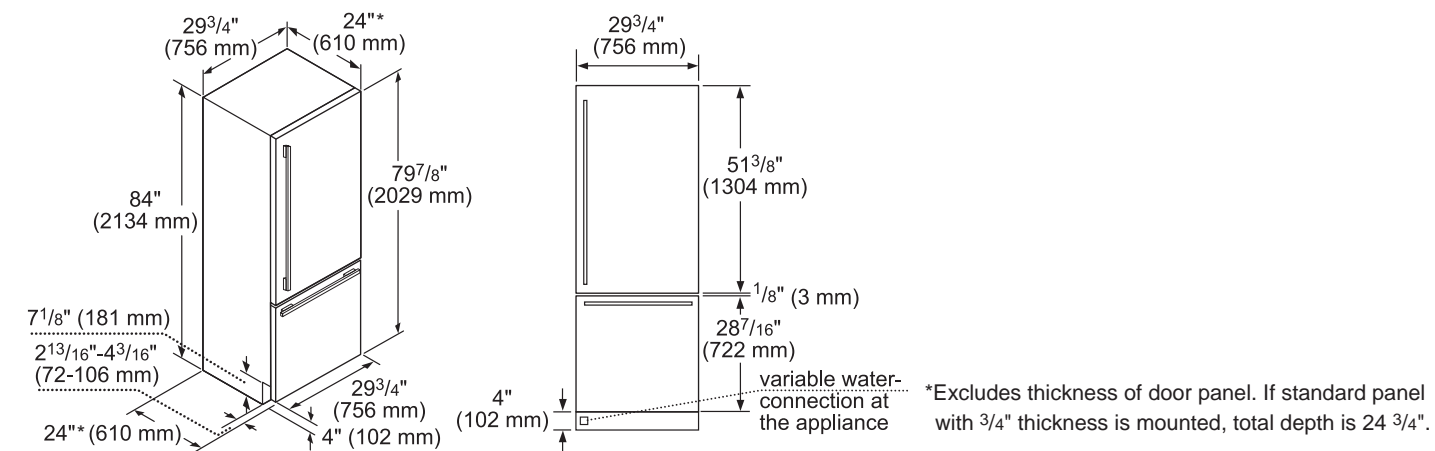

36-INCH CUSTOM 2-DOOR BOTTOM FREEZER
T36IB900SP

CUTOUT DIMENSIONS

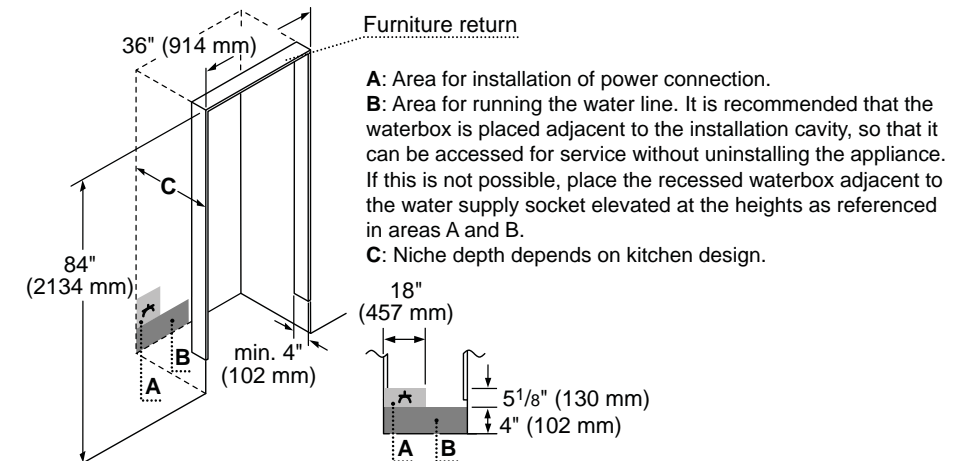

TOP VIEW CLEARANCE

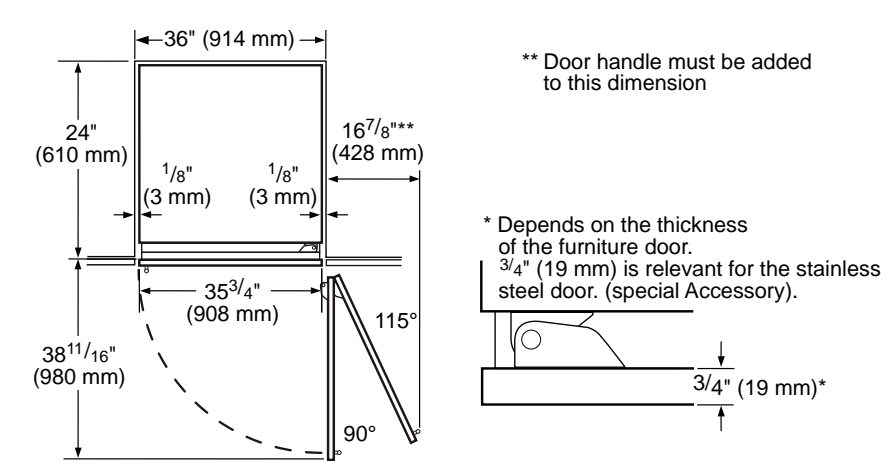

PANEL DIMENSIONS

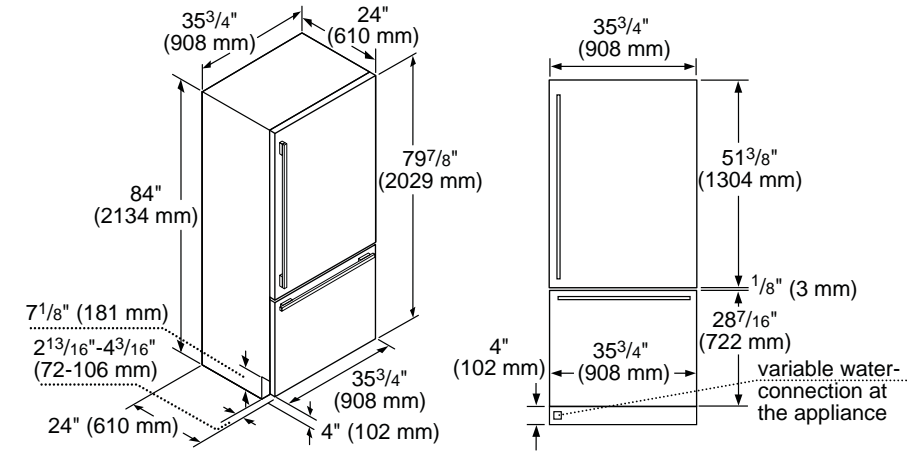

36-INCH CUSTOM FRENCH DOOR BOTTOM FREEZER
T36IT900NP

CUTOUT DIMENSIONS

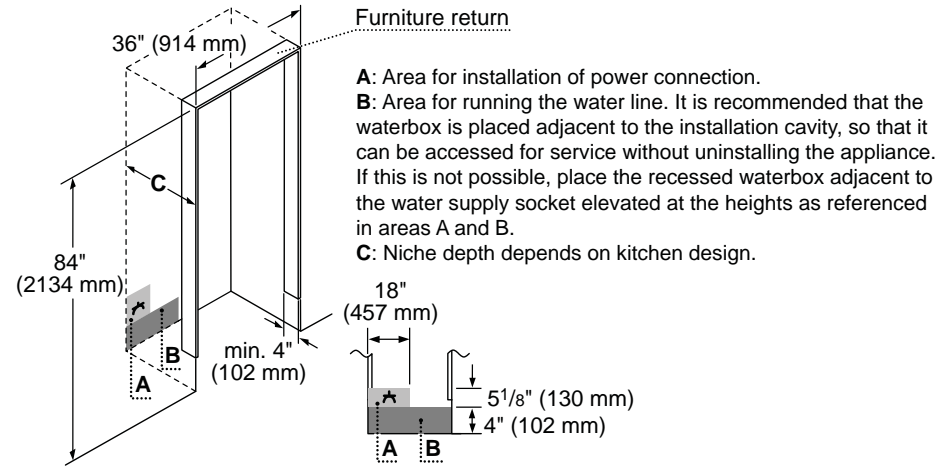

TOP VIEW CLEARANCE

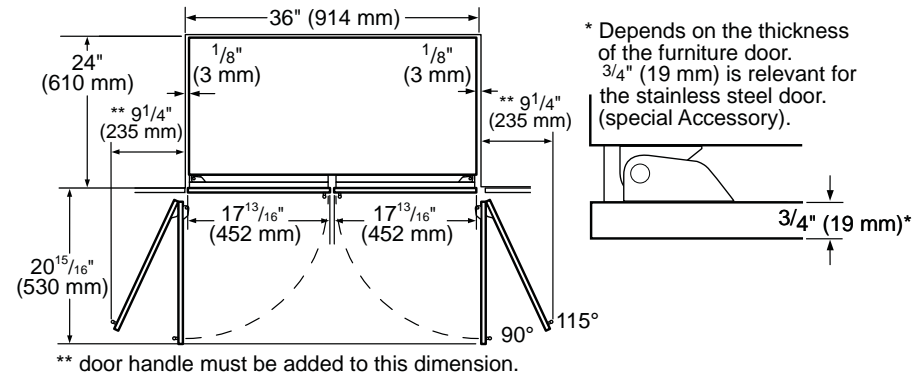

PANEL DIMENSIONS

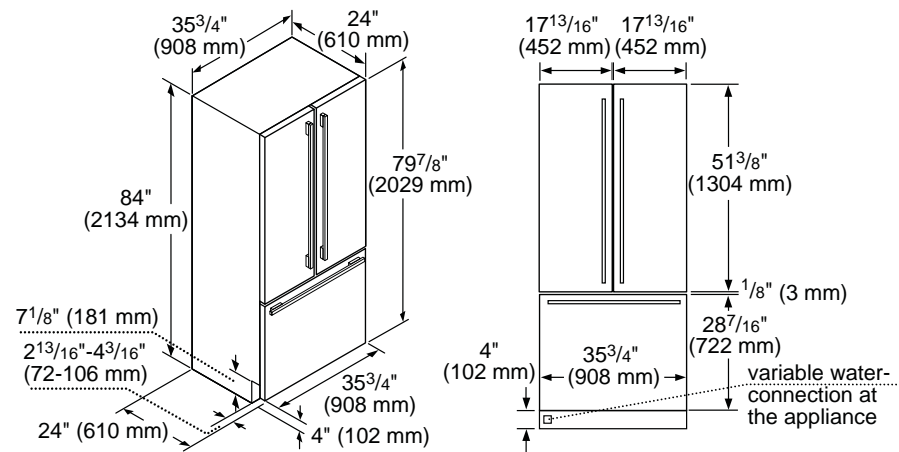

30-INCH PRE-ASSEMBLED 2-DOOR BOTTOM FREEZER
T30BB920SS / T30BB910SS

CUTOUT DIMENSIONS

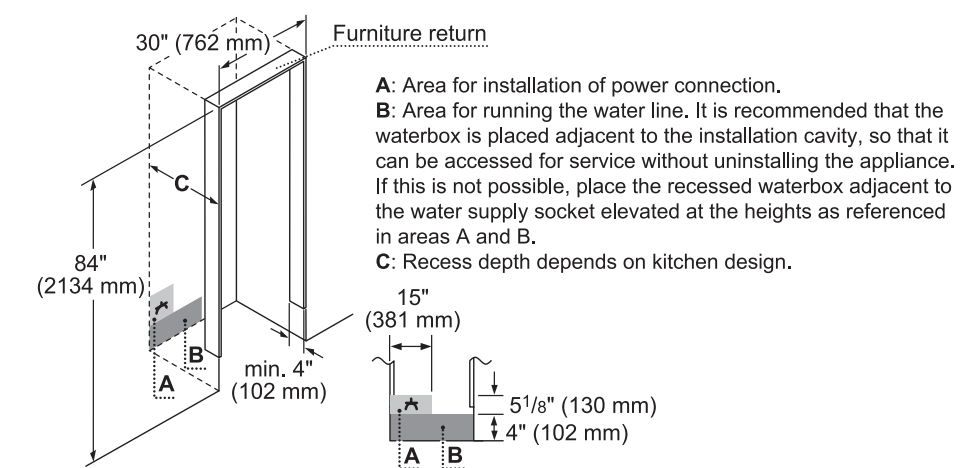

TOP VIEW CLEARANCE

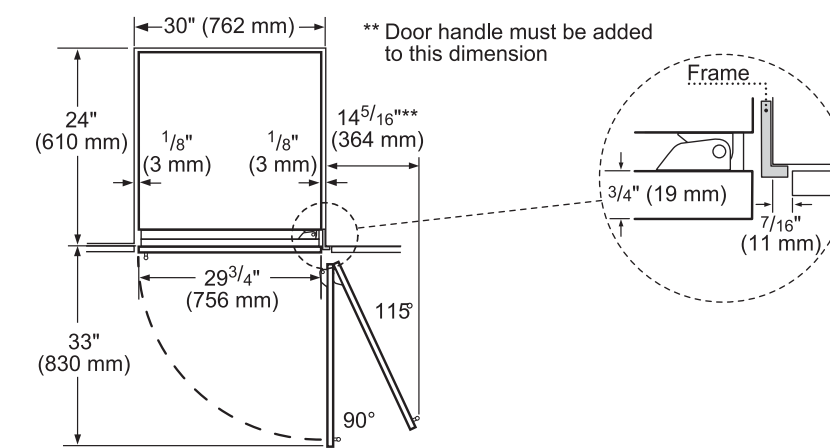

PANEL DIMENSIONS

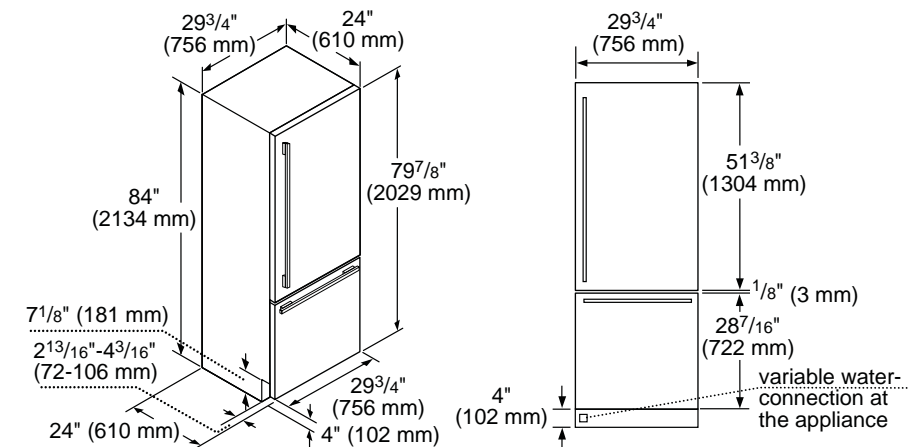

36-INCH PRE-ASSEMBLED 2-DOOR BOTTOM FREEZER
T36BB920SS / T36BB910SS

CUTOUT DIMENSIONS

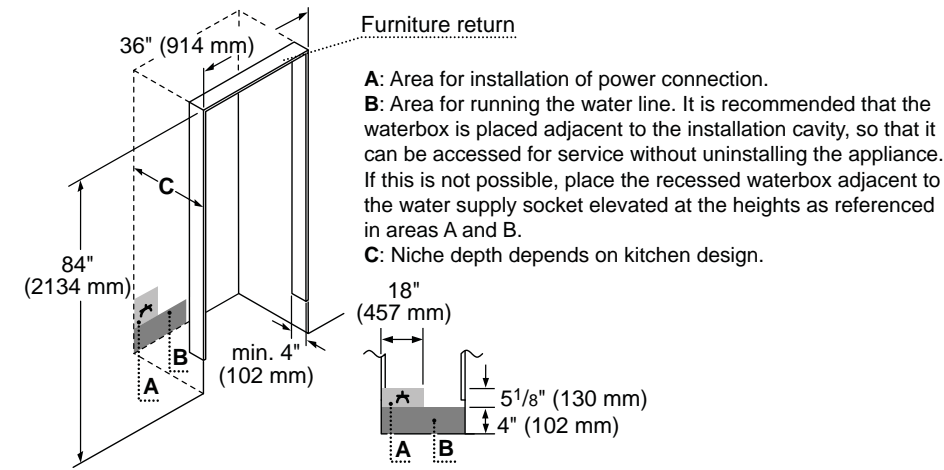

TOP VIEW CLEARANCE

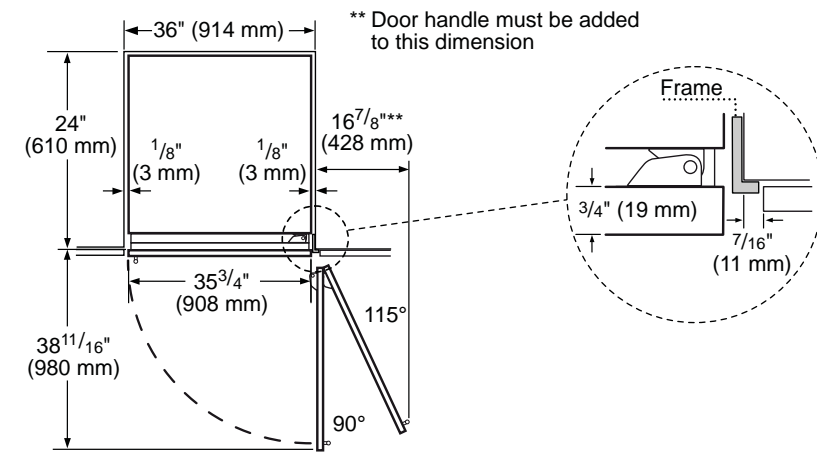

PANEL DIMENSIONS

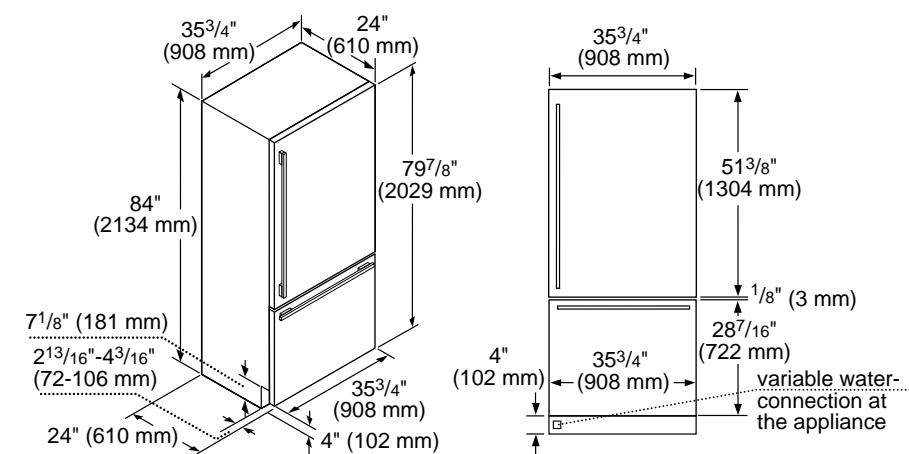

36-INCH PRE-ASSEMBLED FRENCH DOOR BOTTOM FREEZER
T36BT920NS / T36BT910NS

CUTOUT DIMENSIONS

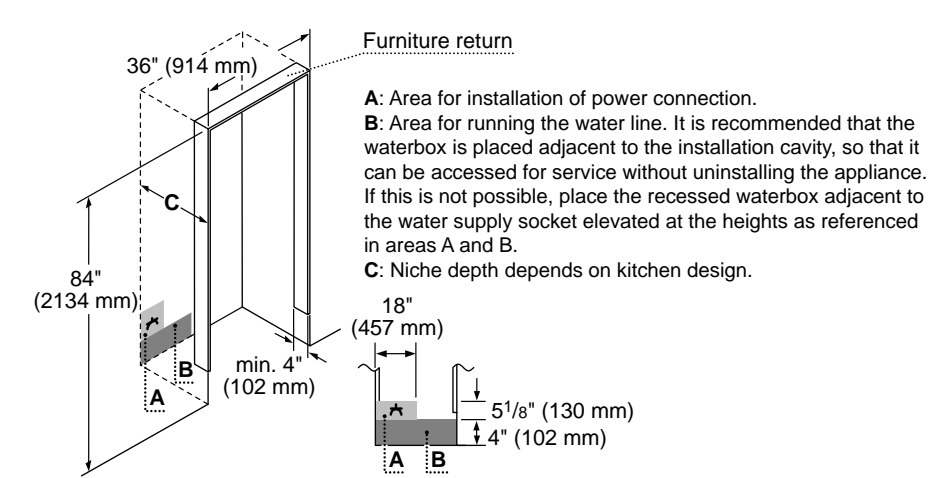

TOP VIEW CLEARANCE

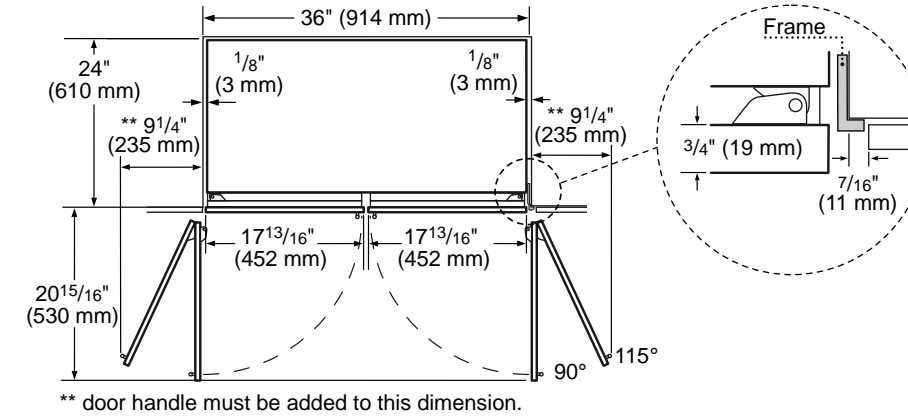

PANEL DIMENSIONS

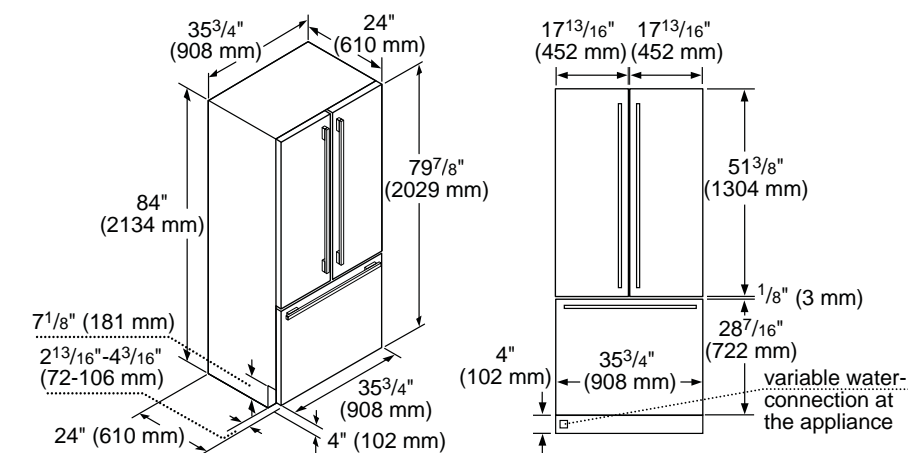



REFRIGERATION

UNDER-COUNTER

The Thermador® under-counter refrigeration collection brings complete freedom to the culinary enthusiast. The collection offers a wine reserve and a double drawer refrigerator.

Our fully flush models integrate seamlessly into 24" depth cabinetry and feature SoftClose® hinges and slides. Choose from Professional or Masterpiece® stainless steel options or design your own custom panel. This innovative collection extends the range of design possibilities inside the kitchen and out.



Under-Counter Refrigeration **COMMON FEATURES**

SOFTCLOSE® DOORS AND DRAWERS

The innovative hinge and advanced slide provide a new level of luxury with a gentle, automatic close.

LED LIGHTING

Brighter, whiter, LED lighting illuminates stored items—so that all food can be seen—and nothing remains overlooked or forgotten.

TOUCH ELECTRONIC CONTROLS

The full-width touch control panel offers precision temperature control and elegant aesthetics. A digital display and LED's clearly showcase the selected functions.



Wine Reserve with Glass Door **FEATURE HIGHLIGHTS**

FULL-EXTENSION WINE RACKS

Removable and cantilevered for adjustability, full-extension racks enhance the experience of pulling out your favorite vintage. Capped with aluminum fronts of the highest grade, the exclusive wenge hardwood racks are the ultimate luxury.

DUAL ZONE WINE STORAGE

Two adjustable zones, perfect for keeping wine at the appropriate temperatures for serving or aging.

SOFTCLOSE® DOORS

The innovative door hinges provide a new level of luxury with a gentle, automatic close. Robust and versatile, the hinge allows for a 115° door opening and can be positioned to stop at a 90° angle.

UV RESISTANT GLASS

Tinted to match the Thermador® family of products and tempered for strength, this special door suppresses dangerous ultraviolet rays that can prematurely age fine wine.

DOOR OPEN ALARM

When the door is left ajar and the temperature drops below the preferred setting, the alarm will alert you of a status change from the original setting.

Double Drawer Refrigerator **FEATURE HIGHLIGHTS**

CUSTOMIZABLE COOLING MODES

Drawers feature three easy, customizable cooling modes. A mode for every-day refrigerator items, a warmer pantry or cellar mode and a bar mode for super-chilled beverages.

CUSTOMIZABLE DRAWER DIVIDERS & SHELVING

Removable and completely customizable, robust aluminum dividers keep drawer contents neatly tucked in place. They can also be reconfigured to create custom shelving which provides two levels of drawer storage and room for platters. When using the unit as an extension to your refrigeration entertainment needs, configure the dividers to hold wine or beverage bottles for your guests.

QUICK CHILL

Crucial for optimal freshness, quick chill rapidly cools new items and helps minimize temperature fluctuations—keeping food crisp and delicious.

REMOVABLE DRAWER MAT

Each drawer includes a flexible and durable mat to ensure bottles and other delicate items do not slide when the drawer is opened and closed. This specially designed mat is removable for easy cleaning.

SOFTCLOSE® DRAWERS

The innovative drawer slides provide a new level of luxury with a gentle, automatic close.



T24UW820LS / T24UW820RS
UNDER-COUNTER WINE RESERVE WITH GLASS DOOR
 PROFESSIONAL SERIES HANDLE



GENERAL PROPERTIES	
Panel Ready	N/A
UV Resistant Glass Door	Yes
Reversible Door Swing	Left and Right Available
SoftClose® Door Hinges	Yes
Lighting	Adjustable LED Lighting
Full Width Shelves	6
Shelf Material	Wenge Hardwood w/ Aluminum Front Caps
Full Extension Wine Racks	Yes
Dual Zone Wine Storage	Yes
Door Open Alarm	Yes
Touch Electronic Controls	Yes

CAPACITY	
Number of Bottles	41

TEMPERATURE RANGES	
Upper Zone	40°F (3°C) to 52°F (10°C)
Lower Zone	52°F (11°C) to 64°F (18°C)

TECHNICAL DETAILS	
Watts (W)	150 W
Current (A)	15 Amp
Volts (V)	115 V
Frequency (Hz)	60 Hz
Power Cord Length (in.)	64"
Plug Type	120V 3-Wire

DIMENSIONS & WEIGHT	
Appliance Dimensions (H x W x D) (in.)	34 1/4" x 23 7/8" x 24"
Required Cutout Size (H x W x D) (in.)	34 3/4" - 35 1/4" x 24 3/16" x 24 9/16"
Net / Gross Weight (lbs)	190 / 205 lbs

EFFICIENCY	
Annual Energy Consumption	227 kWh

WARRANTY	
Limited, Entire Appliance, Parts and Labor on Any Part of the Refrigerator that Fails Because of a Manufacturing Defect	2 Year
Limited Warranty for Sealed Refrigeration System**; Parts and Labor	3rd to 6th Year
Limited Warranty for Sealed Refrigeration System*; Parts Only	7th to 12th Year

*Height adjustable + 1/2" (13 mm) with legs fully extended
 **Sealed refrigeration system includes compressor, evaporator, condenser, dryer / strainer and connection tubing

Also Available:
 T24UW810LS - Left Hand Door Swing with Masterpiece® Series Handle
 T24UW810RS - Right Hand Door Swing with Masterpiece® Series Handle
 T24UW800LP - Left Hand Door Swing, Custom Panel Ready
 T24UW800RP - Right Hand Door Swing, Custom Panel-Ready

FEATURES & BENEFITS

- Dual zone wine storage with adjustable temperature zones
- Full-extension wine racks
- UV resistant tempered glass door
- SoftClose® door hinges for ultra-smooth closing of the door
- LED theater lighting
- Touch electronic controls for precise temperature management

T24UW810LS / T24UW810RS
UNDER-COUNTER WINE RESERVE WITH GLASS DOOR
 MASTERPIECE® SERIES HANDLE



GENERAL PROPERTIES	
Panel Ready	N/A
UV Resistant Glass Door	Yes
Reversible Door Swing	Left and Right Available
SoftClose® Door Hinges	Yes
Lighting	Adjustable LED Lighting
Full Width Shelves	6
Shelf Material	Wenge Hardwood w/ Aluminum Front Caps
Full Extension Wine Racks	Yes
Dual Zone Wine Storage	Yes
Door Open Alarm	Yes
Touch Electronic Controls	Yes

CAPACITY	
Number of Bottles	41

TEMPERATURE RANGES	
Upper Zone	40°F (3°C) to 52°F (10°C)
Lower Zone	52°F (11°C) to 64°F (18°C)

TECHNICAL DETAILS	
Watts (W)	150 W
Current (A)	15 Amp
Volts (V)	115 V
Frequency (Hz)	60 Hz
Power Cord Length (in.)	64"
Plug Type	120V 3-Wire

DIMENSIONS & WEIGHT	
Appliance Dimensions (H x W x D) (in.)	34 1/4" x 23 7/8" x 24"
Required Cutout Size (H x W x D) (in.)	34 3/4" - 35 1/4" x 24 3/16" x 24 9/16"
Net / Gross Weight (lbs)	190 / 205 lbs

EFFICIENCY	
Annual Energy Consumption	227 kWh

WARRANTY	
Limited, Entire Appliance, Parts and Labor on Any Part of the Refrigerator that Fails Because of a Manufacturing Defect	2 Year
Limited Warranty for Sealed Refrigeration System**; Parts and Labor	3rd to 6th Year
Limited Warranty for Sealed Refrigeration System*; Parts Only	7th to 12th Year

*Height adjustable + 1/2" (13 mm) with legs fully extended
 **Sealed refrigeration system includes compressor, evaporator, condenser, dryer / strainer and connection tubing

Also Available:
 T24UW820LS - Left Hand Door Swing with Professional Series Handle
 T24UW820RS - Right Hand Door Swing with Professional Series Handle
 T24UW800LP - Left Hand Door Swing, Custom Panel Ready
 T24UW800RP - Right Hand Door Swing, Custom Panel-Ready

FEATURES & BENEFITS

- Dual zone wine storage with adjustable temperature zones
- Full-extension wine racks
- UV resistant tempered glass door
- SoftClose® door hinges for ultra-smooth closing of the door
- LED theater lighting
- Touch electronic controls for precise temperature management

T24UW800LP / T24UW800RP

UNDER-COUNTER WINE RESERVE WITH GLASS DOOR

CUSTOM PANEL-READY



GENERAL PROPERTIES	
Panel Ready	Yes
UV Resistant Glass Door	Yes
Reversible Door Swing	Left and Right Available
SoftClose® Door Hinges	Yes
Lighting	Adjustable LED Lighting
Full Width Shelves	6
Shelf Material	Wenge Hardwood w/ Aluminum Front Caps
Full Extension Wine Racks	Yes
Dual Zone Wine Storage	Yes
Door Open Alarm	Yes
Touch Electronic Controls	Yes

CAPACITY	
Number of Bottles	41

TEMPERATURE RANGES	
Upper Zone	40°F (3°C) to 52°F (10°C)
Lower Zone	52°F (11°C) to 64°F (18°C)

TECHNICAL DETAILS	
Watts (W)	150 W
Current (A)	15 Amp
Volts (V)	115 V
Frequency (Hz)	60 Hz
Power Cord Length (in.)	64"
Plug Type	120V 3-Wire

DIMENSIONS & WEIGHT	
Appliance Dimensions (H x W x D) (in.)	34 1/4" x 23 7/8" x 24"
Required Cutout Size (H x W x D) (in.)	34 3/4" - 35 1/4" x 24 3/16" x 24 9/16"
Net / Gross Weight (lbs)	190 / 205 lbs

EFFICIENCY	
Annual Energy Consumption	227 kWh

WARRANTY	
Limited, Entire Appliance, Parts and Labor on Any Part of the Refrigerator that Fails Because of a Manufacturing Defect	2 Year
Limited Warranty for Sealed Refrigeration System**; Parts and Labor	3rd to 6th Year
Limited Warranty for Sealed Refrigeration System**; Parts Only	7th to 12th Year

*Height adjustable + 1/2" (13 mm) with legs fully extended
 **Sealed refrigeration system includes compressor, evaporator, condenser, dryer / strainer and connection tubing

Also Available:
 T24UW820LS - Left Hand Door Swing with Professional Series Handle
 T24UW820RS - Right Hand Door Swing with Professional Series Handle
 T24UW810LS - Left Hand Door Swing with Masterpiece® Series Handle
 T24UW810RS - Right Hand Door Swing with Masterpiece® Series Handle

FEATURES & BENEFITS

- Dual zone wine storage with adjustable temperature zones
- Full-extension wine racks
- UV resistant tempered glass door
- SoftClose® door hinges for ultra-smooth closing of the door
- LED theater lighting
- Touch electronic controls for precise temperature management

T24UR820DS

UNDER-COUNTER DOUBLE DRAWER REFRIGERATOR

PROFESSIONAL SERIES HANDLE



GENERAL PROPERTIES	
SoftClose® Drawers	Yes
Lighting	LED Lighting
Customizable Aluminum Dividers / Shelving	Yes
Removable Drawer Mats	Yes
Full Extension Drawers	Yes
Drawer Open Alarm	Yes
Quick Chill	Yes
Touch Electronic Controls	Yes

CAPACITY	
Total Unit Gross Capacity (cu. ft.) - AHAM	5 cu. ft.

TEMPERATURE RANGES	
Refrigerator	33°F (0.5°C) to 58°F (14.5°C)
Pre-Set Cooling Modes	Refrigerator 37°F (3°C) Pantry 53°F (12°C) Bar 34°F (1°C)
Quick Chill	Yes

TECHNICAL DETAILS	
Watts (W)	150 W
Current (A)	15 Amp
Volts (V)	115 V
Frequency (Hz)	60 Hz
Power Cord Length (in.)	64"
Plug Type	120V 3-Wire

DIMENSIONS & WEIGHT	
Appliance Dimensions (H x W x D) (in.)	34 1/4" x 23 7/8" x 24"
Required Cutout Size (H x W x D) (in.)	34 3/4" - 35 1/4" x 24 3/16" x 24 9/16"
Net / Gross Weight (lbs)	160 / 174 lbs

EFFICIENCY	
ENERGY STAR® Qualified	No
Annual Energy Consumption	304 kWh

WARRANTY	
Limited, Entire Appliance, Parts and Labor on Any Part of the Refrigerator that Fails Because of a Manufacturing Defect	2 Year
Limited Warranty for Sealed Refrigeration System**; Parts and Labor	3rd to 6th Year
Limited Warranty for Sealed Refrigeration System**; Parts Only	7th to 12th Year

*Height adjustable + 1/2" (13 mm) with legs fully extended
 **Sealed refrigeration system includes compressor, evaporator, condenser, dryer / strainer and connection tubing

Also Available:
 T24UR810DS - with Masterpiece® Series Handle
 T24UR800DP - Custom Panel-Ready

FEATURES & BENEFITS

- Customizable cooling modes—Fridge, Pantry and Bar
- SoftClose® drawers for ultra-smooth closing
- Customizable drawer dividers and shelving
- Quick Chill
- LED Lighting
- Drawer mats keep items from sliding and remove for easy cleaning
- Touch electronic controls for precise temperature management

T24UR810DS
UNDER-COUNTER DOUBLE DRAWER REFRIGERATOR
 MASTERPIECE® SERIES HANDLE



Also Available:
 T24UR820DS - with Professional Series Handle
 T24UR800DP - Custom Panel-Ready

GENERAL PROPERTIES	
SoftClose® Drawers	Yes
Lighting	LED Lighting
Customizable Aluminum Dividers / Shelving	Yes
Removable Drawer Mats	Yes
Full Extension Drawers	Yes
Drawer Open Alarm	Yes
Quick Chill	Yes
Touch Electronic Controls	Yes
CAPACITY	
Total Unit Gross Capacity (cu. ft.) - AHAM	5 cu. ft.
TEMPERATURE RANGES	
Refrigerator	33°F (0.5°C) to 58°F (14.5°C)
Pre-Set Cooling Modes	Refrigerator 37°F (3°C) Pantry 53°F (12°C) Bar 34°F (1°C)
Quick Chill	Yes
TECHNICAL DETAILS	
Watts (W)	150 W
Current (A)	15 Amp
Volts (V)	115 V
Frequency (Hz)	60 Hz
Power Cord Length (in.)	64"
Plug Type	120V 3-Wire
DIMENSIONS & WEIGHT	
Appliance Dimensions (H x W x D) (in.)	34 1/4" x 23 7/8" x 24"
Required Cutout Size (H x W x D) (in.)	34 3/4" - 35 1/4" x 24 3/16" x 24 9/16"
Net / Gross Weight (lbs)	160 / 174 lbs
EFFICIENCY	
ENERGY STAR® Qualified	No
Annual Energy Consumption	304 kWh
WARRANTY	
Limited, Entire Appliance, Parts and Labor on Any Part of the Refrigerator that Fails Because of a Manufacturing Defect	2 Year
Limited Warranty for Sealed Refrigeration System*; Parts and Labor	3rd to 6th Year
Limited Warranty for Sealed Refrigeration System*; Parts Only	7th to 12th Year

*Height adjustable + 1/2" (13 mm) with legs fully extended
 **Sealed refrigeration system includes compressor, evaporator, condenser, dryer / strainer and connection tubing

FEATURES & BENEFITS

- Customizable cooling modes—Fridge, Pantry and Bar
- SoftClose® drawers for ultra-smooth closing
- Customizable drawer dividers and shelving
- Quick Chill
- LED Lighting
- Drawer mats keep items from sliding and remove for easy cleaning
- Touch electronic controls for precise temperature management

T24UR800DP
UNDER-COUNTER DOUBLE DRAWER REFRIGERATOR
 CUSTOM PANEL-READY



Also Available:
 T24UR820DS - with Professional Series Handle
 T24UR810DS - with Masterpiece® Series Handle

FEATURES & BENEFITS

- Customizable cooling modes—Fridge, Pantry and Bar
- SoftClose® drawers for ultra-smooth closing
- Customizable drawer dividers and shelving
- Quick Chill
- LED Lighting
- Drawer mats keep items from sliding and remove for easy cleaning
- Touch electronic controls for precise temperature management

GENERAL PROPERTIES	
Panel Ready	Yes
SoftClose® Drawers	Yes
Lighting	LED Lighting
Customizable Aluminum Dividers / Shelving	Yes
Removable Drawer Mats	Yes
Full Extension Drawers	Yes
Drawer Open Alarm	Yes
Quick Chill	Yes
Touch Electronic Controls	Yes
CAPACITY	
Total Unit Gross Capacity (cu. ft.) - AHAM	5 cu. ft.
TEMPERATURE RANGES	
Refrigerator	33°F (0.5°C) to 58°F (14.5°C)
Pre-Set Cooling Modes	Refrigerator 37°F (3°C) Pantry 53°F (12°C) Bar 34°F (1°C)
Quick Chill	Yes
TECHNICAL DETAILS	
Watts (W)	150 W
Current (A)	15 Amp
Volts (V)	115 V
Frequency (Hz)	60 Hz
Power Cord Length (in.)	64"
Plug Type	120V 3-Wire
DIMENSIONS & WEIGHT	
Appliance Dimensions (H x W x D) (in.)	34 1/4" x 23 7/8" x 24"
Required Cutout Size (H x W x D) (in.)	34 3/4" - 35 1/4" x 24 3/16" x 24 9/16"
Net / Gross Weight (lbs)	160 / 174 lbs
EFFICIENCY	
ENERGY STAR® Qualified	No
Annual Energy Consumption	304 kWh
WARRANTY	
Limited, Entire Appliance, Parts and Labor on Any Part of the Refrigerator that Fails Because of a Manufacturing Defect	2 Year
Limited Warranty for Sealed Refrigeration System*; Parts and Labor	3rd to 6th Year
Limited Warranty for Sealed Refrigeration System*; Parts Only	7th to 12th Year

*Height adjustable + 1/2" (13 mm) with legs fully extended
 **Sealed refrigeration system includes compressor, evaporator, condenser, dryer / strainer and connection tubing

UNDER-COUNTER REFRIGERATION PLANNING INFORMATION

MODEL OPTIONS

The under-counter refrigeration series includes a glass door wine reserve (available with a right or left door swing) and a double refrigerator drawer unit. All units install fully flush to be seamlessly integrated into 24" depth cabinetry. Each unit is available custom-panel ready or in stainless steel with a Masterpiece® or Professional Handle to complement the entire collection of Thermador appliances.

INSTALLATION CONSIDERATIONS

LOCATION

The appliance should be installed in a dry, ventilated room. It may not be installed outdoors. The ambient temperature of the room should stay between 55°F (13°C) and 110°F (43°C).

The appliance should not be exposed to excessive heat. If installation next to a heat source, such as an oven, radiator, etc. is unavoidable, use a suitable insulating plate or observe the following minimum distances from the heat source:

- 1 1/4" (30 mm) from an electric cooking appliance,
- 11 13/16" (300 mm) from an oil or solid-fuel cooking appliance.

Ensure that the exterior air vent is not blocked by cabinetry or other elements.

ELECTRICAL SPECIFICATIONS

The appliance comes with a 3-wire power supply cord, UL-listed in the USA and requires a 3-wire receptacle that is fitted with a 15- or 20-Amp fuse. The cord length is 50" (1270 mm).

GROUNDING INSTRUCTION

This appliance must be grounded. In the event of a malfunction or breakdown, grounding will reduce the risk of electric shock by providing a path of least resistance for the electric current.

ADDITIONAL GROUNDING PROCEDURE

Some local regulations may require a separate ground. In such cases, the required accessory ground wire, clamp and screw must be purchased separately. Never ground the appliance to plastic plumbing lines, gas lines or water pipes.

A 4-conductor cord shall be used when the appliance is installed in an area where local codes do not permit grounding through the neutral. Power supply cord must be replaced by a licensed electrician only.

WARNING

Improper connection of the equipment grounding conductor may result in electric shock. Have the appliance checked by a qualified electrician or service technician if you are in doubt as to whether the appliance has been properly grounded.

ELECTRICAL LOCATION

For standard 24" (610 mm) depth cutouts, the receptacle should be recessed in the rear wall or located to either side of the cutout. For deeper—25" (635 mm) or greater—cutouts, the receptacle may be located on the rear wall, however, the recommended location for any depth cutout is to the right or left side of the cutout. If receptacle is placed outside of the cutout, a 2 1/2" (63 mm) diameter access hole is recommended to accommodate the 3-wire power supply cord.

UNDER-COUNTER REFRIGERATION INSTALLATION

GLASS DOOR WINE RESERVE PRODUCT DIMENSIONS

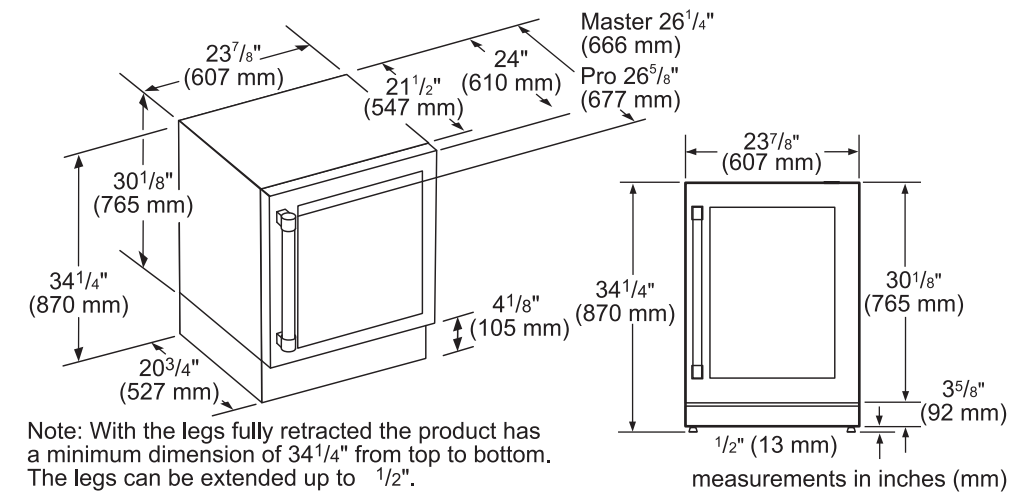

GLASS DOOR WINE RESERVE CUTOUT DIMENSIONS

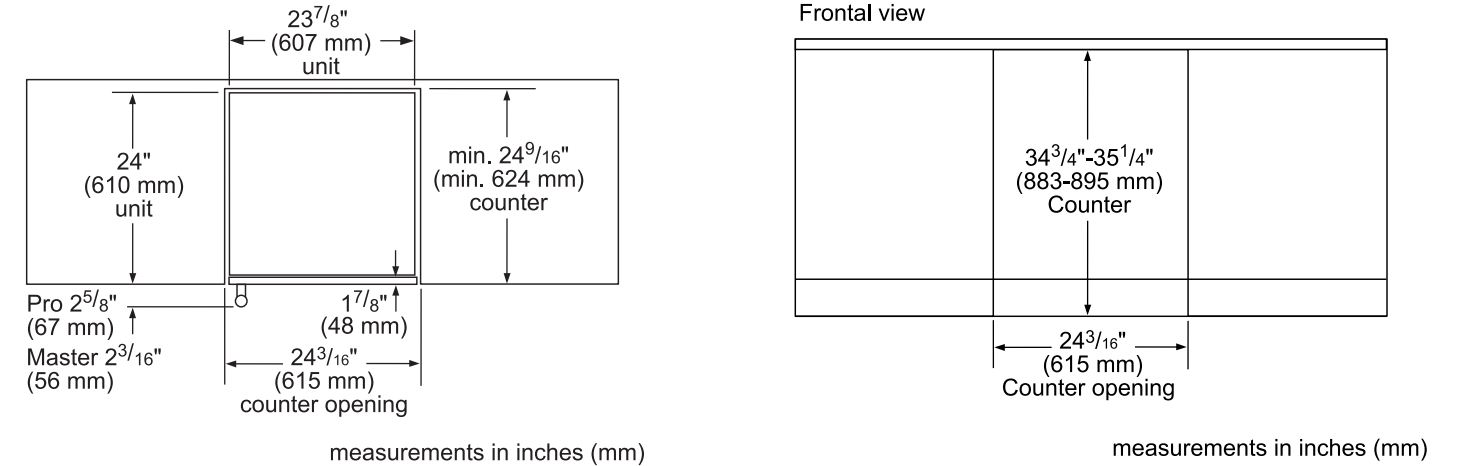

GLASS DOOR WINE RESERVE CUTOUT DIMENSIONS & ELECTRICAL LOCATION

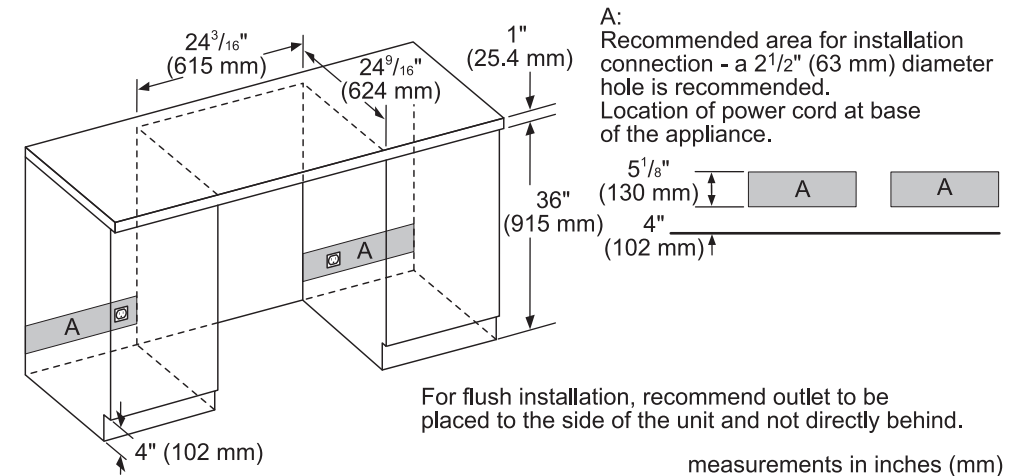

UNDER-COUNTER REFRIGERATION INSTALLATION

GLASS DOOR WINE RESERVE CUTOUT & DOOR SWING DIMENSIONS

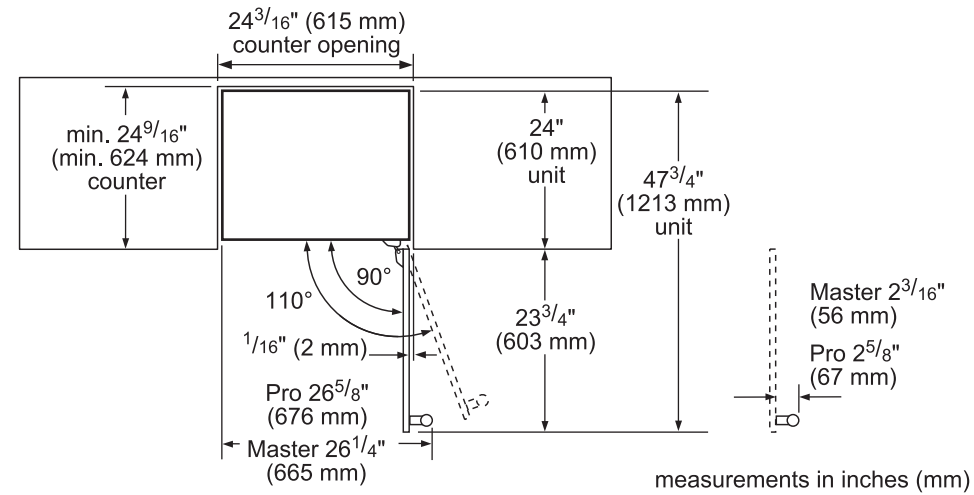
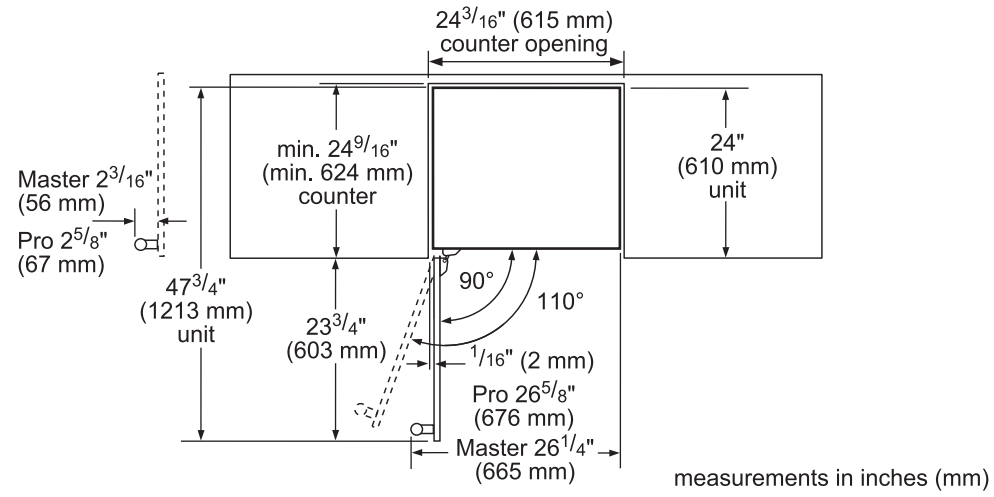

GLASS DOOR WINE RESERVE SIDE-BY-SIDE INSTALLATION

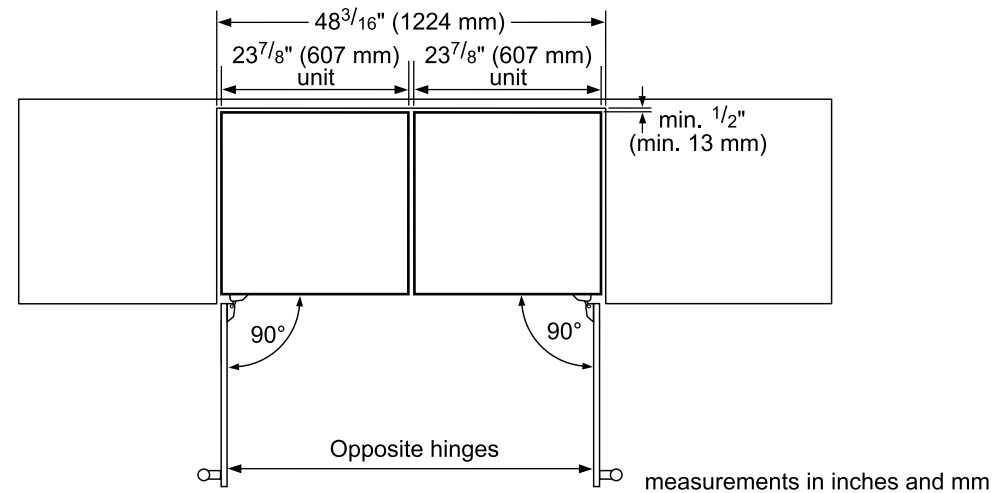

UNDER-COUNTER REFRIGERATION INSTALLATION

GLASS DOOR WINE RESERVE CUSTOM PANEL DIMENSIONS

Overlay Panel - Rear View

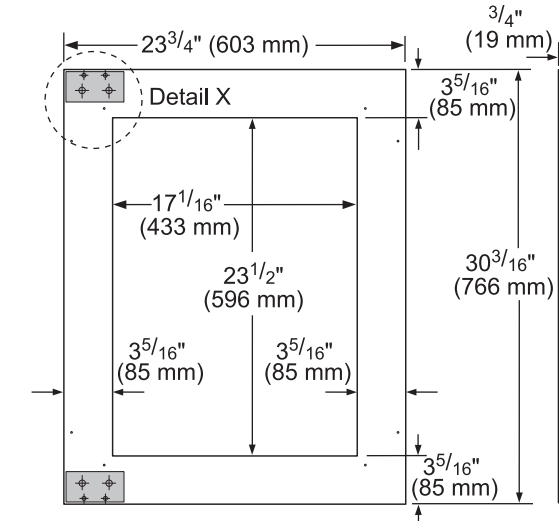

- Notes:
1. The thickness of the overlay panel must be $\frac{3}{4}$ " (19 mm).
 2. Overlay panel must not weigh more than 10 lbs (4.54 kg).
 3. Overlay panels weighing more than recommended may cause damage to your appliance.
 4. It is recommended to have the help of a second person to install the panel.
 5. Use the recommended tools in the installation manual to facilitate the installation of the panel. Fail to use the adequate tooling or the help of a second person may result in damage to the panel and/or the appliance.
 6. The following graphic shows a custom panel for a door with the hinges installed on the right-hand side. If your wine cellar has hinges installed on the left-hand side, rotate the custom panel 180° so the hinge making will be on the left.

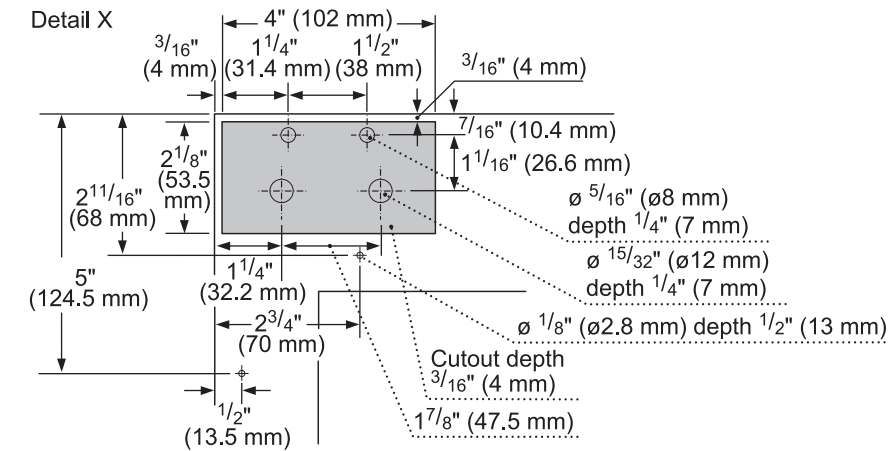

Measurements in inches (mm)

UNDER-COUNTER REFRIGERATION INSTALLATION

DOUBLE DRAWER REFRIGERATOR PRODUCT DIMENSIONS

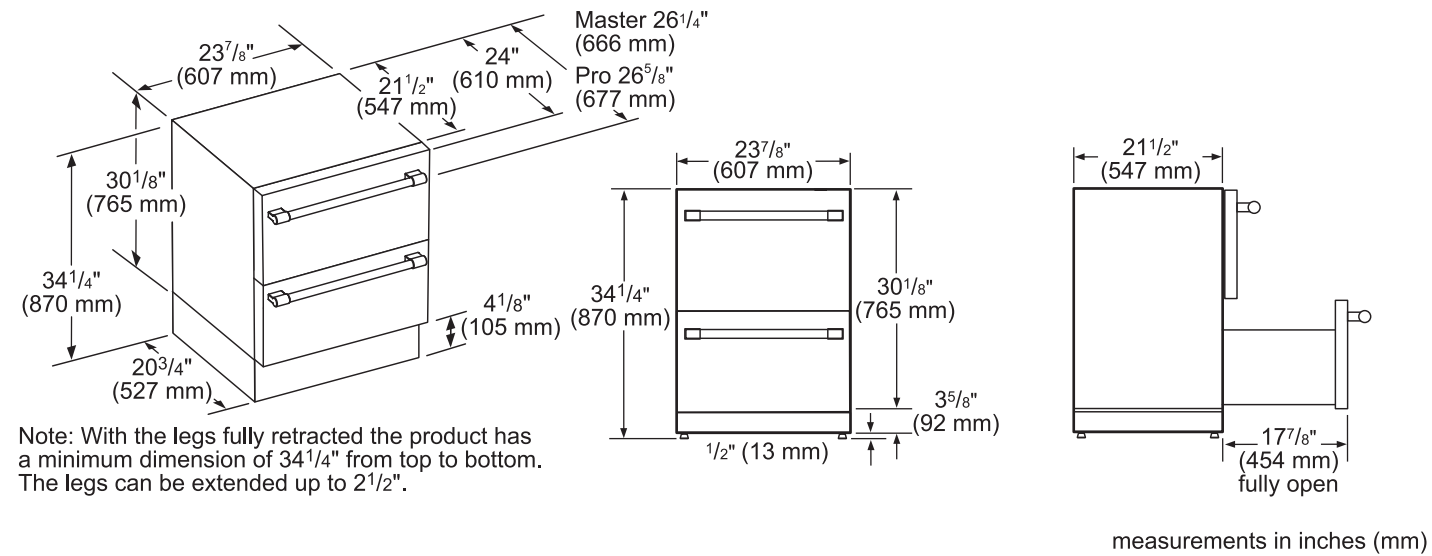

DOUBLE DRAWER REFRIGERATOR CUTOUT DIMENSIONS

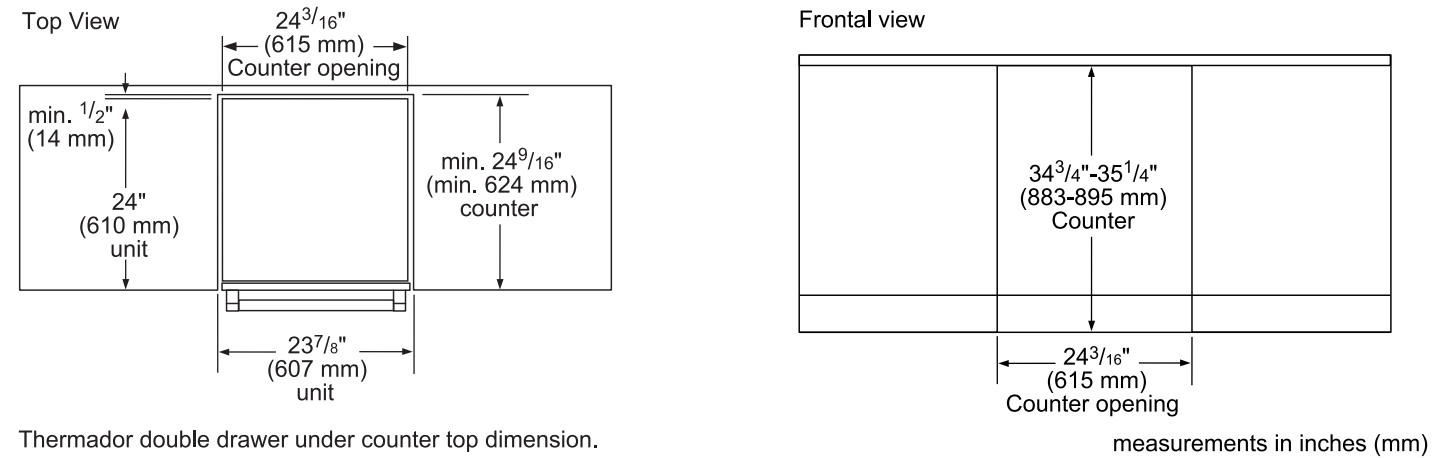

Thermador double drawer under counter top dimension. (Unit door flushed with the cutout)

DOUBLE DRAWER REFRIGERATOR CLEARANCE DIMENSIONS

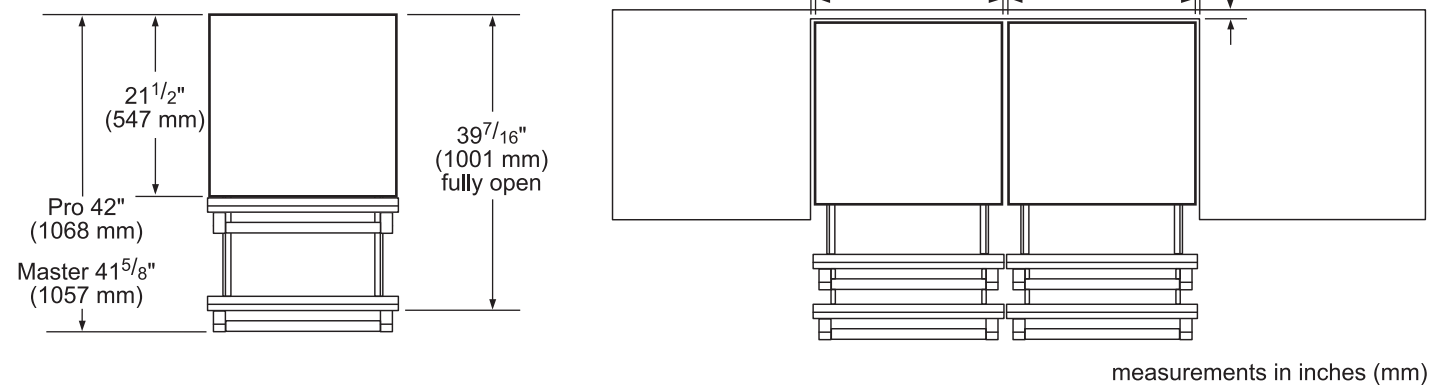

UNDER-COUNTER REFRIGERATION INSTALLATION

DOUBLE DRAWER REFRIGERATOR CUTOUT DIMENSIONS & ELECTRICAL LOCATION

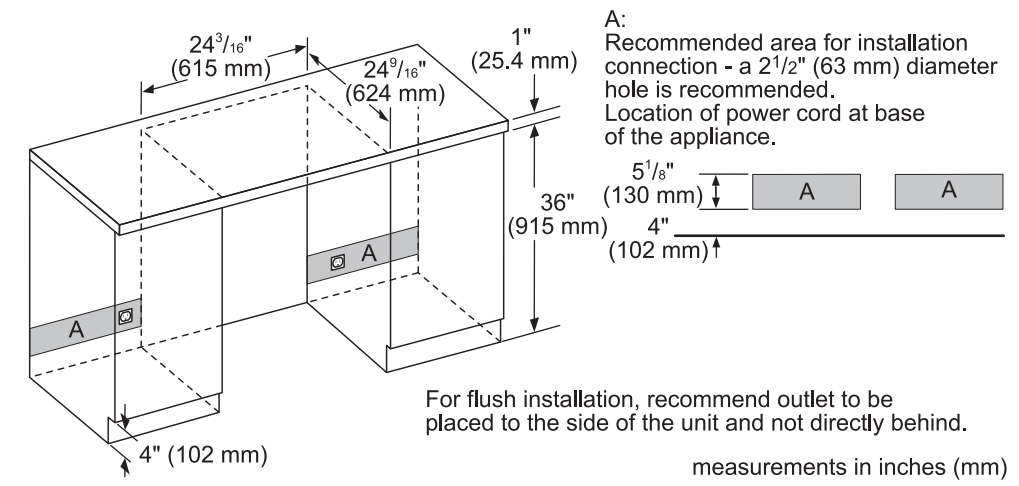

DOUBLE DRAWER REFRIGERATOR CUSTOM PANEL DIMENSIONS

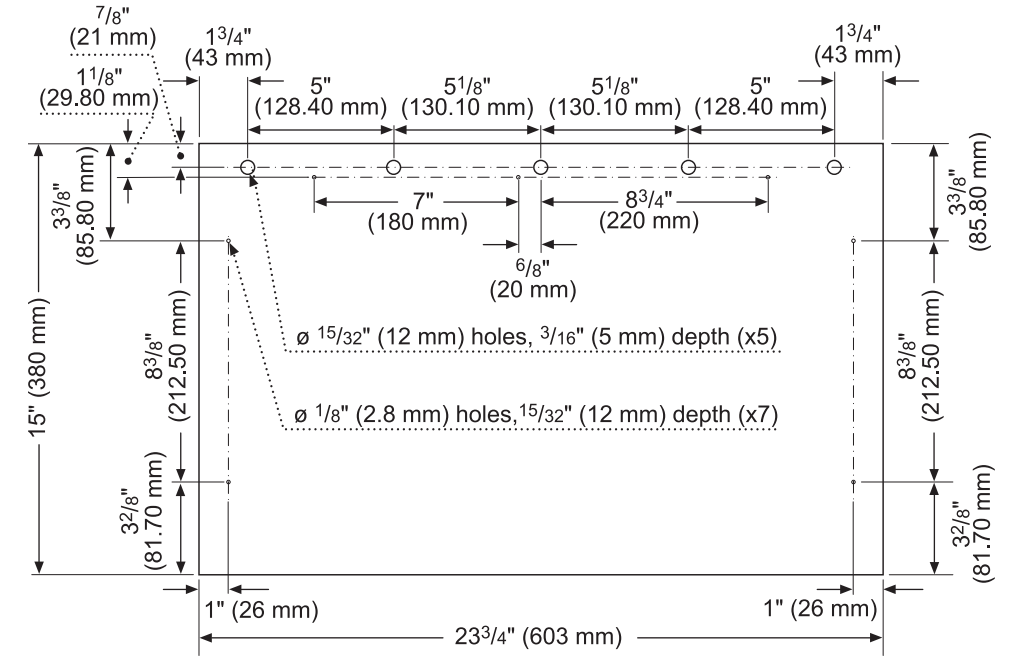

- Notes:
- The $\varnothing 15/32$ (12 mm) holes are only needed in the top panel. Bottom panel does not need these holes.
 - The thickness of the overlay panel must be $3/4$ " (19 mm).
 - Overlay panel must not weigh more than 4.54 kg (10 lb).
 - Overlay panel weighing more than recommended may cause damage to the appliance.
 - It is recommended to have the help of a second person to install the panel.
 - Use the recommended tools in the installation manual to facilitate the installation of the panel. Failure to use the recommended tools or the help of a second person may result in damage to the panel and/or the appliance.

measurements in inches (mm)



Thermador 

DISHWASHER COLLECTION

Exceptional entertainers tell a unique culinary story with every meal—and there is one thread that runs through the beginning to the end.

Engineered to handle your dishes before, during and after a dinner party, Thermador Dishwashers are equipped with performance, capacity, speed and flexibility—not to mention sheer beauty, with an option for flush, custom panels and a choice between two sleek handle options.

Star Sapphire® the Star of the Kitchen MOVES AT LIGHT SPEED

★ ENTERTAINER'S DRAWER (NEW)

Exclusive to Thermador, the Entertainer's Drawer provides two inches of clearance for hard-to-place items that are usually hand-washed, or that take up valuable space on the top rack. Easily load a variety of tools in your arsenal—from mini spatulas to large knives.

★ STAR GLOW (NEW)

Illuminate the inside of the dishwasher to set the mood that matches the occasion. Star Glow allows you to customize lighting and choose from three vivid shades of sapphire blue or three radiant shades of white.

★ STAR SPEED®

The fastest in the industry at an unprecedented 20 minutes, the Star Speed hot water cycle ensures you'll always be ready for another round.*

★ LARGEST WINE GLASS CAPACITY

No need to clean your glassware in two cycles; wash them all at once so you can get back to your guests. The Star Sapphire Dishwasher offers the largest wine glass capacity available in the industry, can hold up to 24 wine glasses on the top and bottom rack, and also features a wine glass caddy to provide the ultimate peace of mind for your most precious glassware.**

★ ULTRA SMOOTH GLIDE RACKS (NEW)

Load and unload dishes with ease. Gentle Smooth Glide Racks minimize friction, noise, and feel smooth so you can discreetly fill the dishwasher while entertaining.

★ TIME REMAINING POWERBEAM®

Always know exactly how much time is left in a cycle with the unique Time Remaining PowerBeam—a vibrant readout projected onto the floor below the dishwasher.

★ PREMIUM CONTROL PANEL

Easy on the eyes and smooth to the touch, the premium touch-screen control panel is a sleek addition to the Star Sapphire Dishwasher. Intuitive controls allow you to quickly find the setting you need—and never miss a beat while entertaining.

*Based on wash cycle times contained in major luxury brands' manuals. Luxury brands defined as TraQline Price Bucket of greater than \$1,301 August 2017.

**Based on loading recommendations in major luxury brands' manuals. Luxury brands defined as TraQline Price Bucket of greater than \$1,301 August 2017.



Dishwasher FEATURE HIGHLIGHTS

EMERALD® MODELS FEATURE:

BLUE POWERBEAM® STATUS INDICATOR

The PowerBeam operating indicator lets you know when the unit is running with our signature blue light.

FINE SILVERWARE CARAFE

The aluminum construction of our Fine Silverware Carafe accessory (sold separately) protects valuable sterling silver flatware from damaging oxidation so it can be safely washed in the dishwasher.

TOPAZ® MODELS ADD THESE FEATURES:

CHEF'S TOOL DRAWER®

A cook's work is never done, but an upgraded tool drawer makes cleanup much easier. With a design that accommodates oversized and wide-handled tools, loading and unloading become seamless and cleaning more thorough.

EXTRA-TALL-ITEM SPRINKLER

Sprinkler delivers powerful spray stream to ensure large items can be cleaned—without removing the Chef's Tool Drawer. Cleans items up to 22 inches tall, such as platters and baking sheets, eliminating the need to hand wash.

CRYSTAL PROTECT® SYSTEM

Utilizes a built-in water softener to neutralize water hardness for perfectly clear crystal, free of water spots.

SAPPHIRE® MODELS ADD THESE FEATURES:

★ SAPPHIRE GLOW®

Bring the results of a perfect wash to light with sparkling blue light that illuminates when the dishwasher is opened, giving just-cleaned stemware and dishes a luxurious glow.

ADJUSTABLE CHEF'S TOOL DRAWER®

Providing serious loading capacity for small and large utensils, this flexible 3rd Rack delivers not only added loading capacity, but adjustability to accommodate larger or smaller items, wider ends, and utensil handles.

FLEXIBLE FOLDING TINES

Another feature that makes Thermador® Dishwashers the most versatile on the market. Flexible Folding Tines fold down to accommodate larger pots, pans, and dishes providing the capacity to hold items twice as wide as previous models, and significantly wider than competitors.

★ THERMADOR® EXCLUSIVE

Design Versatility ONLY FROM THERMADOR®

The ingenious Dishwasher Collection from Thermador lets you take kitchen design to a higher level. The possibilities are endless with four distinct series to choose from, each with five unique design options to perfectly complement your kitchen design.



Flat Stainless Steel Panel with Professional Handle



Flat Stainless Steel Panel with Masterpiece® Handle



Chiseled Stainless Steel Panel with Professional Handle*



Chiseled Stainless Steel Panel with Masterpiece® Handle*



Custom Panel to Match Your Cabinetry

FULLY FLUSH CUSTOM PANEL DISHWASHERS MAKE YOUR DISHWASHER DISAPPEAR

Match your kitchen's custom cabinetry to our dishwasher for complete integration. Thermador custom panel dishwashers are the only dishwashers available that install fully flush for a seamless, integrated look. Everything needed to install your custom panel comes in the box.

PROTECTING YOUR FINE WOOD CABINETS

Thermador dishwashers feature a unique condensation drying system that eliminates the risk of steam damage over time to custom panel wood cabinetry and countertops. The closed system heats dishes with hot water from the final rinse.

*Available as an accessory



DWHD440MFP EMERALD® 4-PROGRAM DISHWASHER PROFESSIONAL SERIES HANDLE

Thermador®



Also Available In:
DWHD440MFM - Flat Stainless Steel Panel with Masterpiece® Series Handle
DWHD440MPR - Custom Panel

FEATURES & BENEFITS

- Sens-A-Wash® measures water cleanliness and adjusts wash cycle
- Three stage advanced filtration recirculates water for sparkling results
- Accommodates 15 place settings for your dinner parties
- Extra Dry Option ensures perfectly dry dishes and sanitizes 99.9% of bacteria
- Impressively Quiet®—48 dBA for peaceful kitchen experience

ACCESSORIES (OPTIONAL)

Dishwasher Supply and Drainage Hose Extension 76 3/4"	SGZ1010UC
Dishwasher Accessory Kit	SMZ5000
Fine Silverware Carafe	SMZ5002UC



Accessory Kit includes Extra-Tall-Item Sprinkler, Vase / Bottle Holder, 3 Plastic Item Clips and Small Item Basket

Fine Silverware Carafe

GENERAL PROPERTIES

Number Of Wash Cycles	4
Number Of Options	4
dBA	48
Third Rack	N/A
Rack Adjustability	Rackmatic 3-Stage
Tub Material	Stainless Steel
Control Type	Buttons
Concealed Heating Element	Yes
Leak Protection System	24/7 AquaStop® Plus
Water Softener	No
Five-Level Wash	Yes
Childlock	No

EFFICIENCY

Water Usage Per Cycle (g)	2.9 g
Energy Efficiency Class	Tier 1
ENERGY STAR® Qualified	Yes
Total Annual Energy Consumption (kWh)	269 kWh
Total Annual Water Consumption (g)	624 g

CAPACITY

Number Of Place Settings	15
--------------------------	----

TECHNICAL DETAILS

Watts (W)	1,440 W
Current (A)	12 A
Volts (V)	120 V
Frequency (Hz)	60 Hz
Power Cord Length (in)	43 1/2"
Minimum Water Pressure (lb/sin)	14
Max. Temperature for Water Intake	140° F
Length Outlet Hose (in)	67"

DIMENSIONS & WEIGHT

Overall Appliance Dimensions (HxWxD) (in)	33 7/8" x 23 9/16" x 23 3/4"
Required Cutout Size (HxWxD) (in)	33 7/8" x 23 5/8" x 24"
Adjustable Feet	Yes
Net Weight (lbs)	86 lbs

WARRANTY

Limited Warranty, Entire Appliance, Parts and Labor	2 Year
Limited Warranty for Microprocessor or Printed Circuit Board; Parts Only	3rd to 5th Year
Limited Warranty for Racks (Does Not Include Rack Components); Parts Only	3rd to 5th Year
Limited Warranty for Rust-through On Inner Tub Liner; Parts Only	Lifetime

*minimum height requirement

DWHD440MFM

EMERALD® 4-PROGRAM DISHWASHER

MASTERPIECE® SERIES HANDLE



Also Available In:
 DWHD440MFP - Flat Stainless Steel Panel
 with Professional Series Handle
 DWHD440MPR - Custom Panel

FEATURES & BENEFITS

- Sens-A-Wash® measures water cleanliness and adjusts wash cycle
- Three stage advanced filtration recirculates water for sparkling results
- Accommodates 15 plate settings for your dinner parties
- Extra Dry Option ensures perfectly dry dishes and sanitizes 99.9% of bacteria
- Impressively Quiet®-48 dBA for peaceful kitchen experience

ACCESSORIES (OPTIONAL)

Dishwasher Supply and Drainage Hose Extension 76 3/4"	SGZ1010UC
Dishwasher Accessory Kit	SMZ5000
Fine Silverware Carafe	SMZ5002UC



Accessory Kit includes Extra-Tall-Item Sprinkler, Vase / Bottle Holder, 3 Plastic Item Clips and Small Item Basket



Fine Silverware Carafe

GENERAL PROPERTIES

Number Of Wash Cycles	4
Number Of Options	4
dBA	48
Third Rack	N/A
Rack Adjustability	Rackmatic 3-Stage
Tub Material	Stainless Steel
Control Type	Buttons
Concealed Heating Element	Yes
Leak Protection System	24/7 AquaStop® Plus
Water Softener	No
Five-Level Wash	Yes
Childlock	No

EFFICIENCY

Water Usage Per Cycle (g)	2.9 g
Energy Efficiency Class	Tier 1
ENERGY STAR® Qualified	Yes
Total Annual Energy Consumption (kWh)	269 kWh
Total Annual Water Consumption (g)	624 g

CAPACITY

Number Of Place Settings	15
--------------------------	----

TECHNICAL DETAILS

Watts (W)	1,440 W
Current (A)	12 A
Volts (V)	120 V
Frequency (Hz)	60 Hz
Power Cord Length (in)	43 1/2"
Minimum Water Pressure (lb/sin)	14
Max. Temperature for Water Intake	140° F
Length Outlet Hose (in)	67"

DIMENSIONS & WEIGHT

Overall Appliance Dimensions (HxWxD) (in)	33 7/8" x 23 9/16" x 23 3/4"
Required Cutout Size (H*xWxD) (in)	33 7/8" x 23 5/8" x 24"
Adjustable Feet	Yes
Net Weight (lbs)	85 lbs

WARRANTY

Limited Warranty, Entire Appliance, Parts and Labor	2 Year
Limited Warranty for Microprocessor or Printed Circuit Board; Parts Only	3rd to 5th Year
Limited Warranty for Racks (Does Not Include Rack Components); Parts Only	3rd to 5th Year
Limited Warranty for Rust-through On Inner Tub Liner; Parts Only	Lifetime

*minimum height requirement

DWHD440MPR

EMERALD® 4-PROGRAM DISHWASHER

CUSTOM PANEL



Also Available In:
 DWHD440MFP - Flat Stainless Steel Panel
 with Professional Series Handle
 DWHD440MFM - Flat Stainless Steel Panel
 with Masterpiece® Series Handle

FEATURES & BENEFITS

- Sens-A-Wash® measures water cleanliness and adjusts wash cycle
- Three stage advanced filtration recirculates water for sparkling results
- Accommodates 15 plate settings for your dinner parties
- Extra Dry Option ensures perfectly dry dishes and sanitizes 99.9% of bacteria
- Impressively Quiet®-48 dBA for peaceful kitchen experience

ACCESSORIES (OPTIONAL)

Dishwasher Supply and Drainage Hose Extension 76 3/4"	SGZ1010UC
Dishwasher Accessory Kit	SMZ5000
Fine Silverware Carafe	SMZ5002UC
24" Stainless Steel Chiseled Door with Masterpiece Handle	DWHDZJCMD
24" Stainless Steel Chiseled Door with Professional Handle	DWHDZJCPD

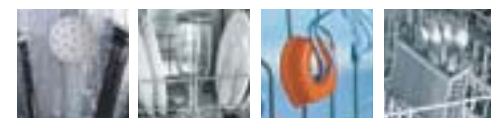

Accessory Kit includes Extra-Tall-Item Sprinkler, Vase / Bottle Holder, 3 Plastic Item Clips and Small Item Basket



Fine Silverware Carafe

GENERAL PROPERTIES

Number Of Wash Cycles	4
Number Of Options	4
dBA	48
Third Rack	N/A
Rack Adjustability	Rackmatic 3-Stage
Tub Material	Stainless Steel
Control Type	Buttons
Concealed Heating Element	Yes
Leak Protection System	24/7 AquaStop® Plus
Water Softener	No
Five-Level Wash	Yes
Childlock	No

EFFICIENCY

Water Usage Per Cycle (g)	2.9 g
Energy Efficiency Class	Tier 1
ENERGY STAR® Qualified	Yes
Total Annual Energy Consumption (kWh)	269 kWh
Total Annual Water Consumption (g)	624 g

CAPACITY

Number Of Place Settings	15
--------------------------	----

TECHNICAL DETAILS

Watts (W)	1,440 W
Current (A)	12 A
Volts (V)	120 V
Frequency (Hz)	60 Hz
Power Cord Length (in)	43 1/2"
Minimum Water Pressure (lb/sin)	14
Max. Temperature for Water Intake	140° F
Length Outlet Hose (in)	67"

DIMENSIONS & WEIGHT

Overall Appliance Dimensions (HxWxD) (in)	33 7/8" x 23 9/16" x 23 1/16"
Required Cutout Size (H*xWxD) (in)	33 7/8" x 23 5/8" x 24"
Adjustable Feet	Yes
Net Weight (lbs)	83 lbs

WARRANTY

Limited Warranty, Entire Appliance, Parts and Labor	2 Year
Limited Warranty for Microprocessor or Printed Circuit Board; Parts Only	3rd to 5th Year
Limited Warranty for Racks (Does Not Include Rack Components); Parts Only	3rd to 5th Year
Limited Warranty for Rust-through On Inner Tub Liner; Parts Only	Lifetime

*minimum height requirement

DWHD640JFP
TOPAZ® 6-PROGRAM DISHWASHER
 PROFESSIONAL SERIES HANDLE



Also Available In:
 DWHD640JFM - Flat Stainless Steel Panel
 with Masterpiece® Series Handle
 DWHD640JPR - Custom Panel

FEATURES & BENEFITS

- ★ - Blue PowerBeam® operating indicator lets you know when dishwasher is running
- Crystal Protect® system adjusts the water softness during the cycle for perfectly clear crystal, free of water spots
- PowerBoost® option increases temperature and pressure in the lower rack for the ultimate performance in heavy-duty cleaning
- Sens-A-Wash® measures water cleanliness and adjusts wash cycle
- Extra Dry Option ensures perfectly dry dishes and sanitizes 99.9% of bacteria

ACCESSORIES (OPTIONAL)

Dishwasher Softener Salt (4.4 lbs)	SGZ9091UC
Dishwasher Supply and Drainage Hose Extension 76 3/4"	SGZ1010UC
Dishwasher Accessory Kit	SMZ5000
Fine Silverware Carafe	SMZ5002UC



Accessory Kit includes Extra-Tall-Item Sprinkler, Vase / Bottle Holder, 3 Plastic Item Clips and Small Item Basket



Fine Silverware Carafe

GENERAL PROPERTIES

Number Of Wash Cycles	6
Number Of Options	4
dBA	44
Third Rack	Chef's Tool Drawer®
Rack Adjustability	Rackmatic 3-Stage
Tub Material	Stainless Steel
Control Type	Buttons
Concealed Heating Element	Yes
Leak Protection System	24/7 AquaStop® Plus
Water Softener	Yes
Five-Level Wash	Yes
Childlock	No

EFFICIENCY

Water Usage Per Cycle (g)	2.9 g
Energy Efficiency Class	Tier 1
ENERGY STAR® Qualified	Yes
Total Annual Energy Consumption (kWh)	269 kWh
Total Annual Water Consumption (g)	623.5 g

CAPACITY

Number Of Place Settings	14
--------------------------	----

TECHNICAL DETAILS

Watts (W)	1,440 W
Current (A)	12 A
Volts (V)	120 V
Frequency (Hz)	60 Hz
Power Cord Length (in)	47 1/4"
Minimum Water Pressure (lb/sin)	7
Max. Temperature for Water Intake	140° F
Length Inlet Hose (in)	55 1/8"
Length Outlet Hose (in)	55 1/8"

DIMENSIONS & WEIGHT

Overall Appliance Dimensions (HxWxD) (in)	34 1/16" x 23 9/16" x 22 7/16"
Required Cutout Size (H*xWxD) (in)	34 1/16" x 24" x 24"
Adjustable Feet	Yes
Net Weight (lbs)	102 lbs

ACCESSORIES (INCLUDED)

Baking-Sheet Spray Head Grey

WARRANTY

Limited Warranty, Entire Appliance, Parts and Labor	2 Year
Limited Warranty for Microprocessor or Printed Circuit Board; Parts Only	3rd to 5th Year
Limited Warranty for Racks (Does Not Include Rack Components); Parts Only	3rd to 5th Year
Limited Warranty for Rust-through On Inner Tub Liner; Parts Only	Lifetime

*minimum height requirement

DWHD640JFM
TOPAZ® 6-PROGRAM DISHWASHER
 MASTERPIECE® SERIES HANDLE



Also Available In:
 DWHD640JFP - Flat Stainless Steel Panel
 with Professional Series Handle
 DWHD640JPR - Custom Panel

FEATURES & BENEFITS

- ★ - Blue PowerBeam® operating indicator lets you know when dishwasher is running
- Crystal Protect® system adjusts the water softness during the cycle for perfectly clear crystal, free of water spots
- PowerBoost® option increases temperature and pressure in the lower rack for the ultimate performance in heavy-duty cleaning
- Sens-A-Wash® measures water cleanliness and adjusts wash cycle
- Extra Dry Option ensures perfectly dry dishes and sanitizes 99.9% of bacteria

ACCESSORIES (OPTIONAL)

Dishwasher Softener Salt (4.4 lbs)	SGZ9091UC
Dishwasher Supply and Drainage Hose Extension 76 3/4"	SGZ1010UC
Dishwasher Accessory Kit	SMZ5000
Fine Silverware Carafe	SMZ5002UC

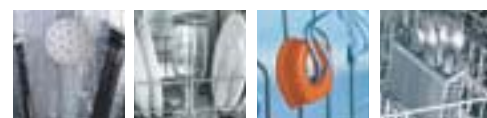

Accessory Kit includes Extra-Tall-Item Sprinkler, Vase / Bottle Holder, 3 Plastic Item Clips and Small Item Basket



Fine Silverware Carafe

GENERAL PROPERTIES

Number Of Wash Cycles	6
Number Of Options	4
dBA	44
Third Rack	Chef's Tool Drawer®
Rack Adjustability	Rackmatic 3-Stage
Tub Material	Stainless Steel
Control Type	Buttons
Concealed Heating Element	Yes
Leak Protection System	24/7 AquaStop® Plus
Water Softener	Yes
Five-Level Wash	Yes
Childlock	No

EFFICIENCY

Water Usage Per Cycle (g)	2.9 g
Energy Efficiency Class	Tier 1
ENERGY STAR® Qualified	Yes
Total Annual Energy Consumption (kWh)	269 kWh
Total Annual Water Consumption (g)	623.5 g

CAPACITY

Number Of Place Settings	14
--------------------------	----

TECHNICAL DETAILS

Watts (W)	1,440 W
Current (A)	12 A
Volts (V)	120 V
Frequency (Hz)	60 Hz
Power Cord Length (in)	47 1/4"
Minimum Water Pressure (lb/sin)	7
Max. Temperature for Water Intake	140° F
Length Inlet Hose (in)	55 1/8"
Length Outlet Hose (in)	55 1/8"

DIMENSIONS & WEIGHT

Overall Appliance Dimensions (HxWxD) (in)	34 1/16" x 23 9/16" x 22 7/16"
Required Cutout Size (H*xWxD) (in)	34 1/16" x 24" x 24"
Adjustable Feet	Yes
Net Weight (lbs)	101 lbs

ACCESSORIES (INCLUDED)

Baking-Sheet Spray Head Grey

WARRANTY

Limited Warranty, Entire Appliance, Parts and Labor	2 Year
Limited Warranty for Microprocessor or Printed Circuit Board; Parts Only	3rd to 5th Year
Limited Warranty for Racks (Does Not Include Rack Components); Parts Only	3rd to 5th Year
Limited Warranty for Rust-through On Inner Tub Liner; Parts Only	Lifetime

*minimum height requirement

DWHD640JPR

TOPAZ® 6-PROGRAM DISHWASHER

CUSTOM PANEL



Also Available In:
 DWHD640JFP - Flat Stainless Steel Panel with Professional Series Handle
 DWHD640JFM - Flat Stainless Steel Panel with Masterpiece® Series Handle

FEATURES & BENEFITS

- ★ - Blue PowerBeam® operating indicator lets you know when dishwasher is running
- Crystal Protect® system adjusts the water softness during the cycle for perfectly clear crystal, free of water spots
- PowerBoost® option increases temperature and pressure in the lower rack for the ultimate performance in heavy-duty cleaning
- Sens-A-Wash® measures water cleanliness and adjusts wash cycle
- Extra Dry Option ensures perfectly dry dishes and sanitizes 99.9% of bacteria

ACCESSORIES (OPTIONAL)

Dishwasher Softener Salt (4.4 lbs)	SGZ9091UC
Dishwasher Supply and Drainage Hose Extension 76 3/4"	SGZ1010UC
Dishwasher Accessory Kit	SMZ5000
Fine Silverware Carafe	SMZ5002UC
24" Stainless Steel Chiseled Door with Masterpiece Handle	DWHDZJCMD
24" Stainless Steel Chiseled Door with Professional Handle	DWHDZJCPD



Accessory Kit includes Extra-Tall-Item Sprinkler, Vase / Bottle Holder, 3 Plastic Item Clips and Small Item Basket



Fine Silverware Carafe

Thermador ★

GENERAL PROPERTIES

Number Of Wash Cycles	6
Number Of Options	4
dBA	44
Third Rack	Chef's Tool Drawer®
Rack Adjustability	Rackmatic 3-Stage
Tub Material	Stainless Steel
Control Type	Buttons
Concealed Heating Element	Yes
Leak Protection System	24/7 AquaStop® Plus
Water Softener	Yes
Five-Level Wash	Yes
Childlock	No

EFFICIENCY

Water Usage Per Cycle (g)	2.9 g
Energy Efficiency Class	Tier 1
ENERGY STAR® Qualified	Yes
Total Annual Energy Consumption (kWh)	269 kWh
Total Annual Water Consumption (g)	623.5 g

CAPACITY

Number Of Place Settings	14
--------------------------	----

TECHNICAL DETAILS

Watts (W)	1,440 W
Current (A)	12 A
Volts (V)	120 V
Frequency (Hz)	60 Hz
Power Cord Length (in)	47 1/4"
Minimum Water Pressure (lb/sin)	7
Max. Temperature for Water Intake	140° F
Length Inlet Hose (in)	55 1/8"
Length Outlet Hose (in)	55 1/8"

DIMENSIONS & WEIGHT

Overall Appliance Dimensions (HxWxD) (in)	34 1/16" x 23 9/16" x 21 5/8"
Required Cutout Size (H*xWxD) (in)	34 1/16" x 24" x 24"
Adjustable Feet	Yes
Net Weight (lbs)	96 lbs

ACCESSORIES (INCLUDED)

Baking-Sheet Spray Head Grey

WARRANTY

Limited Warranty, Entire Appliance, Parts and Labor	2 Year
Limited Warranty for Microprocessor or Printed Circuit Board; Parts Only	3rd to 5th Year
Limited Warranty for Racks (Does Not Include Rack Components); Parts Only	3rd to 5th Year
Limited Warranty for Rust-through On Inner Tub Liner; Parts Only	Lifetime

*minimum height requirement

DWHD650JFP

SAPPHIRE® 6-PROGRAM DISHWASHER

PROFESSIONAL SERIES HANDLE



Also Available In:
 DWHD650JFM - Flat Stainless Steel Panel with Masterpiece® Series Handle
 DWHD650JPR - Custom Panel

FEATURES & BENEFITS

- ★ - Sapphire Glow® light illuminates with the sparkling blue light when the dishwasher is open
- ★ - Blue PowerBeam® operating indicator lets you know when dishwasher is running
- Adjustable Chef's Tool Drawer® delivers added loading capacity as well as flexibility to accommodate larger or smaller items, wider ends and utensil handles
- Flexible folding tines fold down to accommodate larger pots, pans, and dishes and add flexibility to hold items twice as wide as previous models and significantly wider than competitor
- Crystal Protect® system adjusts the water softness during the cycle for perfectly clear crystal, free of water spots

ACCESSORIES (OPTIONAL)

Dishwasher Softener Salt (4.4 lbs)	SGZ9091UC
Dishwasher Supply and Drainage Hose Extension 76 3/4"	SGZ1010UC
Dishwasher Accessory Kit	SMZ5000
Fine Silverware Carafe	SMZ5002UC

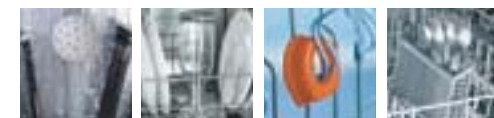

Accessory Kit includes Extra-Tall-Item Sprinkler, Vase / Bottle Holder, 3 Plastic Item Clips and Small Item Basket



Fine Silverware Carafe

Thermador ★

GENERAL PROPERTIES

Number Of Wash Cycles	6
Number Of Options	5
dBA	42
Third Rack	Adjustable Chef's Tool Drawer®
Rack Adjustability	Rackmatic 3-Stage
Tub Material	Stainless Steel
Control Type	Buttons
Concealed Heating Element	Yes
Leak Protection System	24/7 AquaStop® Plus
Water Softener	Yes
Five-Level Wash	Yes
Childlock	No

EFFICIENCY

Water Usage Per Cycle (g)	2.9 g
Energy Efficiency Class	Tier 1
ENERGY STAR® Qualified	Yes
Total Annual Energy Consumption (kWh)	260 kWh
Total Annual Water Consumption (g)	623.5 g

CAPACITY

Number Of Place Settings	14
--------------------------	----

TECHNICAL DETAILS

Watts (W)	1,440 W
Current (A)	12 A
Volts (V)	120 V
Frequency (Hz)	60 Hz
Power Cord Length (in)	47 1/4"
Minimum Water Pressure (lb/sin)	7
Max. Temperature for Water Intake	140° F
Length Inlet Hose (in)	55 1/8"
Length Outlet Hose (in)	55 1/8"

DIMENSIONS & WEIGHT

Overall Appliance Dimensions (HxWxD) (in)	34 1/16" x 23 9/16" x 22 7/16"
Required Cutout Size (H*xWxD) (in)	34 1/16" x 24" x 24"
Adjustable Feet	Yes
Net Weight (lbs)	104 lbs

ACCESSORIES (INCLUDED)

Baking-Sheet Spray Head Grey

WARRANTY

Limited Warranty, Entire Appliance, Parts and Labor	2 Year
Limited Warranty for Microprocessor or Printed Circuit Board; Parts Only	3rd to 5th Year
Limited Warranty for Racks (Does Not Include Rack Components); Parts Only	3rd to 5th Year
Limited Warranty for Rust-through On Inner Tub Liner; Parts Only	Lifetime

*minimum height requirement

DWHD650JFM

SAPPHIRE® 6-PROGRAM DISHWASHER

MASTERPIECE® SERIES HANDLE



Also Available In:
 DWHD650JFP - Flat Stainless Steel Panel with Professional Series Handle
 DWHD650JPR - Custom Panel

FEATURES & BENEFITS

- ★ - Sapphire Glow® light illuminates with the sparkling blue light when the dishwasher is open
- ★ - Blue PowerBeam® operating indicator lets you know when dishwasher is running
- Adjustable Chef's Tool Drawer® delivers added loading capacity as well as flexibility to accommodate larger or smaller items, wider ends and utensil handles
- Flexible folding tines fold down to accommodate larger pots, pans, and dishes and add flexibility to hold items twice as wide as previous models and significantly wider than competitor
- Crystal Protect® system adjusts the water softness during the cycle for perfectly clear crystal, free of water spots

ACCESSORIES (OPTIONAL)

Dishwasher Softener Salt (4.4 lbs)	SGZ9091UC
Dishwasher Supply and Drainage Hose Extension 76 3/4"	SGZ1010UC
Dishwasher Accessory Kit	SMZ5000
Fine Silverware Carafe	SMZ5002UC



Accessory Kit includes Extra-Tall-Item Sprinkler, Vase / Bottle Holder, 3 Plastic Item Clips and Small Item Basket



Fine Silverware Carafe

GENERAL PROPERTIES

Number Of Wash Cycles	6
Number Of Options	5
dBA	42
Third Rack	Adjustable Chef's Tool Drawer®
Rack Adjustability	Rackmatic 3-Stage
Tub Material	Stainless Steel
Control Type	Buttons
Concealed Heating Element	Yes
Leak Protection System	24/7 AquaStop® Plus
Water Softener	Yes
Five-Level Wash	Yes
Childlock	No

EFFICIENCY

Water Usage Per Cycle (g)	2.9 g
Energy Efficiency Class	Tier 1
ENERGY STAR® Qualified	Yes
Total Annual Energy Consumption (kWh)	260 kWh
Total Annual Water Consumption (g)	623.5 g

CAPACITY

Number Of Place Settings	14
--------------------------	----

TECHNICAL DETAILS

Watts (W)	1,440 W
Current (A)	12 A
Volts (V)	120 V
Frequency (Hz)	60 Hz
Power Cord Length (in)	47 1/4"
Minimum Water Pressure (lb/sin)	7
Max. Temperature for Water Intake	140° F
Length Inlet Hose (in)	55 1/8"
Length Outlet Hose (in)	55 1/8"

DIMENSIONS & WEIGHT

Overall Appliance Dimensions (HxWxD) (in)	34 1/16" x 23 9/16" x 22 7/16"
Required Cutout Size (H*xWxD) (in)	34 1/16" x 24" x 24"
Adjustable Feet	Yes
Net Weight (lbs)	103 lbs

ACCESSORIES (INCLUDED)

Baking-Sheet Spray Head Grey

WARRANTY

Limited Warranty, Entire Appliance, Parts and Labor	2 Year
Limited Warranty for Microprocessor or Printed Circuit Board; Parts Only	3rd to 5th Year
Limited Warranty for Racks (Does Not Include Rack Components); Parts Only	3rd to 5th Year
Limited Warranty for Rust-through On Inner Tub Liner; Parts Only	Lifetime

*minimum height requirement

DWHD650JPR

SAPPHIRE® 6-PROGRAM DISHWASHER

CUSTOM PANEL



Also Available In:
 DWHD650JFP - Flat Stainless Steel Panel with Professional Series Handle
 DWHD650JFM - Masterpiece® Series Handle

FEATURES & BENEFITS

- ★ - Sapphire Glow® light illuminates with the sparkling blue light when the dishwasher is open
- ★ - Blue PowerBeam® operating indicator lets you know when dishwasher is running
- Adjustable Chef's Tool Drawer® delivers added loading capacity as well as flexibility to accommodate larger or smaller items, wider ends and utensil handles
- Flexible folding tines fold down to accommodate larger pots, pans, and dishes and add flexibility to hold items twice as wide as previous models and significantly wider than competitor
- Crystal Protect® system adjusts the water softness during the cycle for perfectly clear crystal, free of water spots

ACCESSORIES (OPTIONAL)

Dishwasher Softener Salt (4.4 lbs)	SGZ9091UC
Dishwasher Supply and Drainage Hose Extension 76 3/4"	SGZ1010UC
Dishwasher Accessory Kit	SMZ5000
Fine Silverware Carafe	SMZ5002UC
24" Stainless Steel Chiseled Door with Masterpiece Handle	DWHDZJCMD
24" Stainless Steel Chiseled Door with Professional Handle	DWHDZJCPD

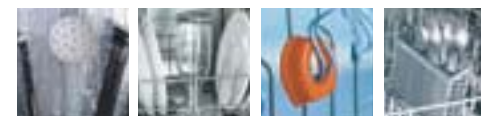

Accessory Kit includes Extra-Tall-Item Sprinkler, Vase / Bottle Holder, 3 Plastic Item Clips and Small Item Basket



Fine Silverware Carafe

GENERAL PROPERTIES

Number Of Wash Cycles	6
Number Of Options	5
dBA	42
Third Rack	Adjustable Chef's Tool Drawer®
Rack Adjustability	Rackmatic 3-Stage
Tub Material	Stainless Steel
Control Type	Buttons
Concealed Heating Element	Yes
Leak Protection System	24/7 AquaStop® Plus
Water Softener	Yes
Five-Level Wash	Yes
Childlock	No

EFFICIENCY

Water Usage Per Cycle (g)	2.9 g
Energy Efficiency Class	Tier 1
ENERGY STAR® Qualified	Yes
Total Annual Energy Consumption (kWh)	260 kWh
Total Annual Water Consumption (g)	623.5 g

CAPACITY

Number Of Place Settings	14
--------------------------	----

TECHNICAL DETAILS

Watts (W)	1,440 W
Current (A)	12 A
Volts (V)	120 V
Frequency (Hz)	60 Hz
Power Cord Length (in)	47 1/4"
Minimum Water Pressure (lb/sin)	7
Max. Temperature for Water Intake	140° F
Length Inlet Hose (in)	55 1/8"
Length Outlet Hose (in)	55 1/8"

DIMENSIONS & WEIGHT

Overall Appliance Dimensions (HxWxD) (in)	34 1/16" x 23 9/16" x 21 5/8"
Required Cutout Size (H*xWxD) (in)	34 1/16" x 24" x 24"
Adjustable Feet	Yes
Net Weight (lbs)	99 lbs

ACCESSORIES (INCLUDED)

Baking-Sheet Spray Head Grey

WARRANTY

Limited Warranty, Entire Appliance, Parts and Labor	2 Year
Limited Warranty for Microprocessor or Printed Circuit Board; Parts Only	3rd to 5th Year
Limited Warranty for Racks (Does Not Include Rack Components); Parts Only	3rd to 5th Year
Limited Warranty for Rust-through On Inner Tub Liner; Parts Only	Lifetime

*minimum height requirement

DWHD860RFP

STAR SAPPHIRE® 8-PROGRAM DISHWASHER

PROFESSIONAL SERIES HANDLE



Also Available In:
 (DWHD860RFM) - Flat Stainless Steel Panel
 with Masterpiece® Series Handle
 (DWHD860RPR) - Custom Panel

FEATURES & BENEFITS

- ★ - Entertainer's Drawer (3rd Rack) – provides the ultimate flexibility in cleaning your culinary kitchen tools
- ★ - Star Glow light illuminates your dishwasher with 3 levels of Sapphire Blue and introducing 3 levels of sparkling white light
 - Premium Control Panel: Capacitive Touch offering the ultimate in design to match your complete Thermador kitchen
- ★ - Wine Caddy Accessory – providing ultimate peace of mind when washing even your most delicate wine glasses
- ★ - Star Speed® is a full wash cycle in just 20 minutes – industry fastest hot water wash
 - Time remaining PowerBeam® shines the actual remaining time of the cycle on the floor

ACCESSORIES (OPTIONAL)

Dishwasher Softener Salt (4.4 lbs)	SGZ9091UC
Dishwasher Supply and Drainage Hose Extension 76 3/4"	SGZ1010
Dishwasher Accessory Kit	SMZ5000
Fine Silverware Carafe	SMZ5002UC



Accessory Kit includes Extra-Tall-Item Sprinkler, Vase / Bottle Holder, 3 Plastic Item Clips and Small Item Basket



Fine Silverware Carafe

GENERAL PROPERTIES

Number Of Wash Cycles	8
Number Of Options	6
dBA	44
Third Rack	Entertainer's Drawer
Rack Adjustability	Rackmatic 3-Stage
Tub Material	Stainless Steel
Control Type	Touch Controls
Concealed Heating Element	Yes
Leak Protection System	24/7 AquaStop® Plus
Water Softener	Yes
Five-Level Wash	Yes
Childlock	No

EFFICIENCY

Water Usage Per Cycle (g)	2.9 g
Energy Efficiency Class	Tier 1
ENERGY STAR® Qualified	Yes
Total Annual Energy Consumption (kWh)	269 kWh
Total Annual Water Consumption (g)	623.5 g

CAPACITY

Number Of Place Settings	15
--------------------------	----

TECHNICAL DETAILS

Watts (W)	1440 W
Current (A)	12 A
Volts (V)	120 V
Frequency (Hz)	60 Hz
Power Cord Length (in)	47 1/4"
Minimum Water Pressure (lb/sin)	7
Max. Temperature for Water Intake	140° F
Length Inlet Hose (in)	55 1/8"
Length Outlet Hose (in)	55 1/8"

DIMENSIONS & WEIGHT

Overall Appliance Dimensions (HxWxD) (in)	34 1/16" x 23 9/16" x 22 9/16"
Required Cutout Size (H*xWxD) (in)	34 1/16" x 24" x 24"
Adjustable Feet	Yes
Net Weight (lbs)	105 lbs

ACCESSORIES (INCLUDED)

Extra Tall Item Sprinkler, Wine Caddy

WARRANTY

Limited Warranty, Entire Appliance, Parts and Labor	2 Year
Limited Warranty for Microprocessor or Printed Circuit Board; Parts Only	3rd to 5th Year
Limited Warranty for Racks (Does Not Include Rack Components); Parts Only	3rd to 5th Year
Limited Warranty for Rust-through On Inner Tub Liner; Parts Only	Lifetime

*minimum height requirement

DWHD860RFM

STAR SAPPHIRE® 8-PROGRAM DISHWASHER

MASTERPIECE® SERIES HANDLE



Also Available In:
 (DWHD860RFP) - Flat Stainless Steel Panel
 with Professional Series Handle
 (DWHD860RPR) - Custom Panel

FEATURES & BENEFITS

- ★ - Entertainer's Drawer (3rd Rack) – provides the ultimate flexibility in cleaning your culinary kitchen tools
- ★ - Star Glow light illuminates your dishwasher with 3 levels of Sapphire Blue and introducing 3 levels of sparkling white light
 - Premium Control Panel: Capacitive Touch offering the ultimate in design to match your complete Thermador kitchen
- ★ - Wine Caddy Accessory – providing ultimate peace of mind when washing even your most delicate wine glasses
- ★ - Star Speed® is a full wash cycle in just 20 minutes – industry fastest hot water wash
 - Time remaining PowerBeam® shines the actual remaining time of the cycle on the floor

ACCESSORIES (OPTIONAL)

Dishwasher Softener Salt (4.4 lbs)	SGZ9091UC
Dishwasher Supply and Drainage Hose Extension 76 3/4"	SGZ1010
Dishwasher Accessory Kit	SMZ5000
Fine Silverware Carafe	SMZ5002UC



Accessory Kit includes Extra-Tall-Item Sprinkler, Vase / Bottle Holder, 3 Plastic Item Clips and Small Item Basket



Fine Silverware Carafe

GENERAL PROPERTIES

Number Of Wash Cycles	8
Number Of Options	6
dBA	44
Third Rack	Entertainer's Drawer
Rack Adjustability	Rackmatic 3-Stage
Tub Material	Stainless Steel
Control Type	Touch Controls
Concealed Heating Element	Yes
Leak Protection System	24/7 AquaStop® Plus
Water Softener	Yes
Five-Level Wash	Yes
Childlock	No

EFFICIENCY

Water Usage Per Cycle (g)	2.9 g
Energy Efficiency Class	Tier 1
ENERGY STAR® Qualified	Yes
Total Annual Energy Consumption (kWh)	269 kWh
Total Annual Water Consumption (g)	623.5 g

CAPACITY

Number Of Place Settings	15
--------------------------	----

TECHNICAL DETAILS

Watts (W)	1440 W
Current (A)	12 A
Volts (V)	120 V
Frequency (Hz)	60 Hz
Power Cord Length (in)	47 1/4"
Minimum Water Pressure (lb/sin)	7
Max. Temperature for Water Intake	140° F
Length Inlet Hose (in)	55 1/8"
Length Outlet Hose (in)	55 1/8"

DIMENSIONS & WEIGHT

Overall Appliance Dimensions (HxWxD) (in)	34 1/16" x 23 9/16" x 22 9/16"
Required Cutout Size (H*xWxD) (in)	34 1/16" x 24" x 24"
Adjustable Feet	Yes
Net Weight (lbs)	105 lbs

ACCESSORIES (INCLUDED)

Extra Tall Item Sprinkler, Wine Caddy

WARRANTY

Limited Warranty, Entire Appliance, Parts and Labor	2 Year
Limited Warranty for Microprocessor or Printed Circuit Board; Parts Only	3rd to 5th Year
Limited Warranty for Racks (Does Not Include Rack Components); Parts Only	3rd to 5th Year
Limited Warranty for Rust-through On Inner Tub Liner; Parts Only	Lifetime

*minimum height requirement

DWHD860RPR

STAR SAPPHIRE® 8-PROGRAM DISHWASHER

CUSTOM PANEL



DISHWASHERS

PLANNING INFORMATION



Also Available In:
 (DWHD860RFP) - Flat Stainless Steel Panel with Professional Series Handle
 (DWHD860RFM) - Flat Stainless Steel Panel with Masterpiece® Series Handle

FEATURES & BENEFITS

- ★ - Entertainer's Drawer (3rd Rack) – provides the ultimate flexibility in cleaning your culinary kitchen tools
- ★ - Star Glow light illuminates your dishwasher with 3 levels of Sapphire Blue and introducing 3 levels of sparkling white light
 - Premium Control Panel: Capacitive Touch offering the ultimate in design to match your complete Thermador kitchen
- ★ - Wine Caddy Accessory – providing ultimate peace of mind when washing even your most delicate wine glasses
- ★ - Star Speed® is a full wash cycle in just 20 minutes – industry fastest hot water wash
 - Time remaining PowerBeam® shines the actual remaining time of the cycle on the floor

ACCESSORIES (OPTIONAL)

Dishwasher Softener Salt (4.4 lbs)	SGZ9091UC
Dishwasher Supply and Drainage Hose Extension 76 3/4"	SGZ1010
Dishwasher Accessory Kit	SMZ5000
Fine Silverware Carafe	SMZ5002UC
24" Stainless Steel Chiseled Door with Masterpiece Handle	DWHDZJCMD
24" Stainless Steel Chiseled Door with Professional Handle	DWHDZJCPD

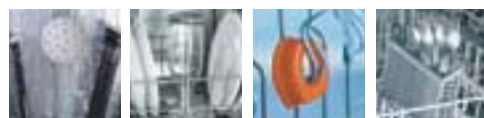

Accessory Kit includes Extra-Tall-Item Sprinkler, Vase / Bottle Holder, 3 Plastic Item Clips and Small Item Basket



Fine Silverware Carafe

GENERAL PROPERTIES

Number Of Wash Cycles	8
Number Of Options	6
dBA	44
Third Rack	Entertainer's Drawer
Rack Adjustability	Rackmatic 3-Stage
Tub Material	Stainless Steel
Control Type	Touch Controls
Concealed Heating Element	Yes
Leak Protection System	24/7 AquaStop® Plus
Water Softener	Yes
Five-Level Wash	Yes
Childlock	No

EFFICIENCY

Water Usage Per Cycle (g)	2.9 g
Energy Efficiency Class	Tier 1
ENERGY STAR® Qualified	Yes
Total Annual Energy Consumption (kWh)	269 kWh
Total Annual Water Consumption (g)	623.5 g

CAPACITY

Number Of Place Settings	15
--------------------------	----

TECHNICAL DETAILS

Watts (W)	1440 W
Current (A)	12 A
Volts (V)	120 V
Frequency (Hz)	60 Hz
Power Cord Length (in)	47 1/4"
Minimum Water Pressure (lb/sin)	7
Max. Temperature for Water Intake	140° F
Length Inlet Hose (in)	55 1/8"
Length Outlet Hose (in)	55 1/8"

DIMENSIONS & WEIGHT

Overall Appliance Dimensions (HxWxD) (in)	34 1/16" x 23 9/16" x 21 5/8"
Required Cutout Size (H*xWxD) (in)	34 1/16" x 24" x 24"
Adjustable Feet	Yes
Net Weight (lbs)	96 lbs

ACCESSORIES (INCLUDED)

Extra Tall Item Sprinkler, Wine Caddy

WARRANTY

Limited Warranty, Entire Appliance, Parts and Labor	2 Year
Limited Warranty for Microprocessor or Printed Circuit Board; Parts Only	3rd to 5th Year
Limited Warranty for Racks (Does Not Include Rack Components); Parts Only	3rd to 5th Year
Limited Warranty for Rust-through On Inner Tub Liner; Parts Only	Lifetime

*minimum height requirement

MODEL OPTIONS

There are four Thermador Dishwasher Series to choose from in the Collection—Emerald® (4-program), Topaz® (6-program), Sapphire® (6-program) and Star Sapphire® (8-program). All series models are available with a Masterpiece® or Professional Handle to perfectly match other Thermador appliances in your kitchen. All series have a custom panel option to fully integrate with your cabinetry. Be sure to reference the correct model information in this design guide.

INSTALLATION OPTIONS

CUSTOM DOOR PANELS (DWHD440MPR, DWHD640JPR, DWHD650JPR, DWHD860RPR)

Thermador custom panel dishwashers can be installed fully flushed for a seamless, integrated look.

Fully integrated models allow you to have a custom door panel made to match your cabinetry. The custom door can be a two-piece configuration to look like a drawer at the top and a cabinet door at the bottom or like a single full-length door. A template is included with the fully integrated models to explain the mounting procedure.

NOTE: These dishwashers can accept custom door panel weights ranging from 7 to 24 lbs.; however, the dishwasher comes from the factory ready for custom panel door weights from 11 to 18 lbs. If you plan on using a door panel that is not 11 to 18 lbs., please contact customer service at (800) 944-2904.

INSTALLATION CONSIDERATIONS

The information in this design guide provides key features, product dimensions, cutouts and installation specifications. Before installing a Thermador Dishwasher, be sure to verify the cabinet dimensions, electrical connections and water connections. Also, always consult with the installation manual packed with the product for complete details before installing.

Thermador Dishwashers are designed to be enclosed on the top and both sides by standard residential kitchen cabinetry.

If the dishwasher is to be installed in a corner, make sure that there is adequate clearance to open the door.

EMERALD® SERIES

- Minimum opening height: 33 7/8" (860 mm)
- Minimum opening width: 23 5/8" (600 mm) or 24 1/4" (616 mm) wide with decor strips removed

TOPAZ®, SAPPHIRE® AND STAR SAPPHIRE® SERIES

- Minimum opening height: 34 1/16" (865 mm)
- Minimum opening width: 24" (610 mm) or 24 1/4" (616 mm) wide with decor strips removed



All Thermador Dishwashers are ENERGY STAR® Qualified

ELECTRICAL SPECIFICATIONS

This appliance must be grounded to a metal, permanent wiring system, or an equipment grounding conductor must be run with the circuit conductors and connected to the equipment grounding terminal or lead on the dishwasher.

MODEL	REQUIRED CIRCUIT BREAKER
All Dishwasher Models	120V, 60 Hz, 12 A

WATER AND ELECTRICAL LOCATIONS

For proper dishwasher operation and appearance, ensure that the enclosure is square and has the dimensions shown. Plumbing and electrical service must enter shaded area.

Make required openings to allow for passage of the water, drain and electrical line. In order to avoid interference with the dishwasher when sliding it into the cabinet, place your openings within the dimensions shown.

Select a location as close to the sink as possible for easy access to water supply and drain lines.

NOTE: Plumbing installations will vary—refer to local codes. The maximum length of the drain hose, including hose leading to air gap (if any) is 150" (381 cm). Ensure a portion of the drain hose is raised at least 20" (51 cm) above the floor to ensure proper draining.

EMERALD® SERIES

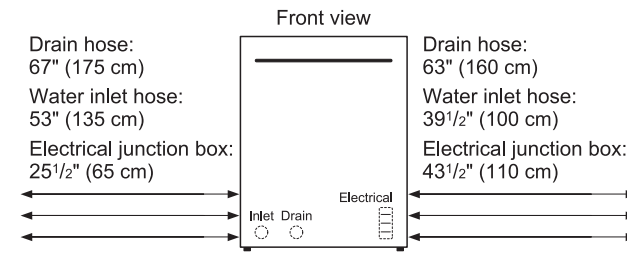

All connections are at the rear of the appliance. Extension for drain hose available as accessory. Power cord for connection to electrical outlet (3-prong plug) available as accessory.

TOPAZ®, SAPPHIRE® AND STAR SAPPHIRE® SERIES

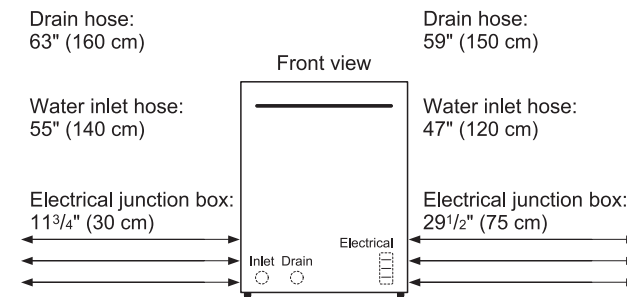

All connections are at the rear of the appliance. Extension for drain hose available as accessory. Power cord for connection to electrical outlet (3-prong plug) available as accessory.

DISHWASHER & CUTOUT DIMENSIONS

EMERALD DWHD440MFP & DWHD440MFM

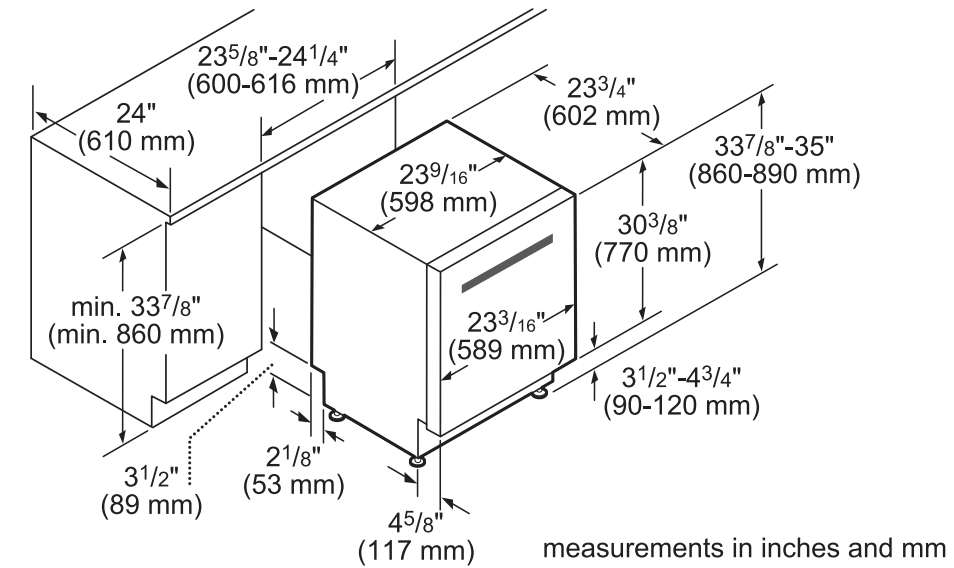

CUSTOM PANEL EMERALD DWHD440MPR

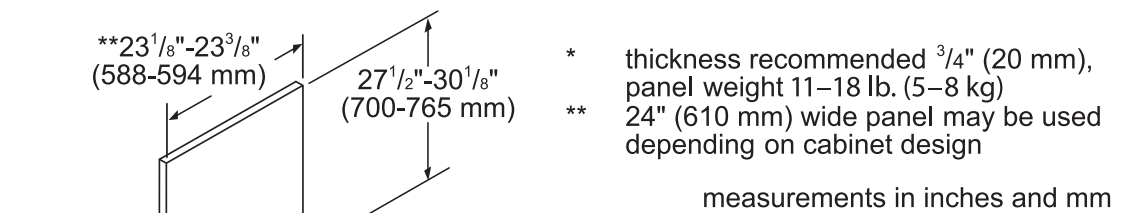
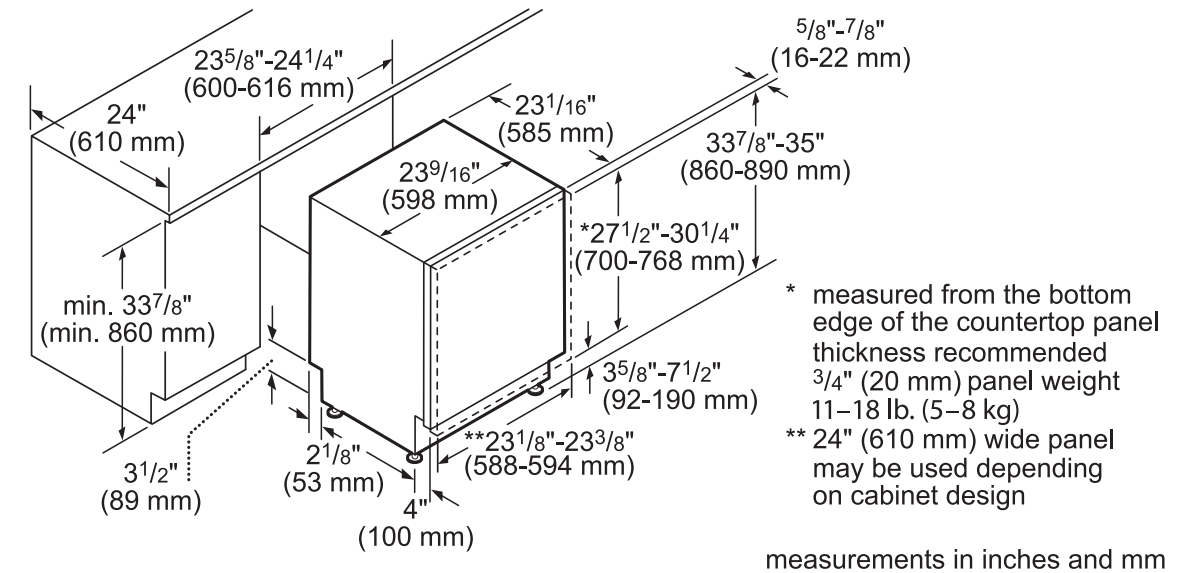

DISHWASHER & CUTOUT DIMENSIONS

TOPAZ DWHD640JFP & DWHD640JFM
SAPPHIRE DWHD650JFP & DWHD650JFM

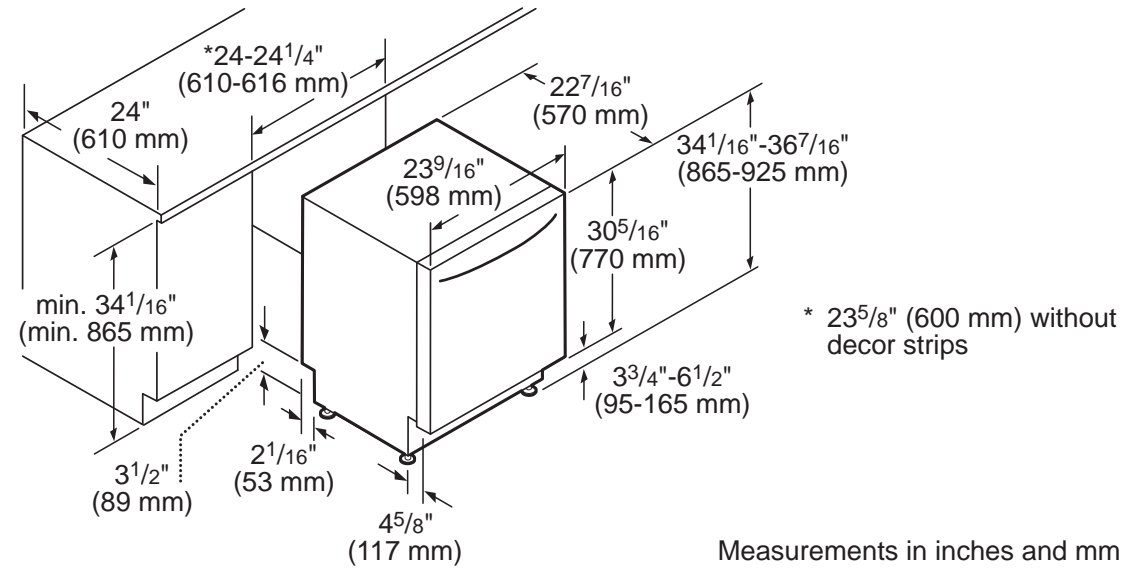

CUSTOM PANEL TOPAZ DWHD640JPR & SAPPHIRE DWHD650JPR

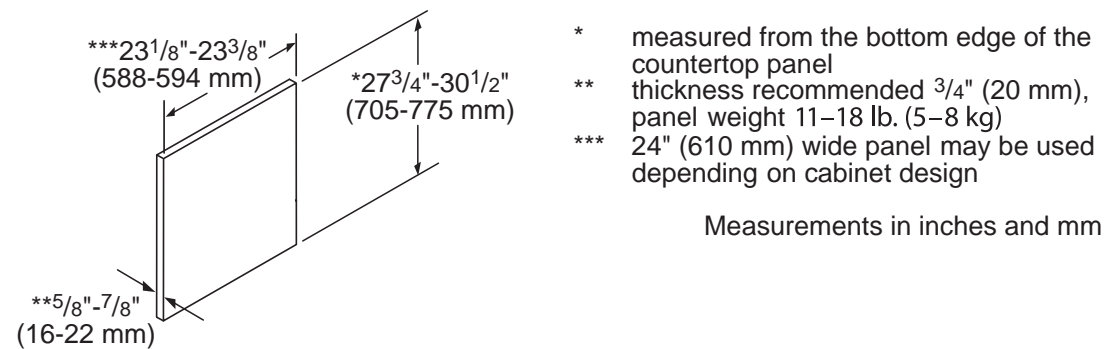
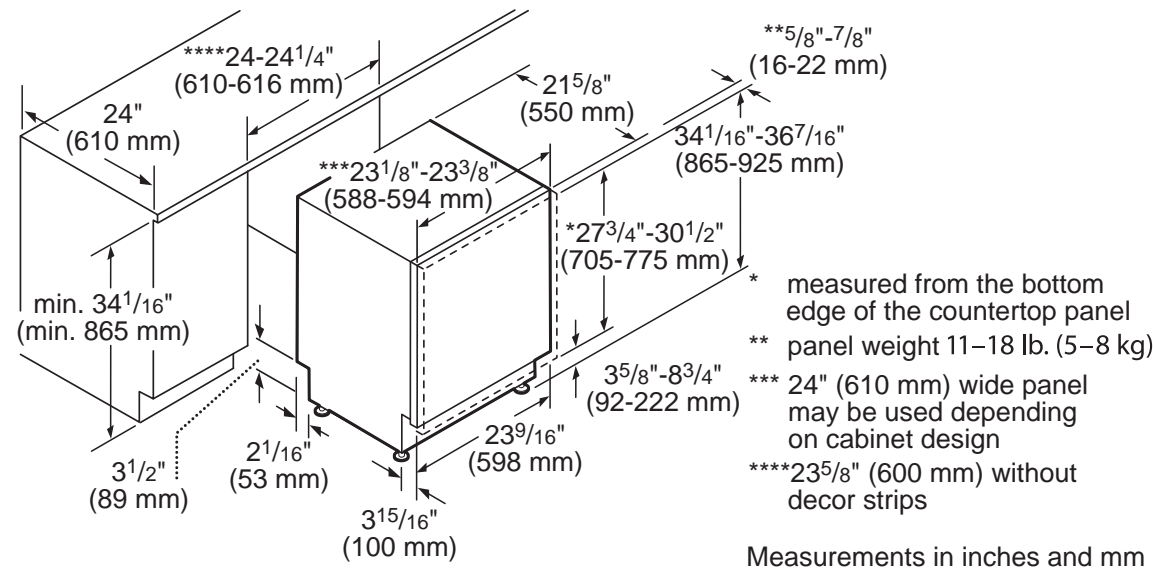

DISHWASHER & CUTOUT DIMENSIONS

STAR SAPPHIRE DWHD860RFP & DWHD860RFM

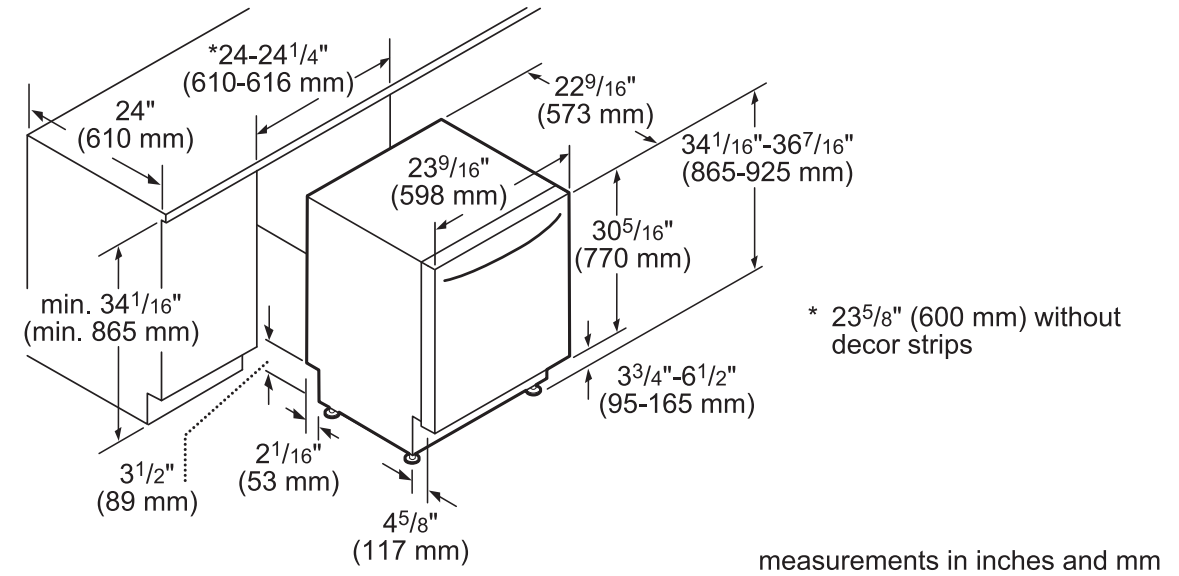

CUSTOM PANEL STAR SAPPHIRE DWHD860RPR

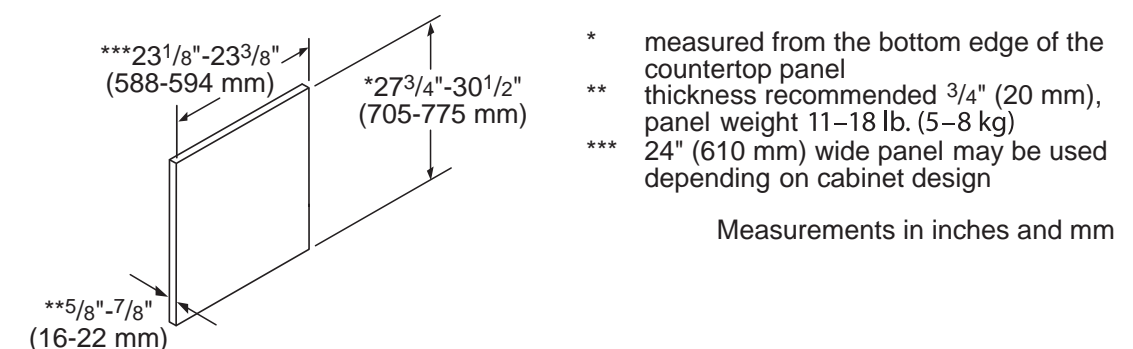
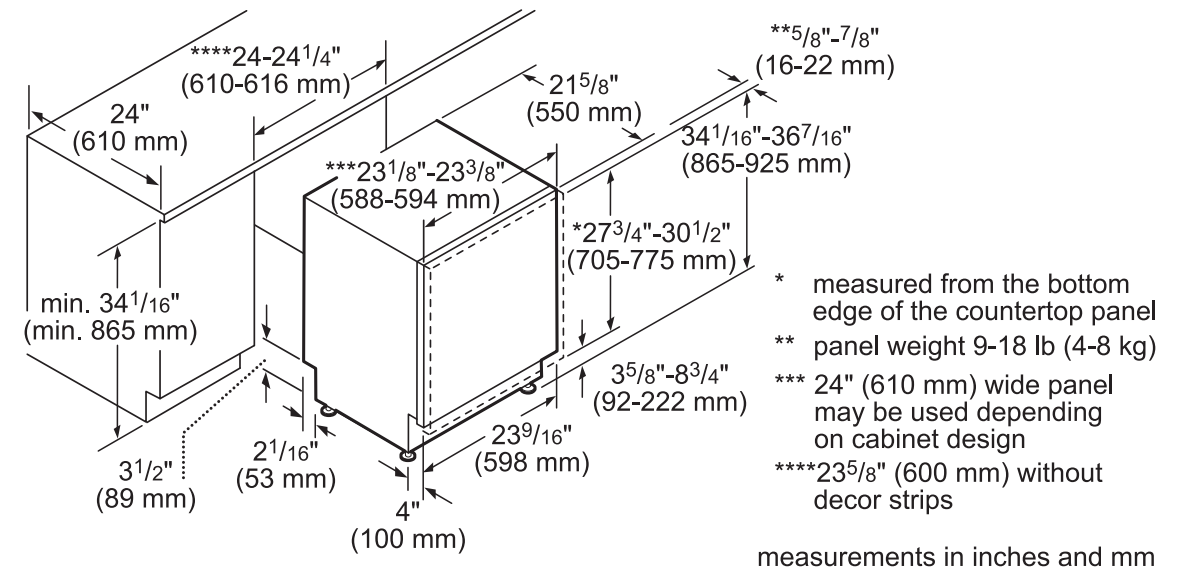



Thermador 

BUILT-IN COFFEE MACHINE

24-INCH

For those who love to entertain, a dinner party is never complete without espresso, coffee, or tea. Take your guests on a culinary journey they'll never forget with the Thermador® Built-In Fully Automatic Coffee Machine. With a sleek design, stainless steel finish, full-color LCD screen, flush installation, settings for large cups, hidden milk container and front access to coffee beans and water, it's every coffee connoisseur's—and tea lover's—dream.



KITCHEN DESIGN BY: HOOPER PATTERSON



★ COFFEE CUSTOMIZATION

Perfect for frequent selections, coffee customization settings store up to 8 personalized beverages with names so family members and houseguests can program their favorite drinks—from a single shot espresso, to tea, to extra-large cappuccinos.

★ AUTOMATIC DOUBLE SHOT BEVERAGES

For days that require an added dose of verve, Automatic Double Shot delivers an extra shot of espresso to select beverages. Enjoy a consistently strong flavor and aroma at the touch of a button.

★ AUTOMATIC CLEANING

Cleanup has never been easier. Using both hot water and steam, the machine features a fully automatic rinse program at turn-on and turn-off, so it's always ready for the next fresh-tasting pour.

★ CERAMIC DISK GRINDER

Enjoy freshly ground coffee for every cup with an exclusive Ceramic Disk Grinding System. Ceramic Disks deliver quality performance and minimize noise allowing for a smooth, consistent texture and flavor in every cup.

LCD DISPLAY

Full color LCD display illustrates beverage selection, including size and temperature control.

★ THERMADOR® EXCLUSIVE

TCM24RS 24-INCH BUILT-IN COFFEE MACHINE

MASTERPIECE® & PROFESSIONAL SERIES



FEATURES & BENEFITS

- Indulge yourself with up to 10 different beverages from your favorite caffè latte, cappuccino or your rich-flavor espresso
- Easy to read control panel with color LCD display gives complete digital information over every setting
- The fluid and versatile design of our Built-in Coffee Machine will perfectly coordinate with both of our Thermador product collections
- Prepare your favorite coffee drink like a professional barista with a simple touch of a button
- Store up to eight different beverages for quick and easy preparation of your favorite beverage

ACCESSORIES - INCLUDED

Stainless Steel Milk Container, Measuring Spoon

ACCESSORIES - OPTIONAL

30" Stainless Steel Trim Kit	TCMTK30RS
Stainless Steel Milk Container	11005967
Descaling Tablets	00311823
Cleaning Tablets	00311820
Water Filter	12008246

WARRANTY

Limited Warranty, Entire Appliance, Parts and Labor	2 Year
---	--------

★ THERMADOR® EXCLUSIVE

GENERAL PROPERTIES

Modes	Ristretto, Espresso, Espresso Macchiato, Coffee, Cappuccino, Latte Macchiato, Caffé Latte, Milk Froth, Warm Milk, Hot Water, Steam Clean, Clean, Descaling
Settings	One or Two Cups, Adjustable Cup Sizes, Brewing Temperature, Coffee Strength, Grind Adjustment
Programming	Personalized Beverages, Language, Light and Display Brightness, Water Hardness, Temperature, Time, Demo Mode, Child-proof Lock, Key Sounds
Sensor Alerts	Water Level, Bean Container, Drip Tray, Coffee Grounds
Beverages Available	10
Coffee Sizes	15
Memory Beverages	8
Double Cup Option	Yes
Coffee Strength Adjustment	6 Levels
Automatic Cleaning	Yes
Water Container Capacity (gal.)	5/8 gallon
Bean Container	1 lb.
Stainless Steel Milk Container	17 oz.
Powder Coffee	1 Scoop

DESIGN ELEMENTS

Display	Multilingual LCD Color Screen
Beverage Dispenser	Adjustable
Flush Installation	Yes
Milk Container	Stainless Steel

TECHNICAL DETAILS

Watts (W)	1,600 W
Circuit Breaker (A)	15 A
Current (A)	10 V
Volts (V)	120 V
Frequency (Hz)	60 Hz
Plug Type	NEMA 5-15R, 2-Pole 3-Wire Grounding
Power Cord Length (in)	39"
Energy Source	Electric
Pump Pressure (Bar)	275 psi (19 bar)

DIMENSIONS & WEIGHT

Overall Appliance Dimensions (HxWxD) (in)	17 7/8" x 23 3/8" x 14"*
Net Weight (lbs)	43 lbs*

*Not including transformer

24-INCH BUILT-IN COFFEE MACHINE

PLANNING INFORMATION

MODEL OPTIONS

The Thermador Built-in Coffee Machine is available with a stainless steel finish and coordinates with both the Professional and Masterpiece® series. An optional trim kit is available for 30" cutout installations.

INSTALLATION CONSIDERATIONS

The information in this design guide provides key features, product dimensions, cutouts and installation specifications. Before installing a Thermador Built-in Coffee Machine, be sure to verify the cabinet dimensions and electrical connections. Also, always consult with the installation manual packed with the product for complete details before installing.

IMPORTANT

Make sure there is adequate ventilation. To do this, remove the rear panel or cut out an opening of 19 11/16" x 15 3/4" (500 x 400 mm). There must be a gap of at least 1 3/8" (35 mm) between the wall and base of the unit or the rear panel of the unit situated above.

The ventilation slots and intake openings must not be covered. Also follow the installation instructions for the appliance situated above or below.

The ideal installation height for the fully automatic espresso machine, measured from the floor to the lower edge of the appliance, is 37 1/2" to 57" (95 – 145 cm).

COFFEE MACHINE & CUTOUT DIMENSIONS

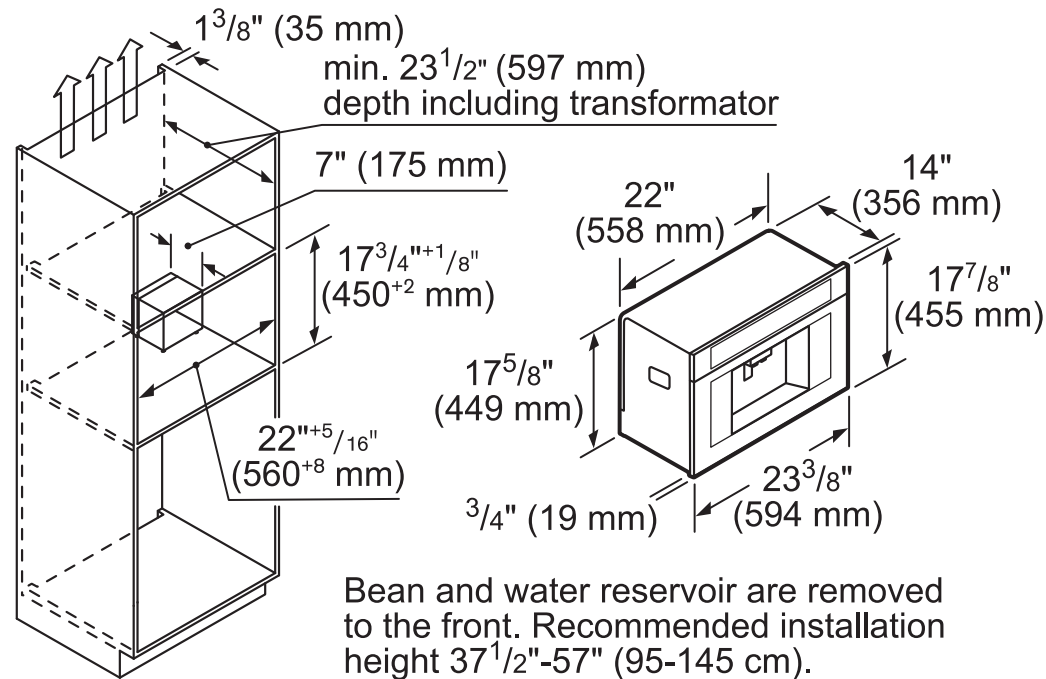

ELECTRICAL SPECIFICATIONS

Be sure your appliance is properly installed and grounded by a qualified technician. Installation, electrical connections and grounding must comply with all applicable local codes.

Thermador Built-in Coffee Machines are equipped with a NEMA 5-15R, 2-Pole 3-Wire plug and are designed to be connected to a 120V AC, 60Hz, single phase power supply.

MODEL	REQUIRED CIRCUIT BREAKER
TCM24RS	120 V, 60 Hz, 15 A

24-INCH BUILT-IN COFFEE MACHINE

INSTALLATION

CUTOUT DIMENSIONS WITH OPTIONAL 30-INCH TRIM KIT TCMTK30RS

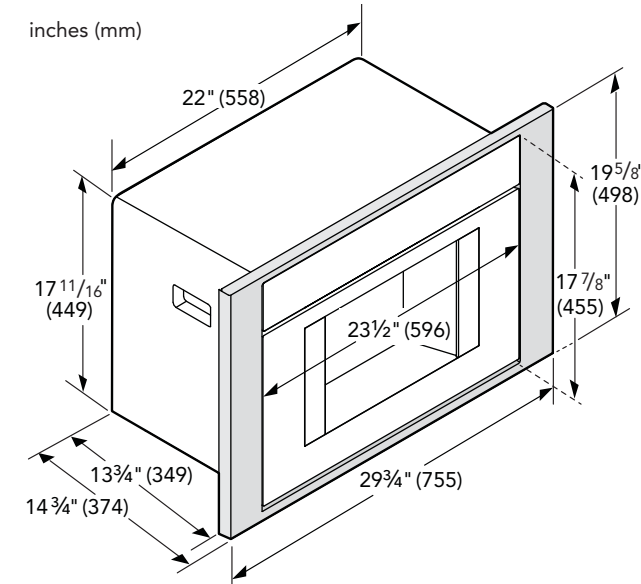
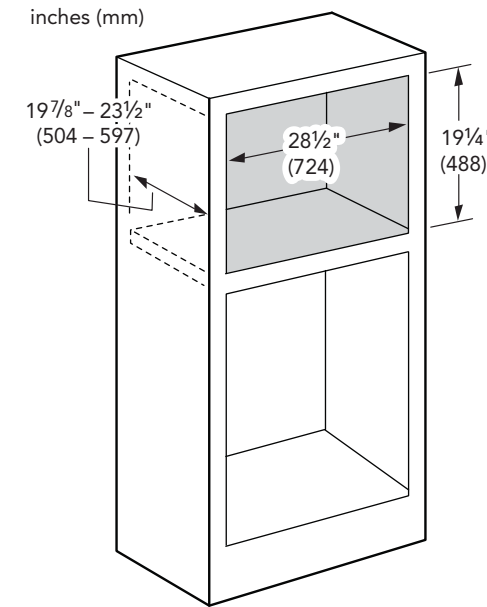

FLUSH INSTALL WITH OPTIONAL 30-INCH TRIM KIT TCMTK30RS

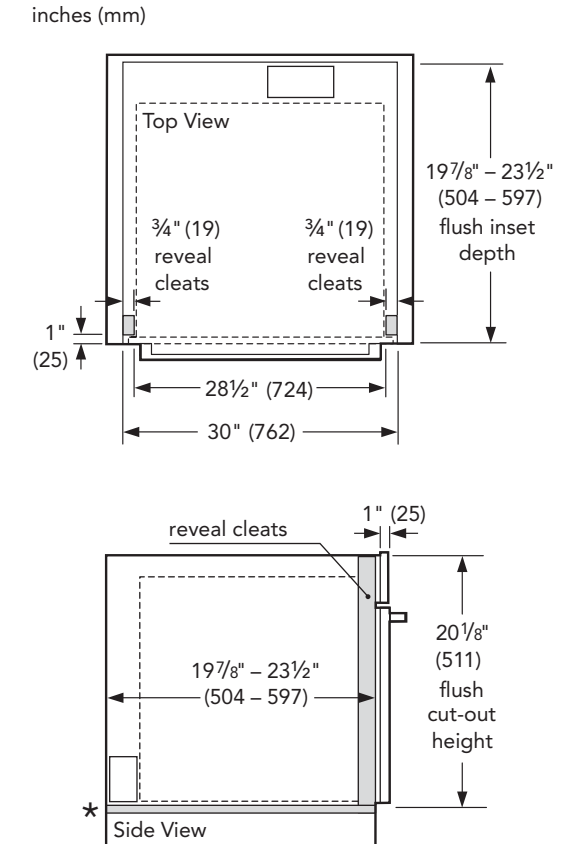

NOTE: * Flush installation requires a 5/16" (8 mm) high x 28 1/2" (724 mm) wide x 22 1/2" (571 mm) deep baseplate underneath the unit body.

PRO GRAND® RANGES

	PRD366JGU	27
	PRD364JDGU	28
	PRD364NLGU	29
	PRG366JG	30
	PRL366JG	31
	PRG364JDG	32
	PRG364NLG	33
	PRL364JDG	34
	PRL364NLG	35
	PRD486JDGU	36
	PRD486NLGU	37
	PRD484NCGU	38
	PRD484JDSGU	39
	PRD48NLSGU	40
	PRD48NCSGU	41
	PRG486JDG	42
	PRG486NLG	43
	PRL486JDG	44
	PRL486NLG	45
	PRD606RCG	46
	PRD606REG	47
	PRD606RCSG	48
	PRD606RESG	49

PRO HARMONY® RANGES

	PRD304GHU	64
	PRD305PH	65
	PRD364GDHU	66
	PRD364NLHU	67
	PRD366GHU	68
	PRD486GDHU	69
	PRD486NLHU	70
	PRD484NCHU	71
	PRG304GH	72
	PRL304GH	73
	PRG305PH	74
	PRL305PH	75
	PRG366GH	76
	PRL366GH	77
	PRG364GDH	78
	PRG364NLH	79
	PRL364GDH	80
	PRL364NLH	81
	PRG486GDH	82
	PRG486NLH	83
	PRL486GDH	84
	PRL486NLH	85

PROFESSIONAL RANGETOPS

	PCG305P	100
	PCG364GD	101
	PCG364NL	102
	PCG366G	103
	PCG486GD	104
	PCG486NL	105

BUILT-IN OVENS

	PSO301M	121
	MES301HP	122
	MES301HS	123
	POD301J	124
	MED301JP	125
	ME301JP	126
	MED301JS	127
	MED271JS	128
	ME301JS	129
	PODC302J	130
	MED302JP	131
	ME302JP	132
	MED302JS	133
	ME302JS	134
	MED272JS	135
	PODM301J	136
	MEDMC301JP	137
	MEDMC301JS	138
	PODMW301J	139
	MEDMCW31JP	140
	MEDMCW31JS	141
	MEDMCW71JS	142

INDUCTION COOKTOPS

	CIT36XKB	159
	CIT36XKBB	160
	CIT367TGS	161
	CIT367TG	162
	CIT367TMS	163
	CIT367TM	164
	CIT365KM	165
	CIT365TB	166
	CIT304KM	170
	CIT304TM	171
	CIT304TB	172

GAS COOKTOPS

	SGSL365KS	178
	SGSX365FS	179
	SGS365FS	180
	SGSX305FS	181
	SGS305FS	182
	SGS304FS	183

ELECTRIC COOKTOPS

	CET366TB	192
	CEM365NS	193
	CET305TB	194
	CEM304NS	195

WALL HOODS

	PH36GS	228
	PH42GS	229
	PH48GS	230
	PH54GS	231
	PH60GS	232
	PH30HS	233
	PH36HS	234
	PH48HS	235
	HPWB30FS	236
	HPWB36FS	237
	HPWB48FS	238
	HMWN30FS	239
	HMWN36FS	240
	HMWN48FS	241
	HMWB30FS	242
	HMWB36FS	243

CHIMNEY WALL HOODS

	HPCN36NS	250
	HPCN48NS	251
	HPCB36NS	252
	HPCB48NS	253
	HMCN36FS	254
	HMCN42FS	255
	HMCB36FS	256
	HMCB42FS	257
	HDDW36FS	258

ISLAND HOODS

	HPIN42HS	264
	HPIN48HS	265
	HPIB42HS	266
	HPIB48HS	267
	HMIB40HS	268

CUSTOM HOOD INSERTS

	VCIN36JP	274
	VCIN48JP	275
	VCIN54JP	276
	VCIN60RP	277
	VCIB36JP	278
	VCIB48JP	279
	VCIB54JP	280
	VCI230DS	281
	VCI236DS	282
	VCI248DS	283

DOWNDRAFT HOODS

	UCVM30FS	292
	UCVM36FS	293

WARMING DRAWERS

	WD27JS	300
	WD30JS	301
	WD30JP	302
	WDC30JS	303
	WDC30JP	304
	WDC30J	305
	WDC36JP	306
	WDC36J	307

BUILT-IN MICROWAVES

	MD24JS	315
	MD30RS	316
	MBES	317
	MCES	318

FRESH FOOD COLUMNS

	T23IR900SP	340
	T24IR900SP	341
	T30IR900SP	342
	T36IR900SP	343

FREEZER COLUMNS

	T18ID900LP	344
	T18ID900RP	345
	T24ID900LP	346
	T24ID900RP	347
	T18IF900SP	348
	T24IF900SP	349
	T30IF900SP	350
	T36IF900SP	351

WINE PRESERVATION COLUMNS

	T18IW900SP	352
	T24IW900SP	353

BOTTOM FREEZERS

	T30IB900SP	354
	T36IB900SP	355
	T36IT900NP	356
	T30BB920SS	357
	T30BB910SS	358
	T36BB920SS	359
	T36BB910SS	360
	T36BT920NS	361
	T36BT910NS	362

UNDER-COUNTER REFRIGERATION

	T24UW820LS	406
	T24UW820RS	406
	T24UW810LS	407
	T24UW810RS	407
	T24UW800LP	408
	T24UW800RP	408
	T24UR820DS	409
	T24UR810DS	410
	T24UR800DP	411

DISHWASHERS

	DWHD440MFP	416
	DWHD440MFM	417
	DWHD440MPR	418
	DWHD640JFP	413
	DWHD640JFM	414
	DWHD640JPR	415
	DWHD650JFP	410
	DWHD650JFM	411
	DWHD650JPR	412
	DWHD860RFP	407
	DWHD860RFM	408
	DWHD860RPR	409

BUILT-IN COFFEE MACHINE

	TCM24RS	443
---	---------	-----

WARRANTY

	449
--	-----

EXPERIENCE THERMADOR®

Thermador is committed to supporting you throughout all of your culinary endeavors. Whether you would like to research our products, learn more about the use and care of your appliances, or spice up your next dinner party with new and unique recipes, explore a world of resources at thermador.com.

Take Us With You

Visit the App Store or Google Play to download our apps, including the Thermador Kitchen Ideas & Lookbook and the Thermador Kitchen Design and Planning Guide.



Exceptional Customer Care 24/7

For dedicated customer service on any Thermador product: call 1-800-735-4328 or contact us at thermador.com.

Follow Us:

-  thermador.com/blog
-  [@thermador](https://www.facebook.com/thermador)
-  [@thermadorhome](https://www.instagram.com/thermadorhome)
-  [@thermador](https://twitter.com/thermador)
-  [@thermador](https://www.pinterest.com/thermador)
-  [youtube.com/thermadorhome](https://www.youtube.com/thermadorhome)

PRODUCT WARRANTY SUMMARY

PROFESSIONAL RANGES

Limited warranty, entire appliance, parts and labor (2 year)

PROFESSIONAL RANGETOPS

Limited warranty, entire appliance, parts and labor (2 year)

BUILT-IN OVENS

Limited warranty parts and labor (2 year)

INDUCTION COOKTOPS

Limited warranty, entire appliance, parts and labor (2 year)

GAS COOKTOPS

Limited warranty, entire appliance, parts and labor (2 year)

ELECTRIC COOKTOPS

Limited warranty, entire appliance, parts and labor (2 year)

VENTILATION

Limited warranty, entire appliance, parts and labor (2 year)

WARMING DRAWERS

Limited warranty, entire appliance, parts and labor (2 year)

BUILT-IN MICROWAVES

Limited warranty, entire appliance, parts and labor (2 year)

REFRIGERATION

Limited two-year warranty, entire appliance, parts and labor on any part of the refrigerator that fails because of a manufacturing defect

Limited warranty for sealed refrigeration system*; parts and labor (3rd to 6th year)

Limited warranty for sealed refrigeration system*; parts only (7th to 12th year)

*Sealed refrigeration system includes compressor, evaporator, condenser, dryer/strainer and connection tubing

DISHWASHERS

Limited warranty, entire appliance, parts and labor (2 year)

Limited warranty for microprocessor or printed circuit board; parts only (3rd to 5th year)

Limited warranty for racks (does not include rack components); parts only (3rd to 5th year)

Limited warranty for rust-through on inner tub liner; parts only (Lifetime)

BUILT-IN COFFEE MACHINES

Limited warranty, entire appliance, parts and labor (2 year)



These warranties give you specific legal rights and you may have other rights that vary from state to state. Limited Warranty from Date of Purchase. For complete warranty details, refer to your Use & Care manual, or ask your dealer.

Specifications are for planning purposes only. Refer to installation instructions and consult your countertop supplier prior to making counter opening. Consult with a heating and ventilation engineer for your specific ventilation requirements. For the most detailed information, refer to installation instructions accompanying product or write to Thermador® indicating the model number. Specifications are correct at time of printing. Thermador reserves the right to change product specifications or design without notice. Some models are certified for use in Canada. Thermador is not responsible for products that are transported from the U.S. for use in Canada.

©2017 BSH Home Appliances Corporation.

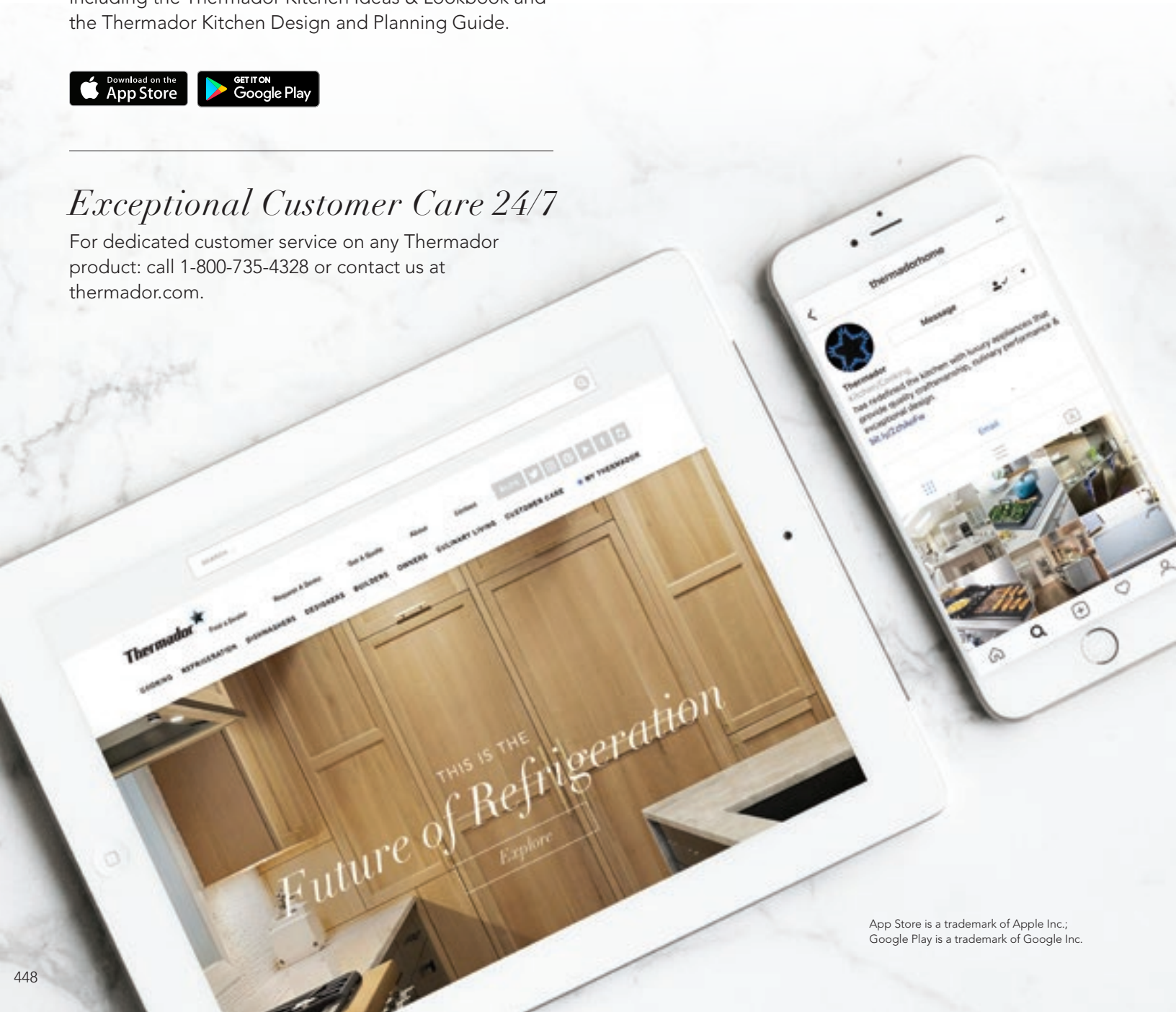

App Store is a trademark of Apple Inc.;
Google Play is a trademark of Google Inc.



1 800 735 4328

USA THERMADOR.COM
CANADA THERMADOR.CA

©2017 BSH HOME APPLIANCES CORPORATION. ALL RIGHTS RESERVED.
digital ebook-11/17