



SIEMENS

Corporate Showroom and Experience Centres:

Mumbai:
BSH Household Appliances Manufacturing Pvt. Ltd.
Arena House, II Floor, Main Building,
Plot No.103, Road No.12,
MIDC, Andheri, Mumbai - 400093. India.

Bangalore:
BSH Household Appliances Manufacturing Pvt. Ltd.
No - 8, GF, 15th Cross, 6th Phase,
J P Nagar, Bangalore - 560 078. India.

Delhi NCR:
BSH Household Appliances Manufacturing Pvt. Ltd.
NIIT, Tapasya Building, 2nd Floor,
Plot No - 5, EFGH, Sector 126, Greater Noida, Expressway, Noida - 201313, UP. India.

Siemens toll free number - 1800 209 1850
(Monday to Saturday: 8am to 8pm)

www.siemens-home.bsh-group.com/in

BSH Group is a Trademark Licensee of Siemens AG.
Valid from February, 2018.

Important Notes:
Certain appliances shown in this catalogue may not be available in India. Model numbers and specifications are for reference only and subject to change without prior notice. Please contact your local Siemens retailer for the latest information.

BSH Household Appliances Manufacturing Pvt. Ltd. reserves the right to change specifications without notice, in the interest of technological progress.

While every effort has been made to ensure that all specifications and descriptions are correct at the time of going to press this brochure should not be regarded as infallible guide nor as an offer of sale for a particular product. Due to variables in the reproduction process, colours of actual products may vary slightly from those depicted. We recommend a visit to a Siemens dealer to confirm that specifications and colours are to your satisfaction.

All descriptions and installation diagrams are intended as a guide only. For additional technical information, full dimensional and installation details, please refer to the instruction manual supplied with the appliance.

All rights reserved. No part of this publication may be reproduced in any form by any means without the prior written permission of BSH Household Appliances Manufacturing Pvt. Ltd. (EOE)

SIEMENS

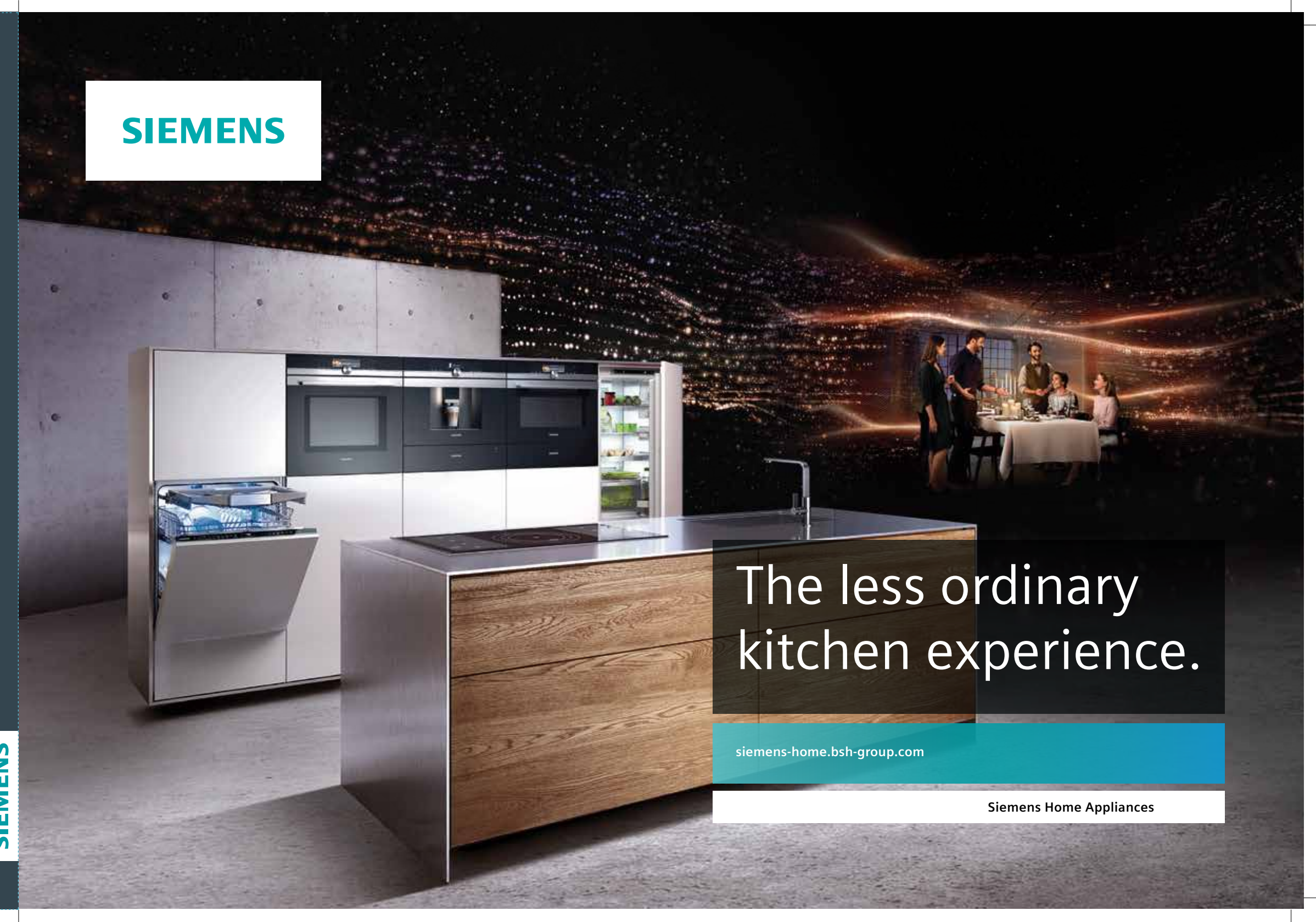

The less ordinary
kitchen experience.

siemens-home.bsh-group.com

Siemens Home Appliances

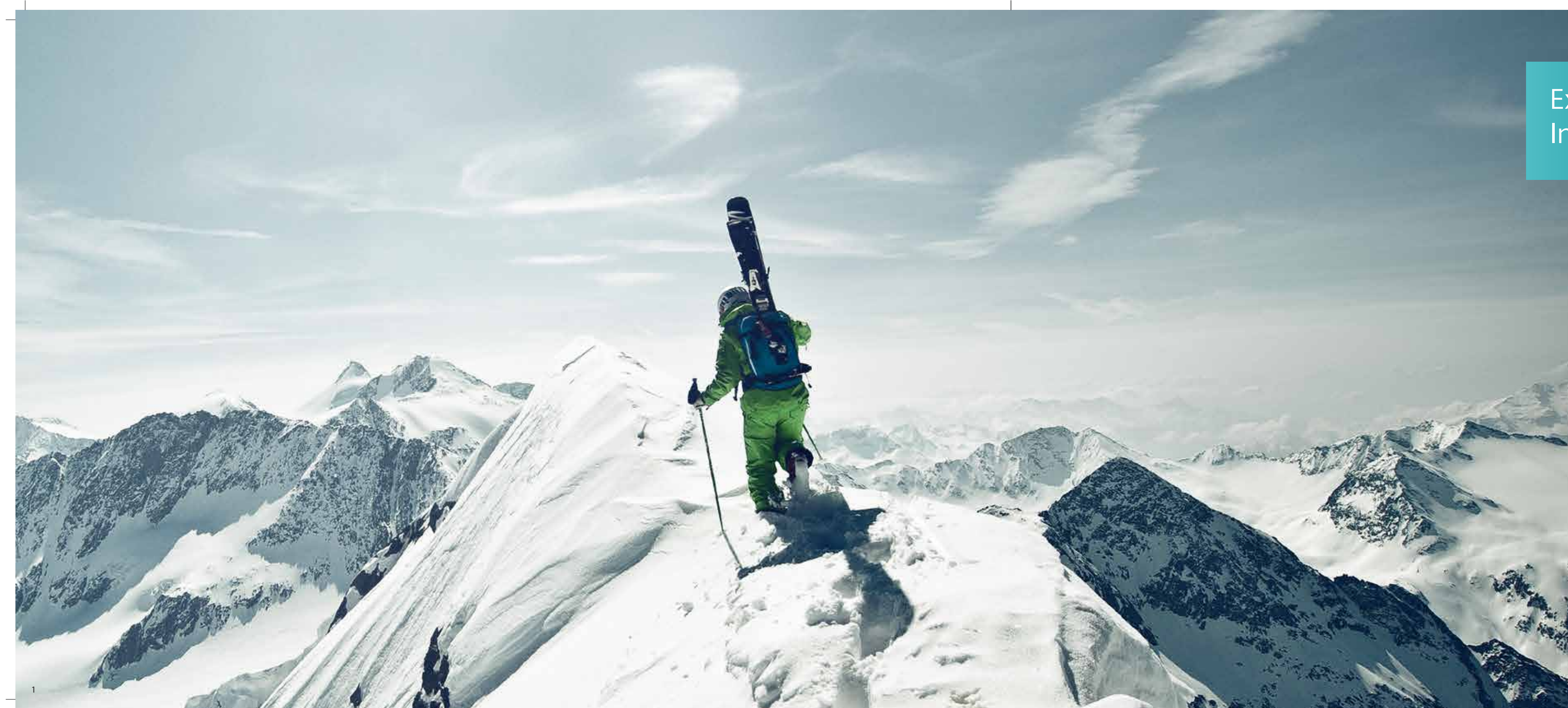

Experience your kitchen. In an extraordinary way.

Imagine a world where functional doesn't mean boring, where outstanding becomes the standard and where you are no longer pressed for time.

Imagine your everyday life transforming into a world of possibilities. At Siemens Home Appliances, we know that these possibilities begin at home.

Through our rich legacy of German technology, foresightedness and innovation in leading technology we enable our consumers to experience the future of living, today. Our products contribute to your metropolitan lifestyle with their aesthetics and timeless design. And, they create opportunities to enrich your life with inspiring moments.

This is what we do. This is why we exist: to create exciting possibilities.

Welcome to the new world of Siemens. For a life less ordinary.

For more than 165 years,
Siemens has been a pioneer.

"We don't just pursue visions – we make dreams a reality."

– Werner von Siemens

Our story began in 1847 in Berlin, Germany. When the founder of our company, Werner von Siemens, came to Berlin he had nothing more than just the dream "of an enterprise that, through its own inventions and its entrepreneurial vision, contributes to enhancing the knowledge of humanity."

For more than 165 years, Siemens has been a German industrial and technological brand, spanning the entire breadth of the electrical engineering industry. No wonder, with a series of inventions that have truly revolutionized the life of mankind, Siemens is most decisively Europe's Leading Built-in Appliance brand today.

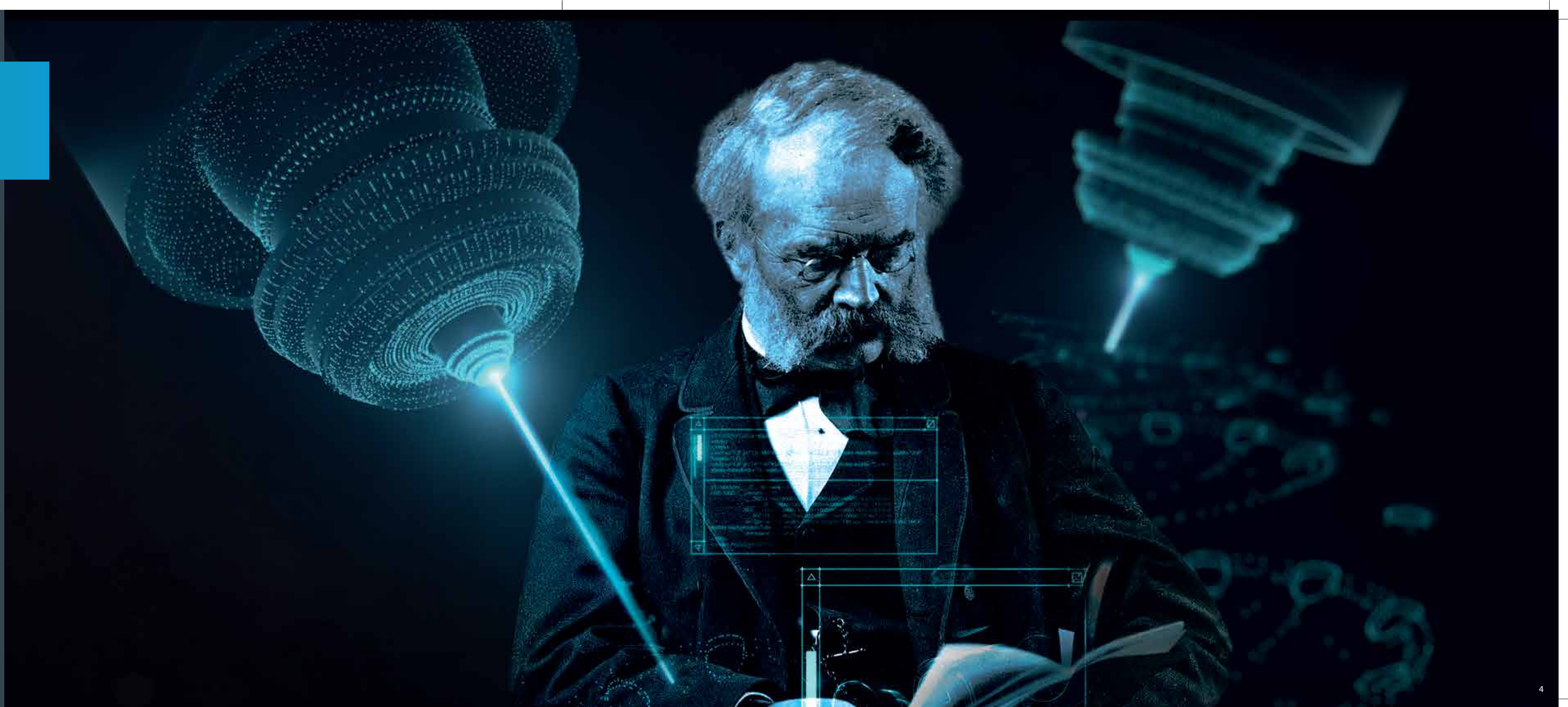



The Future of Innovation. Since 1847.

For more than 150 years, Siemens engineers are focusing on one thing: the future. From first electric cooker to intelligent iSensonic technology to our latest home connect functionality, Siemens has initiated a new era and has laid the foundation for the level of comfort we know today.

Some innovations that have changed the way we live.

- 1847 - Pointer telegraph lays the foundation for Siemens & Halske
- 1866 - Werner von Siemens discovers the dynamo-electric principle
- 1906 - Dust suction pump, an early vacuum cleaner
- 1913 - Siemens Small Appliances Works starts manufacturing irons, electric kettles, hotplates and heaters
- 1934 - Quiet vacuum cleaner
- 1940 - Compressor refrigerators
- 1956 - Top-loader washing machine
- 1984 - Combined microwaves
- 1989 - Washing machines with Aquatronic, saving 50% water and 40% energy
- 1999 - Fully automatic coffee maker
- 2008 - Super energy-efficient tumble dryers with heat pump technology
- 2012 - Free induction cooktop
- 2015 - Home Connect functionality across all product categories

Designs where form follows function.

"At Siemens, design always starts with technological innovations, which requires new approaches to design."

– Gerhard Nussler, Head of Design, Siemens.

Siemens is known for its contemporary yet timeless iconic design sensibilities where 'form follows function'. Siemens develops and designs technological worlds where progress can be experienced first hand and design plays a key role. In fact, the iconic designs of Siemens home appliances are minimalist, puristic and create a masterful profile in a timeless yet modern way.

Siemens home appliances don't just look fantastic – they are fantastic.

You'll enjoy the clear bold lines, high quality material and high precision craftsmanship of the Siemens design for years to come. Many design juries agree. No wonder, Siemens home appliances have won the following design awards:

- Interior innovation award – 2015
- iF Products Design Award
- iF Product Design Award Gold
- Red dot Design Award
- Red dot 'Best of the Best'
- German design award 2015





Where built-in appliances personify knowledge and expertise.

Siemens, being a built-in expert will take care of everything for you, from delivery to installation. We will look after every step, so that you can sit back and relax.

Wider service network

We have the largest distribution network in India via our kitchen dealers. With an impressive presence across the length and breadth of India at all major cities, we are geared to change the way India savours the cooking experience.

Professional installation

At Siemens, we ensure all installations are carried out keeping in mind the highest quality standards. The built-in appliances are well fitted into the kitchen cabinets. What's more, we even test your appliance after installation and also offer you a briefing on basic setting and operation.

Choosing the most suitable appliances

We learn from our customers and take their cooking habit into consideration when it comes to choosing appliances. Not to mention, we will also take note on the layout of your kitchen to ensure your appliances can be fully utilised. At Siemens, our experienced team could give valuable advice and make certain your appliances are your best choice.

Kitchen planning

At Siemens, we understand that working on the kitchen can be quite tiring if it is not well-planned, especially from an ergonomic point of view. Our expert could pay an onsite visit before installation and work hand-in-hand with your kitchen specialist to create a perfect and harmonious kitchen for your home.

At Siemens, we are determined to bring you a worry-free and enjoyable product experience.

iQ700 Range Outstanding. Built-in.

Seamless design that complements every kitchen. All appliances in the iQ700 Built-in range can be combined perfectly with each other. The iQ700 compact ovens, ovens, coffee centres and warmer drawer all line up, thanks to the coordinated front panels. It doesn't matter whether you arrange the appliances horizontally or vertically: the result always pleases the eye. Even our iQ700 hoods have the same front panel design for a coordinating look throughout your kitchen.

Each oven features blue illuminated hard key buttons, integrated into a sleek, chrome-effect strip that provides the most important operations from turning the oven on to starting your cooking. The central stainless steel disc control is a constant design feature combined with the touch screen navigation, this method of operation is both familiar and intuitive.

The trend setting iQ700 ovens feature a smaller profile oven door handle that blends into the stainless steel panels to offer more flexibility with handleless kitchen design, yet still having the highest build quality and feel. While the precise lines of the black glass and stainless steel create a definitive aesthetic worthwhile of any modern, less ordinary kitchen.

Ovens | Microwaves | Hobs | Hoods | Coffee Centre | Warmer Drawer
Dishwasher | Refrigerators & Wine Cooler.





Table of Contents

1	Ovens and Microwaves	15 - 42
2	Hobs	43 - 70
3	Hoods	71 - 90
4	Coffee Center	91 - 96
5	Warmer Drawers	97 - 100
6	Dishwashers	101 - 112
7	Refrigerators and Wine Cooler	113 - 138
8	Installation Guide	140 - 174

Ovens

Simply the best.

With many clever, innovatively designed functions, Siemens built-in appliances make cooking much simpler and more relaxing. Siemens ovens offer a wide choice of cooking functions, making them a perfect companion when you cook. The range of Siemens ovens boasts of unique features like TFT colour-touch display, 4D Hot Air, varioSpeed, coolStart and activeCleaning for ease of cooking and cleaning. In other words, infusing a new kind of convenience that will turn around your kitchen into a space for unforgettable experiences.

Single Ovens | Combination Microwave Oven with pulseSteam | Combi Microwave Ovens | Combi Steam Ovens | Microwaves



One touch. That's all it takes to prepare culinary delights.

Featuring different display screen sizes.



Say goodbye to multiple dials and printed icons: TFT – Touch display
The TFT-Touch display allows you to operate the oven and choose its unique features with ease – thanks to the combination of the bright colour display, touch navigation and intuitive menu structure.



Designed to give you complete control over your cooking: TFT- Display
The TFT-Display with clearText makes it easy to read information from every angle. The intuitive menu guidance allows you to control oven functions in just a few simple steps.



We're putting steam front and centre.

Featuring two models with simple to use steam functionality, iQ700 is taking this technique from a specialty and moving it to the forefront of home cooking.

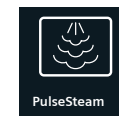

Flawless blending of various techniques: **PulseSteam**

When food needs browning or crisping, the injection of steam alongside traditional hot air is the technique of choice for the most desirable results. With pulseSteam, you can prepare perfectly crispy and juicy dishes simply and efficiently, whilst the full-size cavity models provide even more freedom and flexibility.

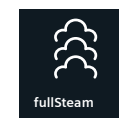

Perfectly retains the goodness and replaces unhealthy food: **fullSteam**

A healthy alternative to cooking with fats and oils, fullSteam enables you to cook with 100% steam, ensuring all the flavour, moisture and goodness in your food is retained. It is also perfect for reheating and regenerating food without losing colour or nutrition.

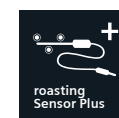

Achieve the best roasting results – easier than ever before: **roastingSensor Plus**

Thanks to three measuring points, the innovative roasting thermometer is able to precisely and reliably measure the core temperature of your dishes. This allows you to use it with a wider range of foods and stops inaccurate temperatures that a single point would otherwise provide. Ideal for meat, poultry and fish, it can even be combined with the integrated microwave and the pulseSteam function. Without the need to keep checking, the roastingSensor gives you the freedom to get on with the rest of your cooking.

With our Steam ovens, the aromas don't mix.

Now you can cook multiple dishes at one go without worrying about the intermingling of aromas. Cook to your heart's delight and save time.



When time is getting away from you, take it back.

Faster cooking options for a life less ordinary.

If you prefer to spend most of your day catching your dinner, and less time cooking it, you don't have to compromise on enjoying a beautifully prepared meal. The Siemens iQ700 range gives you faster, more flexible cooking options, so you can command your time as you wish.



varioSpeed: all the goodness you demand, in up to 50% less time

Twice as fast in combination: by additionally activating the integrated microwave to complement the conventional manner of heating, you can speed up the preparation of your dishes if necessary and always with the perfect quality you would expect. Save up to 50% of the time usually needed and use it at your own disposal.

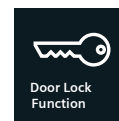

Safety like never before: Door Lock Function

Siemens Combi Microwave Ovens have an appliance door lock in addition to the control panel lock. This is activated automatically when the temperature in the cooking compartment reaches approximately 50°C for more safety.



Pre-installed settings guarantee the best results for numerous dishes: cookControl Plus

Depending on the dish chosen, the optimum setting is recommended by the oven to achieve perfect results. You can achieve perfect baking and roasting results, even as a beginner. Simply select a dish on the interface and then our oven recommends the best matching technology.



Safety for you and your loved ones: Childproof lock

With our childproof lock, you can rest assured that your children will be safe. This lock prevents children from accidentally switching it on as the oven will not react to any settings. The timer and clock can also be set when the childproof lock has been activated.

Ovens so intelligent, they know exactly what's inside.



Cook on any shelf, and trust in the result: 4D Hot Air

You can now choose which shelf you want to cook your food on with the greatest possible flexibility between the 1st - 4th shelf. The innovative technology of the fan motor enables optimum heat distribution by circulating hot air clockwise and anti-clockwise. The fan wheel is now driven by the quieter and more efficient iQdrive motor.



Quiet and gentle opening and closing - thanks to intelligent damping: softMove Door

This function has been designed for a relaxed operation of the oven without pushing and pulling. The intelligent damping mechanism ensures that the oven door opens and closes gently without making noise.



Frozen food? Place it straight in the oven: coolStart

No more pre-heating your oven. No need for thawing. Cooking frozen food in the oven is now faster than ever, thanks to the intelligent coolStart function, which condenses the whole process into a single cooking session, with no compromise on results.



Because we understand that warm food tastes the best: Sabbath Setting

The oven is automatically set to conventional heat at a temperature of 85°C. You can adjust the Sabbath Setting duration for between 24 to 73 hours. This has been specially designed to keep pre-heated food warm.

Automatic safety switch off

If you don't change the cooking time while cooking or baking, the words "Automatic switch off" will appear in the TFT display and the oven will switch itself off. This is an additional safety feature, for additional peace of mind.



Telescopic rail system with 'stop' function: Telescopic Rails

The effortless gliding shelves reduce your work for those heavy roasts, while the telescopic rail is an ideal option if your oven has to be tucked away. This comes handy when you have heavy food items kept inside the oven. For ease and safety, the new 'stop' function locks the extended rails in place: to release, give it a light push. These rails are also pyrolytic proof and are fully compatible with Ovens and Combi Microwave Ovens.



Quadruple glazed coolGlass door with heat reflective glass: coolGlass Door

For worry-free baking, the Siemens iQ700 ovens have been designed in such a way that the outer glass door stays cool even during baking. The temperature of the door can be as low as 30°C during cooking and does not exceed 60° C even during the pyrolytic cleaning (with temperature exceeding 500°C). The patented quadruple layered glass doors keep the temperature on the outside as low as possible.



Every model in a great light: Illumination LEDs

Being in full control means having a better view of what's happening inside. Whether it's the standard halogen, the LED, or the seriously impressive Multilevel LED-illumination, iQ700 ovens provide a view to whatever you are creating.



Dough Rise

You can prove yeast dough in your appliance quicker than at room temperature with the use of the top/bottom heating function. There are several dough rise-levels with different steam intensities available. The best part is that the dough won't dry out and will stay elastic.

4D Hotair: Perfect even baking at all levels.

Cook on any shelf, and trust in the result. Now you have the flexibility to place your food on any shelf, without having to worry about evenness of cooking. By using innovative fan technology which rotates clockwise and anticlockwise to distribute heat around and between the trays in an optimal way, 4D Hot Air gives you more confidence, gives you perfect result with greater flexibility and most importantly the most desirable results. Thanks to the improved heat distribution delivered by the symmetric, alternating new fan driven by the quiet and efficient iQdrive motor. Thus, the dish can be placed from 1-4 on any level - and will always achieve the desired result in the most energy efficient way.



Cooking is always fun and effortless.

With the many clever, innovative functions, Siemens built-in appliances make cooking much simpler and more relaxing. Siemens Ovens, Combi Microwave Ovens and Combi Steam Ovens offer 13 cooking functions providing ideal options for all types of foods.



4D Hot Air*

For baking and roasting on one or more levels. The fan distributes the heat evenly around the compartment for consistent cooking.

Biscuits | Macaroons | Pastries | Garlic bread



Top/bottom heating - Eco

For energy optimised cooking of selected dishes. Heat is emitted evenly from above and below.

Bread | Bread rolls | Meat | Fish



Hot Air - Eco

For energy optimised cooking of selected dishes on one level without preheating. The fan distributes the energy optimised heat from the ring heating element in the back wall evenly around the cooking compartment.

Cakes | Muffins | Biscuits



Circulated air grilling*

The grill heating element and the fan switch on and off alternately. The fan circulates the hot air around for crisping the food.

Roasting | Whole Fish | Small cuts of meat | Potatoes



Top/bottom heating*

For single centre shelf cooking to give you a moist, even browning and crispier results.

Meat | Fruit Pies | Fruit cakes



Large area grill*

The whole area of the grill becomes hot, giving you precision heating for the full width of the grill.

For Grilling and Browning flat items - Steaks | Sausages | Bread



Small area grill*

Only the center of the grill becomes hot, when you want to cook smaller quantities.

Small Bread | Single Pies | Small Steak



Slow cook

The heat is emitted evenly from the top and bottom at low temperatures, requiring no lid or additional liquid to be added.

Gentle and slow cooking for a tender result - Pieces of meat



Keep Warm

The grill heating element and the fan switch on and off alternately. The fan circulates the hot air around for crisping the food.

Roasting | Whole Fish | Small cuts of meat | Potatoes



Plate warming

For preheating ovenware.



coolStart function

For the quick preparation of frozen products on level 3. The temperature depends on the cooking instructions. Use the highest temperature specified on the packaging. Preheating is not required.

Ready to eat food - Lasagne | Chicken | Pizzas | Bread rolls



Pizza setting

Heat from the bottom and the back, leave the base crisp and the food well cooked.

Pizza | Pastries | Quiches



Bottom heating

For slow cooking.

Casseroles | Curries

*varioSpeed option available.

*varioSpeed option available.

Cleaning an oven just got easier.

activeClean® automatic self-cleaning: now with pyrolysis proof rails.

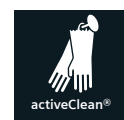

activeClean®

Siemens activeClean® takes care of oven cleaning for you by heating the oven interior to a very high temperature of up to 480°C and turning all residues to ash through a process called 'pyrolysis', the contents are then easily wiped away. So no matter how flamboyant it gets in the oven, you no longer need any chemical treatment to get it clean again – just at the push of a button.



activeClean® solid rails

For even more convenience, selected iQ700 ovens feature pyrolysis ready rails, eliminating the hassle of having to remove interior fittings and washing them by hand.



ecoClean®

Ovens with ecoClean® use specially developed liners to readily absorb grease and fat deposits during the cooking process, keeping them clean on the eye and reducing cooking odours. During the cleaning cycle the oven is heated to approximately 270°C, which allows the liners to break down or oxidise waste deposits, leaving the ecoClean® liners clean and renewed. Being four times more efficient than standard catalytic liners, Siemens ecoClean® provides excellent cleaning performance time after time.



Combination Microwave Oven with pulseSteam

HN678G4S1

60cm Full size Combination Microwave and pulseSteam Oven

Key Highlights

- Steam assisted Cooking
- TFT colour and graphics display with direct touch
- 4D Hot Air
- Vario speed
- Coolstart function
- Softmove door
- Pyrolytic clean

Design & Innovation features

- Steam assistance for 4D Hot Air, top/ bottom heating, Hot air grilling, Keeping warm, Reheating and Dough proving
- Oven capacity: 67 Litre capacity
- 15 heating functions: 4D Hot Air, Bottom heat, Combi microwave variable, Conventional heat, Deep-frozen food special, Dehydrate, fermentation, Full width grill, Half width grill, Hot Air-Eco, Hot Air grilling, Intensive heat, low temperature cooking, Microwave, Pizza setting, pre-heating, Regeneration, warming
- RoastingSensor Plus- enables precision roasting to exact requirements
- BakingSensor
- Rapid heat up option
- 5 shelf positions
- 1 pyrolysis proof telescopic rail
- Enameled cavity
- Sabbath Function
- 5 Microwave power levels
- Cook control plus

Cleaning Features

- activeClean: pyrolytic self cleaning function
- Descaling operating mode

Safety & Quality features

- Residual heat indicator
- Automatic safety switch off
- Cool door with triple glass: keeps the door cool at max 40° C



Dimensions

- Appliance dimensions (HxWxD): 59.5cm x 59.4cm x 54.8cm
- Cutout dimensions (HxWxD): 58.5cm - 59.5cm x 56cm - 56.8cm x 55cm

Technical Information

- Connecting cable: 120cm
- Total connected load: 3.60 kW (16 A plug for connection)
- Heating Temperature: 30°C - 250°C

Integrated Accessories

- 1 x enamel baking tray
- 1 x combination grid
- 1 x universal pan

Optional Accessories

- HZ634080 - Baking and roasting grid (microwave)
- HZ327000 - Baking stone
- HZ631070 - Baking tray, anthracite enameled

Combination Steam Oven

HS636GDS1

60cm Full size Combination Steam Oven

Key Highlights

- 5.7" TFT colour and graphics display with direct touch
- 4D Hot Air
- roastingSensor Plus and PulseSteam
- coolStart function
- softMove door

Design & Innovation features

- Large oven capacity: 71 litres
- Multifunction combination steam oven with 13 cooking functions: 4D Hot Air, Hot Air-Eco, Top/bottom heating, Top/bottom heating Eco, Circulated air grilling, Large area grill, Small area grill, Pizza setting, coolStart function, Bottom heating, Slow cook, Keep warm, Plate warming
- Additional cooking functions: Full steam, Regeneration, Fermentation and Defrost
- Internal glass door
- Stainless steel oven interior
- Oven interior LED light on top
- Integral cooling fan
- Water tank capacity: 1 litre
- Tank empty indicator
- roastingSensor Plus
- PulseSteam: added steam with few cooking functions
- 5 Shelf levels
- Automatic rapid heat function
- softMove door
- Sabbath function
- Energy efficiency A - 30%: 30% less energy consumption than the best energy class A

Cleaning Features

- Drying function
- ecoClean Plus function for back panel
- Descaling programme

Safety & Quality features

- Residual heat indicator
- Childproof lock function
- Automatic safety switch off
- coolDoor with triple glass: keeps the door cool at max. 40°C

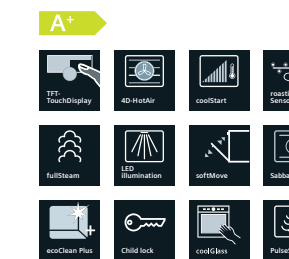

Dimensions

- Appliance dimensions (HxWxD): 59.5cm x 59.5cm x 54.8cm
- Cutout dimensions (HxWxD): 58.5cm - 59.5cm x 56cm - 56.8cm x 55cm

Technical Information

- Connecting cable: 120cm
- Total connected load: 3.60 kW (16 A plug for connection)
- Heating Temperature: 30°C - 250°C

Integrated Accessories

- 1 X Grid
- 1 X Steam container punched (size XL)
- 1 X Steam container punched (size S)
- 1 X Steam container unpunched (size S)
- 1 X Enamel baking tray
- 1 X Universal pan

Optional Accessories

- HZ327000 - Baking Stone
- HZ631070 - Enamelled baking tray

Compact Combination Steam Oven

CS656GBS1

45cm Compact Combination Steam Oven

Key Highlights

- 5.7" TFT colour and graphics display with direct touch
- 4D Hot Air
- PulseSteam: added steam with few cooking functions
- coolStart function
- softMove door

Design & Innovation features

- Oven capacity: 47 litres
- Multifunction combination steam oven with 13 cooking functions: 4D Hot Air, Hot Air-Eco, Top/bot tom heating, Top/bottom heating Eco, Circulated air grilling, Large area grill, Small area grill, Pizza setting, coolStart function, Bottom heating, Slow cook, Keep warm, Plate warming
- Additional cooking functions : Full steam, Regeneration, Fermentation and Defrost
- Internal glass door
- Stainless steel oven interior
- Oven LED interior light on top
- Integral cooling fan
- Water tank capacity: 1 litre
- Tank empty indicator
- softMove door
- 3 Shelf levels
- Automatic rapid heat function
- PulseSteam: added steam with few cooking functions
- Sabbath function
- Energy efficiency A - 20%: 20% less energy consumption than the best energy class A

Cleaning Features

- Drying function
- ecoClean Plus function for back, ceiling and side liners
- Descaling programme



Safety & Quality features

- Residual heat indicator
- Childproof lock function
- Automatic safety switch off
- coolDoor with triple glass: keeps the door cool at max. 40°C

Dimensions

- Appliance dimensions (HxWxD): 45.5cm x 59.5cm x 54.8cm
- Cutout dimensions (HxWxD): 45cm - 45.5cm x 56cm - 56.8cm x 55cm

Technical Information

- Connecting cable: 150cm
- Total connected load: 3.3 kW (16 A plug connection)
- Heating Temperature: 30°C - 250°C

Integrated Accessories

- 1 x Grid
- 1 x Steam container, punched (size XL)
- 1 x Steam container, punched (size S)
- 1 x Steam container, unpunched (size S)
- 1 x Universal pan

Optional Accessories

- HZ327000 - Baking Stone
- HZ631070 - Enamelled baking tray

Combination Microwave Oven

HM676G0S1

60cm Full size Combination Microwave Oven

Key Highlights

- 5.7" TFT colour and graphics display with direct touch
- 4D Hot Air
- varioSpeed
- coolStart function
- softMove door

Design & Innovation features

- Large oven capacity: 67 litres
- Multifunction combination microwave oven with 13 cooking functions: 4D Hot Air, Hot Air-Eco, Top/bot tom heating, Top/bottom heating Eco, Circulated air grilling, Large area grill, Small area grill, Pizza setting, coolStart function, Bottom heating, Slow cook, Keep warm, Plate warming
- Internal glass door
- Anthracite enamel smooth oven interior
- Oven interior LED light on top
- Electronic clock timer: On, Off and Alarm
- Microwave power levels: 900W, 600W, 360W, 180W, 90 W
- varioSpeed achieved from Combi Microwave function
- cookControl Plus : Automatic cooking programmes
- Automatic rapid heating up function
- softMove door
- 5 Shelf levels
- Automatic rapid heat function
- 1-level Telescopic rails: pyrolitic proof
- Sabbath function

Cleaning Features

- activeClean: Pyrolytic self-cleaning function

Safety & Quality features

- Residual heat indicator
- Childproof lock function
- Automatic safety switch off
- Door lock function
- coolDoor with quadruple glass: keeps the door cool at max. 30°C



Dimensions

- Appliance dimensions (HxWxD): 59.5cm x 59.5cm x 54.8cm
- Cutout dimensions (HxWxD): 58.5cm - 59.5cm x 56cm - 56.8cm x 55 cm

Technical Information

- Connecting cable: 120cm
- Total connected load: 3.60 kW (16 A plug connection)
- Heating Temperature: 30°C - 250°C

Integrated Accessories

- 1 x Combination grid
- 1 x Universal pan
- 1 x Enamel baking tray

Optional Accessories

- Baking Stone - HZ327000
- Enamelled baking tray -HZ631070
- Baking and Roasting grid (Microwave) - HZ634080

Compact Combination Microwave Oven

CM676GBS1

45cm Compact Combination Microwave Oven

Key Highlights

- TFT colour and graphics display with direct touch
- 4D Hot air
- varioSpeed
- coolStart function
- softMove door

Design & Innovation features

- Oven capacity: 45 litres
- Multifunction combination microwave oven with 13 cooking functions: 4D hot air, Hot Air-Eco, Top/bottom heating, Top/bottom heating ECO, Circulated air grilling, Large area grill, Small area grill, Pizza setting, coolStart function, Bottom heating, Slow cook, Keep warm, Plate warming
- Internal glass door
- Anthracite enamel smooth oven interior
- Oven interior LED light on top
- Electronic clock timer: On, Off and Alarm
- Microwave power levels: 1000W, 600W, 360W, 180W, 90 W
- varioSpeed achieved from Combi Microwave function
- cookControl Plus : Automatic cooking programmes
- Automatic rapid heating up function
- softMove door
- 3 Shelf levels
- Automatic rapid heat function
- Sabbath function

Cleaning Features

- activeClean: Pyrolytic self-cleaning function

Safety & Quality features

- Residual heat indicator
- Childproof lock function
- Automatic safety switch off
- Door lock function
- coolDoor with quadruple glass: keeps the door cool at max. 30°C



Dimensions

- Appliance dimensions (HxWxD): 45.5cm x 59.5cm x 54.8cm
- Cutout dimensions (HxWxD): 45cm - 45.5cm x 56cm - 56.8cm x 55cm

Technical Information

- Connecting cable: 150cm
- Total connected load: 3.65 kW (16 A plug connection)
- Heating Temperature: 30°C - 250°C

Integrated Accessories

- 1 x Combination grid
- 1 x Universal pan
- 1 x Enamel baking tray

Single Oven

HB676G5S1

60cm Single Oven

Key Highlights

- 5.7" TFT colour and graphics display with direct touch
- 4D Hot Air
- coolStart function
- softMove door
- activeClean: Pyrolytic self-cleaning function

Design & Innovation features

- Large oven capacity: 71 litres
- Multifunction oven with 13 cooking functions: 4D Hot Air, Hot Air-Eco, Top/bottom heating, Top/bottom heating Eco, Circulated air grilling, Large area grill, Small area grill, Pizza setting, coolStart function, Bottom heating, Slow cook, Keep warm, Plate warming
- Internal glass door
- Anthracite enamel smooth oven interior
- Oven interior light on top
- Integral cooling fan
- Grill element: fixed assembled
- Electronic clock timer: on, off and alarm
- softMove door
- 5 Shelf levels
- Automatic rapid heat function
- 3 level telescopic rails: Pyrolytic proof
- Sabbath function
- Energy efficiency A - 20%: 20% less energy consumption than the best energy class A

Cleaning Features

- activeClean: Pyrolytic self-cleaning function

Safety & Quality features

- Residual heat indicator
- Childproof lock function
- Automatic safety switch off
- coolDoor with quadruple glass : keeps the door cool at a max. 30°C



Dimensions

- Appliance dimensions (HxWxD): 59.5cm x 59.5cm x 54.8cm
- Cutout dimensions (HxWxD): 58.5cm - 59.5cm x 56cm - 56.8cm x 55cm

Technical Information

- Connecting cable: 120cm
- Total connected load: 3.60 kW (16 A plug connection)
- Heating Temperature: 30°C - 300°C

Integrated Accessories

- 1 x Enamel baking tray
- 1 x Combination grid
- 1 x Universal pan

Optional Accessories

- HZ327000 - Baking Stone
- HZ631070 - Enamelled baking tray

Single Oven

HB634GBS1

60cm Single Oven

Key Highlights

- TFT display with direct touch
- 4D Hot Air
- coolStart function
- softMove door
- ecoClean function for back panel

Design & Innovation features

- Large oven capacity: 71 litres
- Multifunction oven with 13 cooking functions: 4D Hot Air, Hot Air-Eco, Top/bottom heating, Top/bottom heating Eco, Circulated air grilling, Large area grill, Small area grill, Pizza setting, coolStart function, Bottom heating, Slow cook, Keep warm, Plate warming
- Internal glass door
- Anthracite enamel smooth oven interior
- Oven interior light on top
- Integral cooling fan
- Grill element: fixed assembled
- Electronic clock timer: on, off and alarm
- softMove door
- 5 Shelf levels
- Automatic rapid heat function
- Sabbath function
- Energy efficiency A - 30%: 30% less energy consumption than the best energy class A

Cleaning Features

- ecoClean function for back panel

Safety & Quality features

- Residual heat indicator
- Childproof lock function
- Automatic safety switch off
- coolDoor with triple glass: keeps the door cool at a max. 40°C

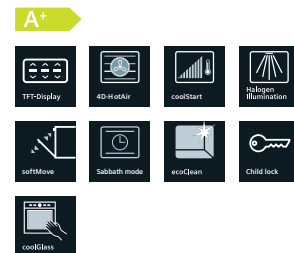

Dimensions

- Appliance dimensions (HxWxD): 59.5cm x 59.5cm x 54.8cm
- Cutout dimensions (HxWxD): 58.5cm - 59.5cm x 56cm - 56.8cm x 55cm

Technical Information

- Connecting cable: 120cm
- Total connected load: 3.60 kW (16 A plug connection)
- Heating Temperature: 30°C - 300°C

Integrated Accessories

- 1 x Enamel baking tray
- 1 x Combination grid
- 1 x Universal pan

Optional Accessories

- HZ617000 - Pizza tray
- HZ327000 - Baking stone
- HZ631070 - Enamelled baking tray
- HZ638270 - 2 Level, full extension telescopic rails

Single Oven

HB23AB523K

60cm Single Oven

Key Highlights

- Large oven capacity: 67 litres
- Multifunction oven with 5 cooking functions
- 3D Hot Air
- ecoClean function for back panel
- White display with blue indicator light

Design & Innovation features

- Large oven capacity: 67 litres
- Multifunction oven with 5 cooking functions: 3D Hot Air, Top/Bottom heating, Circulated air grilling, Large area grill and Bottom heating
- Full glass drop down door
- White display with blue indicator light
- Rotary control dials
- Grey enamel smooth oven interior
- Oven interior light on back upper corner
- Grill element: drop down grill for better access and easy cleaning
- Electronic clock timer: on, off and alarm
- Automatic rapid heat function
- Energy efficiency A - 20%: 20% less energy consumption than the best energy class A

Cleaning Features

- ecoClean function for back panel

Safety & Quality Features

- Childproof lock function
- coolDoor with triple glass: keeps the door cool at max. 40°C



Dimensions

- Appliance dimensions (HxWxD): 59.5cm x 59.5cm x 54.8cm
- Cutout dimensions (HxWxD): 57.5cm - 59.7cm x 56cm x 55cm

Technical Information

- Connecting cable: 95 cm
- Total connected load: 3 kW (16 A plug connection)
- Heating Temperature: 50°C - 270°C

Integrated Accessories



- 1 x Enamel baking tray
- 1 x Combination grid
- 1 x Universal pan

Optional Accessories

- HZ327000 - Baking Stone
- HZ338357 - 3 Level, full extension telescopic rails

Accessories - Ovens & Microwaves

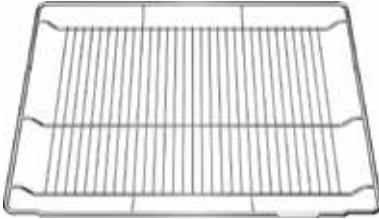
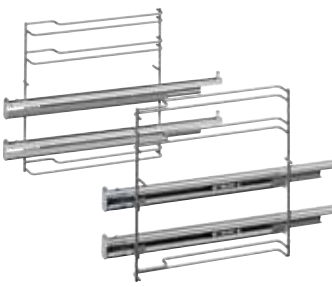
Accessory No.	Image	Name	Accessory for	Description
HZ327000		Baking Stone	HN678G4S1 HS636GDS1 CS656GBS1 HM676G0S1 CM676GBS1 HB676G5S1 HB634GBS1 HB23AB523K	Baking or Pizza stone is a traditional way of baking pizza effectively. This method would ensure crispier crust by absorbing moisture and also ensures the bread is evenly baked/cooked from all the sides without burning it. It is hence ideal for baking bread, unleavened bread, pizza and frozen food dishes.
HZ631070		Enamelled baking tray	HN678G4S1 HS636GDS1 CS656GBS1 HM676G0S1 CM676GBS1 HB676G5S1 HB634GBS1	Suitable for baking cookies and cakes. It enables baking in large quantity in one time. Since the tray is made of high quality adhesive coating, it usually requires no greasing before baking. These trays are resistant to maximum 300 degrees and are also dishwasher proof.

Accessory No.	Image	Name	Accessory for	Description
HZ634080		Baking and Roasting grid (Microwave)	HN678G4S1 HM676G0S1 CM676GBS1	Baking and roasting grid is used to place heavy objects or food item. This grid is also suitable to keep ovenware, cake tins and ovenproof dishes along with comfortable roasting and grilling food of any type.
HZ638270		2 Level, full extension telescopic rails	HB634GBS1	The 2-fold telescopic extension rails allow you to pull out baking trays, wire shelves or the universal pan at two levels. It ensures no tilting, as the pull out device is mounted into the back of the oven in a safe and stable manner. It is hence useful when you have heavy food items kept inside the oven. These rails are also pyrolytic proof and fully compatible with Ovens and Combi Microwave Ovens.
HZ338357		3 Level, full extension telescopic rails	HB23AB523K	The 3-fold telescopic extension rails allow you to pull out baking trays, wire shelves or the universal pan at three levels. It ensures no tilting, as the pull out device is mounted into the back of the oven in a safe and stable manner. It is hence useful when you have heavy food items kept inside the oven.

Microwaves

Enjoy more space with built-in
Microwaves in your kitchen.

Siemens offers variety of built-in microwave ovens to clear the working area and give you more space. We offer three different design options in our microwave – Full size Combination Microwave oven, a 45cm Compact Combination Microwave oven and Solo Microwave ovens designed to be built into a wall cabinet placed above a single oven perfectly.

The speed and convenience of the microwave has made it a must-have in most Indian kitchens. Siemens also offers a range of state-of-the-art microwaves - with a grill and without, with five power levels, electronic control, automatic weight defrost, and cooking programmes.



Built-in Microwaves that define seamless kitchen.

Seamless design

There are three different design options in our microwave – Full size Combination Microwave oven, a 45cm Compact Combination Microwave oven and Solo Microwave ovens designed to be built into a wall cabinet placed above a single oven perfectly. The Microwaves are incorporated with sophisticated feature like Innwave technology, which means improved efficiency and energy savings of up to 15% over traditional microwave technology.

Automatic Door Opening

This function is available only when you activate it. You can also manually open the appliance door, even in the event of a power cut.

Grilling Function

3 stage grill gives a perfect grill temperature control. It is ideal for smaller quantities.



TFT-Display

TFT Display

It has never been this easy to keep an eye on everything. Thanks to the menu structure, which is optimized for convenient and easy-to-use touch navigation, the new TFT display is the most innovative and intuitive user interface available for a microwave oven. Designed to serve one purpose: giving you full control.



LED light

Illumination - LED lights

The lateral long-life LED lights illuminate the microwave evenly from all sides, so you can see your dishes in a realistic light. When you open the appliance door, the interior lighting switches on. If the door remains open for longer than five minutes, the cooking compartment lighting switches off again. For all operating modes, the cooking compartment lighting switches on and off automatically, at the start and end of any operation.



Microwave cooking functions

Defrosting

- **Bread:**
Whole, round or long bread | Sliced bread |
Sponge cake, Yeast cake, Fruit flan cakes
without icing | Cream or Gelatine
- **Meat:**
Joints, flat pieces of meat | Minced meat | Chicken |
Duck
- **Fish:**
Whole fish | Fish fillet | Fish cutlet

- **Potatoes:**
Boiled potatoes | Unpeeled boiled potatoes |
Chopped potatoes of the same size
- **Rice:**
All types of rice
- **Baked potatoes:**
Waxy potatoes | Predominantly waxy potatoes
or floury potatoes approx. 6 cm thick

Cooking

- **Fresh vegetables:**
Cauliflower | Broccoli | Carrots | Spring onions |
Peppers | Zucchini
- **Frozen vegetables:**
Cauliflower | Broccoli | Carrots | Turnip |
Red cabbage | Spinach
- **Grilling:**
Paneer | Chicken | Fish | Prawns | Marshmallows |
Peppers | Zucchini | Onions | Corn | Cherry Tomatoes

Combination mode

- **Frozen lasagne:**
Lasagne | Bolognese
- **Chicken portions:**
Chicken thigh | Half chicken

And many more...

Microwave

BE634LGS1I

38cm Microwave Oven with Grill

Key Highlights

- TFT display with direct touch
- Grill function
- cookControl: 10 automatic cooking programmes
- Oven interior LED light
- Stainless steel oven interior

Design & Innovation features

- Microwave Oven capacity: 21 litres
- cookControl: 10 automatic cooking programmes
- Microwave oven with 2 cooking functions: Microwave and Grilling
- Microwave power levels: 900W, 600W, 360W, 180W, 90W
- Combination of Grill and Microwave power levels: 360W / 180W / 90W
- Stainless steel oven interior
- Oven interior LED light
- Automatic door opening

Dimensions

- Appliance dimensions (HxWxD): 38.2cm x 59.4cm x 31.8cm
- Cutout dimensions (HxWxD): 36.2cm - 38.2cm x 56cm - 56.8cm x 30cm

Technical Information

- Connecting cable: 200 cm
- Total connected load: 1.99 kW (16 A plug connection)

Integrated Accessories

- 1 x Glass pan
- 1 x Grid



Microwave

BF634LGS1I

38cm Microwave Oven

Key Highlights

- TFT display with direct touch
- cookControl: 7 automatic cooking
- Oven interior LED light
- Stainless steel oven interior
- Automatic door opening

Design & Innovation features

- Microwave Oven capacity: 21 litres
- cookControl: 7 automatic cooking programmes
- Microwave power levels: 900W, 600W, 360W, 180W, 90W
- Stainless steel oven interior
- Oven interior LED light
- Automatic door opening

Dimensions

- Appliance dimensions (HxWxD): 38.2cm x 59.4cm x 31.8cm
- Cutout dimensions (HxWxD): 36.2cm - 38.2cm x 56cm - 56.8cm x 30cm

Technical Information

- Connecting cable: 200 cm
- Total connected load: 1.22 kW (16 A plug connection)



Microwave

HF22G564IN

38cm Microwave Oven with Grill

Key Highlights

- Microwave Oven capacity: 25 litres
- Microwave oven with 2 cooking functions: Microwave and Grilling
- Glass turntable diameter: 31.5cm
- Timer
- Centred glass left hinged door

Design & Innovation features

- Microwave Oven capacity: 25 litres
- Centred glass left hinged door
- Rotary control dial
- Microwave oven with 2 cooking functions: Microwave and Grilling
- Microwave power levels: 900W, 600W, 360W, 180W, 90W
- Combination of Grill and Microwave power levels: 360W / 180W / 90W
- Stainless steel oven interior
- Oven interior light at right side
- Glass turntable diameter: 31.5cm
- Timer

Dimensions

- Appliance dimensions (HxWxD): 38.2cm x 59.4cm x 38.8cm
- Cutout dimensions (HxWxD): 38cm x 56cm x 55cm

Technical Information

- Connecting cable: 200cm
- Total connected load: 1.45 kW (16 A plug connection)



Hobs

The most stylish and powerful range of Hobs.

Introducing the Siemens powerful range of hobs, where superior, eye-catching design sensibilities and razor sharp looks come together with innovative technology and ergonomic designs. So whether you choose the cutting-edge innovation of flexInduction cooking, or a more traditional gas hob with a contemporary twist, all of our hobs are designed to co-ordinate beautifully with your other range appliances.





Gas Hobs

Here's one thing you can be sure of:
groundbreaking precision.

If you've ever had trouble achieving the flame level and cooking results you want, the stepFlame Technology from Siemens gas cooktops is set to change things. Offering revolutionary precision that gives you full control of heat quickly, you will enjoy the freedom to experiment and whip up your next signature dish. Experience confidence in the kitchen like never before with the new Siemens Gas Cooktops.

stepFlame Technology: Turn up the heat exactly the way you want it.

Nine precise levels for ultimate flame control, thanks to stepFlame Technology.



No more bending to check the power of your flame, no more hoping that it is at the right heat level. From now on, you'll get exactly the heat and the flame you need when you cook with stepFlame Technology. It is as easy and quick to operate as it sounds: simply turn the knob to the precisely defined level of heat you want. Your dinner parties will never be the same again. For more information about stepFlame Technology and our range of Siemens Gas Cooktops, go to siemens-home.com/stepFlame



Redesigned for the modern kitchen.

Our new cooktops have been completely redesigned to elevate your cooking. From advanced functions for precise results to our sturdy control knobs perfectly paired with premium cast iron pan supports in an elegant design, your palate and eyes will be pleased in equal measure.



Expand your possibilities with the dualWok Burner.

The dualWok Burner allows for more flexibility in the kitchen - keep meals warm or prepare a wide variety of dishes, even in large quantities. With its powerful inner and outer burner rings, you will always get the desired results.



Unmatched Power. Extremely Efficient.

The Siemens gas hob range is all about powerful and efficient cooking, ergonomic design, and configuration options that meet individual needs. Whether you prefer high-quality stainless steel or beautiful and durable ceramic glass, the Siemens gas hob range will have a clean and contemporary look which coordinates seamlessly with the rest of your Siemens Domino and Induction hob range. Our gas hobs are equipped with the latest high-speed wok burner technology. The top-of-the-range models feature beautiful and durable black ceramic glass hob bases, with dishwasher safe cast iron pan supports that provide both a strong contemporary look and a stable base for any size of pan. So whether your preference is for classic high quality stainless steel, or for a modern, on glass model, Siemens will always have a hob that's perfect for you and just right for your kitchen.

With our gas hobs, cooking is a sheer pleasure.



Ideal Design

- Designed with more space between the burners, they are suited for cooking in bigger, medium or small pots
- The silver colored high quality round knobs are crafted for comfortable handling
- Wok burners are placed in comfortable positions for easy access
- Simply designed heavy and high quality cast iron pan supports for easy cleaning and handling



For safest cooking experience

For complete peace of mind, all Siemens gas hobs feature a Flame Failure Device, which cuts-off the supply of gas to the individual burner, should the flame be accidentally extinguished, somehow. This ensures that no gas leakage can ever happen, and is applicable for all Siemens gas hobs and burners.



Easy One Hand Ignition

All Siemens gas hob control knobs are designed seamlessly with superior quality material and are easy to operate. The gas hobs can be ignited with one hand via the control dials. Simply push and turn, wait for a few seconds, then release – no separate ignition buttons necessary.

Bring more power and speed to your cooking.



Powerful, Precise Wok Cooking

Siemens gas hobs meet the increasing demand for high speed cooking, with wok burners delivering up to 6kW of power. But power is nothing without precision. These hobs can be turned down to just 0.3kW – perfect for simmering or melting chocolate. For the ultimate in flexibility, our wok burners are dual control – the inner and outer flame rings can be adjusted from the same control dial.



Strong and High Quality Cast Iron Pan Supports

Our cast iron pan supports are both stylish and highly durable, providing robust support for even the heaviest pans, and are also fitted with rubber feet to prevent scratching making them ideal for Indian cooking style and for pots or woks. For convenient cleaning, Siemens pan supports are treated with a patented coating, which resists discoloration during the dishwashing cycle as few high end models are featured with dishwasher safe pan supports.

Induction Hobs

Speed. Energy-efficiency.
Style.

Induction cooking is recognised as being one of the quickest, safest and most efficient methods of cooking available. Our traditional induction hob range feature automatic pan recognition ensures that the hob starts operating only when the sensor recognises the pan. Induction cooking is quicker than gas and much more energy efficient, allowing you to enjoy speedy food whilst being kinder to the environment. Induction hobs are perfect for a wide variety of cooking and yet making your kitchen truly bespoke.



Fast to cook, safe to use.



Faster cooking made quicker: PowerBoost function

Power boost increases the power output of selected zones by 50%, allowing precision heat when you need it most – perfect when time is of the essence.

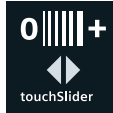

Control at your fingertips: Innovative touchSlider

Unique to Siemens, glide your finger gently over the control panel to select the appropriate power level. This sophisticated pressure technology never fails to deliver even when your hands are too hot, cold or even when caked with ingredients.



Wipe protection function

Cleaning the control panel while the hob is on, may change the settings. In order to avoid this, the hob has a wipe protection function. By pressing this, the control panel is locked for 35 seconds and the surface of the control panel can now be cleaned without risk of changing the settings.

Automatic pan recognition

Energy-efficiency is at the heart of Siemens products, and is at the heart of automatic pan recognition. Only the area of the hob in contact with the pan receives energy, meaning energy isn't wasted by heating the entire unit which means not only will this lower your carbon footprint, but it will also reduce your utility bills.

Better energy efficiency

Now you can save energy by reducing wastage, because only areas of the Induction cook surface that are in contact with the cookware are active at any particular time.

Better heat distribution

Cook your dishes evenly with the innovative elongated shaped induction coils. Even heat distribution ensures that there are no 'cool spots' where the pan is not over an induction coil.

Easier to clean, and safer to use

The ceramic glass is warmed only by the heat transferred to the cookware and its contents. Due to this, spillages are less likely to burn and there is normally no need to wait for the glass to cool down before simply wiping it over with a cloth. And if you turn on an induction hob without having a pot or pan on it, there is zero risk of burning yourself because the hob itself doesn't heat up at all.



flexInduction Hobs

Liberate your pans from restrictive cooking zones, with flexInduction.

Siemens flexInduction hobs can behave as traditional induction hobs with four or five separate zones. But choose to link the zones together to form one or more rectangular surfaces, and the real magic begins. The extended cooking surface can accommodate pans of any size, and even several pans placed anywhere on the surface at the same time. And of course flexInduction has all the advantages of induction cooking, including boost settings, pan recognition and a power output of up to 3.6kW. Each flexInduction zone uses four innovative elongated oval inductors beneath the glass, each of which can act independently to sense the presence of cookware on the hob. Individual inductors will work only if cookware is detected, ensuring efficient operation whether a 10cm diameter milk pan is placed in one corner, or a large griddle plate covers the whole zone.



flexInduction hobs that think for you.



Greater flexibility with flexInduction Plus

The hob has a flexInduction Plus cooking zone which is located between the two flexible cooking zones and which switches on in conjunction with the right- or left-hand flexible cooking zone. This function enables flexible expansion of the induction hob for pots and pans with a diameter of up to 30 cm.

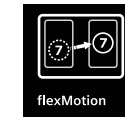

Liberate your cooking from a single cooking zone: flexMotion

Allows intuitive control power levels only by moving pots - three temperature zones. Do not leave anything behind when you move something. That's exactly what the new flexMotion function is all about. When the pan from one to the other cooking zone is moved, the flexInduction hob Plus takes the selected power mode automatically to the new hotplate. The user only needs to confirm this position. Simultaneously, the hob automatically switches the original cooking area of the roof.



Choose your heating zone: powerMove Plus

This function offers a totally new experience. Divide your hob into 3 heating zones with the powerMove Plus feature. From frying at the front to warming at the back of your hob, just lift your cookware to the right spot to activate the correct heating zone. The rear zone automatically detects and starts with the minimum level 1 to keep the food warm.



No more scorching: fryingSensor Plus

It's nice to have some help with your frying for a controlled frying temperature, simply choose from a range of automatic programs according to the type of food being cooked, and fryingSensor Plus will apply the ideal setting. A signal tone will let you know when the ideal frying temperature has been reached, and since the pan's temperature is monitored for the entire frying process, it spares you the trouble of making manual adjustments.



One step ahead: quickStart

When you turn on the flexInduction hob, the quickStart function automatically identifies and selects the cooking area on which you have placed the pot. All you have to do is adjust the temperature setting, and you're ready to go.

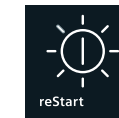

Start again with original settings: reStart

In case the flexInduction hob automatically turns itself off, say because of spilled liquid on the user interface, the reStart function lets you return to your selected settings simply by tapping on the power button within four seconds of the hob switching off.

More power. More precision.



Control at your fingertips : Innovative touchSlider control

The stylish and ergonomic touchSlider allows you to simply slide your finger across the temperature scale to the desired settings. You can also touch the desired level directly for faster adjustments to the cooking zone temperature.



Cooking was never easier: dual lightSlider control

The Dual lightSlider allows you to intuitively operate your FlexInduction hob. Cooking was never easier. One touch is all it takes. This hob comes with the Dual lightSlider. Requiring only the lightest of touches, this sophisticated pressure technology never fails to deliver.

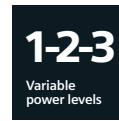

Precision in cooking: Variable power levels

All induction models feature a variable 17-stage electronic temperature display that offers you precise control over your cooking, from a low simmer to a rapid boil.

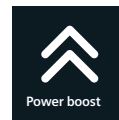

Extra power when you need it: Power Boost

The boost function increases the power output of the selected zone by approximately 50% and this it does by 'borrowing' power from its partner cooking zone.



Convenient extras.



Stay spill-free: wipeProtection

When cooking with passion leads to a spill or two, simply activate wipeProtection, which will freeze settings for approximately 35 seconds. This provides enough time to clean up any accidental spills, without affecting any program settings.

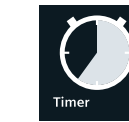

Cooking Timer with Automatic switch off

The timer function can be used in two ways: as an independent timer (that sounds a signal at the end of the cooking time) or to automatically switch-off the cooking zone at the end of your desired cooking time. Most Siemens hobs are equipped with a timer with dual usage.



2 Stage Residual Heat Indicators

After a pan is removed, residual heat will remain for a short period. An LED display will show 'H' when a zone is above 95°C - suitable for finishing off cooking or keeping food warm. A small 'h' indicates a temperature of 65-85°C as a safety precaution.



Automatic safety switch-off

Built-in sensors identify when the flexInduction hob is no longer in use, and will automatically shut it down, so there's no need to worry if you've forgotten to turn it off.



Childproof lock function

In case you have a child around the hob or have some urgent work to attend to, lock the controls by simply using the Child-proof Lock button on the control panel. The lock can be re-activated simply. It's now easy to prevent inadvertent accidents.



Domino Hobs Cook your own way.

Siemens modular domino hobs can be mixed and matched smoothly with other 30cm dominos and full size hobs ranging from 40 – 90cm to create a hob, perfectly tailored to your needs. For example, you could mix ceramic induction cooking zones with a gas wok burner. You could even include a Teppanyaki domino hob – perfect for low fat stir-fry veggies!



A serve of Japanese influence: Teppanyaki

Now you can prepare authentic Japanese dishes in the comfort of your own kitchen. The high-quality steel surface not only delivers that unmistakable Japanese flavour, it provides the perfect canvas for creating light and healthy dishes. Featuring touchSlider controls and a ceramic glass cover for when not in use, the Siemens Teppanyaki makes a serious statement in any cooking enthusiast's kitchen.



Modern way of frying, yet healthy: Deep Fryer

The modern Domino deep fryer for crispy fritters, Samosa, french fries, Medu wada etc. fish, meat, vegetables and baked goods. The large, high-quality stainless-steel container holds up to 4 litres of deep-frying oil. This domino ensures even browning, crispy, fully baked and a healthy snack which is controlled by an easy touchSlider. When not in use, a black ceramic glass cover conceals the grill to provide a seamless finish.

Design continuity

The connecting feature of all domino hobs is the elegant appearance of the faceted glass surface at the front of each unit. Extremely robust and easy to clean, it is used on all domino modules to ensure you achieve a clean and continuous line, while elegant stainless steel side profiles provide a beautifully finished frame.



The taste of the great outdoors, inside: BBQ Grill

The Siemens BBQ Grill brings succulent flavours right into your kitchen. Comprising a stainless steel trough, lava stones for grease absorption, and a premium cast iron grill, this domino opens up a new range of techniques and cooking styles, all controlled with precision using the tactile touchSlider control. When not in use, a black ceramic glass cover conceals the grill to provide a seamless finish.

For even more flexibility while cooking: Special FlexInduction Hob accessories

To provide an even greater degree of flexibility when preparing dishes, Siemens offers you three special items as special accessories for flexInduction hobs. Whilst, grill platter ensures the greatest enjoyment of barbecue style food without charcoal or irritating smoke, you can cook a variety of low-fat and vitamin- rich dishes using the small and large teppanyaki trays.

Teppanyaki – Heating extremely quickly the Teppanyaki is great for fast Japanese cooking. Perfect for a cooked breakfast or a healthy stir-fry. The pan comes in two sizes that fit across either three or four flexInductors.

Available in 2 sizes:
Accessory code: HZ390512 (40x20cm), HZ390511 (30x20cm)



Griddle plate – Specially designed to use across four flexInductors. The grilling pan maintains an even heat which is perfect for frying chicken, fish or veggies.

Accessory code: HZ390522.



For professional look and safety: special accessory for Domino range – Connecting strip

The domino hobs are combined to make up what is essentially a large hob with different types of heat source. A joining strip is normally used to join the hobs together, which is a much neater looking and easier to clean installation. Also, it protects from water seeping inside and maintains the heat level of individual hobs as they are placed closed to each other. The connecting strip helps to balance height difference between two hobs of upto 2mm. The strip is not visible after installation yet helps the aesthetic to look seamless. The strip works for all kinds of work top material.

Connecting strip
Accessory code: HZ394301



Gas Hobs

Gas Hob

ER9A6SD70
90 cm, Gas hob with integrated controls, Ceramic

Key Highlights

- StepFlame Technology
- Sword Control Knobs
- One Handed Ignition via control Knobs
- 5 Gas burners, Dual wok burner, Left: Wok burner 6 KW
- Special flat burner design
- Cast iron continuous pan supports



Design & Innovation features

- StepFlame Technology: precise heat control with nine different flame steps.
- The 7-segment display informs about the chosen power level.
- The dual wok burner with dual flame system and 6 kW of power is ideal for a wide variety of foods, even in large quantities.
- 1 rapid, 2 standard, 1 economy, 1 Dual Wok burner
- Dishwasher proof pan supports are extremely easy to remove and clean in the dishwasher.
- High-quality materials and workmanship - continuous cast-iron pan supports.

Safety & Quality features

- Flame Failure Safety Device



Dimensions

- Appliance dimensions (HxWxD): 4.5cm x 91.5cm x 52cm
- Cut Out Dimensions (HxWxD): 4.5cm x 85-85.2cm x 49-52cm

Technical Information

- Connecting cable: 150
- Total connected gas load: 13.7 KW
- Right rear: Rapid burner 2.8 KW
- Left: Wok burner 6 KW
- Center rear: Economy burner 1.1 KW
- Center front: Standard burner 1.9 KW
- Right front: Standard burner 1.9 KW
- Liquid gas nozzles (28-30/37mbar) included

Included accessories

- 1 x WOK attachment ring

Optional accessories

- HZ298114 Small pot support
- HZ298105 Simmer plate

Gas Hob

EC9A5SB90
90 cm, Gas hob with integrated controls, Stainless steel

Key Highlights

- Step Flame Technology
- Sword Control Knobs
- One Handed Ignition via control Knobs
- 5 Gas burners
- Dual wok burner, Left: Wok burner 5 KW
- Cast iron continuous pan supports



Design & Innovation features

- StepFlame Technology: precise heat control with nine different flame steps.
- The dual wok burner with dual flame system and 5 kW of power is ideal for a wide variety of foods, even in large quantities.
- 1 rapid, 2 standard, 1 economy, 1 Dual Wok burner
- High-quality materials and workmanship – continuous cast-iron pan supports.
- Comfortable usage due to high quality sword knobs.
- A Siemens hob with a uniquely beautiful stainless-steel surface design.

Safety & Quality features

- Flame Failure Safety Device



Dimensions

- Appliance dimensions (HxWxD): 4.5cm x 91.5cm x 52cm
- Cut Out Dimensions (HxWxD): 4.5cm x 80.5 -85.2cm x 49-50.2cm

Technical Information

- Connecting cable: 150 cm
- Total connected gas load: 12.5 KW
- Right rear: Rapid burner 3 KW
- Left: Wok burner 5 KW
- Center rear: Standard burner 1.75 KW
- Center front: Economy burner 1 KW
- Right front: Standard burner 1.75 KW
- Liquid gas nozzles (28-30/37mbar) included

Optional Accessories

- HZ298105 Simmer plate
- HZ241110 Small pot support
- HZ233540 Wok ring
- HZ211310 Simmer cap

Gas Hob

EP9A6QB90

90 cm, Gas hob with integrated controls, Hard Glass, Black

Key Highlights

- Step Flame Technology
- Tempered glass Black
- For a flush or slightly raised built-in solution.
- Sword Control Knobs
- One Handed Ignition via control Knobs
- 5 Gas burners, center: Wok burner 4 KW
- Cast iron continuous pan supports



Design & Innovation features

- StepFlame Technology: precise heat control with nine different flame steps.
- This wok burner with 4.0 kW of power is ideal for a wide variety of foods, even in large quantities.
- Siemens top sheet design for a flush or slightly raised built-in solution.
- Extremely heat-resistant and easy to clean – the modern glass tempered surface.
- High-quality materials and workmanship – continuous cast-iron pan supports.
- 1 rapid, 2 standard, 1 economy, 1 wok burner
- Easy to clean Tempered glass surface.



Safety & Quality features

- Flame Failure Safety Device

Dimensions

- Appliance dimensions (HxWxD): 4.5cm x 91.5cm x 52cm
- Cut Out Dimensions (HxWxD): 4.5cm x 80.5-85.2cm x 49.0-50.2cm

Technical Information

- Connecting cable: 150 cm
- Total connected gas load: 11.5 KW
- Left rear: Standard burner 1.75 KW
- Right rear: Rapid burner 3 KW
- Center: Wok burner 4 KW
- Left front: Economy burner 1 KW
- Right front: Standard burner 1.75 KW
- Liquid gas nozzles (28-30/37mbar) included

Optional accessories

- HZ298114 Small pot support
- HZ298105 Simmer plate

Gas Hob

EC9A5RB90

90 cm, Gas hob with integrated controls, Stainless steel

Key Highlights

- Step Flame Technology
- Sword Control Knobs
- One Handed Ignition via control Knobs
- 5 Gas burners
- Dual wok burner, Center: Wok burner 5 KW
- Cast iron continuous pan supports



Design & Innovation features

- StepFlame Technology: precise heat control with nine different flame steps.
- The dual wok burner with dual flame system and 5 kW of power is ideal for a wide variety of foods, even in large quantities.
- High-quality materials and workmanship - continuous cast-iron pan supports.
- Comfortable usage due to high quality sword knobs.
- A Siemens hob with a uniquely beautiful stainless-steel surface design.
- 1 rapid, 2 standard, 1 economy, 1 Wok burner

Safety & Quality features

- Flame Failure Safety Device

Dimensions

- Appliance dimensions (HxWxD): 4.5cm x 91.5cm x 52cm
- Cut Out Dimensions (HxWxD): 4.5cm x 80.5 -85.2cm x 49-50.2cm

Technical Information

- Connecting cable: 150 cm
- Total connected gas load: 12.5 KW
- Left rear: Standard burner 1.75 KW
- Right rear: Rapid burner 3 KW
- Center: Wok burner 5 KW
- Left front: Economy burner 1 KW
- Right front: Standard burner 1.75 KW
- Liquid gas nozzles (28-30/37mbar) included

Optional Accessories

- HZ298107 Wok ring
- HZ298105 Simmer plate



Gas Hob

EP6A6HB20

60 cm, Gas hob with integrated controls, Hard Glass, Black

Key Highlights

- Step Flame Technology
- Sword Control Knobs
- One Handed Ignition via control Knobs
- 4 Gas burners, Right rear: Wok burner 3.5 KW
- Tempered glass Black
- Cast iron single pan supports
- For a flush or slightly raised built-in solution



Design & Innovation features

- StepFlame Technology: precise heat control with nine different flame steps.
- This wok burner with 3.5 kW of power is ideal for a wide variety of foods, even in large quantities.
- Siemens top sheet design for a flush or slightly raised built-in solution.
- Extremely heat-resistant and easy to clean – the modern glass ceramic surface.
- High-quality materials and workmanship – individual cast-iron pan supports.
- 1 rapid, 1 standard, 1 economy, 1 wok burner



Safety & Quality features

- Flame Failure Safety Device

Dimensions

- Appliance dimensions (HxWxD): 4.5cm x 59cm x 52cm
- Cut Out Dimensions (HxWxD): 4.5cm x 56-56.2cm x 48-49.2cm

Technical Information

- Connecting cable: 100 cm
- Total connected gas load: 8 KW
- Left rear: Standard burner 1.75 KW
- Right rear: Wok burner 3.5 KW
- Left front: Standard burner 1.75 KW
- Right front: Economy burner 1 KW
- Liquid gas nozzles (28-30/37mbar) included

Optional accessories

- HZ298114 Small pot support
- HZ298108 Wok ring
- HZ298105 Simmer plate

Gas Hob

EC6A5HB90

60 cm, Gas hob with integrated controls, Stainless steel

Key Highlights

- Step Flame Technology
- Sword Control Knobs
- 4 Gas burners; Right Rear: Wok Burner 3.5 KW
- Cast iron continuous pan supports
- Stainless steel top sheet



Design & Innovation features

- StepFlame Technology: precise heat control with nine different flame steps
- This wok burner with 3.5 kW of power is ideal for a wide variety of foods, even in large quantities
- High-quality materials and workmanship – continuous cast-iron pan supports
- Comfortable usage due to high quality sword knobs
- A Siemens hob with a uniquely beautiful stainless-steel surface design
- 1 rapid, 1 standard, 1 economy, 1 wok burner

Safety & Quality features

- Flame Failure Safety Device

Dimensions

- Appliance dimensions (HxWxD): 4.5cm x 58.2 x 52cm
- Cut Out Dimensions (HxWxD): 4.5cm x 56-56.2cm x 48-49.2cm

Technical Information

- Connecting cable: 100 cm
- Total connected gas load: 8 KW
- Left rear: Standard burner 1.75 KW
- Right rear: Wok burner 3.5 KW
- Left front: Standard burner 1.75 KW
- Right front: Economy burner 1 KW
- Liquid gas nozzles (28-30/37mbar) included

Included accessories

- 1 x WOK attachment ring

Optional Accessories

- HZ298105 Simmer plate



Gas Hob

ER95331IN

90cm Ceramic Glass Gas Hob

Key Highlights

- Two wok burners on either sides: 4kW
- 3 burners hob
- Strong matt enamel pan supports
- Flame failure safety device
- Tempered glass gas hob

Design & Innovation features

- 3 burners hob
- High flame wok burners at extreme sides
- Front mounted control knobs
- Wok burner at left side: 4 kW
- Wok burner at right side: 4 kW
- Standard burner at centre: 1.7 kW
- Timer#
- Flame indicator
- Single handed auto ignition
- Strong matt enamel pan supports

Safety & Quality features

- Flame failure safety device

Dimensions

- Appliance Dimensions (HxWxD): 7.7cm x 92cm x 50cm
- Cutout dimensions (HxWxD): 7.6cm x 88cm x 45.5cm

Technical Information

- Connecting cable: 120cm
- Total connected gas load: 9.7 kW
- Left and right Burners: 4 kW
- Standard Burner at Rear Centre: 1.7 kW
- Nozzle presetting/main jet: Liquid gas G30/31, 28-30/37 mbar

Integrated accessories

- 1 x Wok ring
- 1 x Cross support for espresso

#Gas hob having timer function will work only when there is power supply.
*Appliance Dimensions: Height is considered from base of the hob to the pan support.
*Cutout Dimensions: Height is considered from the nozzle to base of the hob.
Please check the drawing for further clarity.



Gas Hob

EC845IB90E

76cm Stainless Steel Gas Hob

Key Highlights

- Wok burner on left: 4 kW
- 4 burners hob
- Strong cast iron pan supports
- Flame failure safety device
- Stainless steel Gas hob

Design & Innovation features

- 4 burners hob
- High flame wok burner on left side
- Front mounted control knobs
- Wok burner on left: 4 kW
- Economy burner at centre front: 1 kW
- Standard burner at centre rear: 1.7 kW
- High-speed burner at right: 3 kW
- Single handed auto ignition
- Strong cast iron pan supports

Safety & Quality features

- Flame failure safety device

Dimensions

- Appliance dimensions (HxWxD): 5.4cm x 76.2cm x 52cm
- Cutout dimensions (HxWxD): 5cm x 56cm x 48cm - 49cm

Technical Information

- Connecting cable: 100cm
- Total connected gas load: 9.7 kW
- Left: Wok Burner 4 kW • Front Centre: Economy Burner 1 kW
- Rear Centre: 1.7 kW • Right: High speed Burner 3 kW
- Nozzle presetting/main jet: Natural gas H/E 20 mbar, E+ 20/25 mbar
- Nozzle set enclosed: Liquid gas G30/31, 28-30/37 mbar

Optional Accessories

- HZ298114 - Small pot support
- HZ298105 - Simmer plate
- HZ298107 - Wok ring

*Appliance Dimensions: Height is considered from base of the hob to the pan support.
*Cutout Dimensions: Height is considered from the nozzle to base of the hob.
Please check the drawing for further clarity.



Gas Hob

ER3A6BD70

30 cm, Gas hob with integrated controls, Ceramic

Key Highlights

- Step Flame Technology
- 7-segment display
- Sword Control Knobs
- Ceramic top sheet
- 2 Gas burners
- Special flat burner design
- Can be combined with Domino ceramic hobs
- Pan supports dishwasher proof

Design & Innovation features

- StepFlame Technology: precise heat control with nine different flame steps
- The 7-segment display informs about the chosen power level
- Dishwasher proof pan supports are extremely easy to remove and clean in the dishwasher
- High-quality materials and workmanship – continuous cast-iron pan supports
- Comfortable usage due to high quality sword knobs
- 1 rapid, 1 standard burner

Safety & Quality features

- Flame Failure Safety Device
- Residual heat indicator

Dimensions

- Appliance dimensions (HxWxD): 4.5cm x 30.2cm x 52cm
- Cut Out Dimensions (HxWxD): 4.5cm x 27cm x 49-50cm

Technical Information

- Connecting cable: 100 cm
- Total connected gas load: 4.7KW
- Center rear: Rapid burner 2.8 KW
- Center front: Standard burner 1.9 KW
- Liquid gas nozzles (28-30/37mbar) included

Included accessories

- 1 x WOK attachment ring

Optional accessories

- HZ394301 Connecting strip
- HZ298113 Small pot support
- HZ298105 Simmer plate



Gas Hob

ER3A6AD70

30 cm, Gas hob with integrated controls, Ceramic

Key Highlights

- Step Flame Technology
- 7-segment display
- Sword Control Knobs
- Ceramic top sheet
- Special flat burner design
- Dual wok burner, Center: Wok burner 6 KW
- Can be combined with Domino ceramic hobs.
- Pan supports dishwasher proof

Design & Innovation features

- StepFlame Technology: precise heat control with nine different flame steps.
- The 7-segment display informs about the chosen power level.
- The dual wok burner with dual flame system and 6 kW of power is ideal for a wide variety of foods, even in large quantities.
- Dishwasher proof pan supports are extremely easy to remove and clean in the dishwasher.
- High-quality materials and workmanship – continuous cast-iron pan supports.

Safety & Quality features

- Flame Failure Safety Device
- Residual heat indicator

Dimensions

- Appliance dimensions (HxWxD): 4.5cm x 30.2cm x 52cm
- Cut Out Dimensions (HxWxD): 4.5cm x 27cm x 49-50cm

Technical Information

- Connecting cable: 100 cm
- Total connected gas load: 6 KW
- Center: Wok burner 6 KW
- Liquid gas nozzles (28-30/37mbar) included

Included accessories

- 1 x WOK attachment ring

Optional Accessories

- HZ394301 Connecting strip
- HZ298113 Small pot support
- HZ298105 Simmer plate



Domino Barbecue Grill

ET375FUB1E
30cm Barbecue Grill

Key Highlights

- Stainless steel design
- touchSlider
- reStart function
- 17 power levels
- Automatic safety switch off

Design & Innovation features

- Cast iron grill
- Black ceramic cover for covering while not being used
- Basin capacity: 2.5 litres
- Removable cast iron grill for easy cleaning
- To be used with water or lava stones
- Oil drainage outlet
- Timer

Safety & Quality features

- Two stage residual heat indicator
- Heat up indicator
- Automatic safety switch off
- Childproof lock function

Dimensions

- Appliance dimensions (HxWxD): 10.8cm x 30.2cm x 52cm
- Cutout dimensions (HxWxD): 12.8cm x 27cm x 49cm - 50cm

Technical Information

- Connecting cable: 100cm
- Total connected load: 2.4 kW

Integrated Accessories

- Lava stones, 3kg

Optional Accessories

- HZ398300 - Lava stones
- HZ394301 - Connecting strip

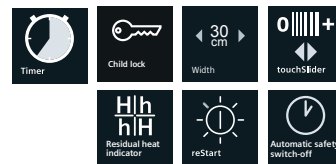

Domino Deep fryer

ET375FAB1E
30cm Deep Fryer

Key Highlights

- Stainless steel frying zone
- touchSlider
- 17 power levels
- reStart function
- Automatic safety switch off

Design & Innovation features

- Black ceramic cover for covering while not being used
- Basin capacity: max 3 - 4 litres
- Frying basket with hanger
- Cold oil zone
- Thermostat setting: 100° - 190°C
- Oil drainage outlet
- Timer
- Energy Consumption display

Safety & Quality features

- Heat up indicator
- Automatic safety switch off
- Childproof lock function

Dimensions

- Appliance dimensions (HxWxD): 22.7cm x 30.2cm x 52cm
- Cutout dimensions (HxWxD): 14cm x 27cm x 49cm - 50cm

Technical Information

- Connecting cable: 100cm
- Total connected load: 2.5 kW
- Temperature range: 100°C - 190°C

Integrated Accessories

- Deep frying basket

Optional Accessories

- HZ394301 - Connecting strip

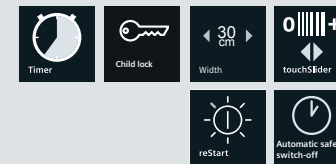
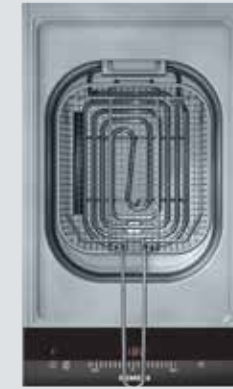

Domino Teppanyaki

ET475FYB1E
40cm Teppanyaki

Key highlights

- Stainless steel cooking zone with touchSlider
- 2 cooking zones (half or full)
- reStart function
- 17 power levels
- Automatic safety switch off

Design & Innovation features

- Stainless steel cooking zone with touchSlider
- Black ceramic cover for covering while not being used
- 2 cooking zones (half or full)
- Thermostat setting: 160° - 240°C
- Keep warm function (at 70°C)
- Zone extension sensor
- Cooking timer setting up to 99 mins
- 17 power levels
- reStart function
- Timer

Safety & Quality features

- Two stage residual heat indicator
- Heat up indicator
- Automatic safety switch off
- Childproof lock function

Dimensions

- Appliance dimensions (HxWxD): 9cm x 39.2cm x 52cm
- Cutout dimensions (HxWxD): 9cm x 36cm x 49cm - 50cm

Technical Information

- Connecting cable: 100cm
- Total connected load: 1.9 kW

Optional accessories

- HZ394301 - Connecting strip

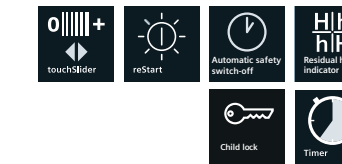

Domino flexInduction hob

EX375FXB1E
30cm flexInduction hob

Key Highlights

- flexInduction hob with touchSlider
- 17 Power levels
- powerMove Plus with 3 steps
- Two stage residual heat indicator for each zone
- Automatic safety switch off

Design & Innovation features

- Front facette design with stainless steel frame
- flexInduction zone: extended cooking surface for multiple pots and pans of any size
- touchSlider
- Cooking zone power: 3.3 kW
- 17 Power levels
- powerMove Plus with 3 steps
- quickStart function
- reStart function
- Energy consumption display
- Cooking timer with switch-off function for all zones
- PowerBoost function for all cooking zones
- Timer

Safety & Quality features

- Two stage residual heat indicator for each zone
- Automatic pan recognition
- Automatic safety switch off
- Childproof lock function

Dimensions

- Appliance dimensions (HxWxD): 5.1cm x 30.2cm x 52cm
- Cutout Dimensions (HxWxD): 5.1cm x 27cm x 49cm - 50cm

Technical Information

- Connecting cable: 110cm
- Total connected load: 3.7 kW

Optional Accessories

- HZ390512 - Teppanyaki (large)
- HZ390511 - Teppanyaki (small)
- HZ390522 - Griddle Plate
- HZ394301 - Connecting strip

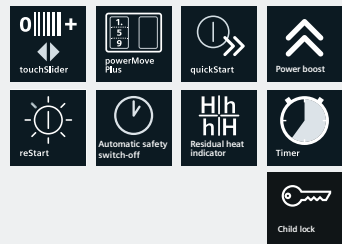
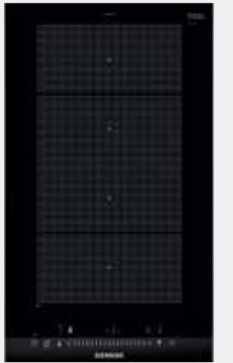

flexInduction Hob

EX675LYC1E
60cm flexInduction Hob

Key Highlights

- Induction hob with Dual lightSlider touch control
- 2 flexInduction zones with flexInduction Plus feature
- powerMove Plus
- fryingSensor Plus with 5 temperature settings
- flexMotion

Design & Innovation features

- Induction hob with Dual lightSlider touch control
- flexInduction zone: extended cooking surface for multiple pots and pans of any size
- flexInduction vector zone on left: 3.3 kW
- flexInduction vector zone on Right: 3.3 kW
- 17 power levels
- flexInduction Plus as extended cooking zone
- powerMove Plus with 3 steps
- fryingSensor Plus with 5 temperature settings
- flexMotion
- Keep warm function
- quickStart function
- reStart function
- Energy consumption display
- Cooking timer for all cooking zones
- powerBoost function for all cooking zones

Safety & Quality features

- Two stage residual heat indicator for each zone
- Wipe protection function
- Automatic pan recognition sensor
- Childproof lock function
- Automatic safety switch off

Dimensions

- Appliance Dimensions (HxWxD): 5.1cm x 60.2cm x 52cm
- Cutout Dimensions (HxWxD): 5.1cm x 56cm x 49cm - 50cm

Technical Information

- Connecting cable: 110cm
- Total connected load: 7.4 kW

Optional Accessories

- HZ390512 - Teppanyaki (large)
- HZ390511 - Teppanyaki (small)
- HZ390522 - Griddle Plate
- HZ394301 - Connecting strip

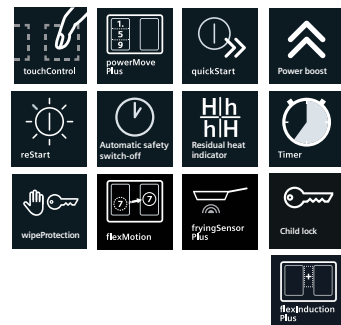

flexInduction Hob

EX275FXB1E
90cm FlexInduction hob

Key Highlights

- 2 flexInduction zones with touchSlider
- 17 power levels
- Energy Consumption display
- Two stage residual heat indicator for each zone
- Childproof lock function

Design & Innovation features

- 2 flexInduction zones with touchSlider
- flexInduction zone: extended cooking surface for multiple pots and pans of any size
- flexInduction vector zone on left: 3.3 kW
- flexInduction vector zone on Right: 3.3 kW
- 17 power levels
- quickStart function
- reStart function
- Energy Consumption display
- Cooking timer for all cooking zones
- powerBoost function for all cooking zones

Safety & Quality features

- Two stage residual heat indicator for each zone
- Wipe protection function
- Automatic pan recognition sensor
- Childproof lock function
- Automatic safety switch off

Dimensions

- Appliance Dimensions (HxWxD): 5.1cm x 91.2cm x 35cm
- Cutout Dimensions (HxWxD): 5.1cm x 88cm x 33cm

Technical Information

- Connecting cable: 110cm
- Total connected load: 7.4 kW

Optional Accessories

- HZ390512 - Teppanyaki (large)
- HZ390511 - Teppanyaki (small)
- HZ390522 - Griddle Plate

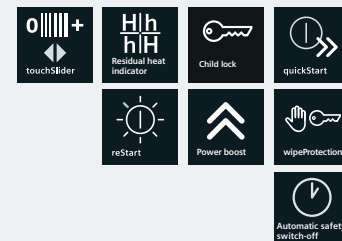

Accessories - Hobs

Accessory No.	Image	Name	Accessory for	Description
HZ298114		Small pot support	ER9A6SD70 EP9A6QB90 EP6A6HB20 EC845IB90E	Small pot support are designed to secure small pots from bottom so that food can be cooked properly with stability.
HZ298105		Simmer plate	ER9A6SD70 EC9A5SB90 EP9A6QB90 EC9A5RB90 EP6A6HB20 EC6A5HB90 EC845IB90E ER3A6BD70 ER3A6AD70	Simmer plate fits right over the burner and helps to diffuse the heat while providing a wider range of temperature control which also helps prevent hot spots in your pan.
HZ298107		Wok ring	EC9A5RB90 EC845IB90E	The ring improves the wok stability and functionality by providing a support from the bottom.

Accessories - Hobs

Accessory No.	Image	Name	Accessory for	Description
HZ390512		Teppanyaki (Large)	EX275FXB1E EX675LYC1E EX375FXB1E	Heating extremely quickly the Teppanyaki is great for fast Japanese cooking. Perfect for a cooked breakfast or a healthy stir-fry. The pan comes in two sizes that fit across either three or four flexInductors.
HZ390511		Teppanyaki (small)	EX275FXB1E EX675LYC1E EX375FXB1E	Heating extremely quickly the Teppanyaki is great for fast Japanese cooking. Perfect for a cooked breakfast or a healthy stir-fry. The pan comes in two sizes that fit across either three or four flexInductors.
HZ390522		Griddle Plate	EX275FXB1E EX675LYC1E EX375FXB1E	Specially designed for use across four flexInductors the griddle pan maintains an even heat, perfect for frying chicken, fish or veggies.
HZ394301		Connecting Strip	ER3A6AD70 ER3A6BD70 ET375FUB1E ET375FAB1E ET475FYB1E EX375FXB1E EX675LYC1E	A joining strip is normally used to join the hobs together, which is a much neater looking and easier to clean installation. Also, it protects from the water to get inside and maintains the heat level of individual hobs as they are placed closed to each other.





Hoods

Outstanding performance,
intelligently designed.

Siemens hoods have the style quotient you would typically expect from a Siemens appliance. However, it is their sheer effectiveness at dealing with unwanted moisture, cooking odours and noise levels that set them apart. Thanks to our iQdrive motor that enhances your cooking experience exponentially. Your kitchen is not only a place to cook, it's a place to spend quality time with your family and friends.

Siemens hoods work hard to keep your kitchen space fresh, and full of cleaner air whilst also providing ambient lighting. Whether you choose a top-of-the-range iQ700 hood, the state-of-the-art downdraft hood, a classic chimney hood or something built-into your kitchen cupboards, all Siemens hoods come with a quiet and most energy efficient motor so you can enjoy your living space.

Spacious ambience with effective extraction.

Kitchen designs are unique to all of us, so it's important to have an extraction that offers more flexibility. The new Siemens worktop ventilation allows various combinations of domino hobs as well as full size hobs that will open your kitchen up to more possibilities. This space saving installation solution fits perfectly, so the hood is right where it is needed: in front of the hob for effective extraction. The worktop ventilation model is available in recirculation mode only.

It gives you a clear and uncluttered view in open plan kitchens, perfect for realizing the most impressive kitchen designs. Easy operation comes as standard with the sleek touchControl functionality that not only looks good but makes the hood quick to clean. And as it is placed next to the hob, it is easier than ever to focus on your cooking while adjusting the intensity of the hood.



iQdrive motor: Efficient,
quiet and robust.
This is how we simplify
life for you.

Driving our range hoods is the patented iQdrive: A high-performance magnetic motor which is most powerful, silent & durable. The air in the kitchen remains clean and fresh, no matter what you are cooking. The high performance hoods are both wear resistant and pleasantly silent – thanks to the frictionless and iQdrive motor. The brushless mechanism enables it to remain cool – eliminating energy loss and faults typically caused by frictional heat – and also makes it remarkably quiet. Moreover, it convinces by its low power consumption and longlasting quality.

All our hoods come fully fitted with a number of features and benefits.

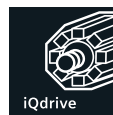

Powerful, efficient and quiet: with iQdrive

Most of our hoods are fitted with compact, efficient and extremely quiet iQdrive motors which save up to 80% energy, even while working at the highest suction level. The iQdrive motor is fitted with an extremely powerful Neodym magnetic core that is built into an inwardly smooth casing, resulting in an optimal aerodynamic air-flow. The fan wheel and scroll housing is constructed to be quiet during an extraction operation, while maintaining a high airflow.



Auto Fan run-on (Delay shut-off)

The hood works for an additional ten minutes to deal with any lingering cooking odours before switching itself off. Some models have an automatic fan run-on facility.



Intuitive selection: touchcontrol interface

Control the power level by simply sliding a finger across the front of the hood using the touchcontrol. A clear LCD display also shows which functions are currently active. As there are no protruding buttons, hoods with touch controls are also easy to keep clean.



Let the range hood decide: Automatic climateControl Sensor

When using the automatic function, a sensor measures the density of vapours and adapts the power level automatically. The manual control is designed in an intuitive way. Here, you can increase the power with the boost function.



Lighting that cool itself down and not the food: with softLight LED

With the longest expected lifetime of 40,000 hours, and power consumption of a mere 3W, the LED lamps ensure a pleasantly, bright kind of illumination above your hob while saving energy at the same time. The softLight dimmer function allows a gentle fading in and out of the lighting, avoiding any unexpected luminance. The atmospheric lighting provides for a very comfortable kitchen ambience.

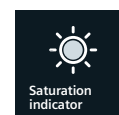

Hoods that remind you to clean the filter: Filter saturation indicator

This feature makes sure that the hood continues to operate at full capacity by reminding you to regularly clean the filters. The display promptly indicates when the grease filters or the activated carbon filters are saturated and need your attention.

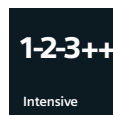

Powerful Speed Level

The Siemens hood allows you to appropriately regulate the extraction power according to the cooking intensity, thus ensuring that energy is saved and noise levels are low. You can choose between 1 to 3 normal levels depending on the model and type of cooking you are doing. There are 2 more intensive levels for heavy cooking and frying.



Low-fat recipe for your kitchen: the patented rim ventilation filter

The innovative and easy-to-clean rim extraction absorbs more than 90% of the grease in the vapours – which is a lot more than other hoods do. Also, its modern design with stainless steel surface makes it something special.

Create an ambience and enjoy the convenience.

Varied extractions for every condition: Automatic intensive revert function

You can use the intensive setting to temporarily boost the extraction rate to cope with particularly demanding cooking conditions, for instance while stir-frying. Models that feature the automatic revert function will automatically drop back to a normal level after ten minutes at the intensive rate – so you never have to remember to switch it back yourself.



Keep your kitchen fresh always: Automatic interval function

Keep your kitchen fresh throughout the day. Proper air circulation is the basic requirement for a healthy indoor climate, not only during cooking. The automatic interval function assures an optimal kitchen climate 24 hours a day. Once activated, the kitchen will automatically be ventilated at hourly intervals (5 mins.) on the lowest fan setting, 24 hours a day. On this setting, the hood will ventilate the kitchen for a few minutes every hour on the lowest fan setting. It's ideal for removing strong, lingering cooking odours like those of curries, fish etc.



Maximum Power: Boost function

During heavy frying when a large amount of steam is let off, you can immediately select the boost option. It activates the boost function, which switches to the maximum intensive setting. The chimney hood will run at maximum power for approx. 20 seconds after which it will automatically get back to the previous power level.

Cascade filter

With the new cascade filter, grease reduction reaches up to 95% for wall mounted design and up to 99% for island chimney hoods. As there are 2 filters in the hood, an extra-large filter surface is achieved. The vapors drawn in are pre-filtered before being filtered a second time via the main filter. These filters are dishwasher safe and can be cleaned manually as well.



No greasy surfaces anymore: The stainless steel mesh filter

The mesh filter prevents surfaces from getting greasy and provides clean air in your kitchen. Its high quality appearance emphasizes the appliance's clear design. The filters are easy to remove and clean - even in a dishwasher.



Beautiful and top-quality: The workmanship

Siemens hoods are characterized by their classy stainless steel look with a modern design. Their workmanship with seamless edges is extremely high in quality, and is eye-catching indeed.



User friendly with button lighting:

The electronic control

The control via display is easy as well as intuitive. With the button lighting you can always see which function is currently activated. The digital display shows you the selected power level.

Our hoods will leave you spoilt for choice

With open-plan living becoming more and more popular, a quiet and efficient extractor is necessary to deal with the strong cooking odours as well as the grease-laden air that can otherwise linger throughout the house. As far as style and design are concerned, with the Siemens range of cooker hoods, you'll be spoilt for choice. But there are also two vital technical points to consider while choosing a hood. The first is whether you want the hood to be ducted or re-circulated and the second is its real suction power, which depends on your kitchen space and cooking habits. Here are some helpful pointers you need to consider.

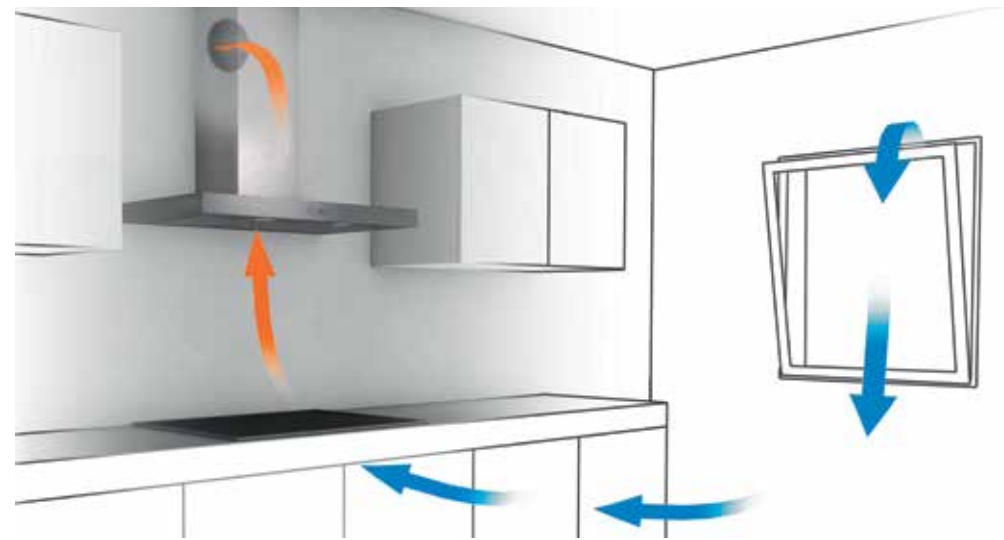

Ducting operational mode

Ducting is appropriate for kitchens which are smaller or average in size. For optimum performance, your extractor hood should be ducted outside the house using ducting with as large a diameter as possible. The larger the size of the duct, the greater the volume of air that can be extracted from the kitchen and the quieter the hood will be. Use of ducting with a lesser diameter should be avoided if possible. Ducting lengths should be as short and as direct as possible to ensure that the air is extracted to outside as quickly as possible. Bends should be kept to a minimum and the ducting itself should be as smooth as possible to ensure smooth, unobstructed airflow.

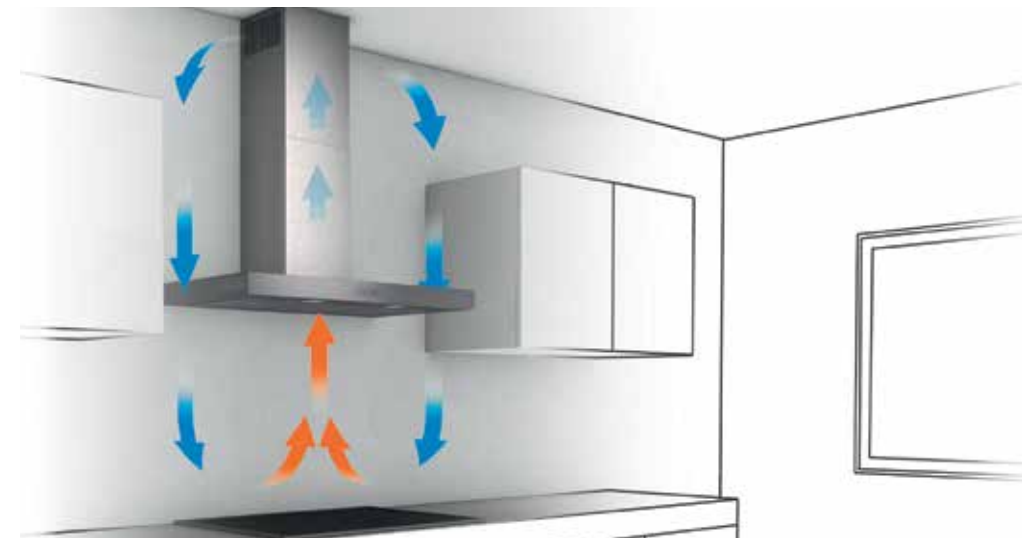

Re-circulated operational mode

Sometimes, the ducting mode is simply not practical or possible. Especially in very large kitchens, where the duct outlet position would require a duct length beyond recommendations, in this case a re-circulation mode shall be chosen (an additional carbon odour filter re-circulated kit is required to do this - please check individual product specifications for details of suitable accessories). In the re-circulated mode, the extracted air is passed through the metal filter to remove grease and then through a carbon filter to remove odours before being directed back into the kitchen. A regular exchange of the filter is required to ensure an effective removal of odours.

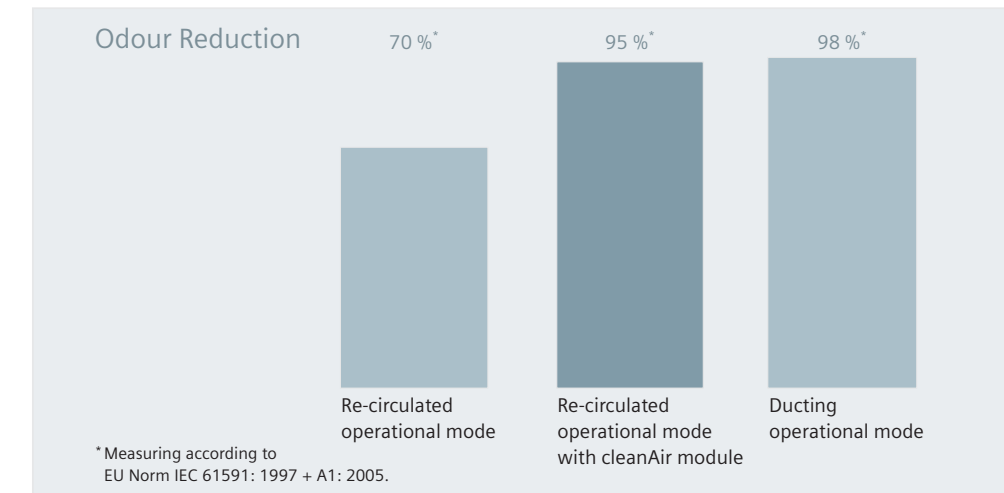

The cleanAir module: making Re-circulation mode as efficient as ducting

The innovative cleanAir module of Siemens prevents the loss of efficiency in removing odour in the re-circulation mode. With the innovative and increased filter surface area, the cleanAir module can neutralize up to 95% of all odours, making it almost as effective as operating the hood in ducting mode. However for optimum performance, your extractor hood should be ducted outside the house, so that the extracted air is vented outside. This sometimes may not be practical.



Real suction power: The power to perform

Your chosen hood must have the ideal power level to effectively remove moisture and cooking odours from your kitchen. As a rule of thumb, the hood should be able to change the air in the kitchen 10 times per hour. Here is a quick calculation you can make to check whether a hood has the right suction power fitting to your kitchen size: firstly, calculate the volume of the kitchen (H x W x D, in metres), then multiply that figure by 10. The resulting figure is the approximate extraction rate you require.

Island Hood

LD97AA670B
90cm Downdraft Hood

Key Highlights

- Telescopic hood with touchControl
- Fan speed: 3 stage + 2 intensive
- LED softLight with dimmer function
- Maximum extraction power: 710 m³/h
- Noise level: 47 dB

Design & Innovation features

- Telescopic table hood
- touchControl with LED display on black glass inlay
- Fan speed: 3 stage + 2 intensive
- LED softLight with dimmer function
- Automatic fan run - on function: duration 15mins.
- Automatic intensive revert function: duration max 10mins.
- Rim ventilation with two aluminium cassette filters;
- Dishwasher safe
- Saturation indicator: grease filter and charcoal filter
- Maximum extraction power: 710 m³/h
- Noise level: 47 dB
- Suitable for re-circulated operations

Dimensions

- Re-circulating Dimensions (HxWxD):
65.2cm – 105.2cm x 88cm x 35.2cm

Technical Information

- Connecting cable: 150cm
- Total Connected load: 285 W

Optional accessories

- LZ53750 - cleanAir active carbon filter



Island Hood

LF21BA552
120cm Island Hood

Key Highlights

- 2 color zone slim box design with two sided controls
- Efficient BLDC motor technology: iQdrive
- Fan speed: 3 stage + 2 intensive
- LED softLight with dimmer function
- Maximum extraction blower power: 1000 m³/h

Design & Innovation features

- 2 color zone slim box design with two sided controls
- Soft touch button control with LED display
- Efficient BLDC motor technology: iQdrive
- Fan speed: 3 stage + 2 intensive
- LED softLight with dimmer function
- Automatic climateControl-Sensor
- Automatic fan run - on function: duration 10mins.
- Automatic Intensive revert function: duration 6mins.
- 4 x rim ventilation filters; Dishwasher safe
- Cascade filter available; dishwasher safe
- Saturation indicator: grease filter and charcoal filter
- Maximum extraction blower power: 720 m³/h
- Noise level: 50 dB
- Suitable for ducted or re-circulated operations

Dimensions

- Exhaust Dimensions (HxWxD):
74.4cm - 92.4cm x 120cm x 65cm
- Re-circulating Dimensions (HxWxD):
79.2cm -104.4cm x 120cm x 65cm

Technical Information

- Connecting cable: 130cm
- Total connected load: 272 W

Optional accessories

- LZ12385 - Chimney extention 160cm
- LZ57600 - cleanAir Recirculating kit
- LZ56200 - cleanAir Active carbon filter

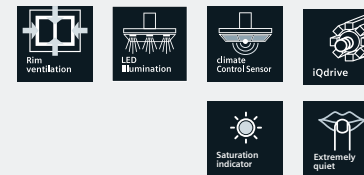

Island Hood

LF98BE542
90cm Island Hood

Key Highlights

- Efficient BLDC motor technology: iQdrive
- Fan speed: 3 stage + 2 intensive
- LED softLight with dimmer function
- Maximum extraction blower power: 870 m³/h
- Noise level: 40 dB

Design & Innovation features

- Box design
- Soft touch button control with LED display
- Efficient BLDC motor technology: iQdrive
- Fan speed: 3 stage + 2 intensive
- LED softLight with dimmer function
- Automatic fan run - on function: duration 10mins.
- Automatic Intensive revert function: duration 6mins.
- Automatic interval function
- 3 x metal mesh filter; Dishwasher safe
- Saturation indicator: grease filter and charcoal filter
- Back pressure flap
- Maximum extraction blower power: 870 m³/h
- Noise level: 40 dB
- Suitable for ducted or re-circulated operations

Dimensions

- Exhaust Dimensions (HxWxD):
74.4cm - 92.4cm x 90cm x 60cm
- Re-circulating Dimensions (HxWxD):
79.2cm -104.4cm x 90cm x 60cm

Technical Information

- Connecting cable: 130cm
- Total connected load: 172 W

Optional accessories

- LZ12385 - Chimney extention 160cm
- LZ57600 - cleanAir Recirculating kit
- LZ56200 - cleanAir Active carbon filter

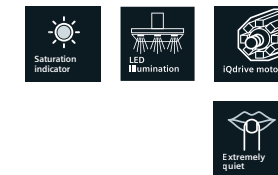

Telescopic Hood

LI97SA530B
90cm Telescopic Hood

Key Highlights

- Efficient BLDC motor technology: iQdrive
- Fan speed: 3 stage + 2 intensive
- LED softLight with dimmer function
- Maximum extraction power: 740 m³/h
- Noise level: 40 dB

Design & Innovation features

- Integrated cabinetry design
- Soft touch button control with LED display
- Efficient BLDC motor technology: iQdrive
- Fan speed: 3 stage + 2 Intensive
- LED softLight with dimmer function
- Automatic fan run - on function: duration 10mins.
- Automatic Intensive revert function: duration 6mins.
- 3 x metal mesh filters; Dishwasher safe
- Saturation indicator: grease filter and charcoal filter
- Soft close drawer
- Maximum extraction power: 740 m³/h
- Noise level: 40 dB
- Suitable for ducted or re-circulated operations

Dimensions

- Exhaust / Re-circulating Dimensions (HxWxD):
42.6cm x 89.8cm x 29cm

Technical Information

- Connecting cable: 175cm
- Total connected load: 146 W

Integrated accessories

- Stainless steel handle strip

Optional accessories

- LZ45650 - Recirculating kit
- LZ45610 - Active carbon filter
- LZ49200 - Installation kit*

* Installation kit is mandatory to fix the 90cm telescopic hood between the cabinets to avoid damages and has to be ordered separately.

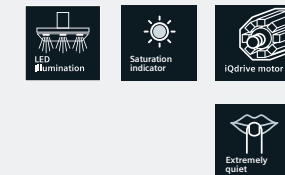

Telescopic Hood

LI64MA530
60cm Telescopic Hood

Key Highlights

- Efficient BLDC motor technology: iQdrive
- Fan speed: 3 stage + Intensive
- LED softLight with dimmer function
- Maximum extraction power: 420 m³/h
- Noise level: 45 dB

Design & Innovation features

- Integrated cabinetry design
- Soft touch button control with display
- Efficient BLDC motor technology: iQdrive
- Fan speed: 3 stage + Intensive
- 2 x LED lights
- Automatic fan run - on function: duration 10mins.
- Automatic Intensive revert function: duration 6mins.
- Metal mesh filters; Dishwasher safe
- Back pressure flap
- Maximum extraction power: 420 m³/h
- Noise level: 45 dB
- Suitable for ducted or re-circulated operations

Dimensions

- Exhaust Dimensions (HxWxD):
20.3cm x 59.8cm x 29cm

Technical Information

- Connecting cable: 175cm
- Total connected load: 76 W

Integrated accessories

- Stainless steel handle strip

Optional accessories

- LZ53450 - Recirculating kit
- LZ45510 - Active carbon filter

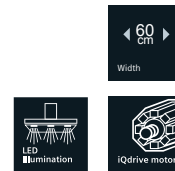

Wall Mounted Hood

LC91KWP60
90cm Wall Mounted Hood

Key Highlights

- Efficient BLDC motor technology: iQdrive
- Fan speed: 3 stage + 2 intensive
- LED softLight with dimmer function
- Maximum extraction power: 950 m³/h
- Noise level: 56 dB

Design & Innovation features

- Inclined Glass design
- Touch control
- Efficient BLDC motor technology: iQdrive
- Fan speed: 3 stage + 2 intensive
- LED softLight with dimmer function
- Automatic fan run - on function: duration 10mins.
- Automatic Intensive revert function: duration 6mins.
- 3 x rim ventilation filters; Dishwasher safe
- Back pressure flap
- Saturation indicator: grease filter and charcoal filter
- Maximum extraction power: 950 m³/h
- Noise level: 56 dB
- Suitable for ducted or re-circulated operations

Dimensions

- Exhaust Dimensions (HxWxD):
93cm - 120cm x 90 cm x 49.9cm
- Re-circulating Dimensions (HxWxD):
99cm - 126cm x 90cm x 49.9 cm

Technical Information

- Connecting cable: 130cm
- Total connected load: 266 W

Optional accessories

- LZ12365 - Chimney extension 150cm
- LZ10AKT00 - Recirculating Kit
- LZ10AKA00 - Active carbon filter

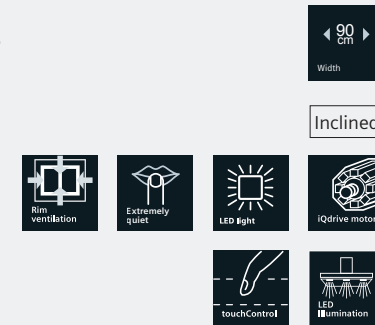

Wall Mounted Hood

LC91BA572
90cm Wall Mounted Hood

Key Highlights

- Efficient BLDC motor technology: iQdrive
- Fan speed: 3 stage + 2 intensive
- LED softLight with dimmer function
- Maximum extraction power: 690 m³/h
- Noise level: 52 dB

Design & Innovation features

- Slim box design
- Touch control
- Efficient BLDC motor technology: iQdrive
- Fan speed: 3 stage + 2 intensive
- LED softLight with dimmer function
- Automatic fan run - on function: duration 10mins.
- Automatic Intensive revert function: duration 6mins.
- 3 x rim ventilation filters; Dishwasher safe
- Cascade filter available; Dishwasher safe
- Saturation indicator: grease filter and charcoal filter
- Maximum extraction power: 690 m³/h
- Noise level: 52 dB
- Suitable for ducted or re-circulated operations

Dimensions

- Exhaust Dimensions (HxWxD):
62.8cm - 95.4cm x 90cm x 50cm
- Re-circulating Dimensions with cleanAir module (HxWxD):
68.9cm x 90cm x 50cm (mounting with outer chimney)
80.9cm - 113.9cm x 90cm x 50cm (mounting with telescopic chimney)

Technical Information

- Connecting cable: 130cm
- Total connected load: 269 W

Optional accessories

- LZ12365 - Chimney extension 150cm
- LZ57300 - cleanAir Recirculating kit
- LZ56200 - cleanAir Active carbon filter

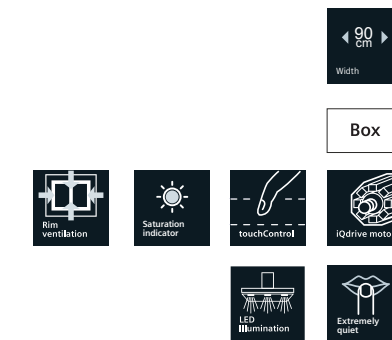

Wall Mounted Hood

LC91BD552I
90cm wall Mounted Hood

Key Highlights

- Efficient BLDC motor technology: iQdrive
- Fan speed: 3 stage + 2 intensive
- LED softLight with dimmer function
- Maximum extraction blower power: 1000 m³/h
- Noise level: 52 dB

Design & Innovation features

- 2 color zone slim box design
- Soft touch button control with LED display
- Efficient BLDC motor technology: iQdrive
- Fan speed: 3 stage + 2 intensive
- LED softLight with dimmer function
- Automatic climateControl-Sensor
- Automatic fan run - on function: duration 10mins.
- Automatic Intensive revert function: duration 6mins.
- 3 x rim ventilation filters; Dishwasher safe
- Saturation indicator: grease filter and charcoal filter
- Back pressure flap
- Maximum extraction blower power: 1000 m³/h
- Noise level: 52 dB
- Suitable for ducted or re-circulated operations

Dimensions

- Exhaust Dimensions (HxWxD):
62.8cm - 95.4cm x 90cm x 50cm
- Re-circulating Dimensions (HxWxD):
62.8cm - 106.4cm x 90cm x 50cm

Technical Information

- Connecting cable: 130cm
- Total connected load: 269 W

Optional accessories

- LZ12365 - Chimney extension 150cm
- LZ53450 - Recirculating kit
- LZ53451 - Active carbon filter



Wall Mounted Hood

LC98BD5421

90cm Wall Mounted Hood

Key Highlights

- Efficient BLDC motor technology: iQdrive
- Fan speed: 3 stage + 2 intensive
- LED softLight with dimmer function
- Maximum extraction blower power: 860 m³/h
- Noise level: 41 dB

Design & Innovation features

- 2 color zone box design
- Soft touch button control with LED display
- Efficient BLDC motor technology: iQdrive
- Fan speed: 3 stage + 2 intensive
- LED softLight with dimmer function
- Automatic fan run - on function: duration 10mins.
- Automatic Intensive revert function: duration 6mins.
- 3 x metal mesh filters; Dishwasher safe
- Saturation indicator: grease filter and charcoal filter
- Maximum extraction blower power: 860 m³/h
- Noise level: 41 dB
- Suitable for ducted or re-circulated operations

Dimensions

- Exhaust Dimensions (HxWxD): 64.2cm - 95.4cm x 90cm x 50cm
- Re-circulating Dimensions (HxWxD): 64.2cm - 106.4cm x 90cm x 50cm

Technical Information

- Connecting cable: 130cm
- Total connected load: 169 W

Optional accessories

- LZ12365 - Chimney extension 150cm
- LZ53450 - Recirculating kit
- LZ53451 - Active carbon filter

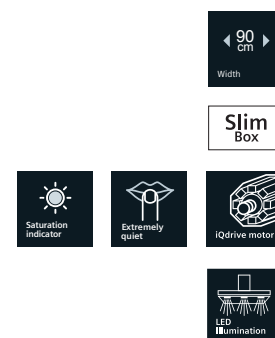

Wall Mounted Hood

LC91BB542

90cm Wall Mounted Hood

Key Highlights

- Efficient BLDC motor technology: iQdrive
- Fan speed: 3 stage + 2 intensive
- LED softLight with dimmer function
- Maximum extraction blower power: 810 m³/h
- Noise level: 52 dB

Design & Innovation features

- Slim box design
- Soft touch button control with LED display
- Efficient BLDC motor technology: iQdrive
- Fan speed: 3 stage + 2 intensive
- LED softLight with dimmer function
- Automatic fan run - on function: duration 10mins.
- Automatic Intensive revert function: duration 6mins.
- 3 x rim ventilation filters; Dishwasher safe
- Saturation indicator: grease filter and charcoal filter
- Back pressure flap
- Maximum extraction blower power: 810 m³/h
- Noise level: 52 dB
- Suitable for ducted or re-circulated operations

Dimensions

- Exhaust Dimensions (HxWxD): 62.8cm - 95.4cm x 90cm x 50cm
- Re-circulating Dimensions (HxWxD): 62.8cm - 106.4cm x 90cm x 50cm

Technical Information

- Connecting cable: 130cm
- Total connected load: 269 W

Optional accessories

- LZ12365 - Chimney extension 150cm
- LZ53450 - Recirculating kit
- LZ53451 - Active carbon filter

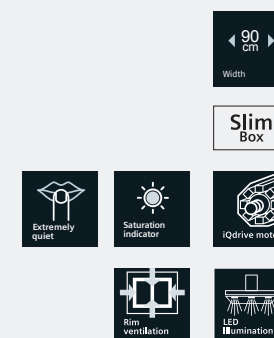

Wall Mounted Hood

LC28BH542

120cm Wall Mounted Hood

Key Highlights

- Efficient BLDC motor technology: iQdrive
- Fan speed: 3 stage + 2 intensive
- LED softLight with dimmer function
- Maximum extraction power: 830 m³/h
- Noise level: 41 dB

Design & Innovation features

- Box design
- Soft touch button control with LED display
- Efficient BLDC motor technology: iQdrive
- Fan speed: 3 stage + 2 intensive
- LED softLight with dimmer function
- Automatic fan run - on function: duration 10mins.
- Automatic Intensive revert function: duration 6mins.
- 4 x metal mesh filter; Dishwasher safe
- Saturation indicator: grease filter and charcoal filter
- Maximum extraction power: 830 m³/h
- Noise level: 41 dB
- Suitable for ducted or re-circulated operations

Dimensions

- Exhaust Dimensions (HxWxD): 64.2cm - 95.4cm x 90cm x 50cm
- Re-circulating Dimensions (HxWxD): 64.2cm - 106.4cm x 90cm x 50cm

Technical Information

- Diameter pipe: 12cm / 15cm
- Connecting cable: 130cm
- Total connected load: 169 W

Optional accessories

- LZ12365 - Chimney extension 150cm
- LZ53450 - Recirculating kit
- LZ53451 - Active carbon filter

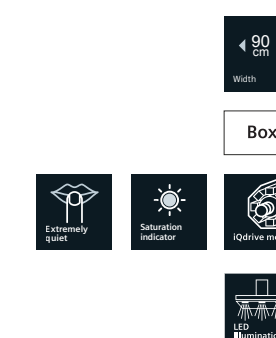

Wall Mounted Hood

LC68BF542

60cm Wall Mounted Hood

Key Highlights

- Efficient BLDC motor technology: iQdrive
- Fan speed: 3 stage + 2 intensive
- LED softLight with dimmer function
- Maximum extraction blower power: 760 m³/h
- Noise level: 46 dB

Design & Innovation features

- Slim box design
- Soft touch button control with LED display
- Efficient BLDC motor technology: iQdrive
- Fan speed: 3 stage + 2 intensive
- LED softLight with dimmer function
- Automatic fan run - on function: duration 10mins.
- Automatic Intensive revert function: duration 6mins.
- 2 x metal mesh filters; Dishwasher safe
- Saturation indicator: grease filter and charcoal filter
- Maximum extraction blower power: 760 m³/h
- Noise level: 46 dB
- Suitable for ducted or re-circulated operations

Dimensions

- Exhaust Dimensions (HxWxD): 62.8cm - 95.4cm x 60cm x 50cm
- Re-circulating Dimensions (HxWxD): 62.8cm - 106.4cm x 60cm x 50cm

Technical Information



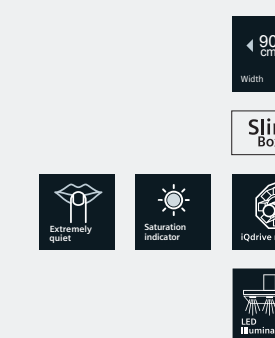

- Connecting cable: 130cm
- Total connected load: 166 W

Optional accessories

- LZ12365 - Chimney extension 150cm
- LZ53450 - Recirculating kit
- LZ53451 - Active carbon filter



Accessories - Hoods

Accessory No.	Image	Name	Accessory for	Description
LZ53750		carbon filter	LD97AA670B	cleanAir module is used in recirculation made for table ventilation. This helps reducing the intensive odour as it consists of high carbon content filter and also ensures the noise is reduced for better extraction performance.
LZ12385		Chimney extention 160cm	LF21BA552 LF98BE542	Chimney extention are used when the height of the kitchen is really high. It also has a recirculation slot that can be used on recirculation mode as well as ducting mode.
LZ57600		cleanAir Recirculating kit	LF21BA552 LF98BE542 LC91BA572	cleanAir module is used in recirculation mode for any island hood. The kit consists of a cleanAir active carbon filter, wall unit and flexible tube that includes fixation elements and stainless steel outer panel.
LZ45650		Recirculating kit	LI97SA560B LI64MA530 LC98BH542	cleanAir module is used in recirculation mode for any island hood. The kit consists of a cleanAir active carbon filter, wall unit and flexible tube that includes fixation elements and stainless steel outer panel.



Accessories - Hoods

Accessory No.	Image	Name	Accessory for	Description
LZ45610		Active carbon filter	LI97SA560B LI64MA530	cleanAir carbon filter is used in recirculation mode for any wall mounted hood. This helps reducing the intensive odour as it consists of high carbon content filter and also ensures the noise is reduced for better extraction performance.
LZ49200		Installation kit	LI97SA560B	This accessory is mandatory to use only when the 90cm telescopic hood is installed under 90cm wide wall cabinet. In case of 60cm wide wall cabinet, this accessory cannot be used. The installation kit ensures the hood is properly fixed between the cabinets to avoid any damage.
LZ12365		Chimney Extension 150cm	LC91KWP60 LC91BD552I LC98BD542I LC28BH542 LC98BD542 LC98BH542 LC98WA542 LC68BF542	The hood is attached to the wall and the ceiling is slightly higher than average height. It can be used on recirculation mode as well as ducting mode.

Accessories - Hoods

Accessory No.	Image	Name	Accessory for	Description
LZ53450		Recirculating kit	LC91KB672 LC91BD552I LC98BD542I LC91BB542 LC98WA542 LC28BH542 LC68BF542	When the hood is installed in recirculation mode, the recirculation kit is required. The kit consists of a hose, activated carbon filters, clamps and recirculation air guide.
LZ53451		Active carbon filter	LC91KB672 LC91BD552I LC98BD542I LC98BH542 LC68BF542 LC28BH542 LC98WA542	In recirculation mode, the odour particles need to be eliminated by an activated carbon filter. Bigger filters will ensure capturing of more odour particles and warm/dry filters will ensure higher efficiency.
LZ57300		Clear Air Recirculating kit	LC91BA572	cleanAir module is used in recirculation mode for any wall mounted hood. The kit consists of a cleanAir active carbon filters, Wall unit and flexible tube including fixation elements and stainless steel outer panel.
LZ56200		CleanAir Active Carbon Filter	LF21BA552 LF98BE542 LC91BA572	cleanAir carbon filter is used in recirculation mode for any wall mounted hood. This helps reducing the intensive odor as it consists of high carbon content filter and also ensures the noise is reduced for better extraction performance.

Accessories - Hoods

Accessory No.	Image	Name	Accessory for	Description
LZ10AKA00		Active carbon filter	LC91KWP60	cleanAir carbon filter is used in recirculation mode for any wall mounted hood. This helps reducing the intensive odour as it consists of high carbon content filter and also ensures the noise is reduced for better extraction performance.
LZ10AKT00		Recirculating kit	LC91KWP60	When the hood is installed in recirculation mode, the recirculation kit is required. The kit consists of a hose, activated carbon filters, clamps and recirculation air guide.

Coffee Centre Meant for the coffee connoisseurs.



The finishing touch for your kitchen or dining area, the Siemens coffee machine is the ultimate appliance for coffee lovers and those who like to entertain. The central control dial and TFT full colour display with interactive menu continues the iQ700 design story, whilst the concealed milk container achieves the classically understated Siemens look.

The sophisticated, fully automatic built-in iQ700 Coffee Center offers a wide selection of beverages, ranging from a strong and aromatic ristretto to an impeccably made, milk-froth cappuccino - all available at the touch of the oneTouch Function. With all these options, it's truly your Barista at home. For a life less ordinary, indeed!

Ristretto | Espresso | Espresso Macchiato | Cappuccino | Latte | Macchiato |
Milk froth | Warm milk | Hot water for varieties of tea.

Coffee Centre that understands that there's nothing like a perfect cup of coffee!



TFT Colour Touch Display with graphics

It has never been this easy to keep an eye on everything. Thanks to the menu structure, which is optimized for convenient and easy-to-use touch navigation, the new TFT color touch display is the most innovative and intuitive user interface available. Designed to serve one purpose: giving you full control.



Ideal Brewing temperature for maximum aroma: SensoFlow System – an intelligent heater

Imagine a coffee machine that automatically detects the brewing method based on the kind of coffee bean used. The innovative Sensoflow heating system does just that and much more. It gives you the perfect cup of coffee, with its unique aroma intact by regulating the optimum brewing temperature. Moreover, it saves precious resources by heating only when necessary and ensures maximum output at minimum energy use.



Full aroma, incomparable crema: aromaPressure system

Ground coffee from the ceramic grinders is always compressed perfectly, whatever the quantity - releasing even more fantastic flavours from the coffee. Precise pressure and convex tamper from the aromaPressure system, complements the unique SensoFlow System perfectly with consistent brewing temperature and maximum aroma extraction.



Perfectly brewed coffee: coffeeSensor system

Irrespective of the variety of the bean, the coffeeSensor system measures the powder quantity after each grinding process and automatically adapts the time of the following grinding process to the current bean variety. Resulting in always achieving the desired strength and aroma.



Get two perfect beverages at the touch of a button: oneTouch Double Cup

Get two perfectly brewed quality milk beverages at the touch of one button with Siemens coffee center. The automatic milk frother with suction function has double spouts for both coffee and milk.



Effortless cleaning: autoMilk clean

Now no need to clean the milk system daily. One second draft of steam cleans away all the remaining milk after every milk beverage. As a result no milk is left to be dried up, and the milk system can be cleaned only once a week, in a dishwasher or manually, to ensure good hygiene and the highest standards for milk beverages.

Coffee Centre

CT636LES1

45cm Fully Automatic Coffee Machine

Key Highlights

- TFT colour and graphics display with direct touch
- One-touch coffee shop: 8 types of beverages
- SensoFlow system: innovative heating system
- coffeeSensor System: Automatic bean adjustment while grinding
- AromaDouble shot function

Design & Innovation features

- One-touch coffee shop: Ristretto, Espresso, Espresso Macchiato, Coffee, Cappuccino, Latte, Macchiato, Milk froth, Warm milk and Hot water
- AromaDouble shot function
- SensoFlow system: innovative heating system
- oneTouch DoubleCup selection for regular coffee and myCoffee
- Mycoffee: 8 memory slots to save favourite beverages
- individualCup Volume Individual cup sizes adjusted
- Coffee outlet and milk frother height- adjustable: max 15cm
- Removable water tank: 2.4 litres
- Indicator for coffee bean container and water tank
- Flexible milk solution: Milk Container or carton placement
- silentCeram Drive: Premium grinder made from nonwearing ceramic
- coffeeSensor System: Automatic bean adjustment while grinding
- oneTouch function: Automatic milk frother
- aromaPressure system
- Reduced heat-up time: Fastest first cup
- Separate compartment for ground coffee
- autoMilk Clean: Fully-automatic steam cleaning of the milk system
- Milk sensor / reminder: Senses milk container presence



- singlePortion Cleaning: Complete removal of coffee after each brewing process
- Integrated Pre-brew function
- Coffee bean container with aroma preservation lid for 500g
- Brewing chamber: max 12g
- Integrated storage compartment for milk tube, short instruction and coffee powder spoon
- Stainless steel Milk container (0.5 litre) with insulation
- Water level sensor
- Indicator for descaling or cleaning programme

Cleaning Features

- Automatic cleaning system
- Automatic rinsing function
- Dishwasher-safe parts of coffee maker: Drip plate, Water tank lid, Milk nozzle, Milk tube, Trester container and Drip tray
- Display of remaining cups before cleaning or descaling
- Removable plastic spillage collection
- Removable drip tray including container for coffee grounds at the push of a button
- Removable and dishwasher-proof Milk frother
- Removable brewing unit: Easy cleaning
- Short rinse function for milk system

Safety & Quality features

- Childproof lock function
- Safety functions: Coffee maker is locked if trester container is full, bean tank is missing, brewing unit is missing, door is open, drip tray is full, milk nozzle is missing, powder draw is missing, water tank is empty or water tank is missing

Dimensions

- Appliance dimensions (H X W X D): 45.5cm x 59.4cm x 38.5cm
- Cutout dimensions (H X W X D): 44.9cm x 55.8cm x 35.4cm

Technical Information

- Connecting cable: 170cm
- Total connected load: 1.6 kW

Included Accessories

- 9 x assembly screws
- 1 x scoop
- 1 x water filter
- 1 x test strip
- 1 x milk container (insulated)
- 1 x connection hose for milk frother
- 1 x milk pipe

Optional Accessories

- Cleaning tablets - TZ80001
- Descaling tablets - TZ80002

Accessories - Coffee Centre

Accessory No.	Image	Name	Accessory for	Description
TZ80001		Cleaning tablets	CT636LES1	The coffee machine signals for its cleaning after few days of usage. The cleaning ensures the old coffee has been removed from brewing unit area.
TZ80002		Descaling tablets	CT636LES1	The coffee machine would signal for its descaling when required or we can opt for descaling process after continuous usage. This method will ensure removal of minerals from water/milk pipe and other compartments. This method of cleaning will also ensure the taste of the espresso is revived and the ability of milk froth is recovered.



Warmer Drawers

A Siemens warmer drawer is the ideal addition to any kitchen.

We know you believe in less ordinary kitchen experiences! So whether you are keeping food warm, preheating crockery, thawing delicate frozen foods or simply in need of extra storage space, a fully coordinated Siemens warmer or accessory drawer is a must-have for your kitchen. The iQ700 range also has a push and pull mechanism, so the door opens and closes with just a touch of a button.



Warmer drawers are more than just drawers.

Striking elegance

Designed to perfectly blend with the Siemens ovens, compact combi ovens, microwaves and coffee machines, you will have a choice of 14cm or 29cm in height, holding up to 12 or 40 plates respectively, with four temperature options ranging from 40°C - 80°C.

Elegance and practicality combined

Siemens built-in appliances are designed so that a warmer drawer can be aligned below to appear integral to the unit. This is particularly useful when you have built-in, side-by-side appliances of different heights. The seamless fit of the warmer drawer provides a uniform appearance to both appliances and is pleasing to the eye. The additional warmer drawer provides valuable storage space for crockeries or food in a beautiful seamless manner.

Simple cleaning

The warmer drawer's easy-to-clean smooth and hard ceramic glass base is recessed, which allows for any spillage to be easily contained and then easily wiped off.

Easy access

The fully extendable pull-out drawer allows easy access to the substance and can also accommodate up to 25kgs.

Warmer Drawers

Warmer Drawer

BI630CNS1
14cm Warmer Drawer

Key Highlights

- Frameless glass design
- Stainless steel cavity with Push and Pull
- Blue indicator lights
- Rotary control
- 14cm height

Design & Innovation features

- Interior cavity volume: 20 litres
- Maximum load taken: 25kg (up to 12 plates or 64 espresso cups)
- Functions: Dough proving, Defrost, Hold warm and Plate warming
- Adjustable temperature range from 30-80°C
- Easy-to-clean toughened glass heating plate
- Telescopic full extension rails
- coolDoor

Dimensions

- Appliance dimensions (HxWxD): 14cm x 59.4cm x 54.8cm
- Cutout dimensions (H X W X D): 14cm x 56cm x 55cm

Technical Information

- Cavity dimensions (H X W X D): 9.2cm x 46.8cm x 45.8cm
- Connecting cable: 150cm
- Total connected load: 0.81 kW



Warmer Drawer

BI630DNS1
29cm Warmer Drawer

Key Highlights

- Frameless glass design
- Stainless steel cavity with Push and Pull
- Blue indicator lights
- Rotary control
- 29cm height

Design & Innovation features

- Interior cavity volume: 52 litres
- Maximum load taken: 25kg (up to 40 plates or 192 espresso cups)
- Functions: Dough proving, Defrost, Hold warm and Plate warming
- Adjustable temperature range from 30-80° C
- Easy-to-clean toughened glass heating plate
- Telescopic full extension rails
- coolDoor

Dimensions

- Appliance dimensions (HxWxD): 29cm x 59.4cm x 54.8cm
- Cutout dimensions (H X W X D): 29cm x 56cm x 55cm

Technical Information

- Cavity dimensions (H X W X D): 24.2cm x 46.8cm x 45.8cm
- Connecting cable: 150cm
- Total connected load: 0.81 kW



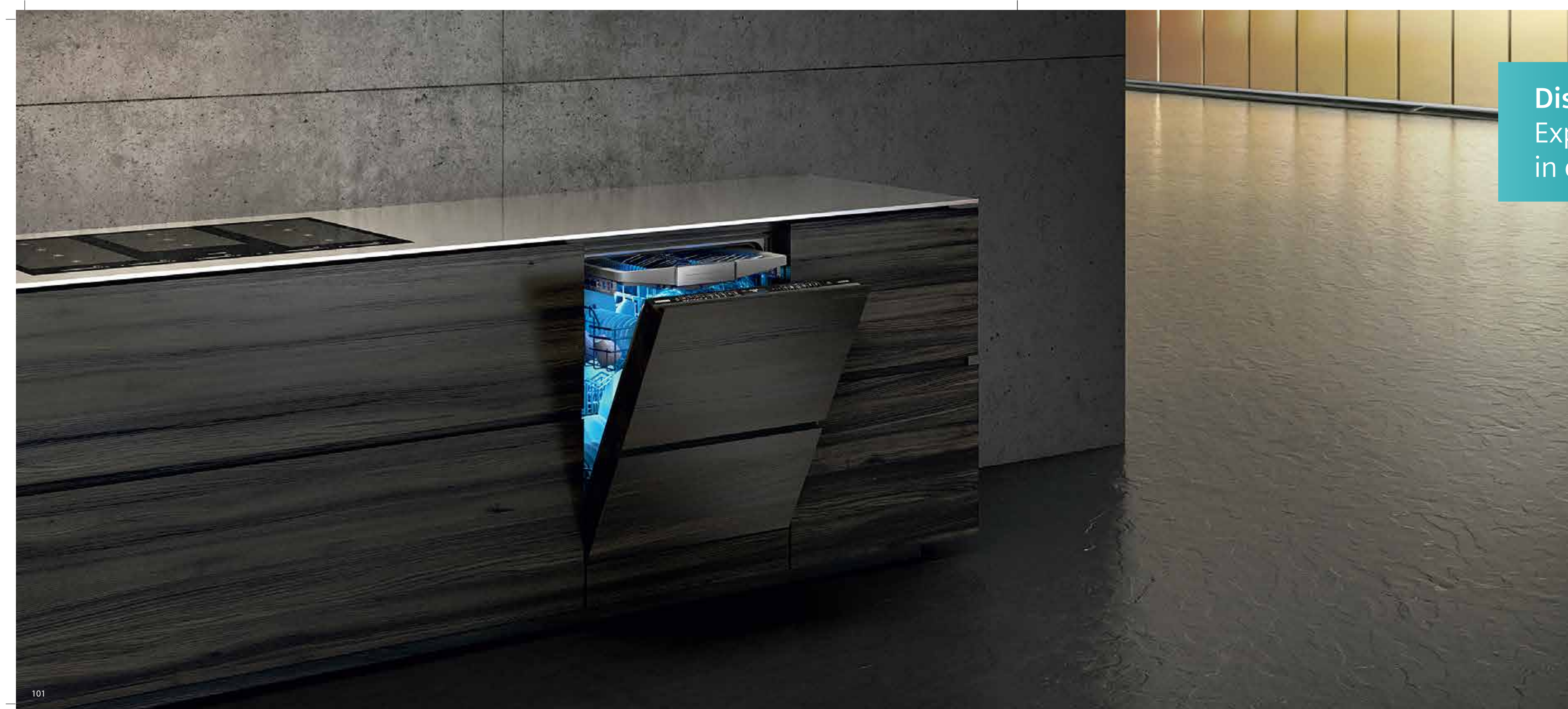

Dishwasher

Experience perfection
in dishwashing.

With state-of-the-art technology, the new iQ700 built-in dishwashers make washing and drying faster and more flexible than ever. iQ700 dishwashers boast of the patented Zeolith® drying technology which optimises water usage to make your kitchen experience more convenient for your urban lifestyle. With their neat and clean built-in design, they blend in perfectly with the rest of your Siemens iQ700 kitchen.

Wonder what a modern modular kitchen craves for? A built-in dishwasher by Siemens.

Live your dream. Live your passion. Live the moment. Live to explore. Live to achieve. Because, there's more to life and there's more for you to explore.

Integrated kitchen décor.

Adds a touch of class to your kitchen with a built-in dishwasher by Siemens. It seamlessly integrates with your kitchen décor. Its understated and classy finish will enhance the look of the kitchen. Needless to say, compliments galore.

Directly integrated into the kitchen cabinet.

Built-in dishwashers by Siemens are a game changer for modern kitchens. Without making its presence felt, it makes more room for things you love the most. So subtle, so discreet - yet so powerful. Disguised behind a kitchen cabinet, it silently does so much more so that you can live more, live extra-ordinary.

Super capacity. Solid performance.

It can wash more than you think it can with many settings tableware at one time. Now, playing a perfect host is easy and managing the after party cleaning is even easier. Thankfully, it's all at the touch of a button and the dishes and utensils will be sparkling once again even before you know it.

Inspires to do more.

Make your life larger than life. Do more simply by making a smart choice that will allow you to go beyond the ordinary. So gear up to dream, explore and discover. Enjoy new experiences and live the life less ordinary with a built-in dishwasher by Siemens by your side.



Semi-integrated

You choose the material. You choose the colour. It's your dishwasher, your way. The Semi-integrated dishwashers from Siemens blend perfectly into your kitchen. The high-quality control panel of the dishwasher remains clearly visible. It comes with superior Siemens design and convenient access to the numerous functions and programmes.



Fully integrated

Subtly brilliant, the Fully Integrated Dishwashers from Siemens come with pure, clean design. And guess what, they are practically invisible. Basking in its own understated glory and underscoring your kitchen's design. The front panel matches the kitchen cabinets, disguising the entire front of the appliance. The control and display elements are located on the top edge of the door, catching your eye only when you open the dishwasher. Innovative technology couldn't be any more discreet.



Zeolith®: A leap in super-efficient drying technology.

Faster drying and lower energy consumption naturally

The dishwasher features a special container of Zeolith®, a mineral with the ability to absorb moisture and convert it into heat. It facilitates a faster drying process, which reduces time taken and energy consumed. This brings the energy consumption down to 0.73 kWh - the world's best energy consumption. Hence the Siemens Dishwasher has been awarded the 'Innovative Prize for Climate and Environment' by the German government.

Lifelong drying

The Zeolith® minerals are stored in the depths of the dishwasher and thanks to the regeneration process, it keeps on working for the entire lifetime of the dishwasher.

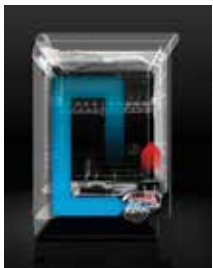

Drying phase

The moisture is absorbed by the Zeolith® minerals, releasing heat energy for supporting the drying process for better drying results at the lowest energy consumption.



Cleaning phase

When Zeolith® minerals are heated, they release the moisture captured from earlier cycles, which helps during the cleaning phase.

Superior innovations. Superior shine.



TFT display

Programme selection is particularly easy with the new, high-resolution TFT display. It presents the activated programme information at a glance - clearly divided, easy to operate, completely organised and therefore quick to view. You can also conveniently select individual programme settings.



Efficient, sturdy and quiet: iQdrive motor

Siemens Dishwashers are powered by the revolutionary iQdrive motor which is quieter, faster and more efficient. They improve the energy performance of the dishwasher. Set your dishwasher to use less energy while maintaining the same performance level. Its innovative magnetic technology drives the iQdrive without friction for a virtually wearfree operation.



Puts your dishes in the right light: emotionLight

Show-off your sparkling clean glassware with the cool blue emotionLight in our top-of-the-range models. Two LEDs at the top of the door frame bathe the interior of the dishwasher and the dishes in cool blue light when you open the door and switches off again when you close it. The LED lights never need to be changed and will last for the lifetime of your dishwasher.



Brilliance at the touch of a button: shine and dry

When selected, the Shine & Dry option helps dishes and glassware come out exceptionally clean with perfect shine by raising the temperature and extending the drying time, for a special gentle drying process.



As clean as it gets: hygienePlus

This option is ideal for washing dishes and utensils to stringent hygienic standards. During the final rinse, the temperature is kept at a constant high level of 70°C for about 10 minutes, eliminating up to 99.99% of all bacteria, giving you the most hygienic wash possible. This is perfect for washing your baby bottles and dishes.



All important information at one projection™: timeLight

Now it is also possible for fully-integrated models to see when the dishwashing cycle™ will be completed. The timeLight projects the cycle status and time remaining, on the kitchen floor to let you know a wash cycle is running and about its progress.

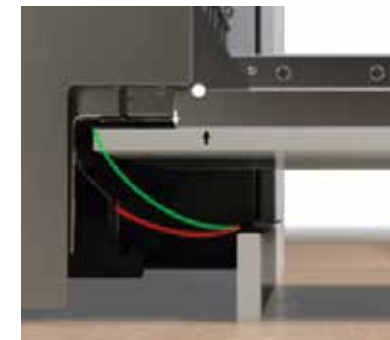

Fixation of furniture front: varioHinge

The furniture front is fixed to the dishwasher door with and by a hinge. When opening the door, the furniture front on top moves. Thus, a collision of the furniture front with plinth and base is avoided. With the variable hinge varioHinge, a minimal plinth height of 6.5 cm can be realized. (Depending on the built-in situation)

Ideal installation aid: the VarioHinge pushes the furniture panel upwards, and the appliance door opens easily.



Gentle on top, high pressure below. Ideal for mixed load: intensiveZone

The intensiveZone option makes cleaning of soiled pots and fragile glasses together possible. It generates more spray pressure in the lower basket so that the most stubborn soiling is taken care of, while the top basket remains unchanged. A perfect dishwashing result is guaranteed even for mixed loads.



Washing and drying, upto 66% faster: varioSpeed Plus

varioSpeed Plus reduces the cycle time by up to 66%. Dishes are perfectly cleaned and dried with same perfect washing result at shortest time.

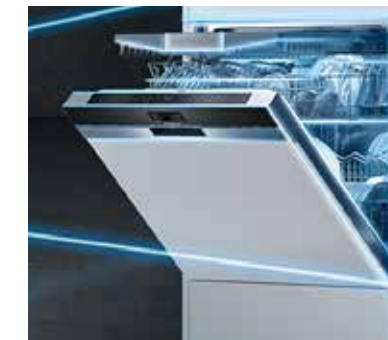

Control your appliances. Anytime, anywhere: Home connect

As innovation moves on, new possibilities arise. Thanks to Wi-Fi-enabled Siemens home appliances with Home Connect functionality, they make their way into your home and enrich your everyday life. Making your everyday life as efficient and comfortable as never before and allowing you to spend more time and attention on the things you really love to do. For a life less ordinary. Remote controlling lets you select options, and start programs intuitively wherever you are.

*The availability of the Home connect functionality depends on the availability of the Home connect services in your country. Home connect services are not available in every country - For further information please check: www.home-connect.com

Superior technology. More convenience.

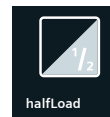

Load without restrictions and worries: halfLoad

The halfLoad option is perfect for smaller households and allows total freedom on where to stack the dishes. It also saves up to 20% of water and 10% of energy whilst maintaining the best wash performance. A convenient option when you don't want to wait for a full load.



Unleash the full power of detergent tablets: dosageAssist

In many dishwashers, tablets are launched into the cavity in an uncontrolled manner, without always achieving their full effect. With dosageAssist, the dishwashing tablet is carefully directed from the detergent chamber into a small catch pan at the front of the upper basket. Precision water jets control the dissolving tablet, ensuring even distribution for perfect, sparkling results. You can, of course, continue to use powder and gel cleaners with dosageAssist.

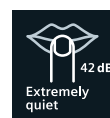

Whisper-soft dishwasher

Our special sound insulation technology has made Siemens dishwashers particularly quiet in operation. The innovative pump which pushes the water out of the machine will automatically turn off when no excess water has to be removed, thus eliminating the unpleasant pumping sound. Selected models operate at no more than 42 dB, making them even quieter than whispering.



Higher flexibility and convenience: rackMatic™

rackMatic™ gives you the flexibility to adjust the upper basket to accommodate taller glasses or large saucers. Bigger utensils can be stacked at the bottom by lifting the upper basket, this adjustment can be made even when the dishwasher is loaded.



No water damage. No water wastage: aquaStop®

The aquaStop® system guarantees 100% lifelong safety - guaranteed against water damage. If a leak does occur, aquaStop® immediately cuts off the water supply from the tap, even when the dishwasher is switched off.

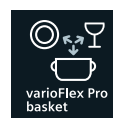

Great comfort on all levels: varioFlex Pro baskets and varioDrawer Pro

With its various foldable and flexible tines, the new varioFlex Pro baskets and varioDrawer Pro provide maximum flexibility and space for all your utensils. In the new and improved dishwashers, thanks to the glass holders in the top basket, wine glasses will easily find a right and stable place. Bigger utensils will find their space in the bottom basket. The blue coloured touch points indicate adjustments within the basket at first glance. Loading the dishwasher has never been as comfortable.

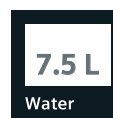

Low water consumption at only 7.5 litres

Using the dishwasher is a more efficient cleaning method than doing dishes by hand. Dishwashers consume significantly less water, less detergent and less electricity. Compared to dishes washed by hands which consume more than 100 litres of water, our dishwashers consume as low as 7.5 litres of water for an entire cycle to give you clean dishes as desired. At Siemens, we try our best to ensure our dishwashers are flexible, versatile and save water and energy like never before.

Dishwashers

Dishwasher

SN758X06TE

60 cm, Fully integrated, Zeolith drying, Vario Hinge, 14 place settings

Key Highlights

- Zeolith drying
- Home Connect ready
- varioHinge
- iQdrive
- Aqua-Sensor, Load-Sensor

Design & Innovation

- Machine Care Programme
- Self-cleaning filter system with 3-fold corrugated filter
- Acoustic end of cycle indicator
- Electronic delay timer: 1-24 hours
- LED salt refill indicator
- LED rinse aid refill indicator
- VarioFlex Pro basket system with blue coloured touchpoints
- VarioDrawer Pro
- Silver XXL baskets with pullout handle
- rackMatic height-adjustable top basket (3 stage)
- 6 foldable plate racks in top basket
- 8 FlexTines in bottom basket
- 2 cup shelves in top basket
- 2 cup shelves in bottom basket
- Glass rack in bottom basket
- AquaStop with guarantee
- Door latch

Programmes & Options

- 8 programmes: Intensive 70 °C, Auto 45-65 °C, Eco 50 °C, Silence 50 °C, Short 60 °C, Glass 40 °C, Quick 45 °C, Pre Rinse
- 4 special options: Remote Start, Intensive Zone, VarioSpeedPlus, Extra Dry

Technical information

- Energy consumption in Program Eco 50: 0.83 kwh
- Water consumption in Program Eco 50: 9.5 l
- Noise level: 42 dB
- Noise level (silence programme): 40 dB
- Product dimensions (HxWxD): 81.5 x 59.8 x 55 cm



Dishwasher

SN558S06TE

60 cm, Semi- integrated, Zeolith Drying, 14 place settings

Key Highlights

- Vario Speed Plus
- Zeolith drying
- Home-connect ready
- iQdrive
- Aqua-Sensor, Load-Sensor

Design & Innovation

- Detergent Automation
- Heat exchanger
- Alternating spray technique
- Regenerative electronics
- Real-time clock
- High-definition colour TFT display showing graphic symbols and plain text
- Interior tub material: Stainless Steel
- Machine Care Programme
- Self-cleaning filter system with 3-fold corrugated filter
- Electronic delay timer: 1-24 hours
- LED salt refill indicator
- LED rinse aid refill indicator
- VarioFlex Pro basket system with blue coloured touchpoints
- VarioDrawer Pro
- Silver XXL baskets with pullout handle
- rackMatic height-adjustable top basket (3 stage)
- 6 foldable plate racks in top basket
- 8 FlexTines in bottom basket
- 2 cup shelves in top basket
- 2 cup shelves in bottom basket
- Glass rack in bottom basket
- AquaStop with guarantee
- Childproof control lock

Programmes & Options

- 8 programmes: Intensive 70 °C, Auto 45-65 °C, Eco 50 °C, Silence 50 °C, Short 60 °C, Glass 40 °C, Quick 45 °C, Pre Rinse
- 4 special options: Remote Start, Intensive Zone, Extra Dry

Technical information

- Energy consumption in Program Eco 50: 0.83 kwh
- Water consumption in Program Eco 50: 9.5 l
- Noise level: 42 dB
- Noise level (silence programme): 40 dB
- Product dimensions (HxWxD): 81.5 x 59.8 x 57.3 cm



*Energy and water consumption of the standard Eco 50 C programme: Actual consumption value will depend on how the appliance is used. Important information (applicable for all models): Water pressure of 1 to 10 bar and 15 A plug point are pre-requisite.

*Energy and water consumption of the standard Eco 50 C programme: Actual consumption value will depend on how the appliance is used. Important information (applicable for all models): Water pressure of 1 to 10 bar and 15 A plug point are pre-requisite.

Dishwasher

SN636X00ME

60 cm, Fully-integrated, 14 place settings

Key Highlights

- varioSpeed Plus
- iQdrive
- Aqua-Sensor, Load-Sensor
- Acoustic end of cycle indicator
- infoLight

Design & Innovation

- speedMatic hydraulic system
- dosageAssist
- 5 cleaning temperatures
- Self-cleaning filter system with 3-fold corrugated filter
- Remaining programme time indicator (min)
- Electronic delay timer: 1-24 hours
- LED salt refill indicator
- LED rinse aid refill indicator
- VarioFlex basket system
- VarioDrawer
- Silver XXL baskets
- rackMatic height-adjustable top basket (3 stage)
- 2 foldable plate racks in top basket
- 4 foldable plate racks in bottom basket
- 2 cup shelves in top basket
- AquaStop with guarantee
- Door latch
- Detergent Automation
- Heat exchanger
- Alternating spray technique
- Regenerative electronics
- Interior tub material: Stainless Steel
- Glass care protection system

Programmes & Options

- 6 programmes: Intensive 70 °C, Auto 45-65 °C, Eco 50 °C, Silence 50 °C, Glass 40 °C, 1h 65 °C
- 2 special options: varioSpeed Plus, Extra Trocknen

Technical information

- Energy consumption in Program Eco 50: 0.93 kwh
- Water consumption in Program Eco 50: 9.5 l
- Noise level: 46 dB
- Noise level (silence programme): 43 dB
- Product dimensions (HxWxD): 81.5 x 59.8 x 55 cm



Dishwasher

SN536S01KE

60 cm, Semi-integrated, 13 place settings

Key Highlights

- dosageAssist
- iQdrive
- Aqua-Sensor, Load-Sensor
- varioSpeed Plus
- varioFlex basket system

Design & Innovation

- Detergent Automation
- Heat exchanger
- Alternating spray technique
- Regenerative electronics
- Inner tub material: Stainless steel/Polinox
- Machine Care Programme
- Self-cleaning filter system with 3-fold corrugated filter
- Electronic delay timer: 1-24 hours
- LED salt refill indicator
- LED rinse aid refill indicator
- VarioFlex basket system
- VarioDrawer
- RackMatic height-adjustable top basket (3 stage)
- 2 foldable plate racks in top basket
- 4 foldable plate racks in bottom basket
- 2 cup shelves in top basket
- AquaStop with guarantee
- Childproof door lock
- Childproof control lock

Programmes

- 6 programmes: Intensive 70 °C, Auto 45-65 °C, Eco 50 °C, Glass 40 °C, 1h 65 °C, Pre Rinse
- 3 special options: VarioSpeed Plus, Intensive Zone, Extra Dry

Technical information

- Energy efficiency class: A++
- Energy consumption in Program Eco 50: 0.92 kwh
- Water consumption in Program Eco 50: 9.5 l
- Noise level: 46 dB
- Product dimensions (HxWxD): 81.5 x 59.8 x 57.3 cm

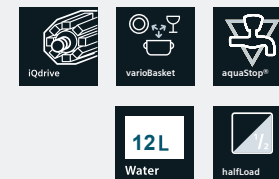

Dishwasher

SN615X00EE

60 cm, Fully integrated, 13 place settings

Key highlights

- iQdrive
- Aqua-Sensor, Load-Sensor
- Acoustic end of cycle indicator
- infoLight
- varioSpeed

Design & Innovation

- dosageAssist
- Energy efficiency class: A+
- Self-cleaning filter system with 3-fold corrugated filter
- LED programme status indicator
- Electronic delay timer: 3, 6 or 9 hours
- LED salt refill indicator
- LED rinse aid refill indicator
- Vario basket system
- VarioDrawer
- Silver XXL baskets
- rackMatic height-adjustable top basket (3 stage)
- 2 foldable plate racks in bottom basket
- 2 cup shelves in top basket
- Glass care protection system
- Childproof door lock

Programmes

- 5 programmes: Intensive 70 °C, Auto 45-65 °C, Eco 50 °C, 1h 65 °C, Pre Rinse
- 1 special option: VarioSpeed

Technical information

- Energy efficiency class: A+
- Energy consumption in Program Eco 50: 1.03 kwh*
- Water consumption in Program Eco 50: 11.7 l*
- Noise level: 48 dB
- Product dimensions (HxWxD): 81.5 x 59.8 x 55 cm



*Energy and water consumption of the standard Eco 50°C programme: Actual consumption value will depend on how the appliance is used. Important information (applicable for all models): Water pressure of 1 to 10 bar and 15 A plug point are pre-requisite.

*Energy and water consumption of the standard Eco 50°C programme: Actual consumption value will depend on how the appliance is used. Important information (applicable for all models): Water pressure of 1 to 10 bar and 15 A plug point are pre-requisite.

*Energy and water consumption of the standard Eco 50 C programme: Actual consumption value will depend on how the appliance is used. Important information (applicable for all models): Water pressure of 1 to 10 bar and 15 A plug point are pre-requisite.

Refrigerators

The choice of the connoisseurs.

Connoisseurs know that different food have hugely different storage requirements. Some require that little bit longer to mature, while others prefer a particularly cool environment. Prized beverages should be stored at a constant temperature and brought precisely up to drinking temperature.

In order to meet the highest demands at Siemens, we develop the professional-grade refrigerators for the new professional domestic kitchens. With over the years of experience, we do this with unparalleled quality and perfection. In doing so, we use materials and techniques that have proven their outstanding quality over decades and draw on our long history of innovation.



The extraordinary Siemens refrigerator.

We at Siemens believe in innovating and developing new technologies as an integral part of our tradition. We have innovations such as fridges that can be controlled according to 4 climate zones to the exact degree, smart technology that ensures the stored fruits and vegetables are fresh and doesn't get affected by the extreme outside temperature, refrigerators that maintain cooling close to 0 degree emulating the modern day refrigeration units.

Our best-known freshness innovations include freshSense, vitaFresh Plus, freshProtectbox. These are known to keep your food fresh at all given time. It's our endeavour to provide products that are not only technically advanced but aesthetically most appealing too. A reason why, our designers focus on creating simple and minimalistic solutions worldwide. The outcome of this is a range of refrigerators that are both functional and modern and provides the coolest kitchen experience.



Refrigerators that make a difference.

A refrigerator functions throughout the day, 365 days a year. Thus, it is worthwhile to choose a refrigerator that offers best energy efficiency. It is our endeavour at Siemens to create products that are high in quality, efficiency and performance. Our appliances are at the top of EU energy saving classifications. In fact some even surpass this benchmark.



Climate class.

Refrigeration works by drawing the warmth out of food stored in the appliance and passing it back into the room. Because of this it is important for refrigerator to be used in the climate range for which it is designed. the climate classes are as below

This is true for all brands in Built-in Range.

SN: 10 – 32° C

N:16 – 32° C

ST: 16 – 38° C

T: 16 – 43° C

To ensure that the refrigerator operates efficiently and economically make sure that the room in which it is installed is within the temperature range specified for its climate class.

Note: Features will vary from product-to-product. Please refer to individual product specification for full details.

The cooling system with multiple possible combinations.

The Siemens aCool & coolConcept series of refrigerators provide all the benefits of a modern food storage system required by you for your lifestyle. The various fully-integral cooling appliances, including wine climate cabinets, can be combined in various ways to form an elegant cooling section in your kitchen in line with your requirement. Multiple combinations such as French Door, Fridge-Freezers, Fridge-Freezer-Wine Cooler, Four-Door, Three-Door, Bottom Freezer, Under Counter Fridge-Freezer, allow you to customize designs to suit your individual taste and needs.



French Door

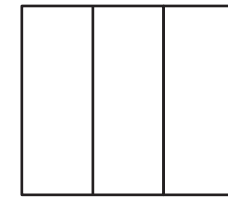

SXS with wine cooler

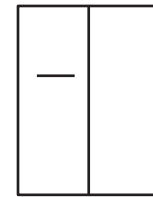

SXS with IWD

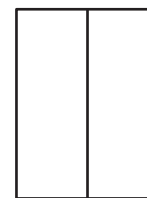

SXS

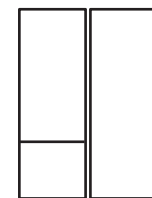

3 Door



4 Door



Tried and tested for a lifetime.

All Siemens refrigerator appliances are built to last. Every single one of our appliances is rigorously tested before it leaves the factory, ensuring that our products meet all the requirements & more of our customers for a long period of time. For 24 hours a day, our components are tested continuously to the maximum tolerance possible for the equivalent lifetime of the appliance. The doors are then opened and closed by the handle 200,000* times during testing to ensure they are robust. Materials are not only tested for suitability and longevity, we also look at how they sound and feel when we use them. Even down to a satisfying door closing action.

Good cooking begins with freshest ingredient.

There's nothing worse than stocking your fridge with full of fresh food, only to find that a few days later it is no longer edible. Saving you time and money Siemens fridge freezer features new technology that is going to prolong the life of your fresh produce, meaning there will be fewer trips to the supermarket so you can enjoy your favorite foods for longer.

These benefits include; keeping your food at the correct temperature, locking in the nutrients with our innovative freshProtectbox, vitaFresh drawer, hydroFresh drawer, and the airFresh filter that helps to separate the smells in your fridge which means no cross contamination between sweet and savory foods. A Siemens fridge freezer is the smartest way to preserve your food.



freshSense

Your fridge door is the most frequented door in your home. This can affect the shelf life of a food product. The challenge here is to maintain a consistent and controlled environment despite ongoing changes. freshSense, a combination of temperature sensors with smart electronics and variable-speed fans creates a controlled environment and optimum temperature. It monitors your style of using the fridge and adjusts accordingly to maintain a stable and even temperature.



freshProtect Box

The freshProtectbox is the luxury suite in your refrigerator. You can set the temperature in the box completely independent from the rest of the refrigerator to 3°C, 1.5°C or 0°C.



vitaFresh Plus (HyperFresh)

Your fresh food can now last twice as long as it would than in a standard vegetable drawer with the Siemens hyperFresh drawer. With an innovative humidity control feature, the drawer retains minerals and nutrients from your vegetables, salads and fruits, increasing their durability by 2X longer.



vitaFresh (CrisperBox)

vitaFresh drawer is the expert of food preservation. The vegetable drawer is equipped with a humidity control system that provides the flexibility to change humidity levels and offers ideal storage conditions for fruits and vegetables.



coolBox

Ideal for storing meat and fish, the coolBox creates an environment that is almost 3°C which is cooler than the rest of the fridge. The coolBox stores meat and fish at the optimum preservation temperature, whilst allowing other food in the fridge to be chilled at around 4°C.



airFresh Filter

The airFresh filter separates the odours, ensuring that the fridge smells fresh at all times. The filter neutralises odours in the fridge, ensuring that different smells don't transfer between foods, while the anti-microbial filter stops the transfer of germs and bacteria.

*Feature will vary from product to product. Please refer to individual product specification for full details.

Good cooking begins with good cooling.

When it comes to refrigerators there is lot more to the word 'cooling' than we know. Keeping your food & other items at the correct temperature requires a sophisticated ecosystem. Trust Siemens refrigerators to know the best condition for your fresh fruits, vegetables and other products that require refrigeration.

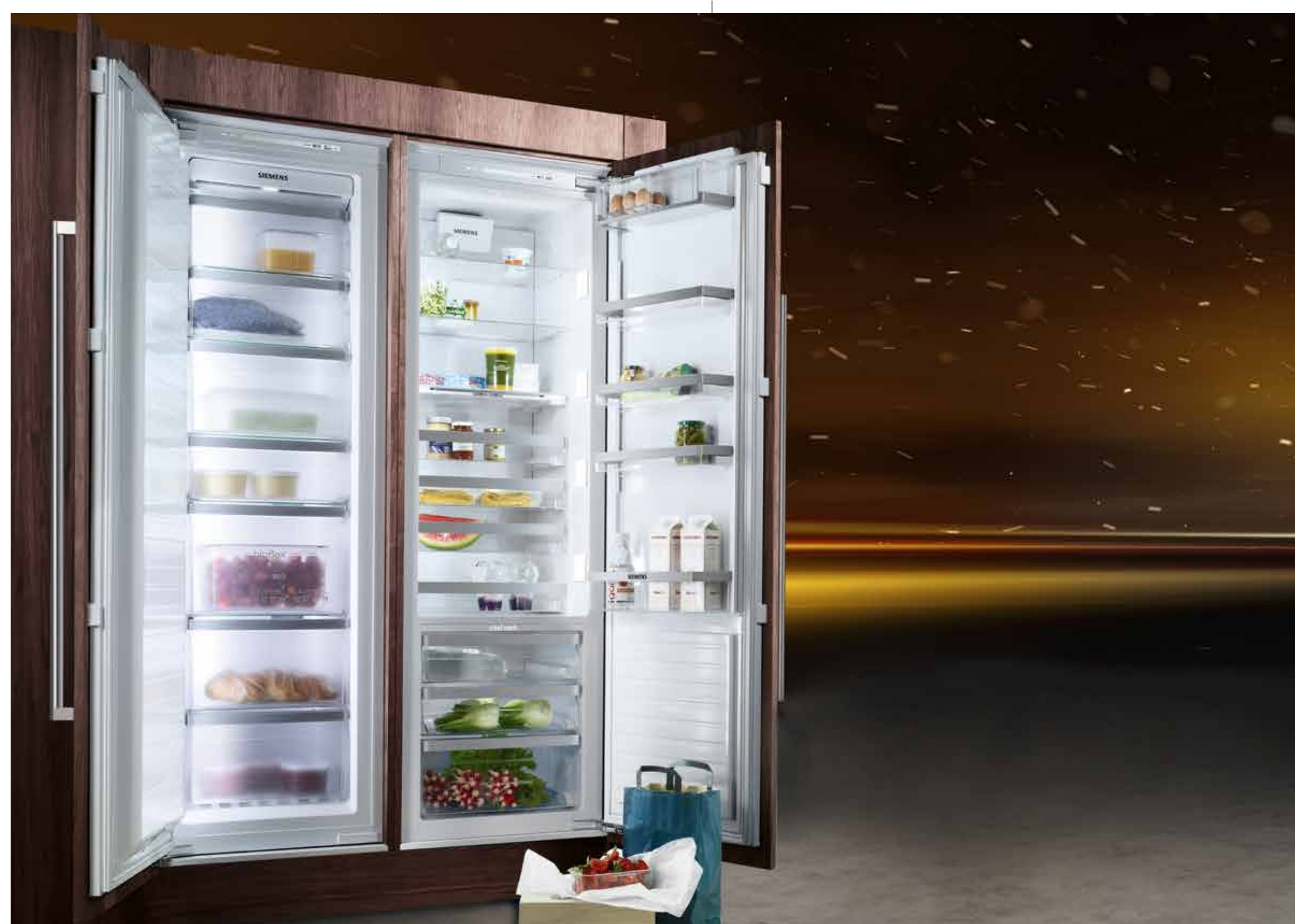

2 cooling system

The Siemens 2 Cooling System compartments ensures constant even temperatures and ideal humidity. Fridge and Freezer compartments are powered by separate cooling circuits with individual temperature controls using 2 evaporator. The cold air is hence not shared between the freezer and the fridge.



Ice Water Dispenser

The freezer's water and ice dispenser provides cold water and ice cubes as well as crushed ice for a drink at the touch of a button. The ice-maker inside the unit can also produce up to 2.5kg of ice cubes in 24 hours.



multiAirflow-System

The multiAirflow-System in the refrigerator ensures that cold air is distributed evenly throughout the interior and along the inside of the door. This keeps the temperature constant, even if the door is accidentally left open for a short period of time.



bigBox

The extra-large freezer space, The bigBox is 27cm high so you can stack several pizzas, or put large freezer containers in the spacious bigBox with ease. There's even enough room for pre-filled dessert glasses.



superCooling and superFreezing

The superCooling and superFreezing functions prevent increase in internal temperatures that can result from adding new contents to the fridge and freezer respectively. This ensures existing contents are uncompromised. Once an even temperature within the fridge or freezer is re-established, the system will automatically reset to normal cooling or freezing status.



superCooling

*Feature will vary from product to product. Please refer to individual product specification for full details.

Convenience a luxury that comes standard with Siemens.

Uninterrupted wide-open spaces and numerous shelving options enable easy customization for different uses. Quality extension runners allow you to slide out storage bins and trays fully for easy loading and unloading. The storage bins are removable, making food preparation and cleaning easier. With a digital display that keeps consumers informed of the precise temperature and helps navigate easily through the operating menus, a door sensor that sets off a warning alarm if the door is left open for any reason; aCool appliances from Siemens feature top of the range technologies. Seamlessly integrated into the sidewall of the fridge for maximum illumination and no loss of fridge space, the LED lighting is both energy efficient and practical.



Fully extendable drawers on telescopic rails

The drawer in the fridge section can be easily pulled out completely and gives a better overview of the refrigerated food. This is ideal because nothing can fall out while getting food items stored at the back of the refrigerator even when stacked fully.



Electronic controls

The digital display allows you to set the precise temperature and helps you to navigate easily through the operating menus. A door status sensor sets off an optical and acoustic warning alarm if the door is left open for any reason. The eco mode helps you to save energy, whilst the vacation setting keeps your items cooled or frozen while you are away for longer periods.



Brilliant illumination with LED

Bright, long-life and maintenance-free LED lights are integrated in to the side walls. With the light aimed slightly towards the rear, the light neither shines directly into your eyes, nor can be blocked by objects stored in your refrigerator.



softClosing door system

The hinges include a special damping system so that when you push the door, it closes gently yet firmly, with no sudden "clunk". And you can walk away with absolute confidence, because the softClosing system will also automatically ensure that the door always closes, completely and securely. With this, even heavier furniture doors are smooth and easy to open and close.



easyLift shelves

Expect nothing but convenience with easyLift shelves. Even when full, you can raise or lower the shelf by 6cm to make room for taller items – ideal for serving jugs. The height-adjustable easyLift glass fridge shelf lets you organize storage space quickly and easily, in a way that flexibly meet your needs. The shelf can be raised or lowered by 6cm with one hand - even when fully loaded. The refrigerator door shelves too are adjustable, sliding smoothly and effortlessly up or down as required and without having to unload the contents first.

varioShelf

The varioShelf consists of two separate 14-cm deep storage shelves and the front shelf can be positioned separately to meet individual storage needs. Positioned one behind the other, the two parts form a whole storage shelf. By sliding the front glass shelf under the back shelf, you can create space in front for particularly tall items, like open bottles or jars.

Storage for anything and everything

For bottles stored in the door, there is a handy bottle storage support that prevents them from rocking moving and tipping over when the door is opened or closed. The versatile pull-out fridge tray in certain models can be positioned at any shelf level and is suitable for storing cold cuts, cheese and other small items.

Acoustic door warning signal

The acoustic door warning signal ensures you're in control. The acoustic door open warning signal alerts you if the door has been left ajar, or if there is no power getting to the fridge. Both energy and wine are safe from being needlessly wasted, saving you money.

*Available in selected models only.

The professional wine storage system.

A perfect addition to our refrigeration appliances, is our full height aCool wine cabinet stores up to 98 bottles whilst adding glamour and individuality to your kitchen.



Dual temperature zones

With the dual temperature zones, your wines can be stored under the best possible conditions. For example, you can keep your white wines in the lower temperature zone, while increasing the temperature in the upper zone for your delicate reds. The LED lighting system is strategically positioned to display your wine to perfection without affecting the internal temperature, and because airFresh filters keep the air inside fresh, your treasured wines won't absorb any unwanted odours.

UV filter

The glass door with integrated UV filter. The aCool vinoThek will always give you an unobstructed view of your fine wines. And to ensure that your wines won't be damaged by harmful UV radiation on sunny days, the aCool vinoThek's glass door is equipped with a UV filter.

Fully extendable shelves

With 14 shelves and seven bottles per shelf, your vinoThek can cradle 98 bottles of wine. To ensure that you can easily access and inspect each and every one of them, every shelf, with the exception of the two fixed in place to distinguish the cooling zones, rest on a smooth-sliding rail system, making them easy to extend as required.

Fridge

CI30RP01

75cm | Gross capacity: 547l

General Information

- Acoustic open door warning system
- Eco-mode
- Holiday mode
- Digital electronic control
- Language setting at the display
- Complete ventilation through plinth
- Variable plinth adaption to go from 10.2 to 18.1cm
- Door aperture angle 115°
- Integrable, flat hinge
- noFrost

Fridge Section

- airfreshFilter
- multiAirflow-System
- superCooling
- LED interior light
- freshProtectBox on Telescopic Rails
- 1 transparent drawer on base unit on telescopic rails
- 1 extra deep door shelf, 2 deep door shelves
- 4 safety glass shelves of which 3 are height adjustable
- Dairy compartment sealed

Technical Information

- Net total capacity: 479 l
- Net fridge capacity 4 - 8°C: 413 l
- Door right hinged, reversible
- Connected load: 311W
- Nominal voltage: 220 - 240V
- Climate class: SN-T

Dimensions

- Appliance Dimensions (HxWxD): 212.5cm x 75.6cm x 60.8cm
- Niche Dimension (HxWxD): 213.4cm x 76.2cm x 61cm



Freezer

FI24DP32

60cm | Gross capacity: 359l

General Information

- Acoustic open door warning system
- Alarm for increase in temperature due to power failure
- Holiday mode
- Digital electronic control - with touch control
- Language setting at the display
- Drinking Water Dispenser, Crushed ice, Ice cube, Child lock, On / Off switch, LED light, Anti Klump Ice
- Complete ventilation through plinth
- Variable plinth adaption to go from 10.2 to 18.1cm
- Door aperture angle 115°
- Integrable, flat hinge
- noFrost

Freezer Section

- Automatic ice cube maker
- Super freezing with automatic switch off
- 2 metal containers on telescopic rails
- 4 metal shelves, thereof 2 height adjustable
- 2 door bins, thereof 1 Dairy compartment sealed
- Fixed water connection with hose 2m, 3/4"
- LED interior light

Technical Information

- Net fridge capacity: 306 l
- Storage time in power failure: 14 h
- Connected load: 592W
- Nominal voltage: 220 - 240V
- Left hinge
- Climate class: SN-T

Dimensions

- Appliance Dimensions (HxWxD): 212.5cm x 60.3cm x 60.8cm
- Niche Dimension (HxWxD): 213.4cm x 61cm x 61cm

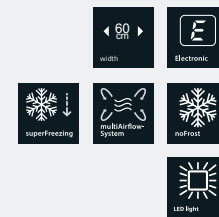

Fridge

CI24RP01

60 cm | Gross capacity: 423l

General Information

- Acoustic open door warning system
- Eco-mode
- Holiday mode
- Digital electronic control
- Language setting at the display
- Complete ventilation through plinth
- Variable plinth adaption to go from 10.2 to 18.1cm
- Door aperture angle 115°
- Integrable, flat hinge
- noFrost

Fridge Section

- airfreshFilter
- multiAirflow-System
- superCooling
- LED interior light
- fresh Protect Box on Telescopic Rails
- 1 transparent drawer on base unit on telescopic rails
- 1 extra deep door shelf, 2 deep door shelves
- Dairy compartment sealed
- Automatic defrost in fridge section

Technical Information

- Net total capacity: 369 l
- Net fridge capacity 4 - 8°C: 318 l
- Door right hinged, reversible
- Connected load: 266W
- Nominal voltage: 220 - 240V
- Climate class: SN-T

Dimensions

- Appliance Dimensions (HxWxD): 212.5cm x 60.3cm x 60.8cm
- Niche Dimension (HxWxD): 213.4cm x 61cm x 61cm



Freezer

FI24NP31

60cm | Gross capacity: 379l

General Information

- Acoustic open door warning system
- Eco-mode
- Holiday mode
- Digital electronic control
- Language setting at the display
- Variable plinth adaption to go from 10.2 to 18.1cm
- Door aperture angle 115°
- Integrable, flat hinge
- noFrost

Freezer Section

- Automatic ice cube maker
- Ice cube output approx. 1.4kg / 24 hrs, storage container approx. 1.5kg
- Fixed water connection with hose 2m, 3/4"
- 3 metal shelves, thereof 2 height adjustable
- 2 metal containers on telescopic rails
- 5 door bins, thereof 1 Dairy compartment sealed
- LED interior light

Technical Information

- Net capacity: 324 l
- Storage time in power failure: 17 h
- Door left hinge
- Connected load: 421W
- Nominal voltage: 220 - 240V
- Climate class: SN-T

Dimensions

- Appliance Dimensions (HxWxD): 212.5cm x 60.3cm x 60.8cm
- Niche Dimension (HxWxD): 213.4cm x 61cm x 61cm



Fridge

KI81RAF30

56cm Fridge | Gross capacity: 321l

General Information

- Acoustic open door warning system
- Electronic digital control with Touchcontrol
- freshSense - maintains a constant temperature by intelligent sensor technology
- Automatic defrost in fridge section

Fridge Section

- hydroFresh on telescopic rails with humidity control - keeps fruit and vegetables up to 2 x longer fresh with carbon filter
- superCool function
- Bottle grid
- 7 safety glass shelves (6 height adjustable) of which 1 is varioShelf divisible and can be pushed under
- 2 easyAccess extendable shelf
- 6 door bins, there of 1x dairy compartment
- Auto defrost - intelligent system that automatically defrosts

Technical Information

- Net fridge capacity: 319 l
- Connected load: 90W
- Nominal Voltage: 220 - 240V
- Reversible, Door right hinged
- Climate class: SN-T

Dimensions

- Appliance Dimensions (HxWxD): 177.2cm x 55.8cm x 54.5cm
- Niche Dimension (HxWxD): 177.5cm x 56.0cm x 55.0cm

Accessories

- 2 x egg tray, bottle holder

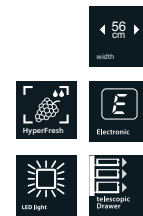

Heating Kit on either side of the refrigerators are mandatory, please ask the Siemens expert for more information.

Freezer

GI81NAE30

56 cm No Frost Freezer | Gross Capacity: 231l

General Information

- noFrost - never again defrosting
- 7 segment electronic control
- Super freezing with automatic switch off
- Acoustic Warning System, Warning System by temperature increase

Freezer Section

- 5 transparent freezer drawers
- Vario Zone - removable safety glass shelves for extra space
- Storage time in power failure: 22 h
- Calendar frozen food

Technical Information

- Net Freezer Capacity: 211 l
- Connected load
- Nominal voltage: 220-240V
- Reversible, door left hinged
- Climate class: SN-T

Dimensions

- Appliance Dimensions (H x W x D): 177.2 cm x 55.8 cm x 54.5 cm
- Niche Dimension (H x W x D): 177.5 cm x 56.0 cm x 55.0 cm

Accessories

- 2 x cold accumulator, 1 x ice cube tray

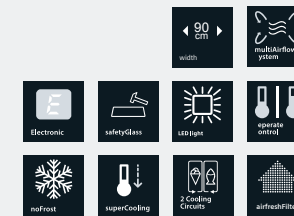

Heating Kit on either side of the refrigerators are mandatory, please ask the Siemens expert for more information.

French Door

CI36BP01

90 cm French Door | Gross capacity: 633l

General Information

- Acoustic open door warning system
- Eco-mode
- Holiday mode
- Digital electronic control
- Language setting at the display
- Variable plinth adaption to go from 10.2 to 18.1cm
- Door aperture angle 115°
- Integrable, flat hinge
- noFrost

Fridge Section

- airFreshFilter
- multiAirflow-System
- superCooling
- LED interior light
- 2 humidity controlled vegetable container on base unit on telescopic rails
- 1 transparent drawer on base unit on telescopic rails
- 2 dairy compartments
- 3 height adjustable safety glass shelves, two on the bottom divided

Freezer Section

- Automatic ice cube maker
- Ice cube storage container ca. 1.5kg
- Freezing capacity: 22kg/24 h
- Super freezing with automatic switch off
- Pantry compartment with additional drawer on base with telescopic rails
- Fixed water connection with hose 2m, 3/4"
- Climate class: SN-T

Technical Information

- Net total capacity: 526 l
- Net fridge capacity 4 - 8°C: 380 l
- Net Freezer capacity: 146 l
- Connected load: 574W
- Nominal voltage: 220 - 240V

Dimensions

- Appliance Dimensions (HxWxD): 212.5cm x 90.8cm x 60.8cm
- Niche Dimension (HxWxD): 213.4cm x 91.4cm x 61cm

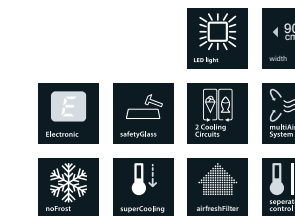

Heating Kit on either side of the refrigerators are mandatory, please ask the Siemens expert for more information.

Bottom Freezer

KI34NP60

55cm Bottom Freezer | Gross capacity: 287l

General Information

- Optical and acoustic door open warning system
- Alarm for increase in temperature due to power failure
- Digital electronic control by TouchControl
- Twin LED electronic control
- softClosing door
- Two cooling systems
- Integrable, flat hinge
- Complete ventilation through plinth
- noFrost

Fridge Section

- superCooling
- Vegetable container ribbed wavy bottom and humidity control on full extended telescopic rails
- 1 divider box
- 3 height adjustable glass shelves
- 4 door bins, thereof 1 extra deep with divider and 3 with easyLift
- Dairy compartment
- LED interior light

Freezer Section

- Super freezing with automatic switch off
- Calendar for frozen food
- 3 transparent freezer drawers, 1 big Box for large food items

Technical Information

- Net total capacity: 259 l
- Storage time in failure: 16h
- Net fridge capacity: 186 l
- Net Freezer capacity: 73 l
- Connected load: 120W
- Nominal voltage: 220-240V
- Door right hinged, reversible
- Climate class: SN-T

Dimensions

- Appliance Dimensions (HxWxD): 177.2cm x 55.6cm x 54.5cm
- Niche Dimension (HxWxD): 177.5cm x 56cm x 55cm

Heating Kit on either side of the refrigerators are mandatory, please ask the Siemens expert for more information.



Freezer

KI187SAF30I*

60cm | Gross capacity: 359l

General Information

- Acoustic open door warning system
- Optical and Acoustic Warning System for temperature increase, with failure memory function
- freshSense - maintains a constant temperature by intelligent sensor technology
- Holiday mode
- Two Cooling systems
- LED Interior light in fridge section
- Interior with metal application

Fridge Section

- superCool function
- hydroFresh Box with humidity control - keeps fruit and vegetables up to 2 x longer fresh
- 5 safety glass shelves (4 height adjustable), of which 1x varioSelf divisible and pushed under shelf, 1 extendable easy Access shelf
- 5 door bins, there of 1x dairy compartment
- Auto defrost - intelligent system that automatically defrosts

Freezer Section

- Super Freezing with automatic switch off
- varioZone - removable safety glass shelves for extra space
- 2 transparent freezer drawers, incl.1 bigBox
- Calendar for frozen food
- Freezing capacity: 7kg in 24h

Technical Information

- Net total capacity: 270 l
- Storage time in failure: 26h
- Net fridge capacity: 209 l
- Net freezer capacity: 61 l
- Connected load: 90W
- Nominal Voltage: 220-240V
- Door right hinged reversible

Dimensions

- Appliance Dimensions (HxWxD): 177.2cm x 55.8cm x 54.5cm
- Niche Dimension (HxWxD): 177.5cm x 56.0cm x 55.0cm

*Projects Exclusive



Fridge

KU15RA50NE

60cm Fridge | Gross capacity: 139l

General Information

- Easy clean interior
- Mechanical control
- Interior with metal applications
- Automatic defrost in fridge section

Fridge Section

- 3 safety glass shelves of which 2 are height adjustable
- Bottle holder in door tray
- Big pull out tray
- 1 vegetable container with lid
- Auto defrost - intelligent system that automatically defrosts

Technical Information

- Net total capacity: 137 l
- connected load: 90W
- Nominal Voltage: 220-240V
- Door right hinged, reversible
- Climate class: SN-T

Dimensions

- Appliance Dimensions (HxWxD): 82.0cm x 59.8cm x 54.8cm
- Niche Dimension (HxWxD): 82.0cm x 60.0cm x 55.0cm

Accessories

- 1 x egg tray

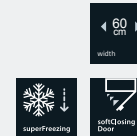

Freezer

GU15DA55

60cm Fully Integrated Freezer | Gross capacity: 114l

General Information

- softClosing Door
- Mechanical control
- Acoustic Warning System, Warning System by temperature increase

Fridge Section

- Super freezing with automatic switch off
- 3 transparent freezer drawers
- Calendar frozen food

Technical Information

- Net total capacity: 98 l
- Storage time in failure: 23h
- Net freezer capacity: 98 l
- Connected load: 90W
- Nominal Voltage: 220-240V
- Door right hinged, reversible
- Climate class: SN-ST

Dimensions

- Appliance Dimensions (HxWxD): 82.0cm x 59.8cm x 54.8cm
- Niche Dimension (HxWxD): 82.0cm x 60.0cm x 55.0cm

Accessories

- 2 x cold accumulator, 1 x ice cube tray



Fridge Freezer

KI18LV52

56cm Fridge | Gross capacity: 137l

General Information

- Easy clean interior
- Mechanical control
- Fully integrated, Flat hinge
- Automatic defrost in fridge section

Fridge Section

- Vegetable container with ribbed bottom
- 3 safety glass shelves of which 2 are height adjustable
- Bottle rack
- 4 large door shelf
- 1 fridge light
- Auto defrost - intelligent system that automatically defrosts

Freezer Section

- 1 hinged freezer compartment
- Ice compartment suited for Pizzas

Technical Information

- Net total capacity: 129 l
- Storage time in failure: 10h
- Net fridge capacity: 112 l
- Net freezer capacity: 17 l
- Connected load: 90W
- Nominal Voltage: 220-240V
- Door right hinged, reversible
- Climate class: ST

Dimensions

- Appliance Dimensions (HxWxD): 87.4cm x 54.1cm x 54.2cm
- Niche Dimension (HxWxD): 88.0cm x 56.0cm x 55.0cm

Accessories

- 1 x egg tray



Wine Cooler

CI24WP02

60cm | Gross capacity: 445l

General Information

- Acoustic open door warning system
- Holiday mode
- Digital electronic control
- Language setting at the display
- Dynamic cooling via integrated fan
- Two separate temperature zones, both continuously variable from 5°C to 18°C
- Glass door
- Metal Innerliner
- Complete ventilation through plinth
- Variable plinth adaption to go from 10.2 to 18.1cm
- Door aperture angle 115°
- Integrable, flat hinge
- Automatic defrost
- Intended to be used exclusively for the storage of wine

Wine Section

- airfreshFilter
- 14 bottle shelves for 98 wine bottles of 0.75 l each
- Two halogen top lights

Technical Information

- Net total capacity: 390 l
- Capacity Wine Storage +6°C to +14°C: 390 l
- Door right hinged, reversible
- Climate class: SN-T

Dimensions

- Appliance Dimensions (HxWxD): 213.4cm x 61cm x 61cm
- Niche Dimensions (HxWxD): 212.5cm x 60.3cm x 60.8cm



Refrigerators - Side-by-Side

Fridge Freezer

KA92DSB30

91cm Free standing Side-by-Side Refrigerator | 636l

Fridge Section

- Multi-airflow system
- 4 safety glass shelves in fridge section of which 3 are height adjustable
- Extendable glass shelf easyLift glass shelf
- Dairy compartment
- 2 large and 3 small door trays in fridge
- Illuminated display

Freezer Section

- 3 Glass, therfor 2 adjustabled
- 2 Partial Extension, incl. 1 Big Box
- 4 door trays in freezer section, removable and fold-away
- In-door ice water dispenser
- Internal LED Lights

Technical Information

- Left hinged door, Right hinged door
- Door-closing aid
- 4 height adjustable feet
- Connection value 190 W
- Nominal voltage: 220 - 240 V

Dimensions

- Dimensions (HxWxD): 175.6 cm x 91 cm x 72.5 cm
- Gross Capacity: 636 L

Accessories

- 2 x cold accumulator, 1 x connection hose, 1 x egg tray

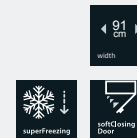

Side-by-Side Refrigerator

KA92NLB35

91cm Free standing Side-by-Side Refrigerator | 655l

Fridge Section

- Multi-airflow system
- AirFreshFilter
- 4 safety glass shelves in fridge section of which 3 are height adjustable
- Extendable glass shelf easyLift glass shelf
- Dairy compartment
- 2 large and 3 small door trays in fridge
- Internal LED lighting in fridge

Freezer Section

- Net Capacity Freezer: 202 L
- Freezing capacity: 12 kg in 24 hours
- 4 Glass, therfor 2 adjustabled
- 2 Partial Extension, incl. 1 Big Box
- 5 door trays in freezer section, removable and fold-away
- Twist ice box
- Internal LED Lights

Technical Information

- Left hinged door, Right hinged door
- Door-closing aid
- 4 height adjustable feet
- Connection value 190 W
- Nominal voltage: 220 - 240 V

Dimensions

- Dimensions (HxWxD): 175.6 cm x 91 cm x 72.5 cm
- Gross Capacity: 655 L

Accessories

- 2 x cold accumulator, 1 x egg tray



Side-by-Side Refrigerator

KA56NV40NE

91cm Free Standing Side-by-Side Refrigerator| 618l

Fridge Section

- Multi-airflow system
- Automatic defrost in fridge section
- 2 Vegetable containers
- 4 Safety glass shelves of which 3 are height adjustable, incl. one extendable shelf
- Dairy compartment
- 2 Interior lights

Freezer Section

- 4 safety glass shelves of which 3 are height adjustable, incl. one extendable shelf
- 2 transparent freezer drawers
- Freezer light
- 2 ice cube trays
- Freezing capacity: 10 kg in 24 h

Technical Information

- Storage time in failure: 5h
- Net fridge capacity: 354l
- Net freezer capacity: 201l
- Connected load: 90W
- Door hinge, left & right

Dimensions

- Dimensions (HxWxD): 180 cm x 90 cm x 67.4 cm
- Gross Capacity: 618 L

Accessories

- 2 x cold accumulator, 1 x egg tray

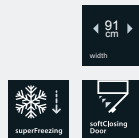

Accessories for Refrigerator and Wine Cooler.

Accessory No.	Description	Accessory for
CI10Z090	Long handle in Stainless Steel	CI24RP01 CI24WP02 CI30RP01 FI24DP02 FI24NP31
CI10Z490	Handle in Stainless Steel for Trio fridge freezer	CI36BP01
CI24Z000	Toe Kick in Stainless Steel (right hinged)	CI24RP01 CI24WP02
CI24Z100	Toe Kick in Stainless Steel (left hinged)	CI24RP01 CI24WP02
CI24Z590	Door panel in Stainless Steel without handle for 24" wine coolers (right hinged)	CI24WP02
CI24Z690	Door panel in Stainless Steel without handle for 24" wine coolers (left hinged)	CI24WP02
CI30Z000	Toe Kick in Stainless Steel for 30" fridges	CI30RP01
CI30Z100	Toe Kick in Stainless Steel for 30" fridges	CI30RP01
CI36Z400	Toe Kick Stainless Steel for 36" Trio fridge freezer	CI36BP01
CI36Z490	Door panel in Stainless Steel for 36" Trio fridge freezer	CI36BP01
FI30Z090	Door panel in Stainless Steel without handle for 30" fridges	CI30RP01

Accessories for Refrigerator and Wine Cooler.

Accessory No.	Description	Accessory for
CI60Z000	Installation Kit SxS	CI24RP01 CI24WP02 CI30RP01 FI24DP02 FI24NP31
CI60Z100	Heating Kit SxS for 230V	CI24RP01 CI24WP02 CI30RP01 CI36BP01 FI24DP02
FI24Z000	Toe Kick in Stainless Steel (right hinged)	FN24NP31
FI24Z090	Door panel in Stainless Steel without handle for 24" fridges (left hinged)	CI24RP01 FI24NP31
FI24Z100	Toe Kick in Stainless Steel (left hinged)	FI24NP31
FI24Z200	Toe Kick in Stainless Steel (right hinged)	FI24DP02
FI24Z290	Door panel in Stainless Steel with cut out for dispenser without handle for 24" freezers	FI24DP02
FI24Z300	Toe Kick in Stainless Steel (left hinged)	FI24DP02 FI24DP31
FI50Z000	Water filter	CI36BP01 FI24DP02 FI24DP31 FI24NP31
11017926	Heating kit	KI34NP60 KI28NP60 KI81RAF30 GI81NAE30

SIEMENS

Product installation guide

siemens-home.bsh-group.com

Siemens Home Appliances



Combination Microwave Oven with pulseSteam

HN678G4S1

60cm Full size Combination Microwave and pulseSteam Oven

Installation with a hob.

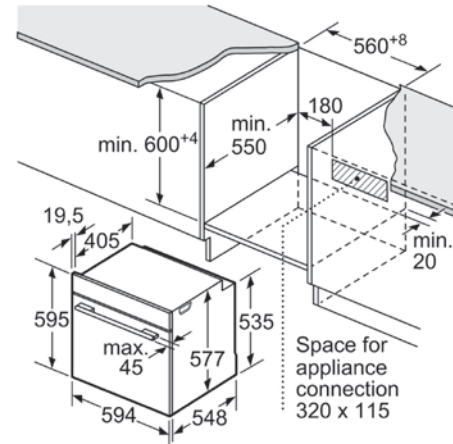
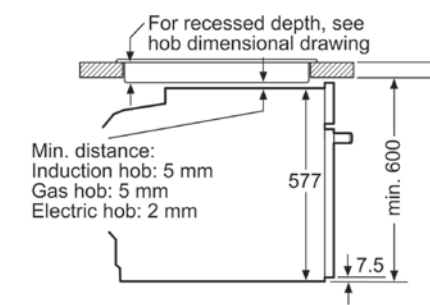

All measurements and dimensions in mm

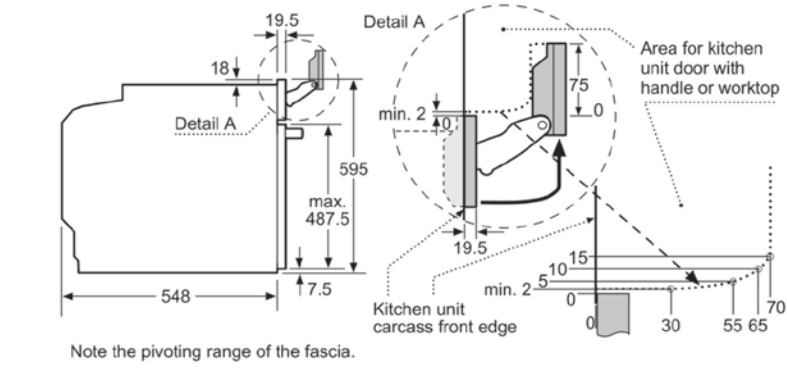

All measurements and dimensions in mm

Combination Steam Oven

HS636GDS1

60cm Full size Combination Steam Oven

Installation with a hob.

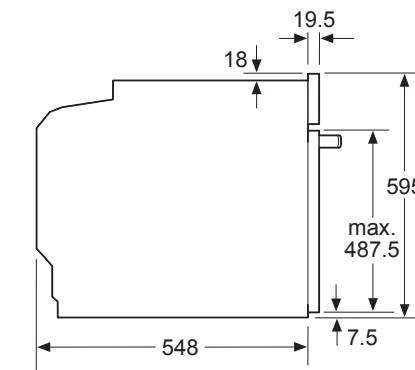
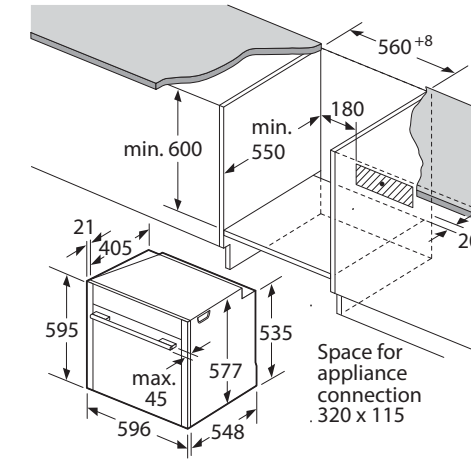
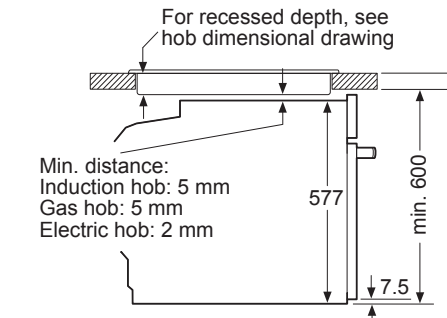

All measurements and dimensions in mm

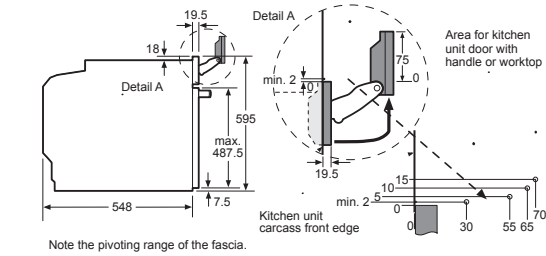

If the appliance will be installed underneath a hob, the following worktop thicknesses (including substructure if necessary) must be taken into account.

Hob type	min. worktop thickness	
	fitted	flush
Induction hob	37 mm	38 mm
Full surface induction hob	43 mm	48 mm
Gas hob	32 mm	42 mm
Electric hob	22 mm	24 mm

All measurements and dimensions in mm

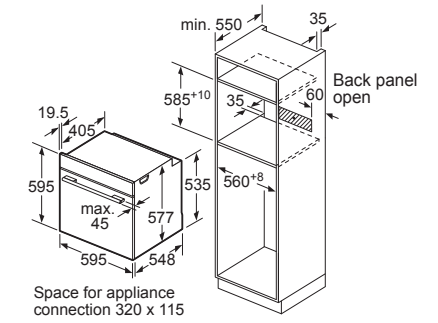

Combination Steam Oven

CS656GBS1

45cm Compact Combination Steam Oven

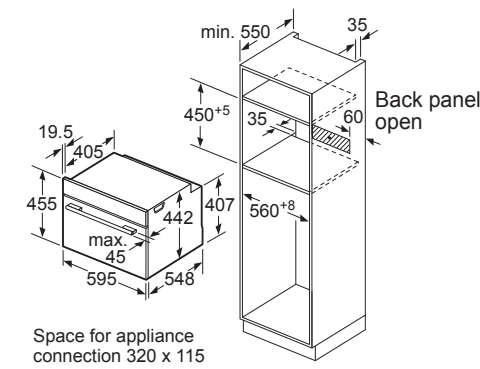
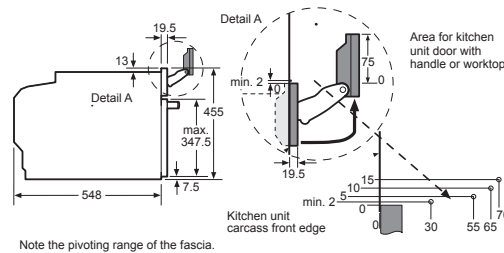
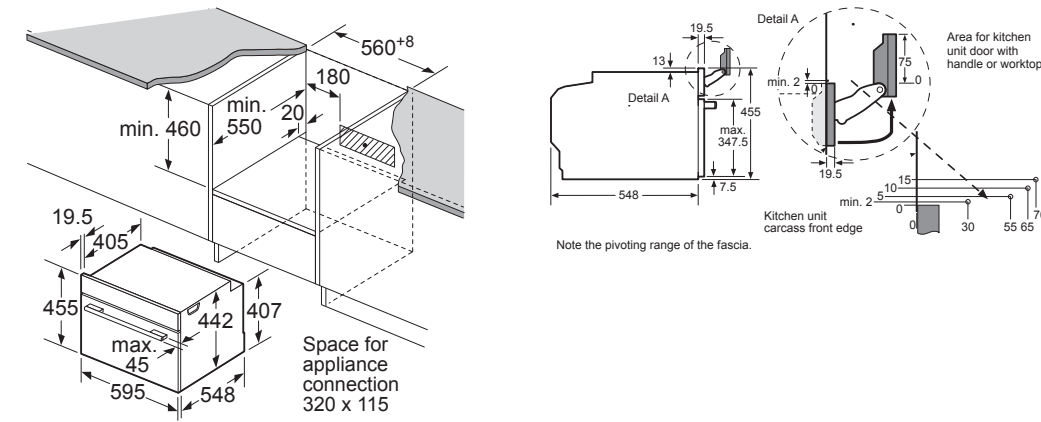

All measurements and dimensions in mm

Installation with a hob.

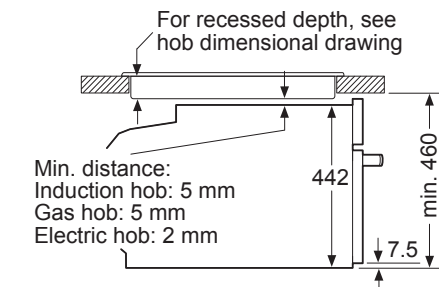

Min. distance:
Induction hob: 5 mm
Gas hob: 5 mm
Electric hob: 2 mm

If the compact appliance will be installed underneath a hob, the following worktop thicknesses (including substructure if necessary) must be taken into account.

Hob type	min. worktop thickness	
	fitted	flush
Induction hob	42 mm	43 mm
Full surface induction hob	48 mm	53 mm
Gas hob	37 mm	47 mm
Electric hob	28 mm	30 mm

All measurements and dimensions in mm

Combination Microwave Oven

HM676G0S1

60cm Full size Combination Steam Oven

Installation with a hob.

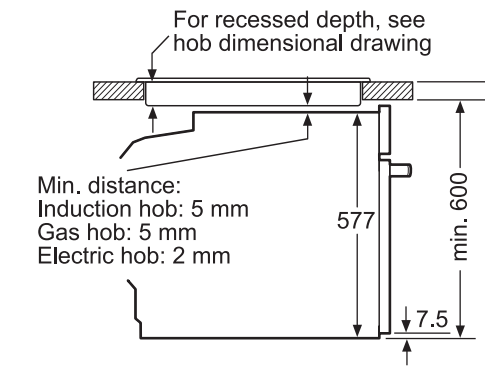

Min. distance:
Induction hob: 5 mm
Gas hob: 5 mm
Electric hob: 2 mm

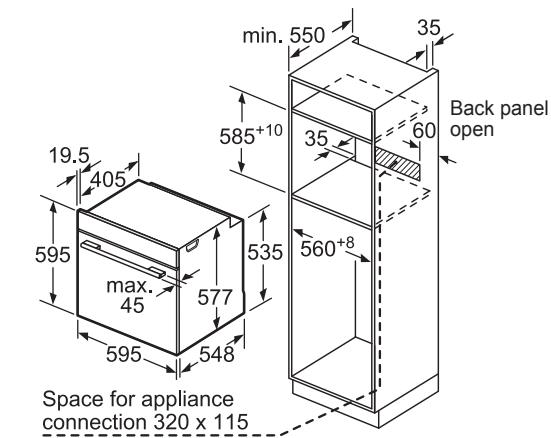
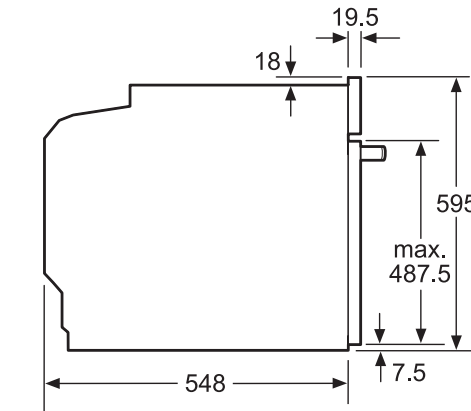

All measurements and dimensions in mm

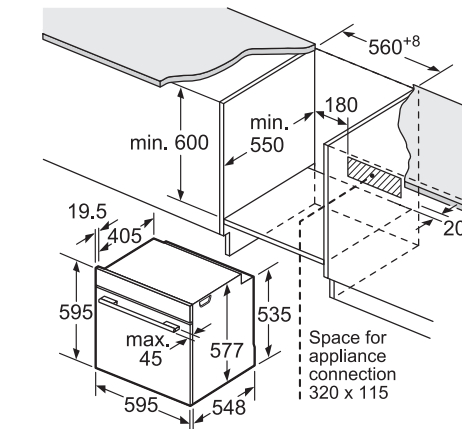

If the appliance will be installed underneath a hob, the following worktop thicknesses (including substructure if necessary) must be taken into account.

Hob type	min. worktop thickness	
	fitted	flush
Induction hob	37 mm	38 mm
Full surface induction hob	43 mm	48 mm
Gas hob	32 mm	42 mm
Electric hob	22 mm	24 mm

All measurements and dimensions in mm

Combination Microwave Oven

CM676GBS1

45cm Compact Combination Steam Oven

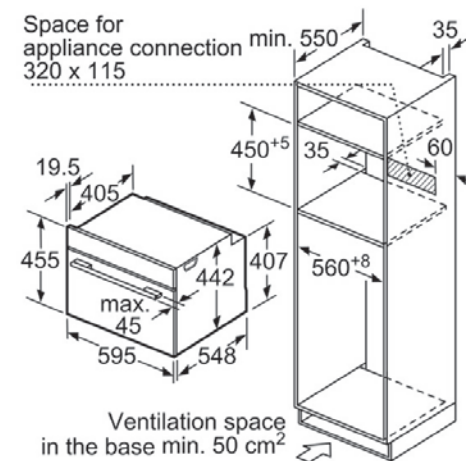
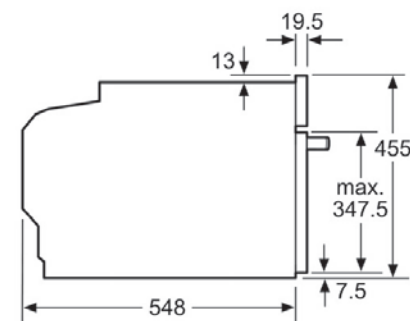
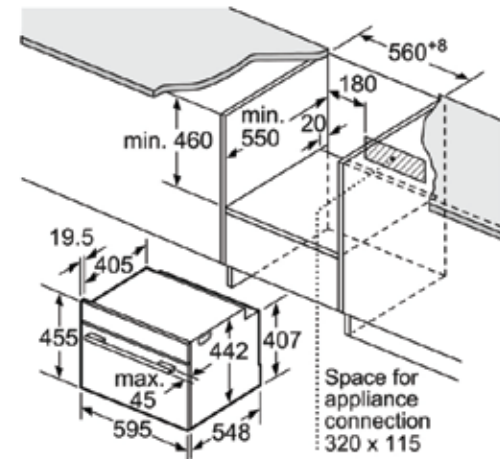

Installation with a hob.

If the compact appliance will be installed underneath a hob, the following worktop thicknesses (including substructure if necessary) must be taken into account.

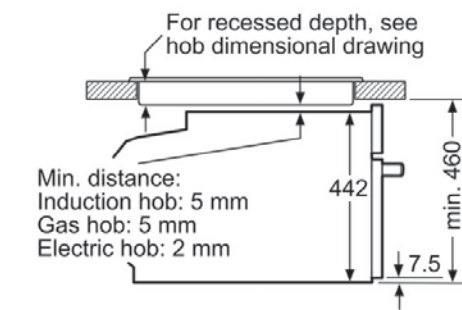

Hob type	min. worktop thickness	
	fitted	flush
Induction hob	42 mm	43 mm
Full surface induction hob	48 mm	53 mm
Gas hob	37 mm	47 mm
Electric hob	28 mm	30 mm

All measurements and dimensions in mm

Oven

HB676G5S1

60cm Single Oven

Installation with a hob.

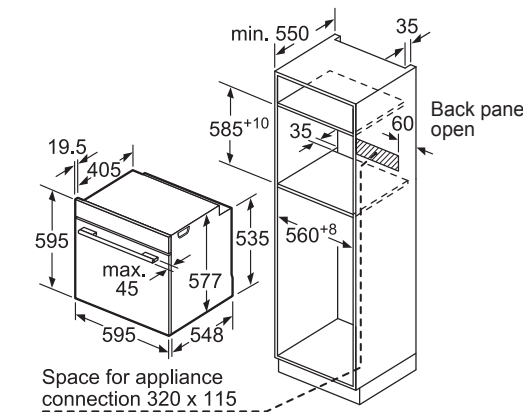
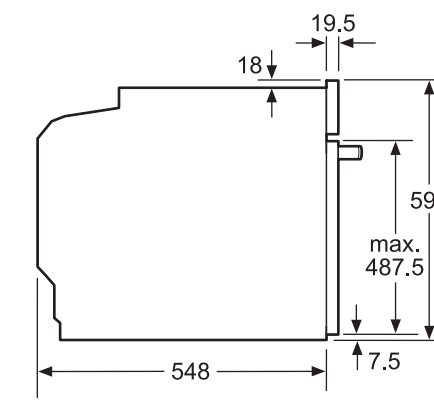
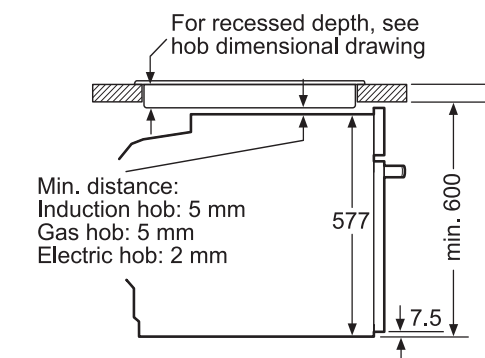

All measurements and dimensions in mm

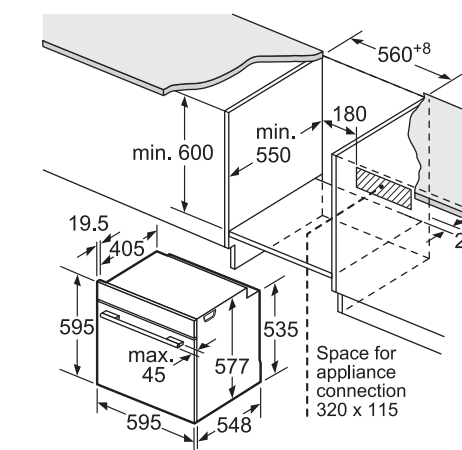

If the appliance will be installed underneath a hob, the following worktop thicknesses (including substructure if necessary) must be taken into account.

Hob type	min. worktop thickness	
	fitted	flush
Induction hob	37 mm	38 mm
Full surface induction hob	43 mm	48 mm
Gas hob	32 mm	42 mm
Electric hob	22 mm	24 mm

All measurements and dimensions in mm

Oven

HB634GBS1 60cm Single Oven

Installation with a hob.

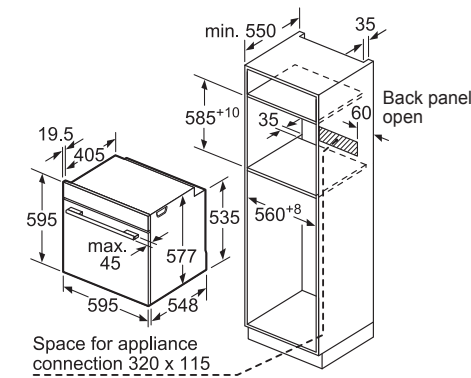
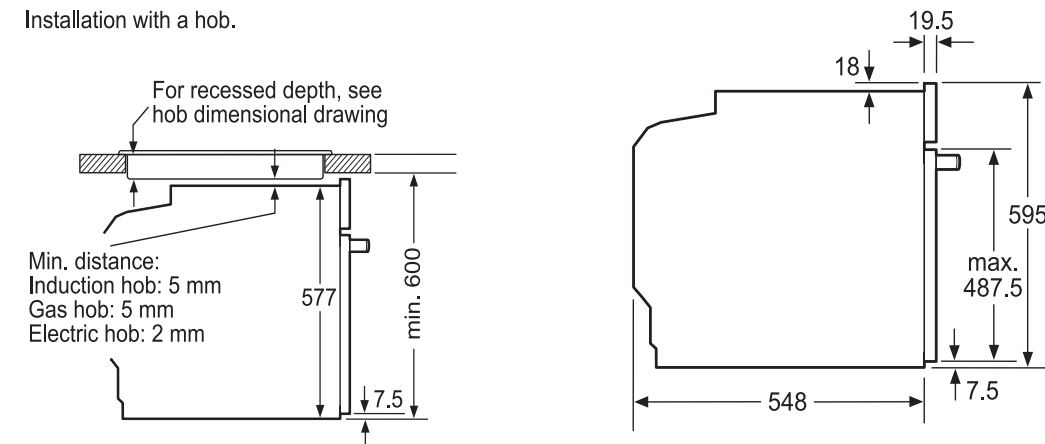

All measurements and dimensions in mm

If the appliance will be installed underneath a hob, the following worktop thicknesses (including substructure if necessary) must be taken into account.

Hob type	min. worktop thickness	
	fitted	flush
Induction hob	37 mm	38 mm
Full surface induction hob	43 mm	48 mm
Gas hob	32 mm	42 mm
Electric hob	22 mm	24 mm

All measurements and dimensions in mm

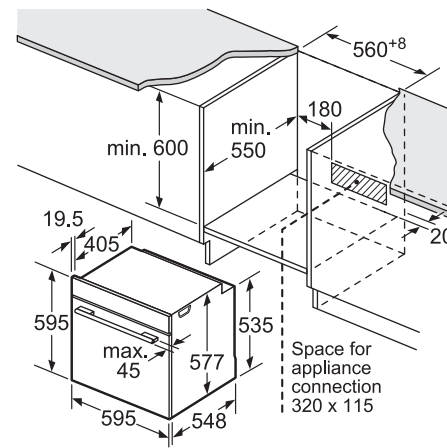

Oven

HB23AB523K 60cm Single Oven

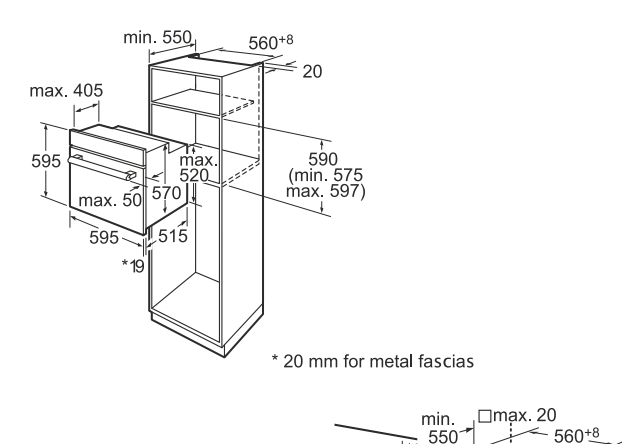

All measurements and dimensions in mm

Microwave Oven

BE634LGS1I 38cm Microwave Oven with Grill

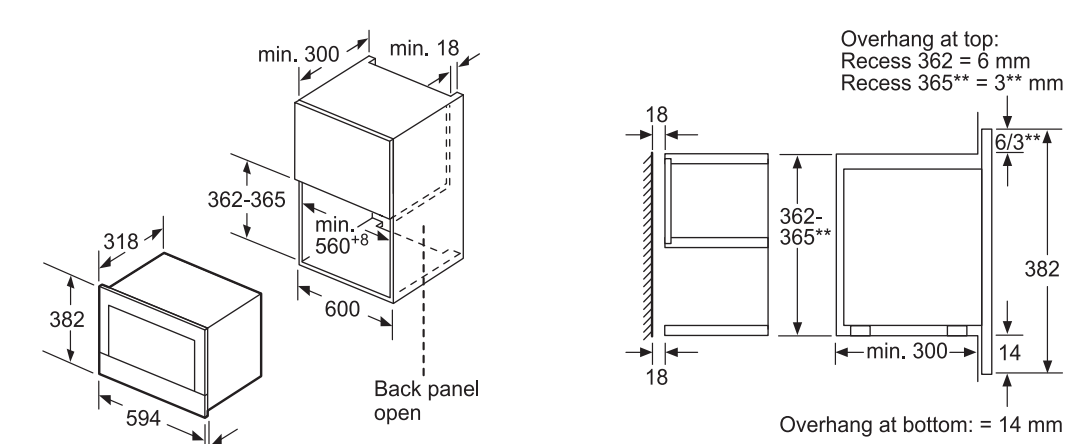

All measurements and dimensions in mm

Microwave Oven

BF634LGS1I 38cm Microwave Oven

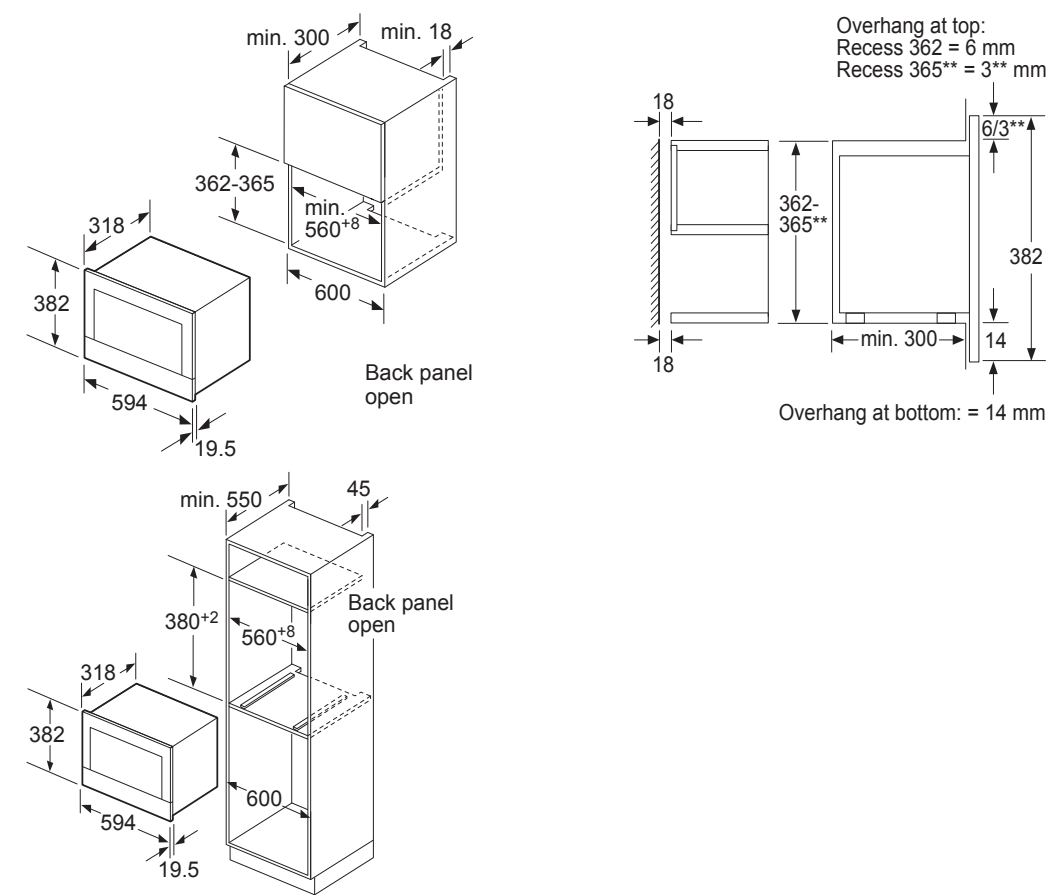

All measurements and dimensions in mm

HF22G564IN 38cm Microwave Oven with Grill

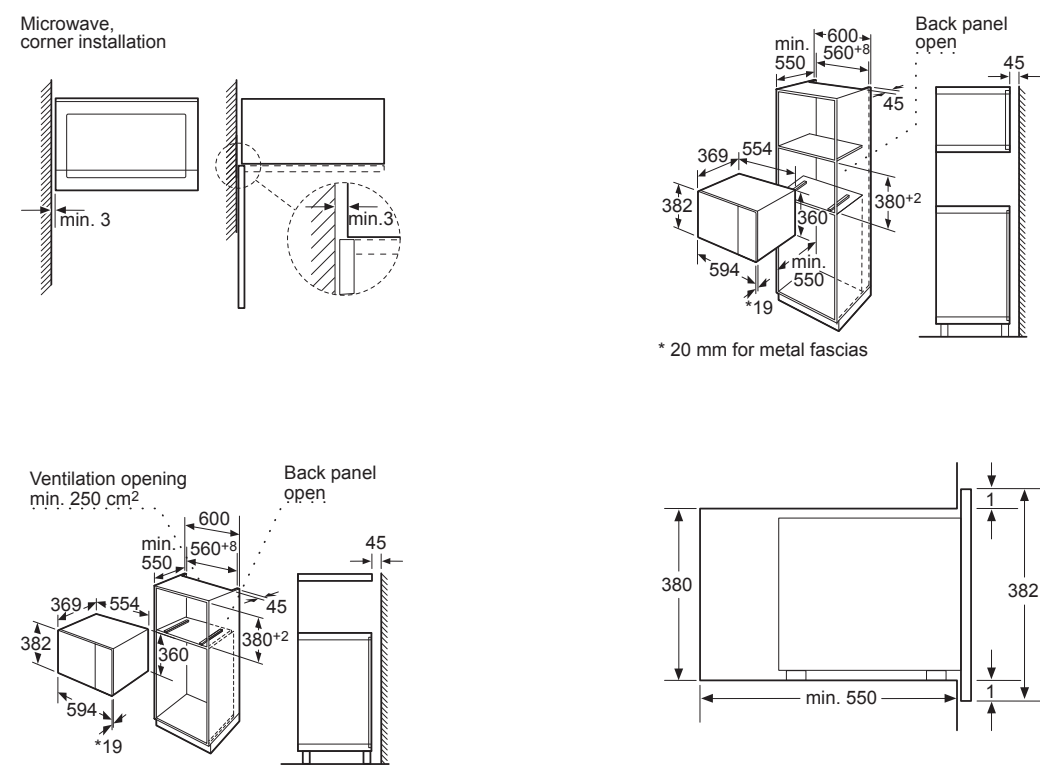

All measurements and dimensions in mm

Gas Hob

ER9A6SD70 90 cm, Ceramic Gas hob

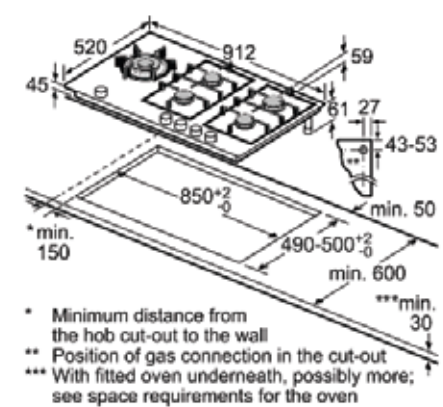

All measurements and dimensions in mm

EC9A5SB90 90 cm, Stainless steel Gas hob

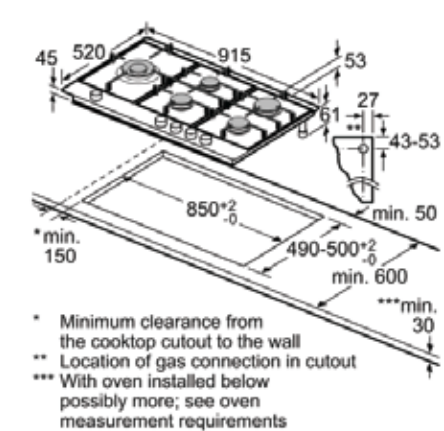

EP9A6QB90 90 cm, Hard Glass Gas hob, Black

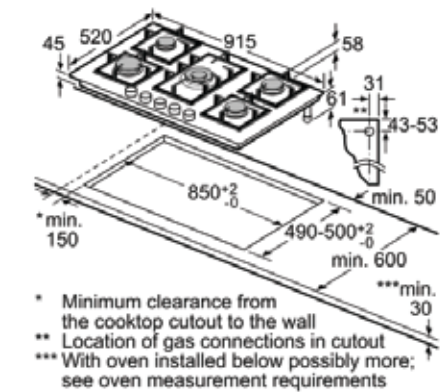

All measurements and dimensions in mm

EC9A5RB90 90 cm, Stainless steel Gas hob

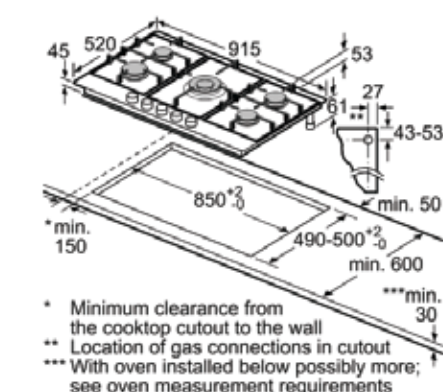

All measurements and dimensions in mm

Gas Hob

EP6A6HB20

60 cm, Hard Glass Gas hob, Black

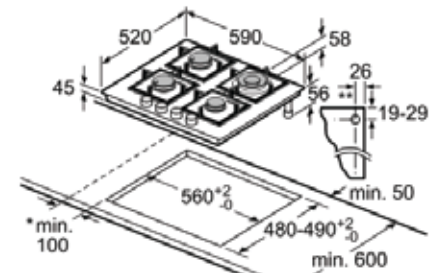

- * Minimum clearance from the cooktop cutout to the wall
- ** Location of gas connections in cutout
- *** With oven installed below possibly more; see oven measurement requirements

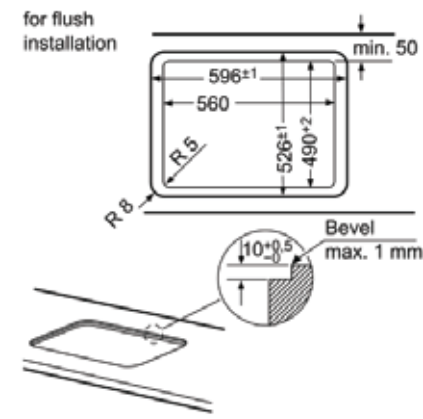

All measurements and dimensions in mm

EC6A5HB90

60cm Tempered Glass Gas Hob

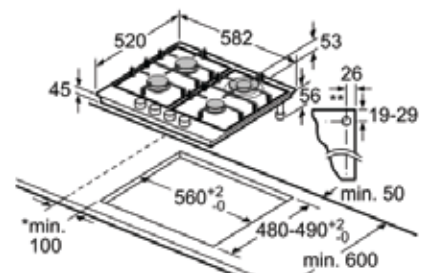

- * Minimum clearance from the cooktop cutout to the wall
- ** Location of gas connection in cutout
- *** With oven installed below possibly more; see oven measurement requirements

ER95331IN

90cm Tempered Glass Gas Hob

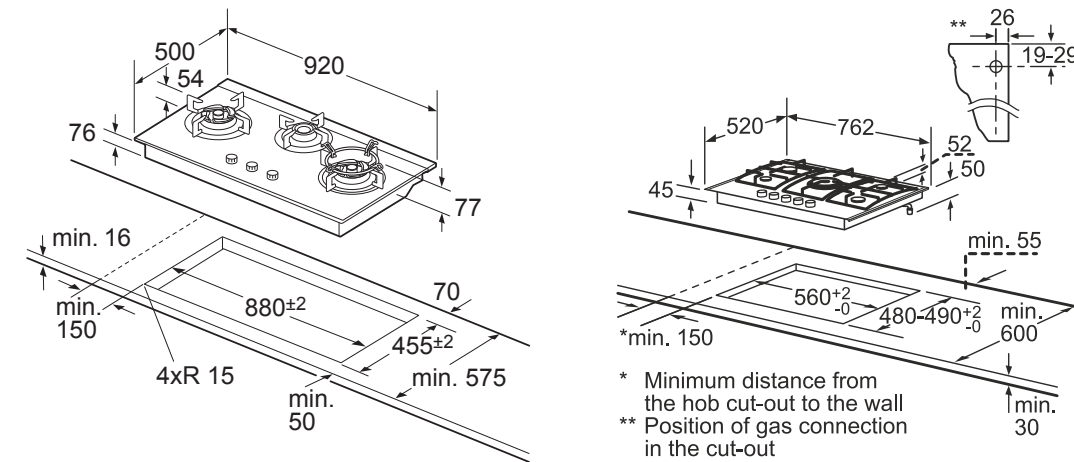

- No drawers should be placed & enough ventilation to be provided in the cabinet below the hob

All measurements and dimensions in mm

EC845IB90E

76cm Stainless Steel Gas Hob

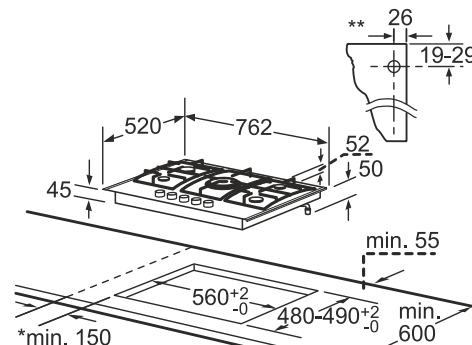

- * Minimum distance from the hob cut-out to the wall
- ** Position of gas connection in the cut-out

Gas Hob

ER3A6BD70

30 cm, Ceramic Gas hob

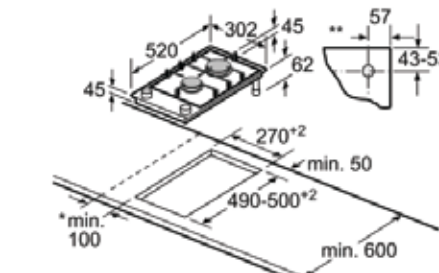

- * Minimum clearance from recessed cooktop cutout to the wall
- ** Location of gas connection (in cutout)
- *** With oven installed below possibly more; see oven measurement requirements

All measurements and dimensions in mm

ER3A6AD70

90cm Stainless Steel Gas Hob

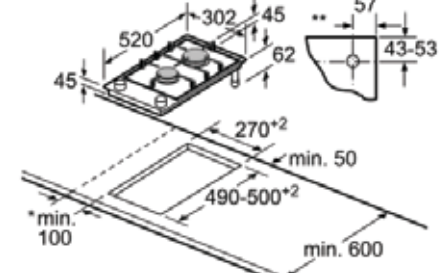

- * Minimum clearance from recessed cooktop cutout to the wall
- ** Location of gas connection (in cutout)
- *** With oven installed below possibly more; see oven measurement requirements

measurements in mm

Domino Barbecue Grill

ET375FUB1E
30cm Barbecue Grill

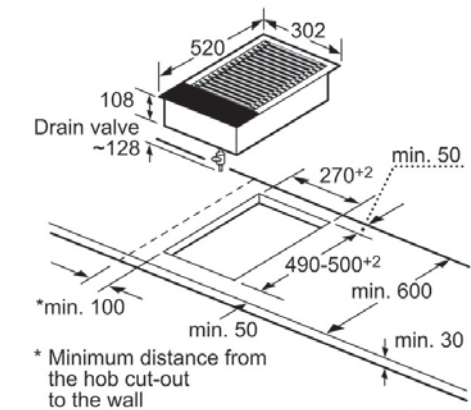

* Minimum distance from the hob cut-out to the wall

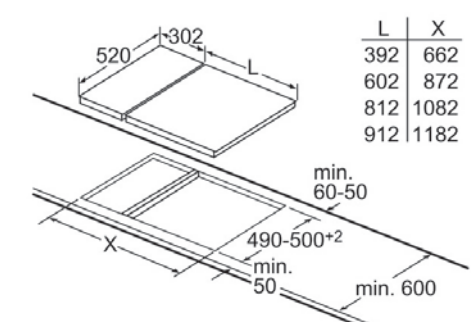

When installing a Domino unit right next to a hob, an assembly kit (HZ394301) is required.

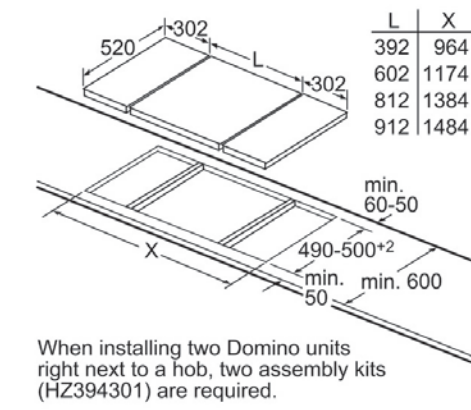

When installing two Domino units right next to a hob, two assembly kits (HZ394301) are required.

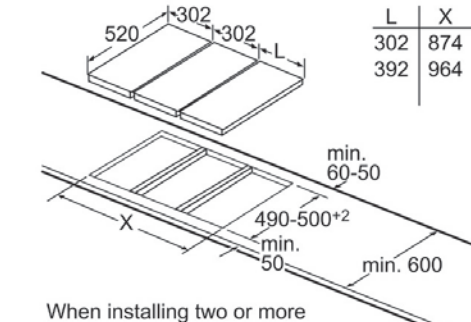

When installing two or more Domino units side-by-side, one or more assembly kits are required (2 units = 1 assembly kit, 3 units = 2 assembly kits, etc.).

All measurements and dimensions in mm

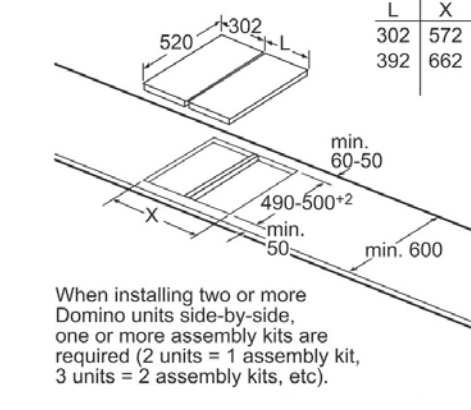

When installing two or more Domino units side-by-side, one or more assembly kits are required (2 units = 1 assembly kit, 3 units = 2 assembly kits, etc.).

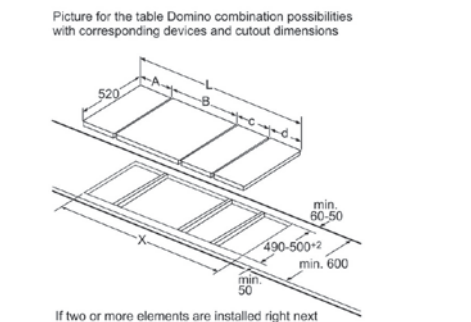

When installing two or more Domino units side-by-side, one or more assembly kits are required (2 units = 1 assembly kit, 3 units = 2 assembly kits, etc.).

All measurements and dimensions in mm

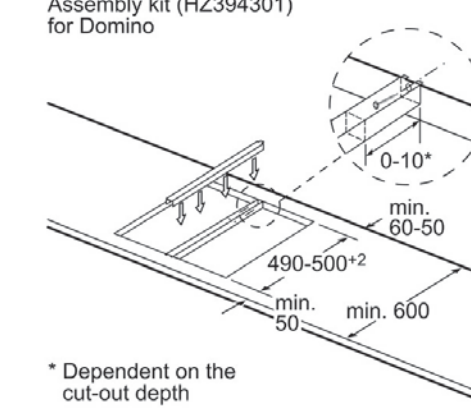

* Dependent on the cut-out depth

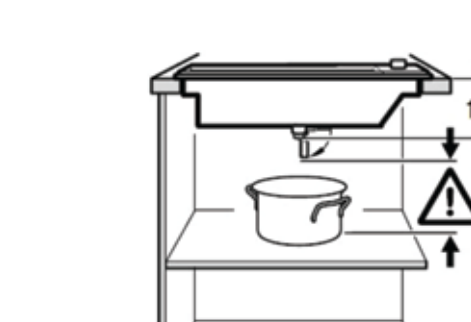

When installing two or more Domino units side-by-side, one or more assembly kits are required (2 units = 1 assembly kit, 3 units = 2 assembly kits, etc.).

All measurements and dimensions in mm

Domino Deep Fryer

ET375FAB1E
30cm Deep Fryer

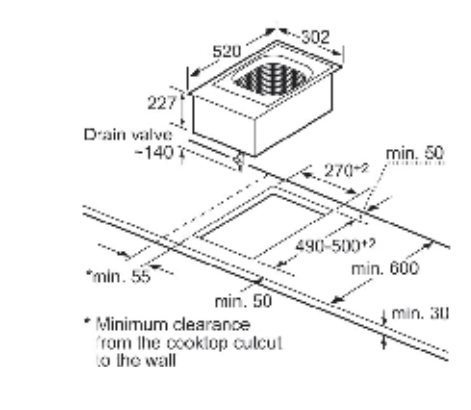

* Minimum clearance from the cooktop cut-out to the wall

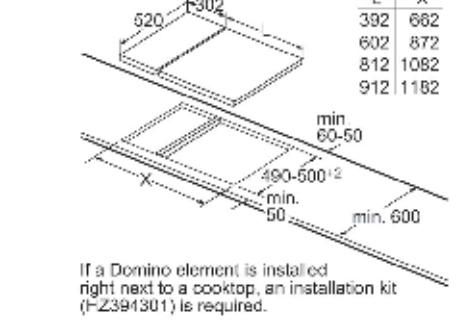

If a Domino element is installed right next to a cooktop, an installation kit (HZ394301) is required.

All measurements and dimensions in mm

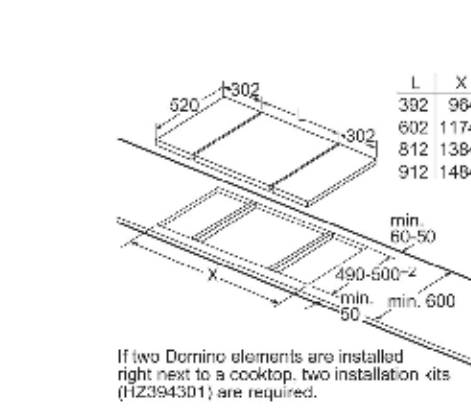

If two Domino elements are installed right next to a cooktop, two installation kits (HZ394301) are required.

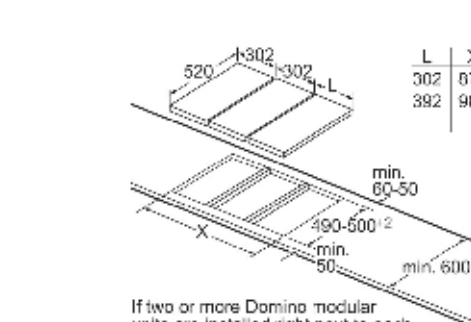

If two or more Domino modular units are installed right next to each other, one or more installation kits are required (2 elements 1 installation kit, 3 elements 2 installation kits, etc.).

All measurements and dimensions in mm

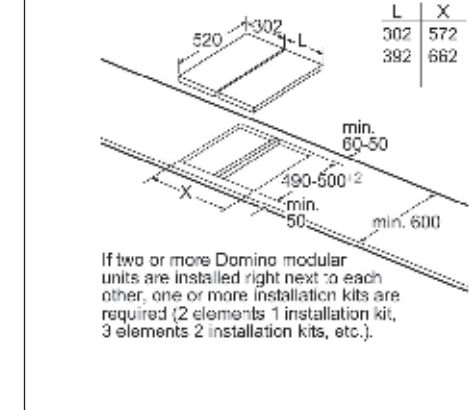

* Depends on the cut-out depth

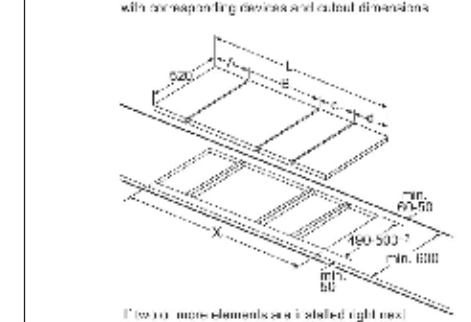

When installing two or more Domino units side-by-side, one or more assembly kits are required (2 units = 1 assembly kit, 3 units = 2 assembly kits, etc.).

All measurements and dimensions in mm

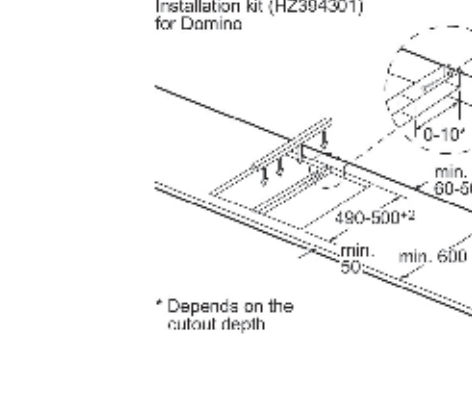

* Depends on the cut-out depth

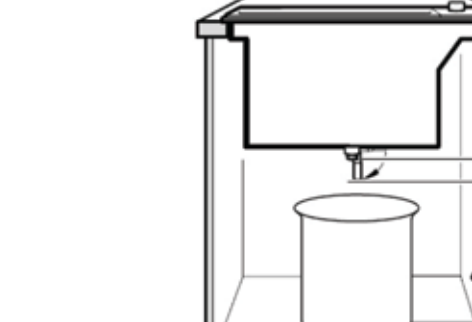

When installing two or more Domino units side-by-side, one or more assembly kits are required (2 units = 1 assembly kit, 3 units = 2 assembly kits, etc.).

All measurements and dimensions in mm

Domino Teppanyaki

ET475FYB1E
40cm Teppan Yaki

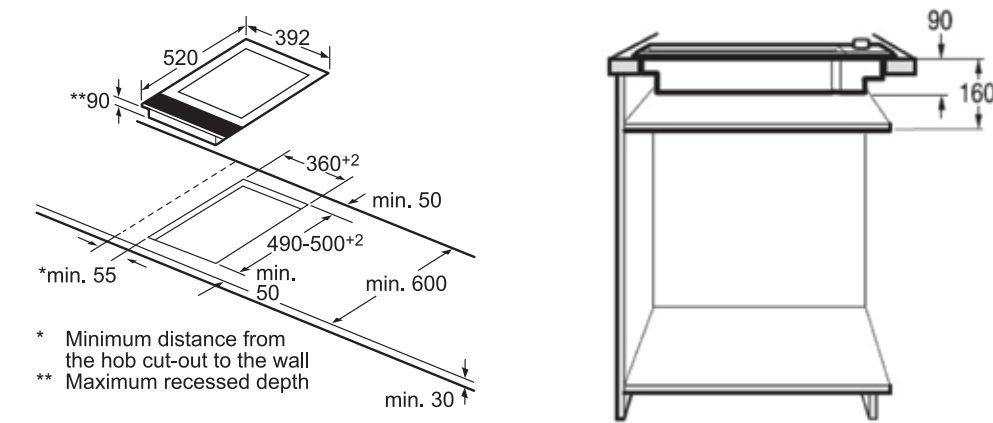

All measurements and dimensions in mm

Domino flexInduction Hob

EX375FXB1E
30cm flexInduction

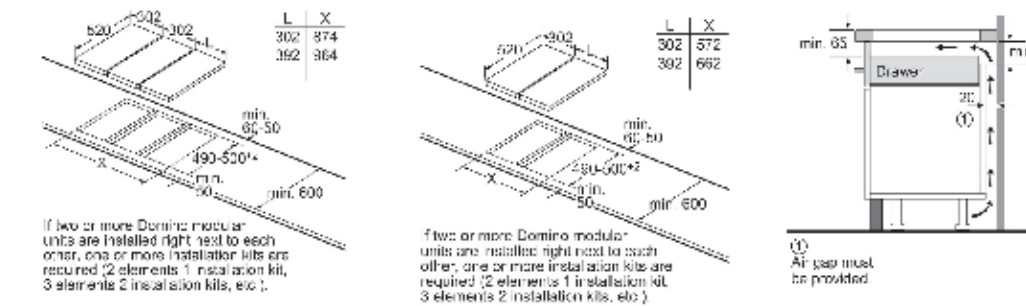
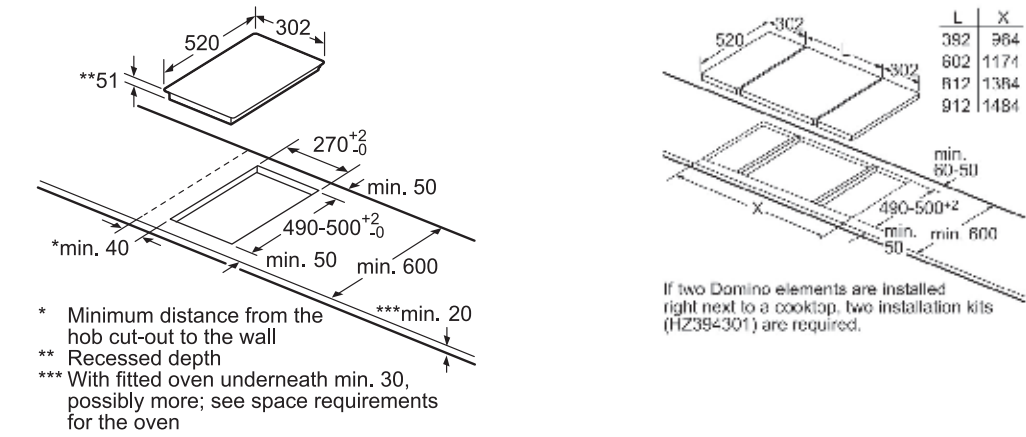

All measurements and dimensions in mm

Domino Cutout Dimension

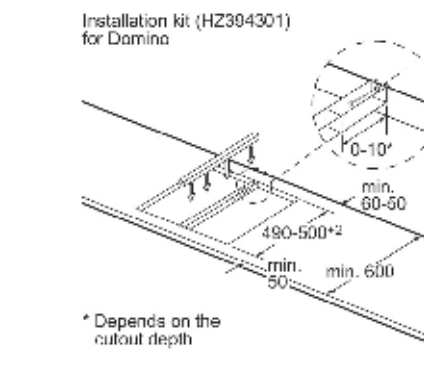

Domino combination possibilities with corresponding device and cutout dimensions

Width type: 30 40 60 70 80 90
Device width: 302 392 602 710 812 912

	A	B	C	D	L	X
2x30	302	302	-	-	604	572
1x30, 1x40	302	392	-	-	694	662
1x30, 1x60	302	602	-	-	904	872
1x30, 1x70	302	710	-	-	1012	980
1x30, 1x80	302	812	-	-	1114	1082
1x30, 1x90	302	912	-	-	1214	1182
2x40	392	392	-	-	784	752
1x40, 1x60	392	602	-	-	994	962
1x40, 1x70	392	710	-	-	1102	1070
1x40, 1x80	392	812	-	-	1204	1172
1x40, 1x90	392	912	-	-	1304	1272
3x30	302	302	302	-	908	874
2x30, 1x40	302	302	392	-	998	964
2x30, 1x60	302	302	602	-	1206	1174
2x30, 1x70	302	302	710	-	1314	1282
2x30, 1x80	302	302	812	-	1416	1384
2x30, 1x90	302	302	912	-	1518	1484
1x30, 2x40	302	392	392	-	1088	1054
1x30, 1x40, 1x60	302	392	602	-	1298	1264
1x30, 1x40, 1x70	302	392	710	-	1404	1372
1x30, 1x40, 1x80	302	392	812	-	1506	1474
1x30, 1x40, 1x90	302	392	912	-	1608	1574
3x40	392	392	392	-	1178	1144
2x40, 1x60	392	392	602	-	1388	1354
4x30	302	302	302	302	1208	1176
3x30, 1x40	302	302	302	392	1298	1266
2x30, 2x40	302	302	392	392	1388	1356
1x30, 3x40	302	392	392	392	1478	1446

All measurements and dimensions in mm

flexInduction Hob

EX675LYC1E 60cm flexInduction Hob

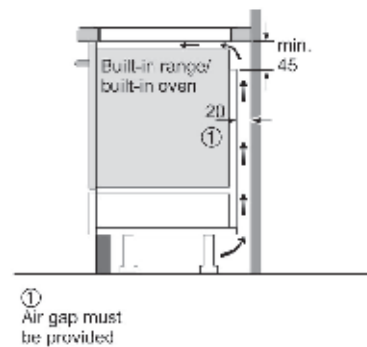
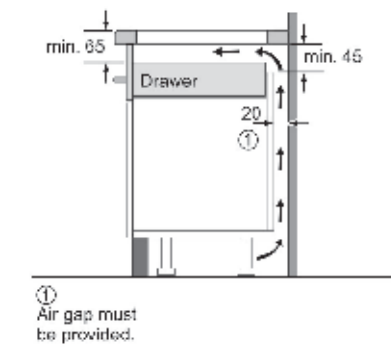
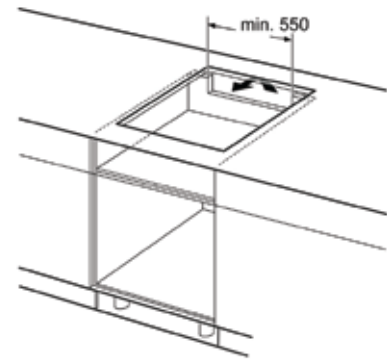
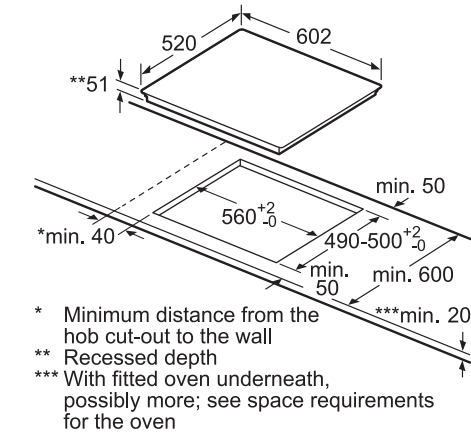

All measurements and dimensions in mm

EX275FXB1E 90cm flexInduction Hob

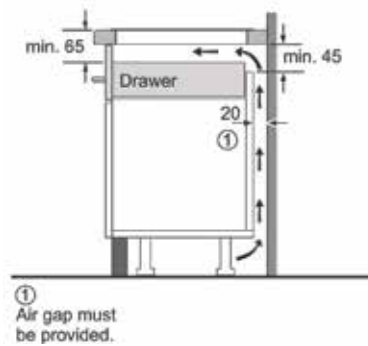
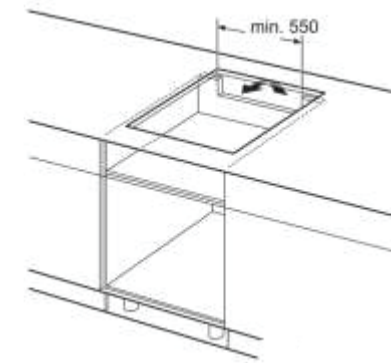
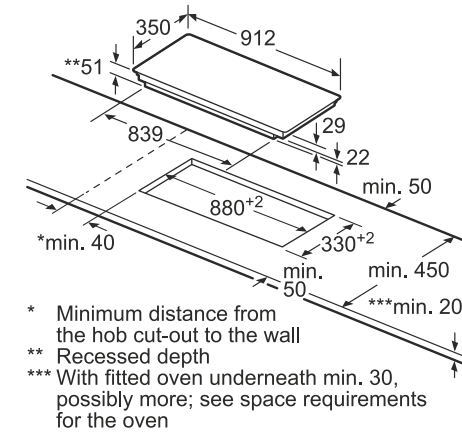

All measurements and dimensions in mm

Downdraft Hood

LD97AA670B 90cm Downdraft Hood

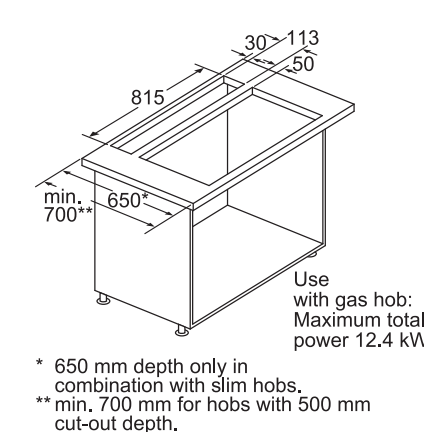

* 650 mm depth only in combination with slim hobs.
 ** min. 700 mm for hobs with 500 mm cut-out depth.

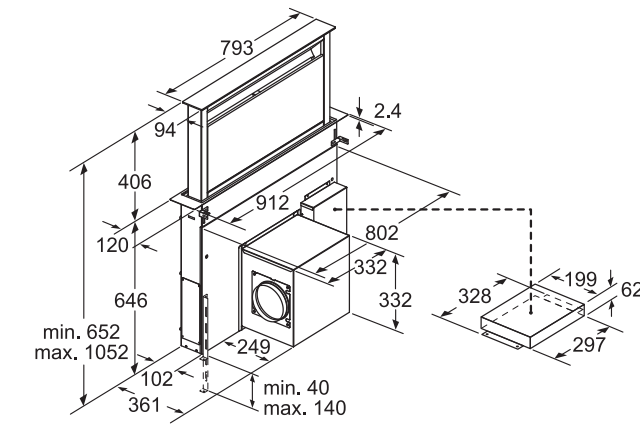

All measurements and dimensions in mm

Island Chimney Hood

LF21BA552 120cm Island Hood

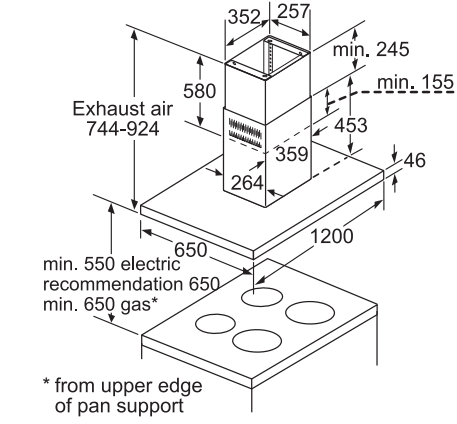

* from upper edge of pan support

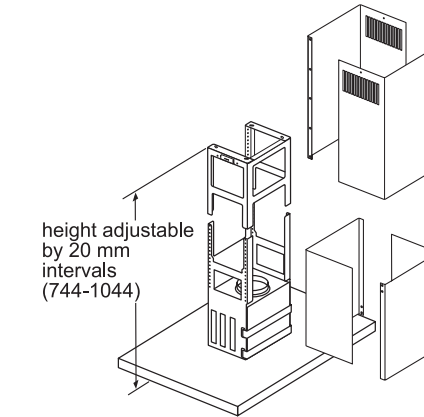

All measurements and dimensions in mm

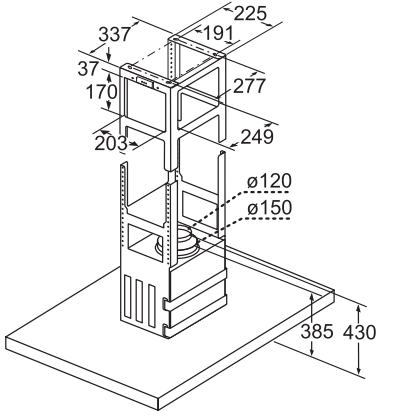

Island Chimney Hood

LF98BE542
90cm Island Hood

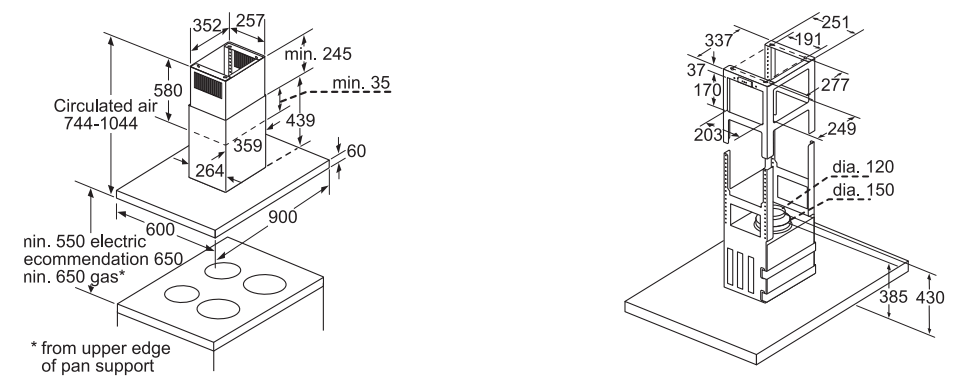
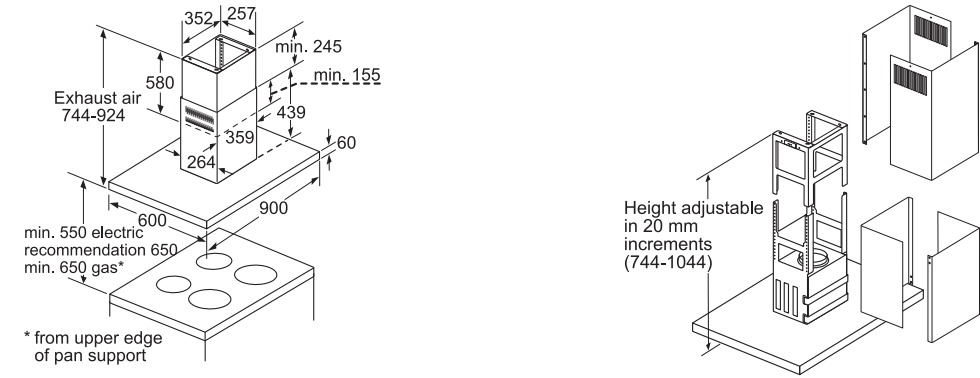

All measurements and dimensions in mm

Slimline Cooker Hood

LI97SA530B
90cm Slimline Cooker Hood

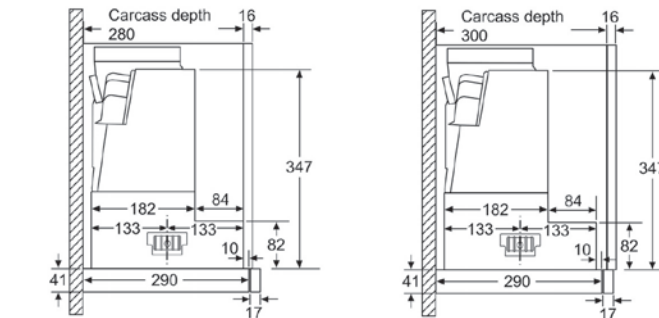
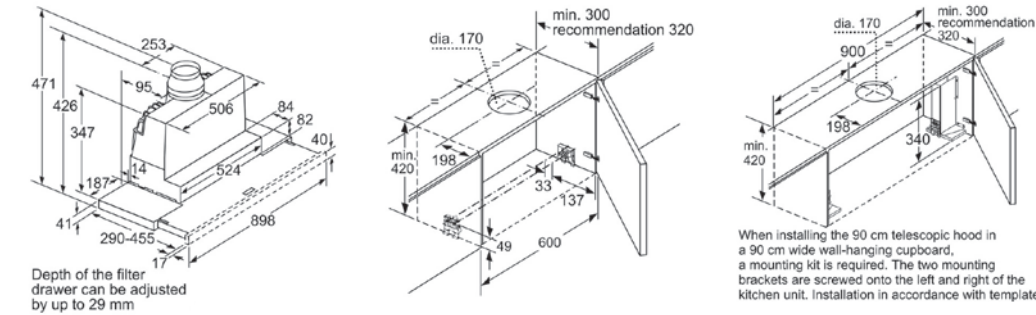

All measurements and dimensions in mm

Slimline Cooker Hood

LI64MA530
60cm Slimline Cooker Hood

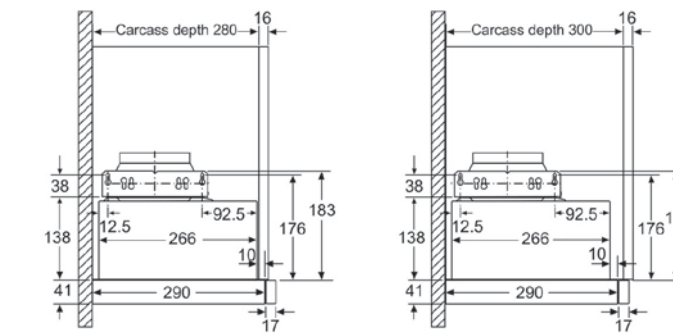
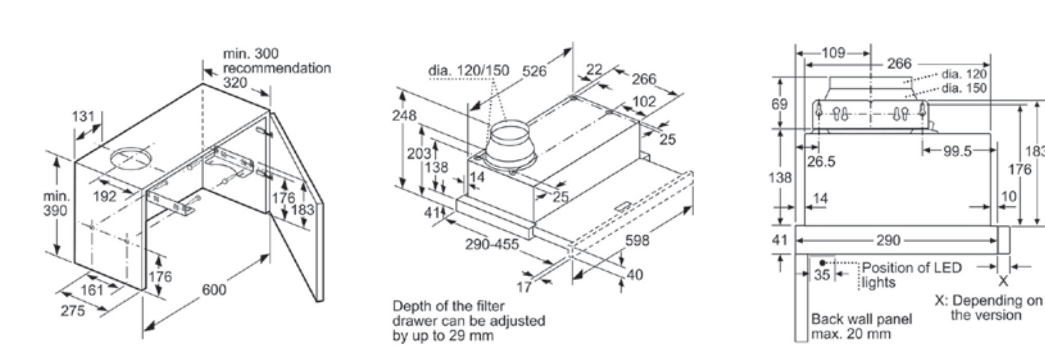

All measurements and dimensions in mm

Chimney Hood

LC91KWP60
90cm Wall Mounted Hood

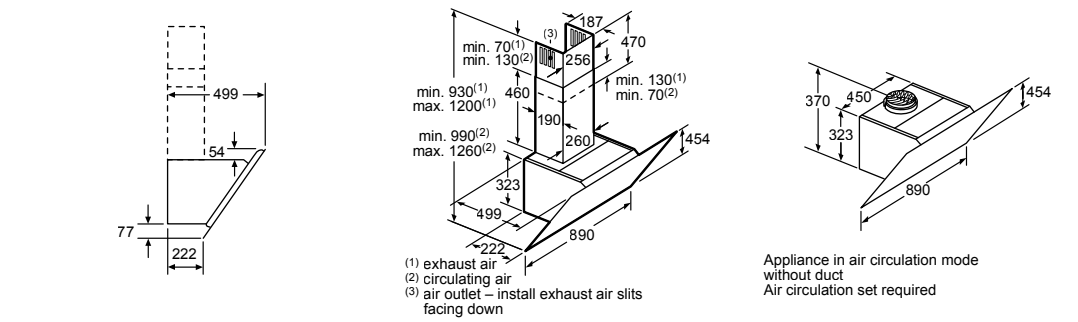
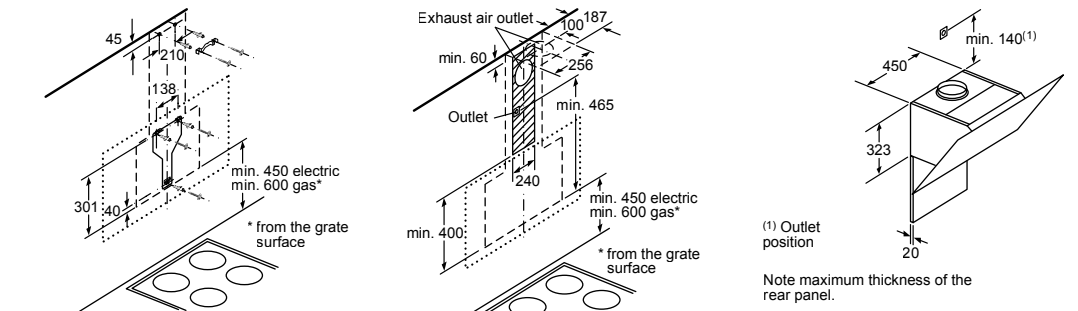

All measurements and dimensions in mm

Chimney Hood

LC91BA572 90cm Chimney Hood

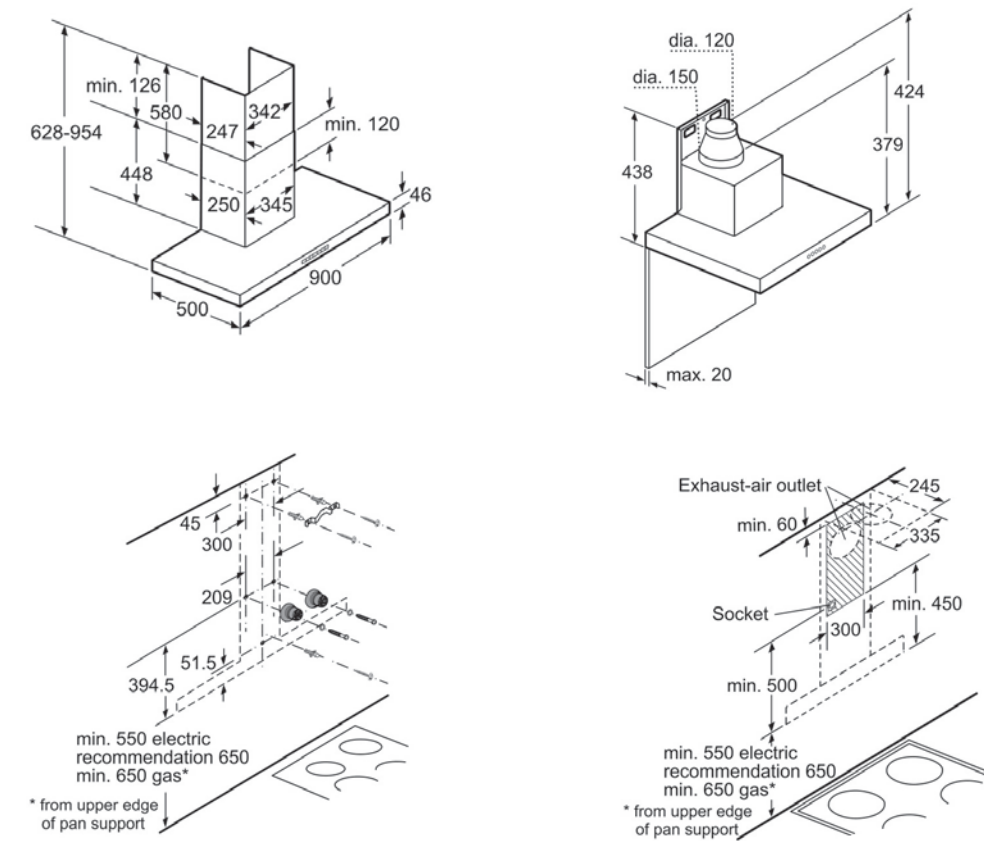

All measurements and dimensions in mm

LC91BD552I 90cm Chimney Hood

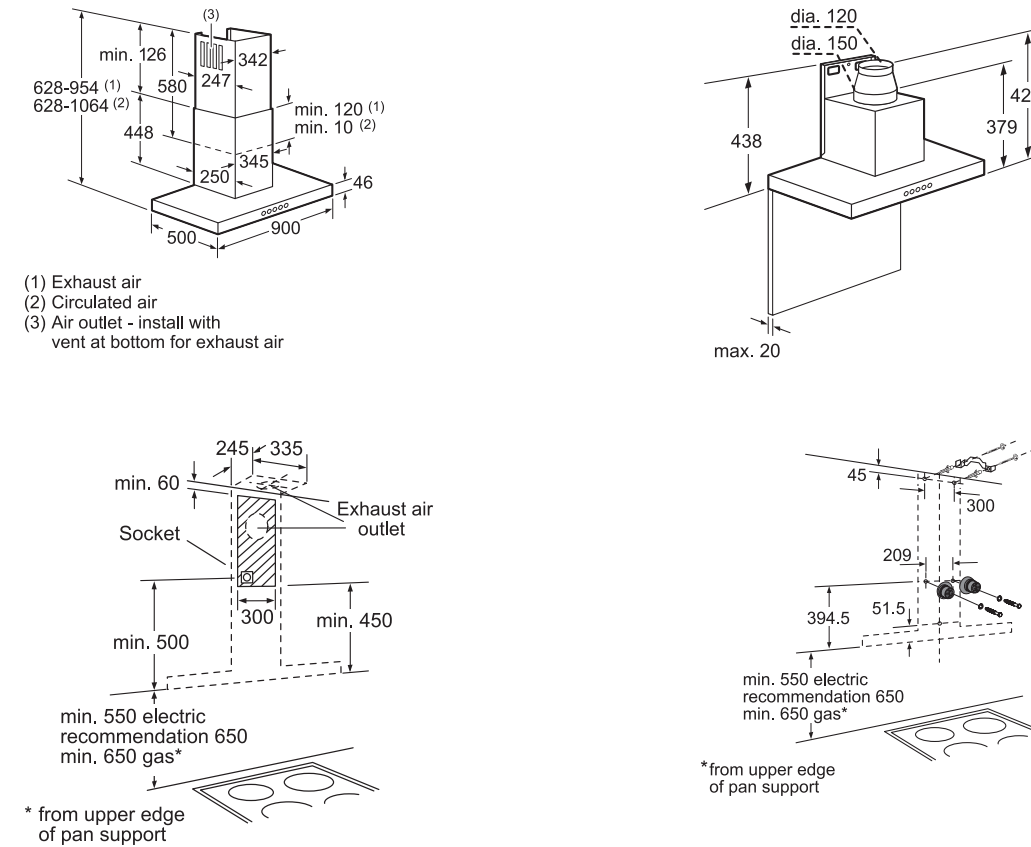

All measurements and dimensions in mm

Chimney Hood

LC98BD542I 90cm Chimney Hood

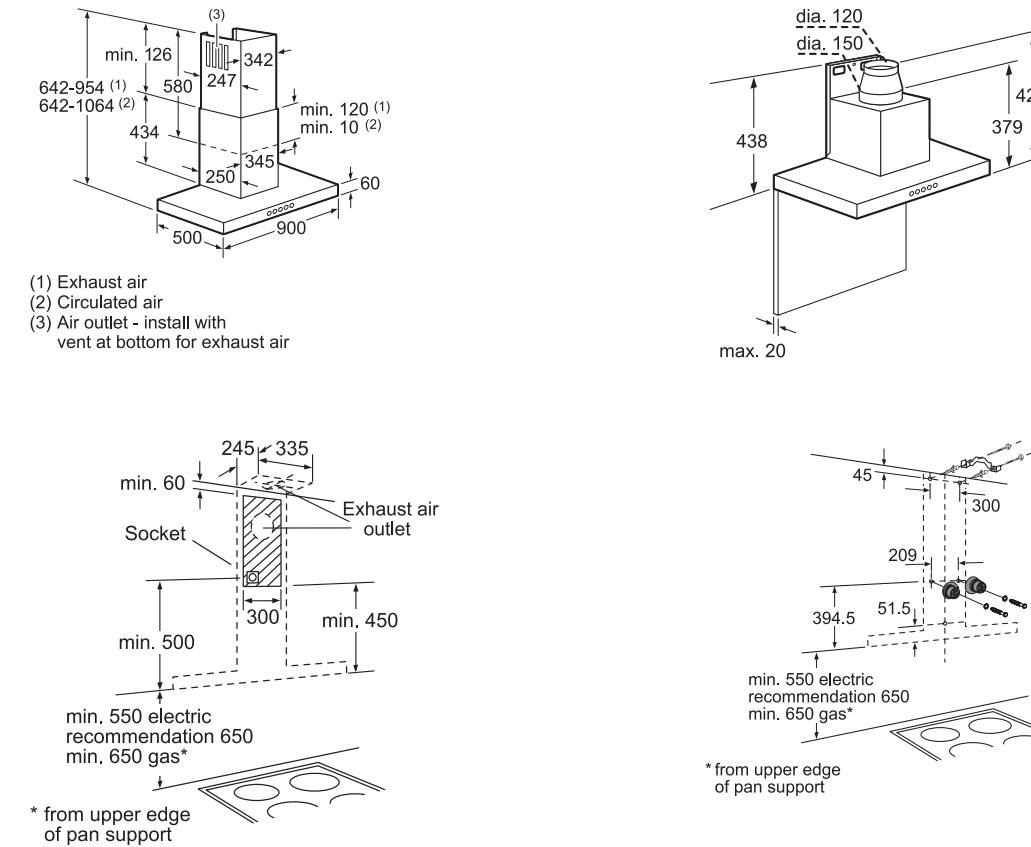

All measurements and dimensions in mm

LC91BB542 90cm Chimney Hood

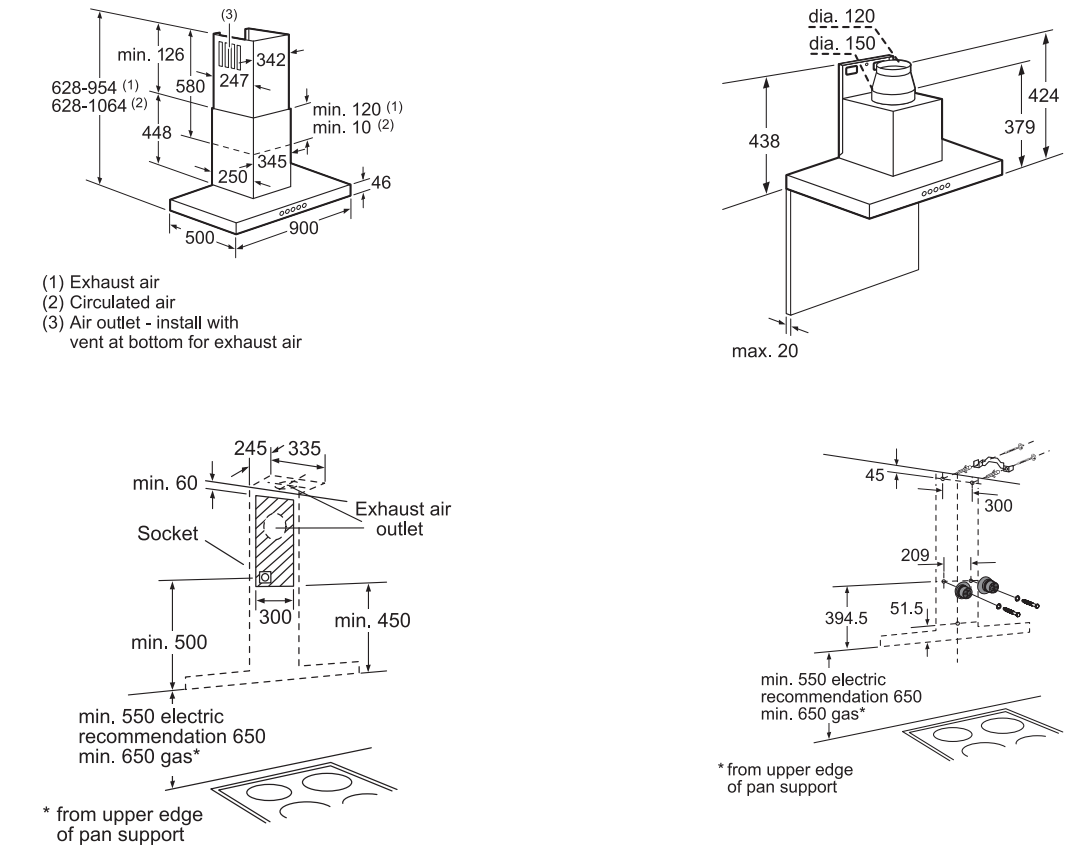

All measurements and dimensions in mm

Chimney Hood

LC28BH542
120cm Chimney Hood

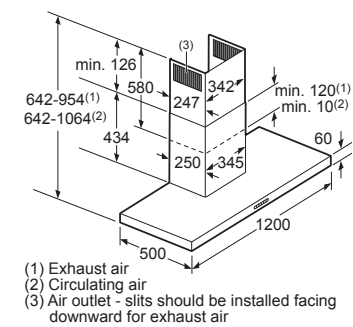

All measurements and dimensions in mm

LC68BF542
60cm Chimney Hood

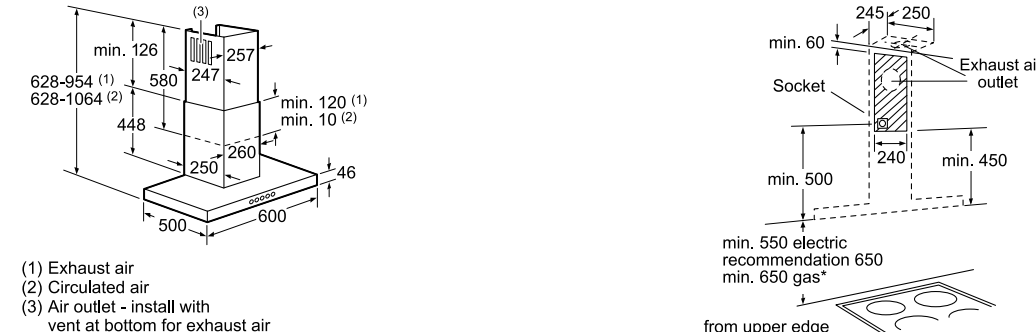

All measurements and dimensions in mm

Coffee Centre

CT636LES1
45cm Fully Automatic Coffee Maker

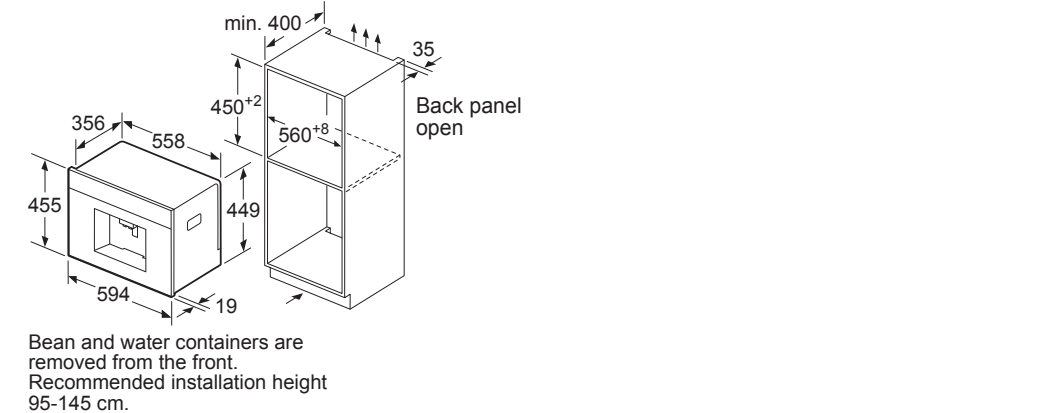
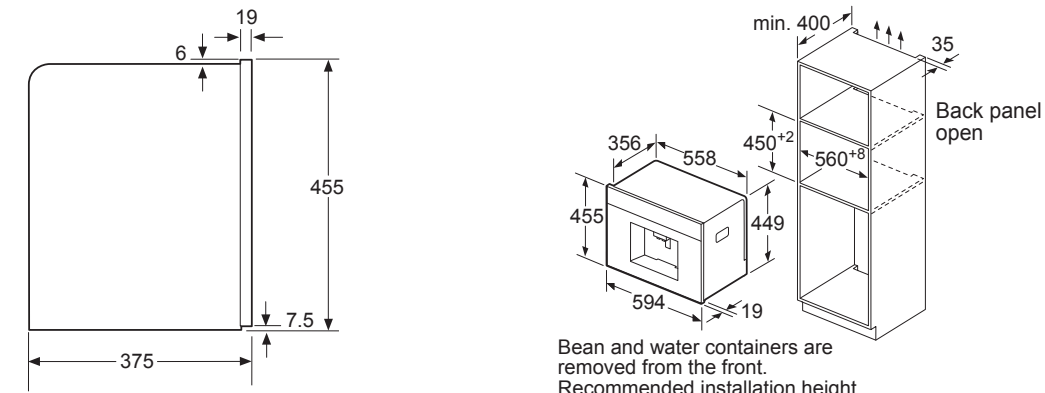

All measurements and dimensions in mm

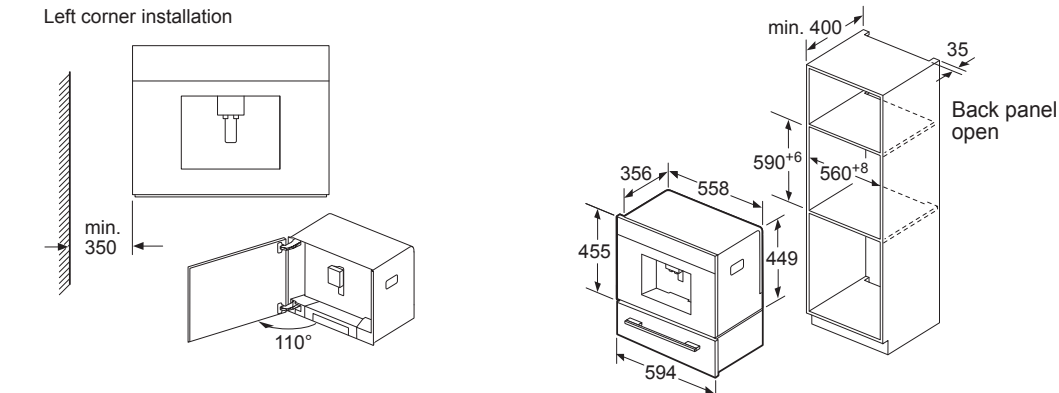

All measurements and dimensions in mm

Warmer Drawer

BI630CNS1

14cm Warmer Drawer

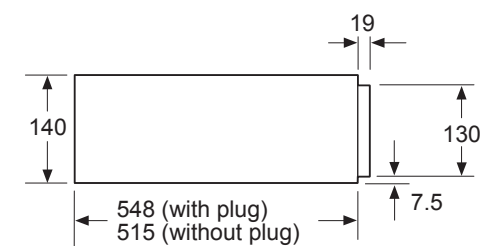

Compact ovens with an appliance height of 595 mm can be installed above a warming drawer. An intermediate floor is not required.

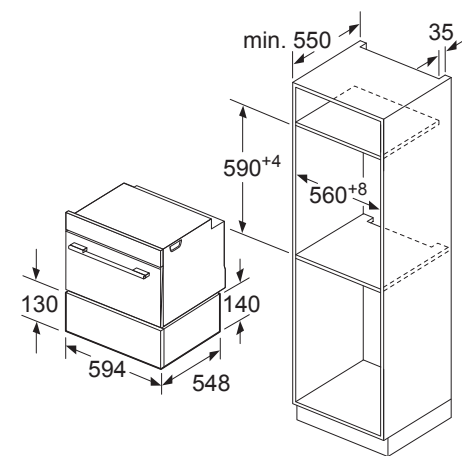

BI630DNS1

29cm Warmer Drawer

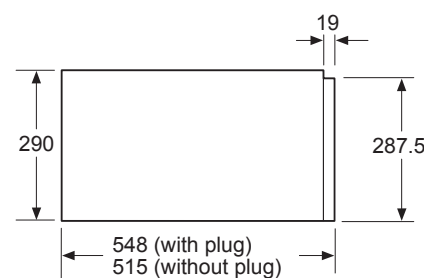

Ovens with an appliance height of 595 mm can be installed above a warming drawer. An intermediate floor is not required.

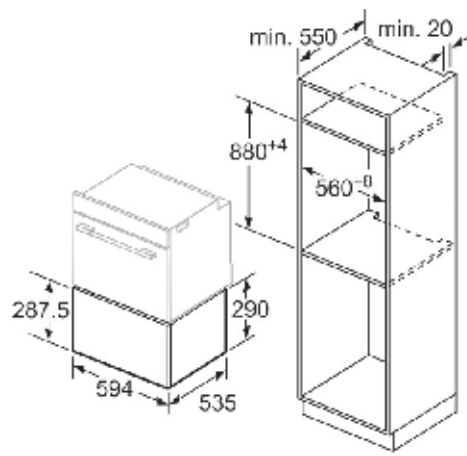

All measurements and dimensions in mm

Dishwasher

SN758X06TE

60 cm, Fully integrated, Zeolith drying, Vario Hinge, 14 place settings

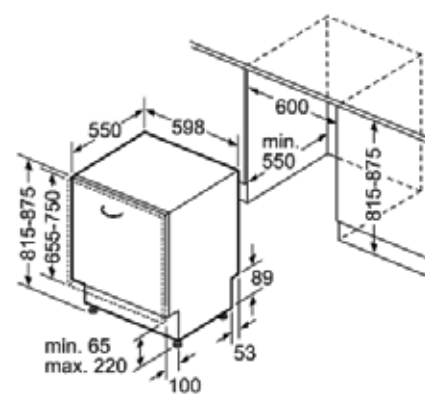

SN558S06TE

60cm, Fully Integrated Dishwasher, Zeolith® drying, 14 place settings

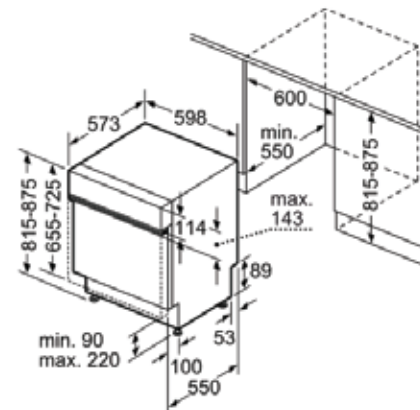

Dishwasher

SN636X00ME

60 cm, Fully-integrated, 14 place settings

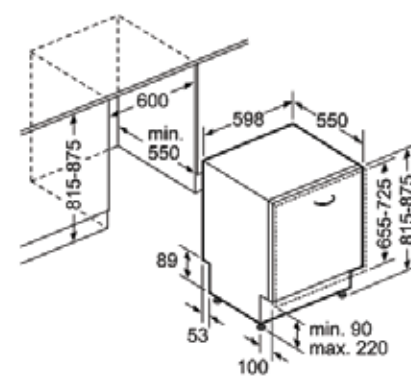

SN536S01KE

60 cm, Semi-integrated, 13 place settings

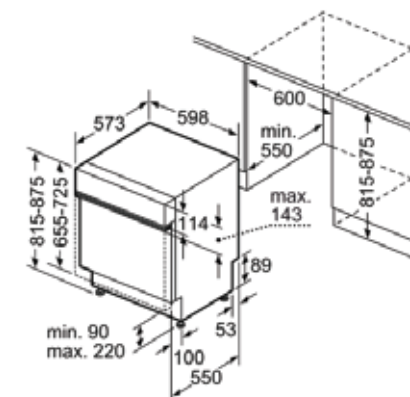

SN615X00EE

60 cm, Fully integrated, 13 place settings

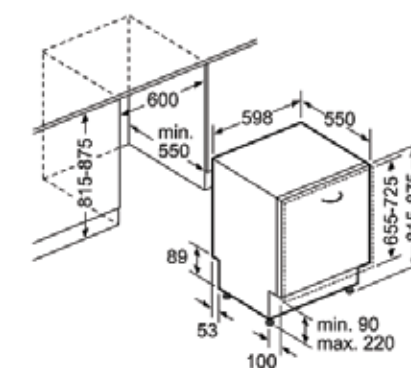

Fridge

CI30RP01

75cm | Gross capacity 547l

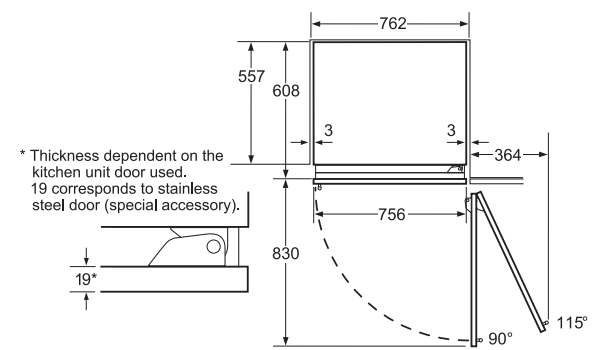
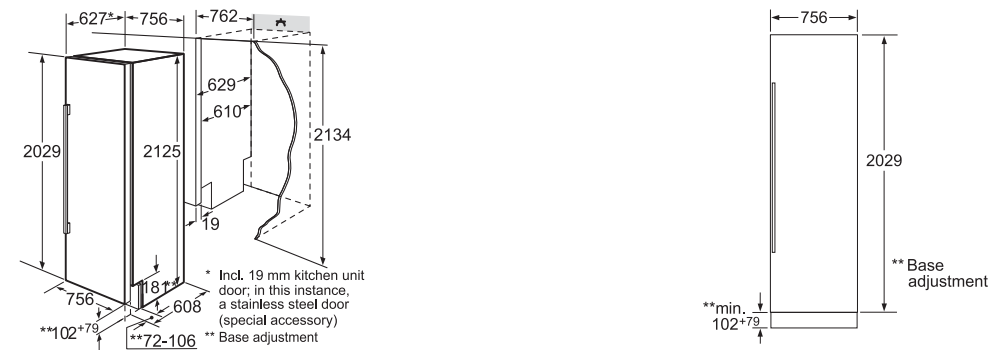

All measurements and dimensions in mm

FI24DP32

60cm | Gross capacity: 359l

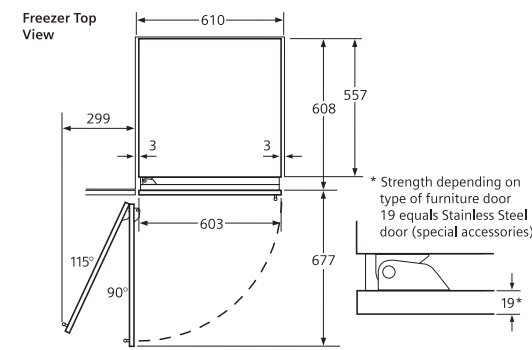
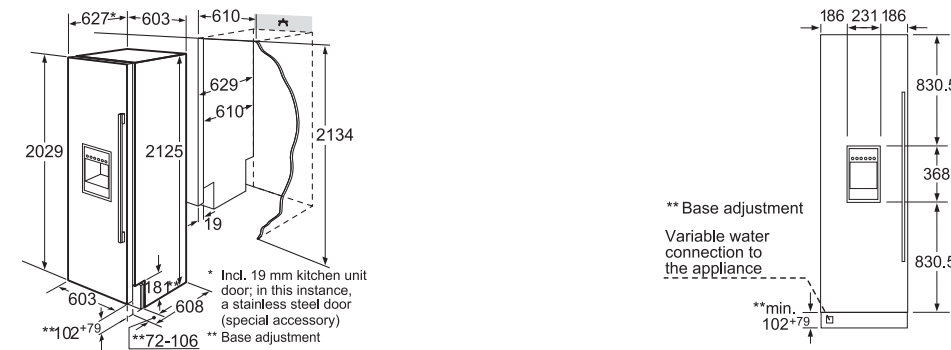

All measurements and dimensions in mm

Fridge

CI24RP01

60 cm | Gross capacity: 423l

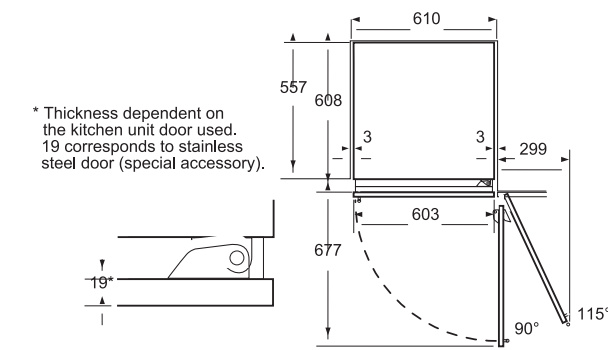
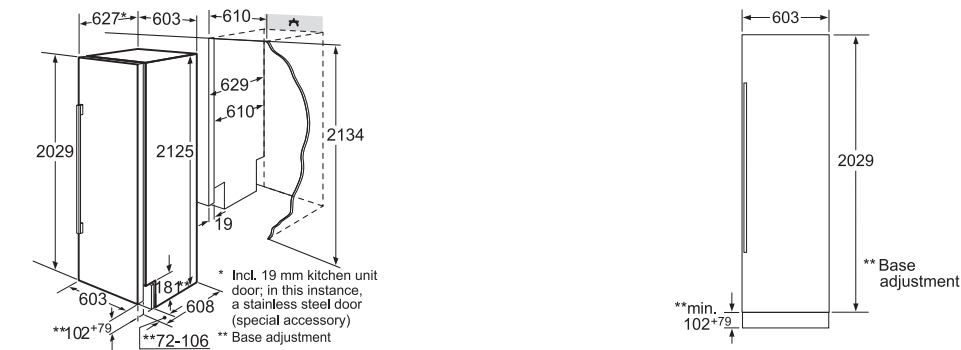

All measurements and dimensions in mm

FI24NP31

60cm | Gross capacity: 379l

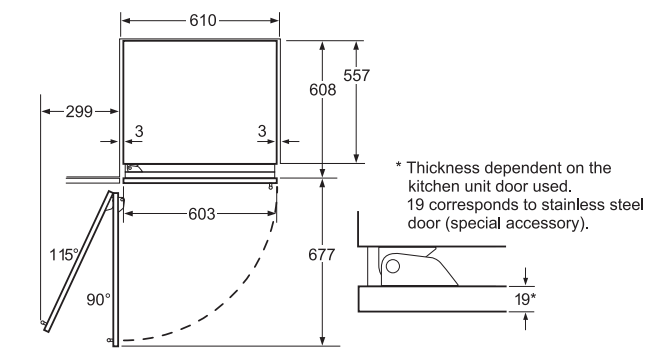
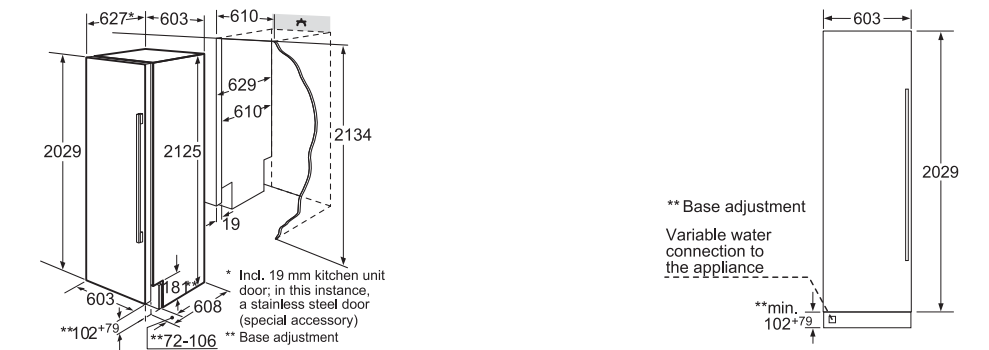

All measurements and dimensions in mm

Freezer

KI81RAF30

56cm Auto Defrost Fridge | Gross Capacity: 321l

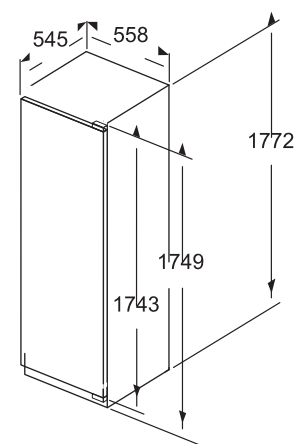
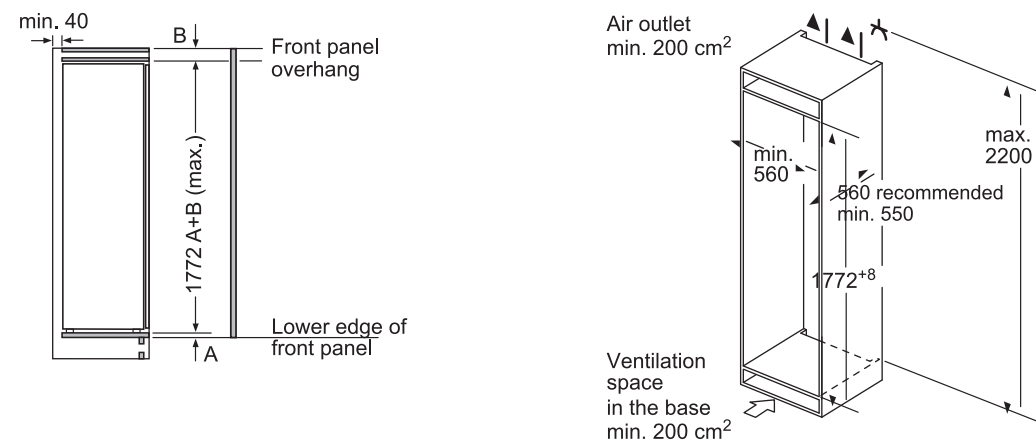

All measurements and dimensions in mm
Heating Kit on either side of the refrigerators are mandatory, please ask the Siemens Expert for More information

French Door

GI81NAE30

56 cm No Frost Freezer | Gross Capacity: 231l

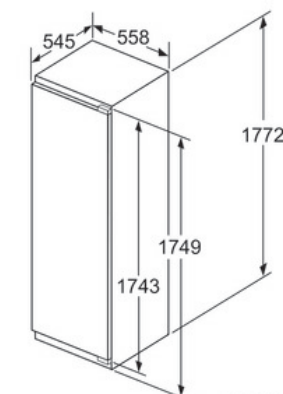
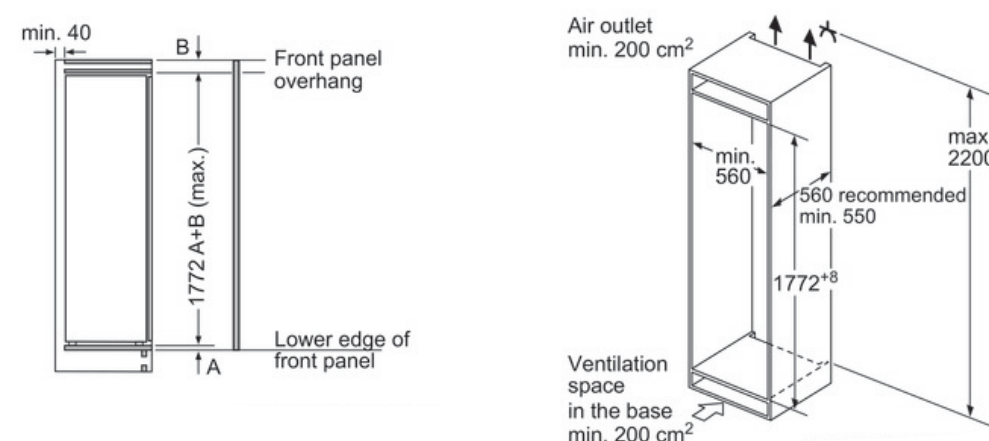

All measurements and dimensions in mm
Heating Kit on either side of the refrigerators are mandatory, please ask the Siemens Expert for More information

Bottom Freezer

CI36BP01

90cm French Door | Gross capacity 633l

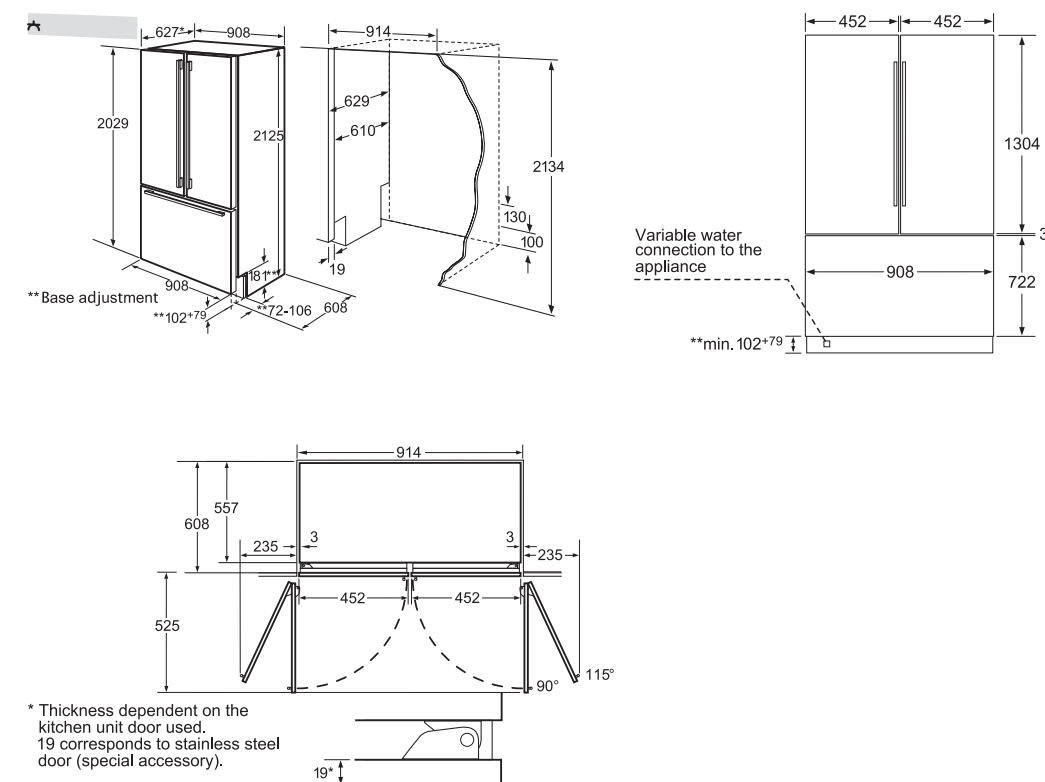

All measurements and dimensions in mm

KI34NP60

55cm Bottom Freeze | Gross capacity: 287l

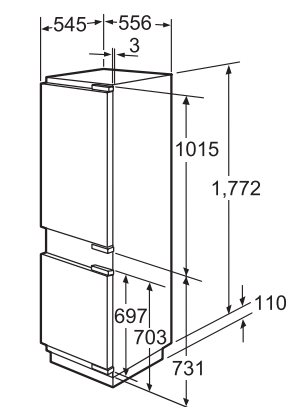
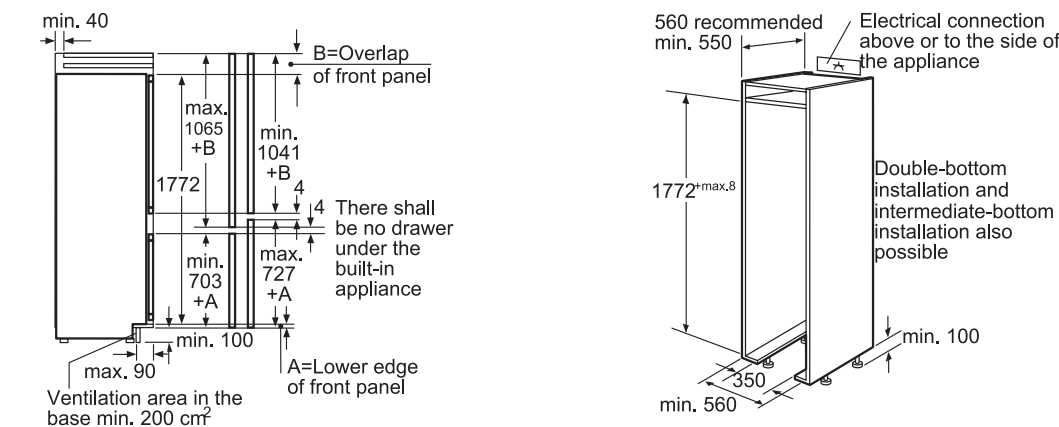

All measurements and dimensions in mm
Heating Kit on either side of the refrigerators are mandatory, please ask the Siemens Expert for More information

Fridge Freezer

KI87SAF30I

60cm | Gross capacity: 359l

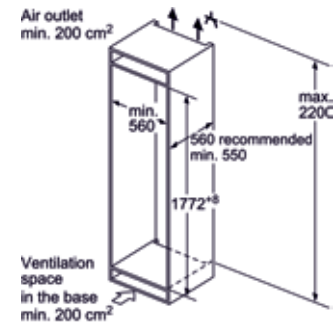
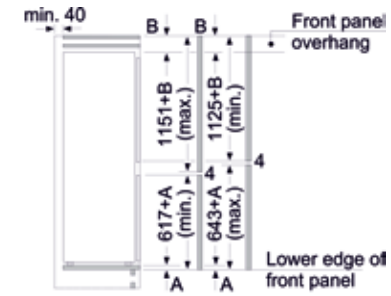

The specified unit door dimensions are valid for a door gap of 4 mm.

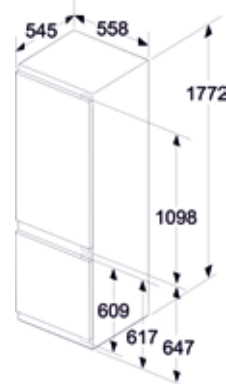

All measurements and dimensions in mm

Fridge

KU15RA50NE

60cm Auto Defrost Fridge | Gross Capacity: 139l

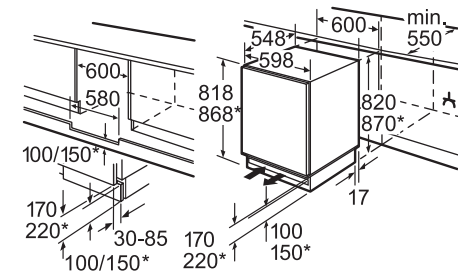

* Variable base/substructure height

Space for electrical connection next to the appliance on the left or right-hand side. Ventilation in the base.

All measurements and dimensions in mm
Heating Kit on either side of the refrigerators are mandatory, please ask the Siemens Expert for More information

Freezer

GU15DA55

60cm Fully Integrated Freeze | Gross capacity: 114l

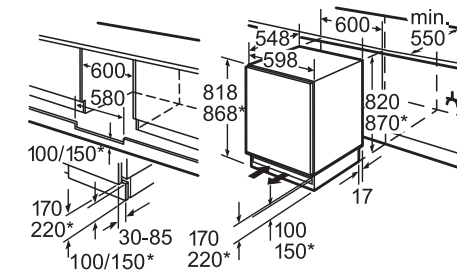

* Variable base/substructure height

Space for electrical connection next to the appliance on the left or right-hand side. Ventilation in the base.

All measurements and dimensions in mm
Heating Kit on either side of the refrigerators are mandatory, please ask the Siemens Expert for More information

Fridge Freezer

KI18LV52

56cm Auto Defrost Fridge | Gross Capacity: 137l

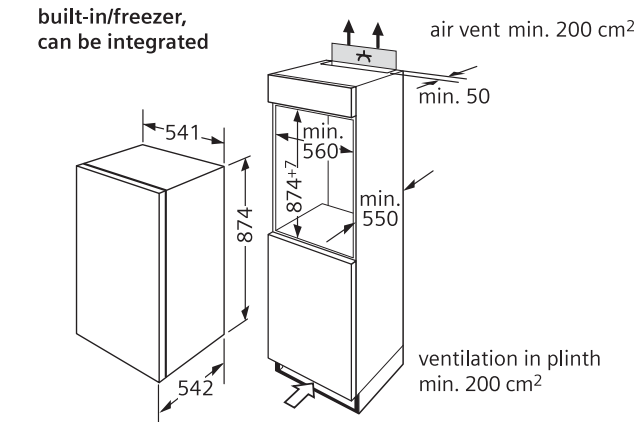

All measurements and dimensions in mm

Wine Cooler

CI24WP02

60cm | Gross capacity: 445l

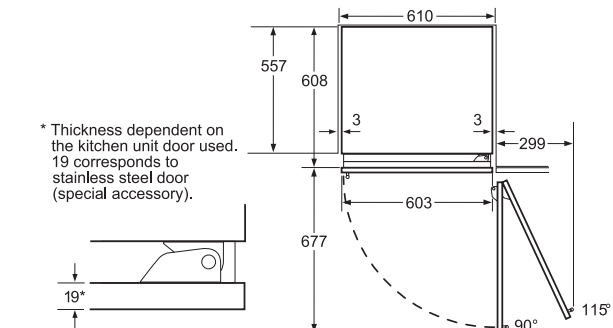

* Thickness dependent on the kitchen unit door used. 19 corresponds to stainless steel door (special accessory).

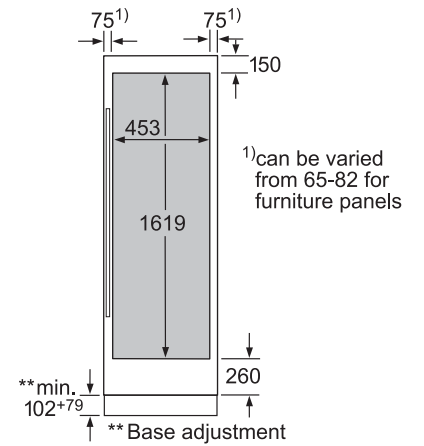

¹ can be varied from 65-82 for furniture panels

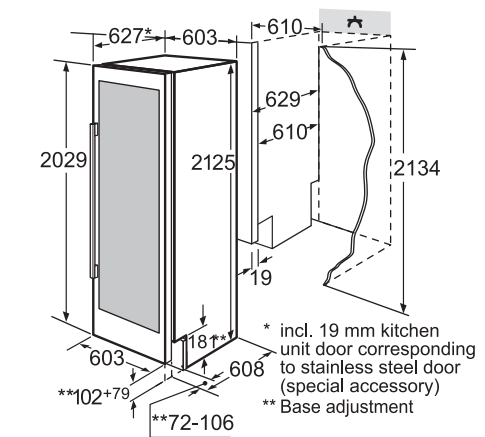

* incl. 19 mm kitchen unit door corresponding to stainless steel door (special accessory)
** Base adjustment

All measurements and dimensions in mm

Side-by-Side Refrigerator

KA92DSB30

91cm Free standing Side-by-Side Refrigerator | 636l

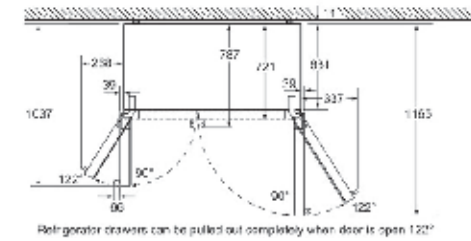
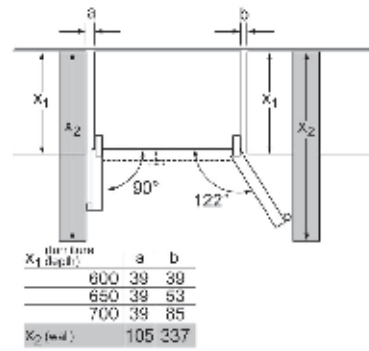
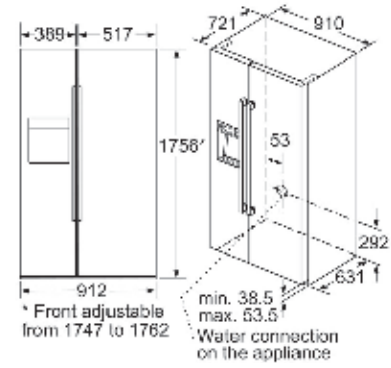

All measurements and dimensions in mm

Side-by-Side Refrigerator

KA92NLB35

91cm Free standing Side-by-Side Refrigerator | 655l

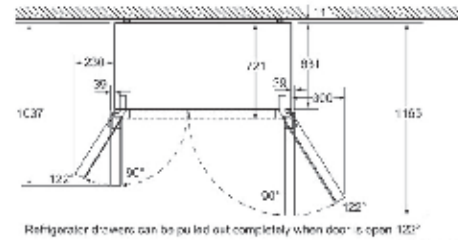
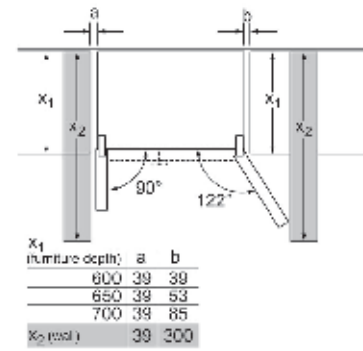
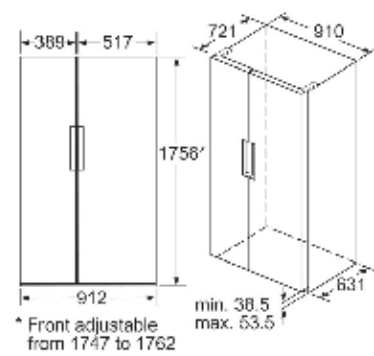

All measurements and dimensions in mm

Fridge Freezer

KA56NV40NE

91cm Free Standing Side-by-Side Refrigerator | 555l

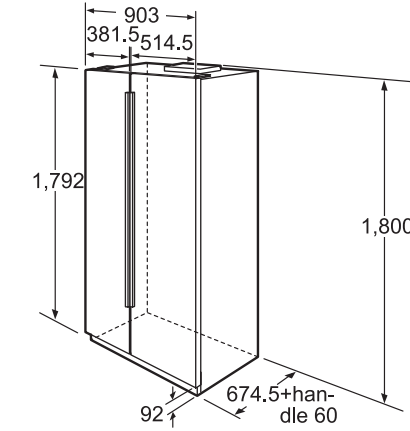

All measurements and dimensions in mm