

SIEMENS

EE...BPB..

Induction hob



EN User manual and installation instructions



Register your appliance on My Siemens
and discover exclusive services and offers.

Siemens Home Appliances

You can find additional information and explanations online.
Scan the QR code on the title page.



Table of contents

INFORMATION FOR USE

1	Safety	2
2	Basic operation of the appliance	4
3	Troubleshooting	6
4	Customer Service	7

5	Environmental protection	7
6	INSTALLATION INSTRUCTIONS	8
6.1	General information	8
6.2	Safe installation	8
7	Access additional information about the device	10

1 Safety

Observe the following safety instructions.

1.1 General information

- Read this instruction manual carefully.
- Keep the instructions, the appliance and the product information safe for future reference or for the next owner.
- Do not connect the appliance if it has been damaged in transit.

1.2 Intended use

Only a licensed professional may connect appliances without plugs. Damage caused by incorrect connection is not covered under the warranty.

The appliance can only be used safely if it is correctly installed according to the safety instructions. The installer is responsible for ensuring that the appliance works perfectly at its installation location.

Only use this appliance:

- To prepare meals and drinks.
- Under supervision. Never leave the appliance unattended when cooking for short periods.
- in private households and in enclosed spaces in a domestic environment.
- Up to an altitude of 4000 m above sea level.

Do not use the appliance:

- With an external timer or a separate remote control. This does not apply if operation with appliances included in EN 50615 is switched off.

If you wear an active implantable medical device (e.g. a pacemaker or defibrillator), check with your doctor that it complies with

Council Directive 90/385/EEC of 20th June 1990, EN 45502-2-1 and EN 45502-2-2, and that it has been chosen, implanted and programmed in accordance with VDE-AR-E 2750-10. If these conditions are satisfied, and if, in addition, non-metal cooking utensils and cookware with non-metal handles are used, it is safe to use this induction hob as intended.

1.3 Restriction on user group

This appliance may be used by children aged 8 or over and by people who have reduced physical, sensory or mental abilities or inadequate experience and/or knowledge, provided that they are supervised or have been instructed on how to use the appliance safely and have understood the resulting dangers.

Do not let children play with the appliance. Children must not perform cleaning or user maintenance unless they are at least 15 years old and are being supervised.

Keep children under the age of 8 years away from the appliance and power cable.

1.4 Safe use

WARNING – Risk of fire!

Leaving fat or oil cooking on an unattended hob can be dangerous and may lead to fires.

- ▶ Never leave hot oil or fat unattended.
- ▶ Never attempt to extinguish a fire using water; instead, switch off the appliance and then cover with a lid or a fire blanket.

The cooking surface becomes very hot.

- ▶ Never place flammable objects on the cooking surface or in its immediate vicinity.

- ▶ Never place objects on the cooking surface. The appliance will become hot.
- ▶ Do not keep combustible objects or aerosol cans in drawers directly underneath the hob. Hob covers can cause accidents, for example due to overheating, catching fire or materials shattering.

- ▶ Do not use hob covers.

After every use, switch off the hob using the main switch.

- ▶ Do not wait until the hob turns off automatically as there are no longer any pots and pans on it.

Food may catch fire.

- ▶ The cooking process must be monitored. A short process must be monitored continuously.

⚠ WARNING – Risk of burns!

The appliance and its parts that can be touched become hot during use, particularly the hob surround, if fitted.

- ▶ Caution should be exercised here in order to avoid touching heating elements.
- ▶ Young children under 8 years of age must be kept away from the appliance.

Hob guards may cause accidents.

- ▶ Never use hob guards.

The appliance becomes hot during operation.

- ▶ Allow the appliance to cool down before cleaning.

Metal objects on the hob quickly become very hot.

- ▶ Never place metal objects (such as knives, forks, spoons and lids) on the hob.

⚠ WARNING – Risk of electric shock!

Improper repairs are dangerous.

- ▶ Repairs to the appliance should only be carried out by trained specialist staff.
- ▶ Only use genuine spare parts when repairing the appliance.
- ▶ If the power cord or the appliance power cable of this appliance is damaged, it must be replaced with a special power cord or special appliance power cable, which is available from the manufacturer or its Customer Service.

- ▶ If the power cord of this appliance is damaged, it must be replaced by trained specialist staff.

If the appliance or the power cord is damaged, this is dangerous.

- ▶ Never operate a damaged appliance.

- ▶ If the surface is cracked, you must switch off the appliance in order to prevent a possible electrical shock. To do this, switch off the appliance via the fuse in the fuse box rather than at the main switch.

- ▶ Never pull on the power cord to unplug the appliance. Always unplug the appliance at the mains.

- ▶ If the appliance or the power cable is damaged, immediately switch off the fuse in the fuse box.

- ▶ Call customer service. → *Page 7*

An ingress of moisture can cause an electric shock.

- ▶ Do not use steam- or high-pressure cleaners to clean the appliance.

The insulation on cables of electrical appliances may melt if it touches hot parts of the appliance.

- ▶ Never bring electrical appliance cables into contact with hot parts of the appliance.

If metallic objects come into contact with the fan that is located on the underside of the hob, this may cause an electric shock.

- ▶ Do not store long, pointed metallic objects in the drawers below the hob.

⚠ WARNING – Risk of injury!

Saucepans may suddenly jump due to liquid between the saucepan base and the hotplate.

- ▶ Always keep hotplates and saucepan bases dry.

- ▶ Never use icy-cold cookware that has been in the freezer.

When cooking in a bain marie, the hob and cooking container could shatter due to overheating.

- ▶ The cooking container in the bain marie must not directly touch the bottom of the water-filled pot.
- ▶ Only use heat-resistant cookware.

An appliance with a cracked or broken surface can cause cuts.

- ▶ Do not use the appliance if it has a cracked or broken surface.

⚠ WARNING – Risk of suffocation!

Children may put packaging material over their heads or wrap themselves up in it and suffocate.

- ▶ Keep packaging material away from children.
- ▶ Do not let children play with packaging material.

Children may breathe in or swallow small parts, causing them to suffocate.

- ▶ Keep small parts away from children.
- ▶ Do not let children play with small parts.

2 Basic operation of the appliance

2.1 Control panel

Individual details, such as colour and shape, may differ from the figure.

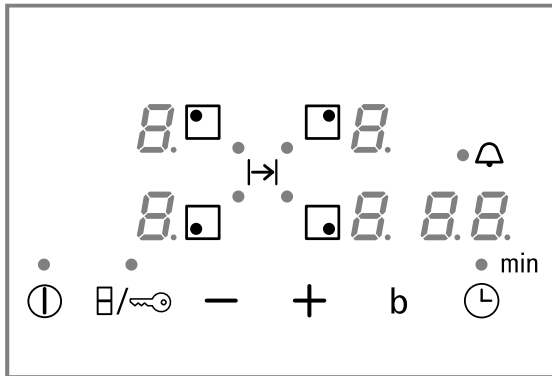

Touch fields

Sensor	Function
ⓘ	Main switch
□	Selecting the cooking zone
⊞	combiZone
-/+	Selecting settings
b	powerBoost
⌚	Time-setting options
🔒	Childproof lock

Indicators/symbols

Display	Function
1-9	Power levels
H/h	Residual heat
b	powerBoost
⌚	Time-setting options

2.2 Basic operation

Switching the hob on and off

- ▶ Switch the hob on and off using the main switch ⓘ. If all of the cooking zones are switched off for longer than 20 seconds, the hob is automatically switched off.

reStart

- ▶ If you switch the appliance on within four seconds of switching it off, the hob operates with the settings that were previously set.

Selecting the cooking zone and power level

1. Touch □ to select the cooking zone.
2. Within the next 10 seconds, select the required power level:
 - ▶ Touch + to call up power level 9.

- ▶ Touch - to call up power level 4.
3. Touch + or - until the required power level appears. To switch off the cooking zone, set 0.
- ✓ The minimum power level is 1 and the maximum power level is 9.
 - ✓ Each power level has an intermediate level. This is marked with a dot.
 - ✓ When the cooking zone switches off, the residual heat indicator lights up.

Switching off the cooking zone quickly

- ▶ Press and hold the cooking zone for longer than three seconds.
- ✓ The cooking zone is switched off.

Suitable cookware

The quality of the cookware affects the speed and the result of the cooking process.

Cookware that is suitable for induction cooking must have a ferromagnetic base, i.e. it is attracted to magnets. Furthermore, the base must match the size of the cooking zone. If an item of cookware is not detected on a cooking zone, place this cookware on the next smallest cooking zone.

2.3 Distribution of the cooking zones

The specified power has been measured with the standard pots, which are described in IEC/EN 60335-2-6. The power may vary depending on the size of the cookware or cookware material.

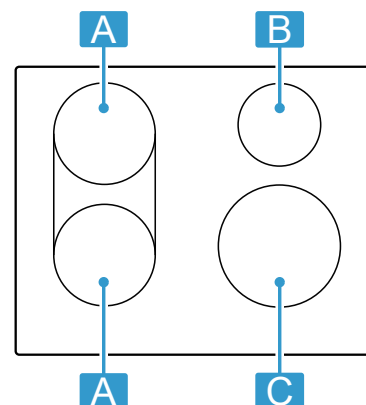

Area	Highest power level	
A 18 cm diameter Ⓢ	Power level 9	1800 W
Ⓢ	powerBoost	3100 W
A Diameter 18+18 cm Ⓢ	Power level 9	3600 W
B 14.5 cm diameter	Power level 9	1400 W
	powerBoost	2200 W
C 21 cm diameter	Power level 9	2200 W
	powerBoost	3700 W

2.4 Cooking zones

Area	Cooking zone type
○	Single-circuit cooking zone
⊗	Combi cooking zone → <i>Page 5</i>

2.5 combiZone

It allows two cooking zones to be combined, with the same power level being switched on in both. For cooking with an oblong pan or for moving a single pan from one zone to another.

Activating combiZone

1. Position the cookware so that it covers the zone or zones that are to be switched on. Ensure that the size of the cookware is suitable for the selected zone.

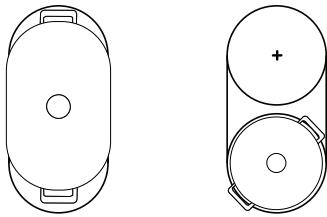

2. Select one of the cooking zones and set the power level.
 3. Touch **⊗**.
- ✓ • lights up and the power level on the displays for both cooking zones lights up.

Deactivating combiZone

- ▶ Touch **⊗**.
- ✓ The two cooking zones now operate independently of one another.

2.6 Main functions

Time-setting options

Your hob has various functions for setting the cooking time:

- **Switch-off timer**
Allows you to programme a cooking time for a cooking zone and its automatic switch-off once the set time has elapsed.
- **Timer**
You can use this function to switch on a timer. This function operates independently of the cooking zones and other settings. It does not automatically switch off the cooking zones.

powerBoost

This function allows larger volumes of water to be heated more quickly than with the power level **9**.

Childproof lock

The hob is equipped with a childproof lock. This prevents children from switching on the hob.

To switch the function on, the hob must be switched off. Touch **↔** for four seconds to switch on or off.

Basic settings

You can configure the basic settings for your appliance to meet your needs.

For example, to configure the audible signals of the appliance or to carry out the Cookware test.

Additional information about the appliance functions



You can find additional information and explanations online.

Scan the QR code on the title page or visit the sections on your appliance and Customer Service at siemens-home.bsh-group.com.



2.7 Cooking recommendations

The table shows which power level (**1-9**) is suitable for which food. The cooking time (⌚ min) may vary depending on the type, weight, thickness and quality of the food.

	1-9	⌚ min
Melting		
Chocolate coating	1 - 1.	-
Heating and keeping warm		
Stew, e.g. lentil stew	1. - 2	-
Defrosting and heating		
Spinach, frozen	3 - 4	15 - 25
Poaching, simmering		
White sauces, e.g. Béchamel sauce	1 - 2	3 - 6
Boiling, steaming, braising		
Rice pudding ¹	2 - 3	30 - 40
Pasta, noodles ²	6 - 7	6 - 10
Vegetables	2. - 3.	10 - 20
Braising		
Pot roast	4 - 5	60 - 100
Roasting/frying with a small amount of fat ²		
Steak, 3 cm thick	7 - 8	8 - 12
Hamburgers (2 cm thick)	6 - 7	10 - 20
Frozen dishes, e.g. stir-fries	6 - 7	6 - 10
Pancakes, cooked one after the other	6. - 7.	-
Fried eggs	5 - 6	3 - 6
Frying (150 to 200 g per batch in 1 to 2 l oil, deep-fried in batches) ²		
Frozen products, e.g. chips, chicken nuggets	8 - 9	-

¹ Preheat to power level 8 - 8.

² Without lid

		 min
Vegetables, mushrooms, breaded, beer-battered or tempura	6 - 7	-

2.8 Cleaning the hob

Clean the hob after every use to prevent cooking residues from getting burnt on.

Requirement: The hob must be cold. Do not allow the hob to cool down if it has sugar stains, rice starch, plastic or aluminium foil on it.

1. Remove heavy soiling using a glass scraper.

2. Clean the hob with a cleaning agent for glass ceramic. Follow the cleaning instructions on the packaging of the cleaning product.
3. Wipe it with a damp cloth and dry it with a cloth.

Tips

- You can achieve good cleaning results using a special sponge for glass ceramic.
- If you keep the base of the cookware clean, the hob surface remains in a good condition.
- Rough cookware bases, salt, sugar and sand may cause scratches and discolourations. Lift the cookware when moving it.

3 Troubleshooting

You can rectify minor faults on your appliance yourself. Read the troubleshooting information before contacting after-sales service. This will avoid unnecessary costs.

WARNING – Risk of injury!

Improper repairs are dangerous.

- ▶ Repairs to the appliance should only be carried out by trained specialist staff.
- ▶ If the appliance is defective, call Customer Service.
→ "Customer Service", Page 7

3.1 Warnings

Notes

- If E appears in the displays, press and hold the sensor for the respective cooking zone and read the fault code.
- If the fault code is not listed in the following table, disconnect the hob from the power supply and wait 30 seconds before reconnecting it. If this display ap-

pears again, contact Customer Service and specify the exact fault code.

- If an error occurs, the appliance does not switch to low power mode.
- In order to protect the appliance's electronic parts from overheating or surge currents, the hob may temporarily reduce the power level.

3.2 Information on the display panel

Fault	Cause and troubleshooting
No displays light up.	The power supply has been disconnected. ▶ Use other electrical appliances to check whether there has been a power failure. The appliance has not been connected as shown in the circuit diagram. ▶ Connect the appliance in accordance with the circuit diagram. Electronics fault ▶ If you are unable to rectify the fault, inform the technical after-sales service.
The displays flash.	The control panel is wet or an object is covering it. ▶ Dry the control panel or remove the object.
F2, F 4, E 7015, E 8207, E 8208	The electronics have overheated and one or all of the cooking zones have been switched off. ▶ Wait until the electronics have cooled down sufficiently. Then touch any button on the control panel.
F5 + power level and audible signal	There is hot cookware in the vicinity of the control panel. This may cause the electronics to overheat. ▶ Remove the cookware. The fault display goes out shortly afterwards. You can continue to cook.
F5 and signal tone	There is hot cookware in the vicinity of the control panel. The cooking zone has been switched off to protect the electronics. ▶ Remove the cookware. Wait a few seconds. Touch any button. When the fault display goes out, you can continue cooking.

Fault	Cause and troubleshooting
F1/F6	The cooking zone has overheated and has been switched off to protect the work surface. ▶ Wait until the electronics have cooled down sufficiently before switching the cooking zone back on.
FB	The cooking zone has been operating continuously for an extended period. ▶ Individual safety switch-off is switched on. Touch any button to switch off the display so that you can set the cooking zone.
E 9000/E9010	The operating voltage is incorrect and outside of the normal operating range. ▶ Contact your energy supplier.
U400/E9011	The hob is not connected correctly. ▶ Disconnect the hob from the mains. Connect the hob in accordance with the circuit diagram.
d E	Demo mode is activated. ▶ Disconnect the hob from the mains. Wait for 30 seconds and connect the hob. Touch any sensor in the next three minutes. Demo mode is deactivated.
• appears beside 	Childproof lock is activated. ▶ Childproof lock deactivate

3.3 Normal noises from your appliance

An induction hob may sometimes cause noises or vibrations, such as buzzing, crackling, hissing noises, fan noises or rhythmic noises.

4 Customer Service

Function-relevant genuine spare parts according to the corresponding Ecodesign Directive can be obtained from Customer Service for a period of at least 10 years from the date on which your appliance was placed on the market within the European Economic Area. Furthermore, our Customer Service will continue to provide you with other function-relevant and storable genuine spare parts for up to 15 years from the date on which your appliance was placed on the market. For more information, please contact our Customer Service team.

Note: Under the terms of the manufacturer's warranty the use of Customer Service is free of charge.

Detailed information about the warranty period and the warranty conditions in your country is available via the QR code on the enclosed document on service contacts and warranty conditions, from our customer service or on our website.

You can find the contact details for our customer service via the QR code on the enclosed document on service contacts and warranty conditions or on our website.

You can find the information required as per Regulations (EU) 66/2014 and (EU) 2023/826 online at siemens-home.bsh-group.com on the product and service pages for your appliance, in the area of user manuals and additional documents.

4.1 Product number (E-Nr.) and production number (FD)

If you contact Customer Service, you will require the product number (E-Nr.) and the production number (FD), which you can find on the appliance's rating plate.

The rating plate can be found:

- on the appliance certificate.
- on the lower section of the hob.

The product number (E no.) can also be found on the glass ceramic. You can also display the customer service index (KI) and the production number (FD) in the basic settings.

Make a note of your appliance's details and the Customer Service telephone number to find them again quickly.

5 Environmental protection

5.1 Disposing of packaging

The packaging materials are environmentally compatible and can be recycled.

- ▶ Sort the individual components by type and dispose of them separately.

5.2 Disposing of old appliance

Valuable raw materials can be reused by recycling.

1. Unplug the appliance from the mains.

2. Cut through the power cord.
3. Dispose of the appliance in an environmentally friendly manner.
Information about current disposal methods are available from your specialist dealer or local authority.



This appliance is labelled in accordance with European Directive 2012/19/EU concerning used electrical and electronic appliances (waste electrical and electronic equipment - WEEE). The guideline determines the framework for the return and recycling of used appliances as applicable throughout the EU.

6 Installation instructions

Observe this information when installing the appliance.

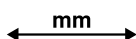

6.1 General information

- Read this instruction manual carefully.
- Only a licensed expert may connect the appliance.
- Improper installation, opening of the appliance, connection or assembly may lead to a loss of validity of the product warranty.
- Switch off the power supply before carrying out any work.
- After installation, ensure that the user does not have access to the electrical components.
- Never use this appliance in boats or in vehicles.

6.2 Safe installation

Follow these safety instructions when installing the appliance.

The appliance can only be used safely if it is correctly installed in accordance with the installation instructions. The installer is responsible for ensuring that the appliance works perfectly at its installation location.

WARNING – Danger: Magnetism!

The appliance contains permanent magnets. They may affect electronic implants, e.g. pacemakers or insulin pumps.

- ▶ Persons with electronic implants must stand at least 10 cm away from the appliance.

WARNING – Risk of injury!

Parts that are accessible during installation may have sharp edges and may lead to cutting injuries.

- ▶ Wear protective gloves.

Chemicals may be dangerous. When handling chemicals, you must observe the recommendations of the chemical producers.

- ▶ Wear personal protective equipment.

6.3 Instructions for the electrical connection

In order to safely connect the appliance to the electrical system, observe the following instructions.

- Only an authorised expert or a specially trained service technician may connect the appliance. The person must be approved in accordance with the local regulations of the country and the electricity supply company.
- Connect the appliance to a fixed installation and set up appropriate isolating switches in accordance with the installation regulations.
- The manufacturer shall assume no liability for malfunctions or damage resulting from incorrect electrical wiring.

Connection type

- The appliance corresponds to protection class 1. You should therefore only use the appliance with a protective earth connection.

6.4 Information on fitted units

- You can only install the induction hob above drawers or ovens with fan ventilation. Do not install refrigerators, dishwashers, non-ventilated ovens or washing machines below the hob.
- Ensure that the fitted unit is heat-resistant up to at least 90 °C.

Worktop

Follow the worktop manufacturer's recommendations.

- Level, horizontal, stable.
- The worktop into which you are fitting the appliance must be able to withstand loads of approx. 60 kg.
- For thin worktops, use heat-resistant and moisture-resistant reinforcement material.
- Only check the evenness of the hob after it has been installed.

Extractor hood

- The clearance between the extractor hood and the hob must correspond at least to the clearance specified in the installation instructions for the extractor hood.

6.5 Preparing the fitted units

1. Mark the unit cut-out in accordance with the installation diagram.
 - ▶ Ensure that the angle of the cut surface to the worktop is 90°.

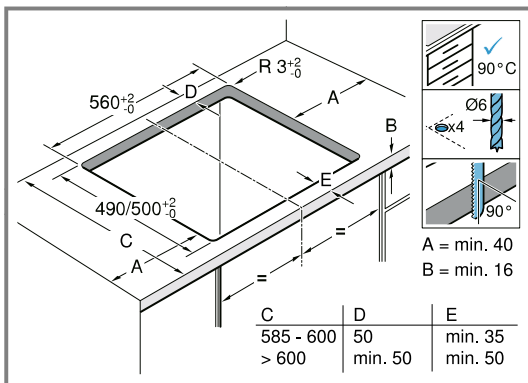

2. After making the cut-outs, remove any shavings.
3. Seal the cut surfaces with heat-resistant material.

Ventilation

To guarantee that the appliance works correctly, the hob must be sufficiently ventilated. The ventilation in the lower section of the appliance requires a sufficient supply of fresh air. Therefore, if required, adjust the units for this purpose.

1. Maintain a minimum clearance between the rear of the unit and the kitchen wall.

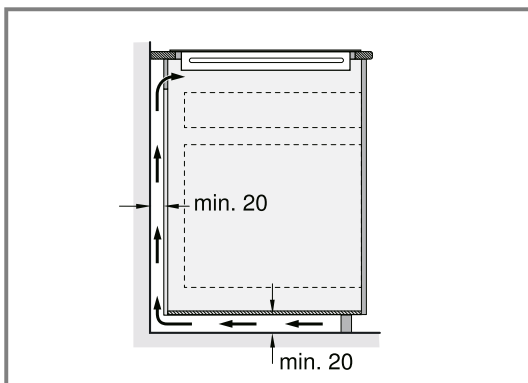

2. Ensure that an opening at the top of the rear of the unit is unobstructed.

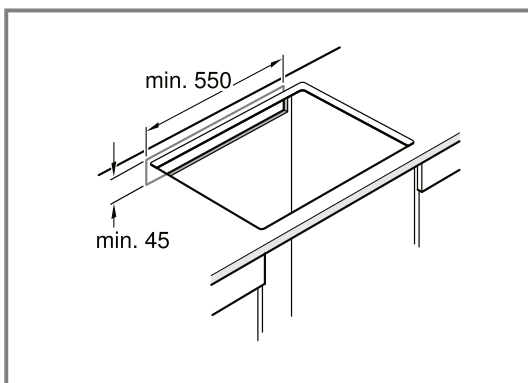

3. If the clearance from the back wall of the unit is less than 20 mm, create an opening on the underside.

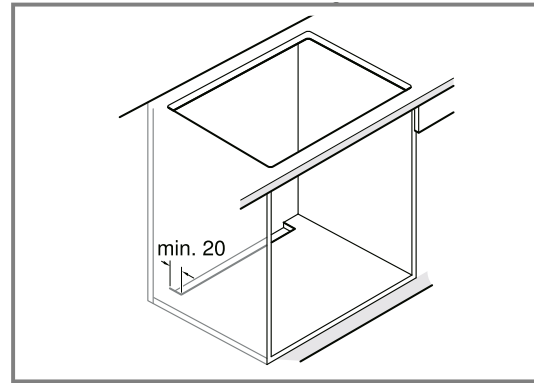

4. Do not hermetically seal the lower base.

Note: If the appliance is installed in an island unit or in another location that is not described here, guarantee that the hob is ventilated appropriately.

Installation above a drawer

- In order to guarantee good ventilation, the clearance between the surface of the worktop and the upper area of the drawer must be 65 mm.

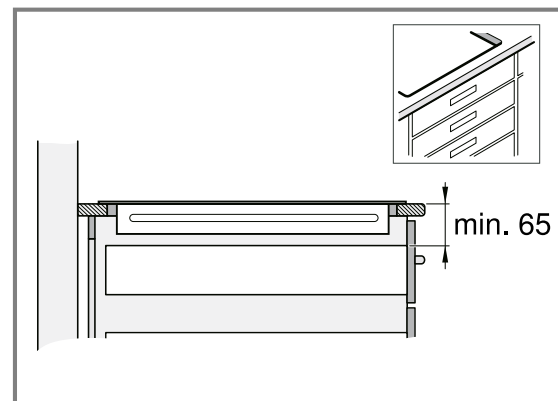

Installation above an oven

- To ensure good ventilation, the clearance between the top of the worktop and the surface of the oven front must be 30 mm and the minimum clearance between the oven and hob must be 5 mm.
- If the clearance between the hob and the oven needs to be increased, refer to the installation instructions for the oven.

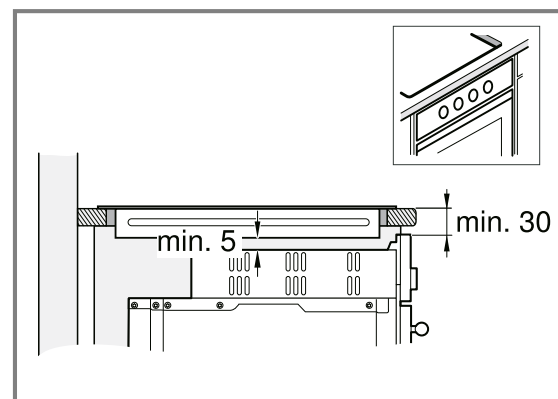

6.6 Inserting the hob

1. Adjust the hob in the front section of the built-in niche.

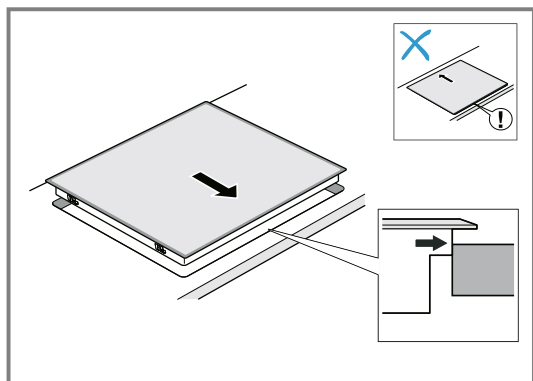

2. Insert the hob in the cut-out.

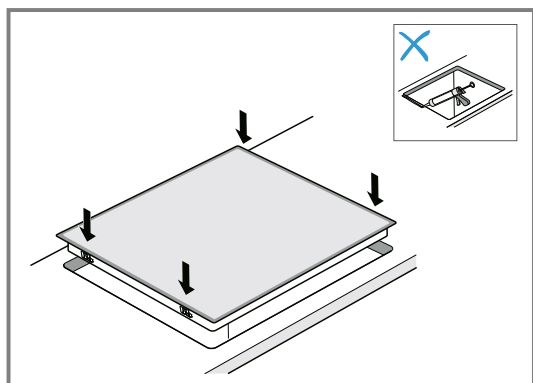

3. Seal the tile joints on tiled work surfaces with silicone rubber.

Note: Do not kink or trap the connection cable, and keep it away from sharp edges and hot parts.

6.7 Connecting the appliance

Requirement: Observe the connection data on the rating plate.

1. Only connect as shown in the circuit diagram:

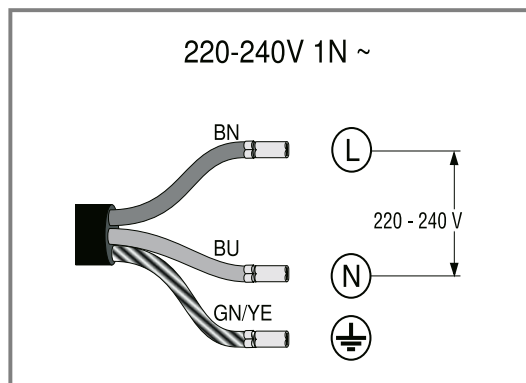

- BN: Brown
- BU: Blue
- GN/YE: Green and yellow

2. Check that the appliance is ready for operation: If **U40**, **E0513** or **E** appears on the appliance's display, the appliance is not connected correctly. Disconnect the appliance from the power supply and check the power cord connection at the mains supply.

6.8 Special combinations

If you install the hob above an oven made by another brand, use a wooden partition floor.

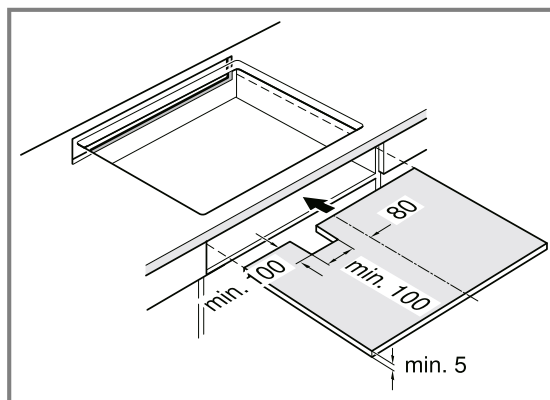

6.9 Removing the appliance

ATTENTION

Tools may damage the appliance.

- ▶ Never prise out the appliance from above.

1. Disconnect the appliance from the mains power supply.
2. Push out the hob from below.

7 Access additional information about the device

A digital version of the information for use is available on the web page, with more detailed information on:

- Preventing material damage
- Appliance functions
- Cooking recommendations
- Basic settings
- Cookware test
- Cleaning and maintenance
- Environmental protection and saving energy



You can find additional information and explanations online.

Scan the QR code on the title page or visit the sections on your appliance and Customer Service at siemens-home.bsh-group.com.

EN Manufactured by BSH Hausgeräte GmbH under the trademark licence of Siemens AG

Valid within Great Britain:
Imported to Great Britain by
BSH Home Appliances Ltd.
Grand Union House
Old Wolverton Road
Wolverton, Milton Keynes
MK12 5PT
United Kingdom

BSH Hausgeräte GmbH
Carl-Wery-Straße 34
81739 München, GERMANY
siemens-home.bsh-group.com



9001867170 (051128) REG25
en