



BOSCH

Register your
new device on
MyBosch now and
get free benefits:
[bosch-home.com/
welcome](https://bosch-home.com/welcome)



Refrigerator

KIF81H..

[en] Information for Use

Table of contents

1 Safety	3	7.3 Switching off the appliance	13
1.1 General information	3	7.4 Setting the temperature	14
1.2 Intended use	3	8 Additional functions	14
1.3 Restriction on user group	3	8.1 Super cooling	14
1.4 Safe transport	4	8.2 Door opening aid	14
1.5 Safe installation	4	9 Alarm	15
1.6 Safe use	5	9.1 Door alarm	15
1.7 Damaged appliance	6	10 Home Connect	15
2 Preventing material damage	7	10.1 Setting up the Home Connect app	16
3 Environmental protection and saving energy	8	10.2 Setting up Home Connect	16
3.1 Disposing of packaging	8	10.3 Installing updates for the Home Connect software	16
3.2 Saving energy	8	10.4 Resetting Home Connect set- tings	17
4 Installation and connection	8	10.5 Data protection	17
4.1 Scope of delivery	8	11 Refrigerator compartment	17
4.2 Criteria for the installation loc- ation	8	11.1 Tips for storing food in the re- frigerator compartment	18
4.3 Installing the appliance	9	11.2 Chill zones in the refrigerator compartment	18
4.4 Preparing the appliance for the first time	9	12 Cool-fresh compartment	18
4.5 Connecting the appliance to the electricity supply	9	12.1 Storage times in the cool- fresh compartment at 0 °C ...	18
5 Familiarising yourself with your appliance	10	13 Defrosting	18
5.1 Appliance	10	13.1 Defrosting in the refrigerator compartment	18
5.2 Control panel	11	13.2 Defrosting in the cool-fresh compartment	19
6 Features	12	14 Cleaning and servicing	19
6.1 Shelf	12	14.1 Preparing the appliance for cleaning	19
6.2 Variable shelf	12	14.2 Cleaning the appliance	19
6.3 Extendable shelf	12	14.3 Removing the fittings	20
6.4 Fruit and vegetable contain- er	12	14.4 Removing appliance com- ponents	21
6.5 Cool-fresh container	13	15 Troubleshooting	22
6.6 Butter and cheese compart- ment	13	15.1 Conducting an appliance self-test	25
6.7 Door tray	13		
6.8 Accessories	13		
7 Basic operation	13		
7.1 Switching on the appliance	13		
7.2 Operating tips	13		

16 Storage and disposal	25	17.1 Product number (E-Nr.) and production number (FD)	26
16.1 Taking the appliance out of operation	25	18 Technical data	26
16.2 Disposing of old appliance ...	25	19 Declaration of Conformity	27
17 Customer Service	26	19.1 Statement of Compliance for Great Britain	28



1 Safety

Observe the following safety instructions.

1.1 General information

- Read this instruction manual carefully.
- Keep the instruction manual and the product information safe for future reference or for the next owner.
- Do not connect the appliance if it has been damaged in transit.

1.2 Intended use

This appliance is only intended to be fully fitted in a kitchen.

Only use this appliance:

- For chilling food.
- in private households and in enclosed spaces in a domestic environment.
- Up to an altitude of 2000 m above sea level.

1.3 Restriction on user group

This appliance may be used by children aged 8 or over and by people who have reduced physical, sensory or mental abilities or inadequate experience and/or knowledge, provided that they are supervised or have been instructed on how to use the appliance safely and have understood the resulting dangers.

Do not let children play with the appliance.

Cleaning and user maintenance must not be performed by children unless they are being supervised.

Children above the age of three years old and younger than eight years old may load and unload the the fridge-freezer.

1.4 Safe transport

⚠ WARNING – Risk of injury!

The heavy weight of the appliance may result in injury when lifted.

- ▶ Do not lift the appliance on your own.

1.5 Safe installation

⚠ WARNING – Risk of electric shock!

Incorrect installation is dangerous.

- ▶ Connect and operate the appliance only in accordance with the specifications on the rating plate.
- ▶ Connect the appliance to a power supply with alternating current only via a properly installed socket with earthing.
- ▶ The protective conductor system of the domestic electrical installation must be properly installed.
- ▶ Never equip the appliance with an external switching device, e.g. a timer or remote control.
- ▶ When the appliance is installed, the mains plug of the power cord must be freely accessible. If free access is not possible, an isolating switch must be integrated into the permanent electrical installation according to the installation regulations.
- ▶ When installing the appliance, check that the power cable is not trapped or damaged.

If the insulation of the power cord is damaged, this is dangerous.

- ▶ Never let the power cord come into contact with heat sources.

⚠ WARNING – Risk of explosion!

If the appliance's ventilation openings are closed off, a leak in the refrigeration circuit may result in a flammable mixture of gas and air.

- ▶ Keep ventilation openings in the appliance casing or in the integrated casing clear of obstruction.

⚠ WARNING – Risk of fire!

It is dangerous to use an extended power cord and non-approved adapters.

- ▶ Do not use extension cables or multiple socket strips.
- ▶ Only use adapters and power cords approved by the manufacturer.

- ▶ If the power cord is too short and a longer one is not available, please contact an electrician to have the domestic installation adapted.

Portable multiple socket strips or portable power supply units may overheat and cause a fire.

- ▶ Do not place portable multiple socket strips or power supply units on the back of the appliance.

1.6 Safe use

⚠ WARNING – Risk of electric shock!

An ingress of moisture can cause an electric shock.

- ▶ Only use the appliance in enclosed spaces.
- ▶ Never expose the appliance to intense heat or humidity.
- ▶ Do not use steam- or high-pressure cleaners to clean the appliance.

⚠ WARNING – Risk of suffocation!

Children may put packaging material over their heads or wrap themselves up in it and suffocate.

- ▶ Keep packaging material away from children.
- ▶ Do not let children play with packaging material.

Children may breathe in or swallow small parts, causing them to suffocate.

- ▶ Keep small parts away from children.
- ▶ Do not let children play with small parts.

⚠ WARNING – Risk of explosion!

If the cooling circuit is damaged, flammable refrigerant may escape and explode.

- ▶ To accelerate the defrosting process, do not use any other mechanical devices or means other than those recommended by the manufacturer.
- ▶ If food is stuck to the freezer compartment, loosen it with a blunt object such as the handle of a wooden spoon.

Products which contain flammable propellants and explosive substances may explode, e.g. spray cans.

- ▶ Do not store products which contain flammable propellants (e.g. spray cans) or explosive substances in the appliance.

⚠ WARNING – Risk of fire!

Electrical devices within the appliance may cause a fire, e.g. heaters or electric ice makers.

- ▶ Do not operate electrical devices within the appliance.

⚠ WARNING – Risk of injury!

Containers that contain carbonated drinks may burst.

- ▶ Do not store containers that contain carbonated drinks in the cool-fresh compartment.

Injury to the eyes caused by escaping flammable refrigerant and hazardous gases.

- ▶ Do not damage the tubes of the refrigerant circuit or the insulation.

⚠ CAUTION – Risk of harm to health!

To prevent food from being contaminated, you must observe the following instructions.

- ▶ If the door is open for an extended period of time, this may lead to a considerable temperature increase in the compartments of the appliance.
- ▶ Regularly clean the surfaces that may come into contact with food and accessible drain systems.
- ▶ Store raw meat and fish in suitable containers in the refrigerator so that they do not touch or drip on other food.
- ▶ If the fridge/freezer is empty for an extended period of time, switch off the appliance, defrost it, clean it and leave the door open to prevent the formation of mould.

Metal or metal-style parts in the appliance may contain aluminium. If acidic food comes into contact with aluminium in the appliance, aluminium foil ions may pass into the food.

- ▶ Do not consume soiled food.

1.7 Damaged appliance

⚠ WARNING – Risk of electric shock!

If the appliance or the power cord is damaged, this is dangerous.

- ▶ Never operate a damaged appliance.
- ▶ Never pull on the power cord to unplug the appliance. Always unplug the appliance at the mains.

- ▶ If the appliance or the power cord is damaged, immediately unplug the power cord or switch off the fuse in the fuse box.
 - ▶ Call customer service. → *Page 26*
- Improper repairs are dangerous.
- ▶ Repairs to the appliance should only be carried out by trained specialist staff.
 - ▶ Only use genuine spare parts when repairing the appliance.
 - ▶ If the power cord of this appliance is damaged, it must be replaced by the manufacturer, the manufacturer's Customer Service or a similarly qualified person in order to prevent any risk.

⚠ WARNING – Risk of fire!



If the tubes are damaged, flammable refrigerant and harmful gases may escape and ignite.

- ▶ Keep naked flames and ignition sources away from the appliance.
- ▶ Ventilate the room.
- ▶ Switch off the appliance. → *Page 13*
- ▶ Unplug the mains plug from the mains or switch off the circuit breaker in the fuse box.
- ▶ Call customer service. → *Page 26*

2 Preventing material damage

ATTENTION

Using the base, runners or appliance doors as a seat surface or climbing surface may damage the appliance.

- ▶ Do not stand or support yourself on the base, runners or doors.
- Contamination with oil or fat may cause plastic parts and door seals to become porous.
- ▶ Keep plastic parts and door seals free of oil and grease.

Metal or metal-style parts in the appliance may contain aluminium. When aluminium comes into contact with acidic foods, it corrodes and discolours.

- ▶ Only store packaged food in the appliance.
- If you clean fittings and accessories in the dishwasher, this may cause them to become deformed or discoloured.
- ▶ Never clean fittings and accessory in the dishwasher.

3 Environmental protection and saving energy

3.1 Disposing of packaging

The packaging materials are environmentally compatible and can be recycled.

- ▶ Sort the individual components by type and dispose of them separately.

3.2 Saving energy

If you follow these instructions, your appliance will use less power.

Selecting the installation location

- Keep the appliance out of direct sunlight.
- Install the appliance as far away as possible from heating elements, cookers and other heat sources:
 - Maintain a 30 mm clearance to electric or gas cookers.
 - Maintain a 300 mm clearance to oil or solid-fuel cookers.
- Use a niche depth of 560 mm.
- Never cover or block the external ventilation openings.

Saving energy during use

Note: The arrangement of the fittings does not affect the energy consumption of the appliance.

- Open the appliance only briefly and then close it carefully.
- Never cover or block the interior ventilation openings or the exterior ventilation openings.
- Transport purchased food in a cool bag and place in the appliance quickly.

- Allow warm food and drinks to cool down before storing them.
- Thaw frozen food in the refrigerator compartment to utilise the low temperature of the food.
- Always leave some space between the food and to the back panel.

4 Installation and connection

4.1 Scope of delivery

After unpacking all parts, check for any transport damage and for completeness of delivery.

If you have any complaints, contact your dealer or our after-sales service → *Page 26*.

The delivery consists of the following:

- Built-in appliance
- Equipment and accessories¹
- Installation material
- Installation instructions
- User manual
- Customer service directory
- Warranty enclosure²
- Energy label
- Information on energy consumption and noises
- Information about Home Connect

4.2 Criteria for the installation location

WARNING

Risk of explosion!

If the appliance is in a space that is too small, a leak in the refrigeration circuit may result in a flammable mixture of gas and air.

- ▶ Only install the appliance in a space with a volume of at least

¹ Depending on the appliance specifications

² Not in all countries

1 m³ per 8 g refrigerant. The volume of refrigerant is indicated on the rating plate.

→ "Appliance", Fig. **1**/**7**

Page 11

The weight of the appliance ex works may be up to 70 kg depending on the model.

The subfloor must be sufficiently stable to bear the weight of the appliance.

This refrigerator is intended for use at ambient temperatures of 10 °C to 43 °C.

The appliance is fully functional within the permitted room temperature.

If the appliance is operated at colder room temperatures, the appliance will not be damaged up to a room temperature of 5 °C.

Niche dimensions

Observe the niche dimensions if you install your appliance in the niche. If this is not the case, problems may occur when installing the appliance.

Niche depth

Install the appliance in the recommended niche depth of 560 mm. If the niche depth is smaller, the energy consumption increases slightly. The niche depth must be a minimum 550 mm.

Niche width

An inside niche width of at least 560 mm is required for the appliance.

Over-and-under and side-by-side installation

If you want to install 2 refrigerating appliances one over the other or side by side, you must maintain a clearance of at least 150 mm between the appliances. Selected appliances can be installed without a minimum clearance. Ask your dealer or kitchen planner about this.

4.3 Installing the appliance

- ▶ Install the appliance in accordance with the enclosed installation instructions.

4.4 Preparing the appliance for the first time

1. Remove the informative material.
2. Remove the protective foil and transit bolts, e.g. remove the adhesive strips and carton.
3. Clean the appliance for the first time. → Page 19

4.5 Connecting the appliance to the electricity supply

1. Insert the mains plug of the appliance's power cable in a socket nearby.
The connection data of the appliance can be found on the rating plate.
→ "Appliance", Fig. **1**/**7**
Page 11
2. Check the mains plug is inserted properly.
- ✓ The appliance is now ready for use.

5 Familiarising yourself with your appliance

5.1 Appliance

You can find an overview of the parts of your appliance here.

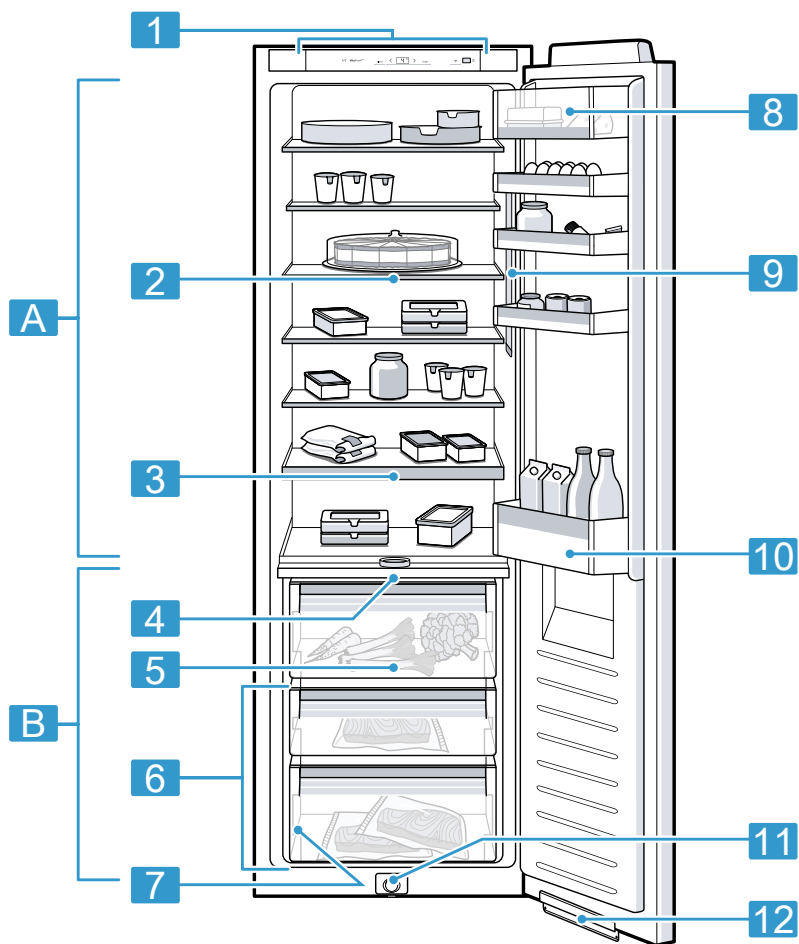

1

Deviations between your appliance and the diagrams may differ with regard to their features and size.

A Refrigerator compartment
→ Page 17

B Cool-fresh compartment
→ Page 18

1 Control panel → Page 11

2	Variable shelf → <i>Page 12</i> ¹
3	Extendable shelf → <i>Page 12</i> ¹
4	Partition with humidity controller → <i>Page 12</i>
5	Fruit and vegetable container → <i>Page 12</i>
6	Cool-fresh container → <i>Page 13</i>

7	Rating plate → <i>Page 26</i>
8	Butter and cheese compartment → <i>Page 13</i> ¹
9	Lighting
10	Door tray for large bottles → <i>Page 13</i>
11	Door opening aid → <i>Page 14</i>
12	Pressure plate

5.2 Control panel

You can use the control panel to configure all functions of your appliance and to obtain information about the operating status.

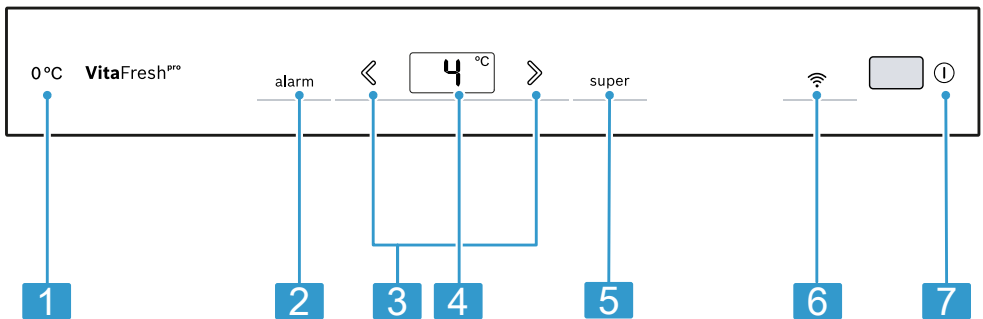

2	
1	0 °C lights up when the appliance is operating.
2	alarm switches the warning signal off.
3	</> sets the temperature of the refrigerator compartment.
4	Displays the set temperature for the refrigerator compartment in °C.
5	super switches Super cooling on or off.
6	Wi-Fi opens the menu for setting Home Connect.
7	ⓘ switches the appliance on or off.

¹ Depending on the appliance specifications

6 Features

The features of your appliance depend on the model.

6.1 Shelf

To vary the shelf as required, you can remove the shelf and re-insert it elsewhere.

→ "Removing the shelf", Page 20

6.2 Variable shelf

Use the variable shelf to store tall items, e.g. cans or bottles, on the shelf below.

You can remove the front section of the variable shelf and slide it below the rear part of the shelf.

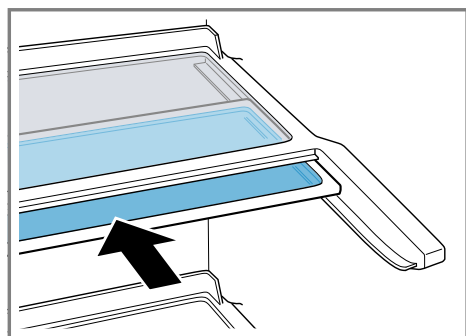

6.3 Extendable shelf

In order to achieve an improved overview and to remove food more quickly, pull out the extendable shelf.



6.4 Fruit and vegetable container

Store fresh fruit and vegetables loose in the fruit and vegetable container. Cover any chopped fruit and vegetables, or store in air-tight packaging. You can adjust the humidity in the fruit and vegetable container via the

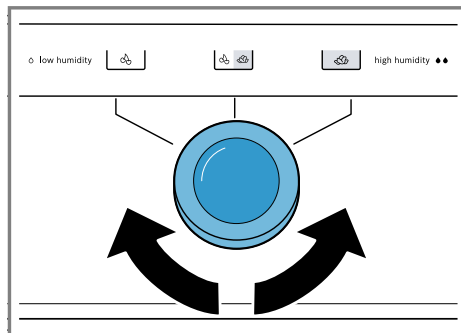
humidity controller on the partition and a special seal.



The air humidity in the fruit and vegetable container can be set according to the type and amount of food to be stored by turning the humidity controller:

- Turn to the left for low humidity  when primarily storing fruit or if the appliance is very full.
- Turn to the middle for medium humidity  for a mixed load.
- Turn to the right for high humidity  when primarily storing vegetables or when the appliance is not very full.

Condensation may form in the fruit and vegetable container depending on the food and quantity stored.

Remove the condensation with a dry cloth and adjust the air humidity to a lower setting using the humidity controller.

To ensure that the quality and aroma are retained, store fruit and vegetables that are sensitive to cold outside of the appliance at temperatures of approx. 8 °C to 12 °C, e.g. pineapple, bananas, citrus fruits, cucumbers, courgettes, peppers, tomatoes and potatoes.

6.5 Cool-fresh container

Use the lower temperatures in the cool-fresh container to store highly perishable food, e.g. fish, meat and sausages.

6.6 Butter and cheese compartment

Store butter and hard cheese in the butter and cheese compartment.

6.7 Door tray

To adjust the door tray as required, you can remove the door tray and re-insert elsewhere.

→ "Removing door tray", Page 20

6.8 Accessories

Use original accessories. These have been made especially for your appliance.

The accessories for your appliance depend on the model.

Egg tray

Store eggs safely on the egg tray.

Bottle holder

The bottle holder prevents bottles from falling over when the appliance door is opened and closed.

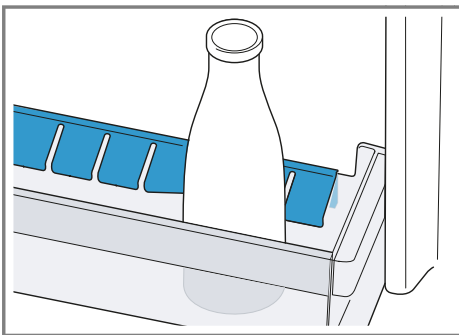

7 Basic operation

7.1 Switching on the appliance

1. Press ①.
- ✓ The appliance begins to cool.
2. Set the required temperature.
→ Page 14

7.2 Operating tips

- Once you have switched on the appliance, the set temperature is only reached after several hours. Do not put any food in the appliance until the set temperature has been reached.
- The housing to the left, the right and beneath the cool-fresh compartment may heat up slightly temporarily. This prevents condensation in the area of the door seal.
- When closing the door, make sure that the door is not blocked by stored items.
- When you close the door, a vacuum may be created. The door is then difficult to open again. Wait a moment until the vacuum is offset.
- The temperature in the appliance varies due to the following conditions:
 - How often the appliance is opened
 - Load capacity
 - Temperature of newly stored food
 - Ambient temperature
 - Direct sunlight

7.3 Switching off the appliance

- ▶ Press ①.

7.4 Setting the temperature

Setting the refrigerator compartment temperature

- ▶ Press \llcorner/\triangleright repeatedly until the temperature display shows the required temperature setting.
The recommended temperature in the refrigerator compartment is 4 °C.

Setting the cool-fresh compartment temperature

Note: The standard setting of the cool-fresh compartment is preset at 0. Setting 0 corresponds to a temperature of around 0 °C. You can set the temperature in the cool-fresh compartment to 3 settings warmer or colder.

Tip: If frost forms on the food items in the cool-fresh compartment, set a higher cool-fresh compartment temperature.

1. Press and hold **super** until the temperature display flashes.
 2. Press \llcorner/\triangleright to change the setting.
 - Setting -3 corresponds to the coldest setting.
 - Setting +3 corresponds to the warmest setting.
- ✓ The selected setting is saved after one minute.

8 Additional functions

Find out which additional functions can be used for your appliance.

8.1 Super cooling

With Super cooling, the refrigerator compartment cools as cold as possible.

Switch on Super cooling before placing large quantities of food in the refrigerator compartment.

Note: When Super cooling is switched on, increased noise may occur.

Switching on Super cooling

- ▶ Press **super**.
- ✓ "super" lights up.

Note: After approx. 15 hours, the appliance switches to normal operation.

Switching off Super cooling

- ▶ Press **super**.
- ✓ The previously set temperature is displayed.

8.2 Door opening aid

The door-opening aid supports you in opening the door.

Opening the door using the door-opening aid

ATTENTION

Repeatedly closing the door prematurely may lead to wear or failure of the door-opening aid.

Never close the door while the door-opening aid is extended.

- ▶ If you have nevertheless closed the door, leave it closed for 5 minutes. The door-opening aid is realigned.
1. Install the pressure plate on the door-opening aid in accordance with the enclosed installation instructions.



2. Push the door in the middle.
 - ✓ The door-opening aid extends and opens the door slightly.
 - ✓ The button is lit while the door-opening aid is extending.
3. Manually open the door. If you do not open the door any further within 3 seconds, the door-opening aid retracts and the door closes.

Setting the compressive force of the door-opening aid

The compressive force is the force that you must apply in order to trigger the door-opening aid.

1. Open the door, wait until the door-opening aid is retracted, and close the door.
2. Open the door and press and hold **alarm** for 2 seconds.
3. Press \llcorner/\triangleright repeatedly until the required compressive force is displayed.

1	Low compressive force
2	Medium compressive force
3	High compressive force

- ✓ The compressive force of the door-opening aid is set and the temperature that was previously set is displayed.

Switching off the door-opening aid

1. Open the door, wait until the door-opening aid is retracted, and close the door.
2. Open the door and press and hold **alarm** for 2 seconds.

3. Press \llcorner repeatedly until the temperature display shows "0".
 - ✓ The door-opening aid is switched off and the temperature that was previously set is displayed again.

Switching on the door-opening aid

1. Open the door, wait until the door-opening aid is retracted, and close the door.
2. Open the door and press and hold **alarm** for 2 seconds.
3. Press \triangleright repeatedly until the temperature display shows the required compressive force.
 - *"Setting the compressive force of the door-opening aid", Page 15*
 - ✓ The door-opening aid is switched on with the appropriate compressive force and the temperature display shows the temperature that was previously set.

9 Alarm

9.1 Door alarm

If the appliance door is open for a while, the door alarm switches on. A warning tone sounds.

Switching off the door alarm

- ▶ Close the appliance door or press **alarm**.
- ✓ The warning tone is switched off.

10 Home Connect

This appliance is network-capable. Connect your appliance to a mobile device to control its functions via the Home Connect app. The Home Connect services are not available in every country. The availability of the Home Connect function depends on the availability of

Home Connect services in your country. You can find information about this at: www.home-connect.com.

To be able to use Home Connect, you must first set up the connection to the WLAN home network (Wi-Fi¹) and to the Home Connect app.

After switching on the appliance, wait at least 2 minutes until internal device initialisation is complete. Only then should you set up Home Connect.

The Home Connect app guides you through the entire login process. Follow the instructions in the Home Connect app to configure the settings.

Tip: Please also follow the instructions in the Home Connect app.

Notes

- Please note the safety precautions in this instruction manual and make sure that they are also observed when operating the appliance via the Home Connect app.
→ "Safety", Page 3
- Operating the appliance on the appliance itself always takes priority. During this time it is not possible to operate the appliance using the Home Connect app.

10.1 Setting up the Home Connect app

1. Install the Home Connect app on your mobile device.
2. Start the Home Connect app and set up access for Home Connect. The Home Connect app guides you through the entire login process.

10.2 Setting up Home Connect

Requirement: The appliance is receiving signals from the WLAN home network (Wi-Fi) at its installation location.

1. Scan the following QR code.



You can install the Home Connect app and connect your appliance via the QR code.

2. Follow the instructions in the Home Connect app.

10.3 Installing updates for the Home Connect software

The appliance searches for updates to the Home Connect software at regular intervals.

Note: If updates are available, the temperature display shows "UP". To reset the update and the temperature display to the set temperature, press any touch field.

1. Press .
- ✓ The temperature display shows "Cn".
2. Press **super** repeatedly until the temperature display shows "UP".

¹ Wi-Fi is a registered trademark of the Wi-Fi Alliance.

3. Press **»**.
 - ✓ The temperature display shows an animation.
 - ✓ The update is installed.
 - ✓ The control panel is locked during the installation.
 - ✓ If the installation is successful, the temperature display shows "On".
4. If the temperature display shows "Er", the appliance was unable to install the update.
 - ▶ Repeat the process at a later point.
5. If the update cannot be completed after several attempts, contact customer service → *Page 26* .

10.4 Resetting Home Connect settings

If your appliance experiences connection problems with the WLAN home network (Wi-Fi) or your appliance wants to log into a different WLAN home network (Wi-Fi), you can reset the Home Connect settings.

1. Press **📶**.
 - ✓ The temperature display shows "Cn".
2. Press **super** repeatedly until the temperature display shows "rE".
3. Press **»**.
 - ✓ The temperature display shows an animation for 15 seconds.
 - ✓ The temperature display shows "On".
 - ✓ The Home Connect settings have been reset.

10.5 Data protection

Please see the information on data protection.

The first time your appliance is registered on a home network connec-

ted to the Internet, your appliance will transmit the following types of data to the Home Connect server (initial registration):

- Unique appliance identification (consisting of appliance codes as well as the MAC address of the installed Wi-Fi communication module).
- Security certificate of the Wi-Fi communication module (to ensure a secure data connection).
- The current software and hardware version of your appliance.
- Status of any previous resetting to factory settings.

This initial registration prepares the Home Connect functions for use and is only required when you want to use the Home Connect functions for the first time.

Note: Please note that the Home Connect functions can only be utilised with the Home Connect app. Information on data protection can be retrieved in the Home Connect app.

11 Refrigerator compartment

You can keep dairy products, eggs, prepared meals, pastries, open preserves and hard cheese in the refrigerator compartment.

The temperature can be set from 3 °C to 8 °C.

The refrigerator compartment can also be used to store highly perishable foods in the short to medium term. The lower the selected temperature, the longer the food remains fresh.

11.1 Tips for storing food in the refrigerator compartment

- Only store food when fresh and undamaged.
- Store food covered or in air-tight packaging.
- To avoid impeding the circulation of air and to prevent food from freezing, do not place food so that it has direct contact with the back wall.
- Allow hot food and drinks to cool down first before placing in the appliance.
- Observe the best-before date or use-by date specified by the manufacturer.

11.2 Chill zones in the refrigerator compartment

The air circulation in the refrigerator compartment creates different chill zones.

Coldest zone

The coldest zone is on the partition and in the door tray for large bottles.

Tip: Store highly perishable food such as fish, sausages and meat in the cool-fresh compartment.

→ "*Cool-fresh compartment*",

Page 18

Warmest zone

The warmest zone is at the very top of the door.

Tip: Store food that does not spoil easily in the warmest zone, e.g. hard cheese and butter. Cheese can then continue to release its aroma and the butter will still be easy to spread.

12 Cool-fresh compartment

In the cool-fresh compartment, you can keep fresh food fresh up to three times longer than in the refrigerator compartment.

The temperature in the cool-fresh compartment is kept at around 0 °C. Storing food in the fresh compartment retains the quality of the food better. The low temperature and the optimum moisture provide ideal storage conditions for fresh food.

12.1 Storage times in the cool-fresh compartment at 0 °C

The storage times are dependent on the original quality of your food.

Food	Storage time
Fresh fish, seafood	up to 3 days
Poultry, meat (boiled/fried)	up to 5 days
Beef, pork, lamb, sausage (cold meat)	up to 7 days
Smoked fish, broccoli	up to 14 days
Salad greens, fennel, apricots, plums	up to 21 days
Soft cheese, yoghurt, quark, buttermilk, cauliflower	up to 30 days

13 Defrosting

13.1 Defrosting in the refrigerator compartment

The refrigerator compartment in your appliance defrosts automatically.

13.2 Defrosting in the cool-fresh compartment

The cool-fresh compartment in your appliance defrosts automatically.

14 Cleaning and servicing

To keep your appliance working efficiently for a long time, it is important to clean and maintain it carefully. Customer Service must clean inaccessible points. Cleaning by customer service can give rise to costs.

14.1 Preparing the appliance for cleaning

1. Switch off the appliance.
→ *Page 13*
2. Disconnect the appliance from the power supply.
Unplug the appliance from the mains or switch off the circuit breaker in the fuse box.
3. Take out all of the food and store it in a cool place.
Place ice packs (if available) onto the food.
4. If there is a layer of hoarfrost, allow this to defrost.
5. Remove all fittings and accessories from the appliance.
→ *Page 20*
6. Remove the partition. → *Page 21*
7. Remove the cover. → *Page 21*
8. Remove the telescopic rails.
→ *Page 21*

14.2 Cleaning the appliance

WARNING

Risk of electric shock!

An ingress of moisture can cause an electric shock.

- ▶ Do not use steam- or high-pressure cleaners to clean the appliance.

Liquid in the lighting or in the controls can be dangerous.

- ▶ The rinsing water must not drip into the lighting or controls.

ATTENTION

Unsuitable cleaning products may damage the surfaces of the appliance.

- ▶ Do not use hard scouring pads or cleaning sponges.
- ▶ Do not use harsh or abrasive detergents.
- ▶ Do not use cleaning products with a high alcohol content.

If you clean fittings and accessories in the dishwasher, this may cause them to become deformed or discoloured.

- ▶ Never clean fittings and accessory in the dishwasher.

1. Prepare the appliance for cleaning.
→ *Page 19*
2. Clean the appliance, the fittings, the accessories, the removable parts and the door seals with a dish cloth, lukewarm water and a little pH-neutral detergent.
3. Dry thoroughly with a soft, dry cloth.
4. Insert the fittings and install the removable appliance parts.
5. Electrically connect the appliance.
→ *Page 9*
6. Switch on the appliance.
→ *Page 13*
7. Putting the food into the appliance.

14.3 Removing the fittings

If you want to clean the fittings thoroughly, remove these from your appliance.

Removing the shelf

- ▶ Pull out and remove the shelf.

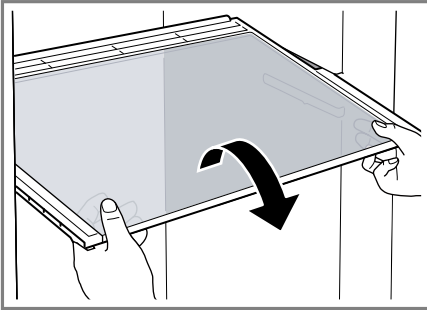

Removing the extendable shelf

1. Firmly pull out the extendable shelf until the locking catch is released.

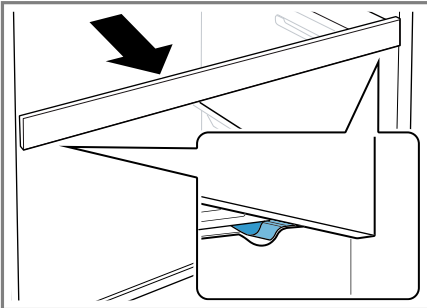

2. Lower the extendable shelf and swing it out to the side.

Removing door tray

- ▶ Lift the door tray and remove it.

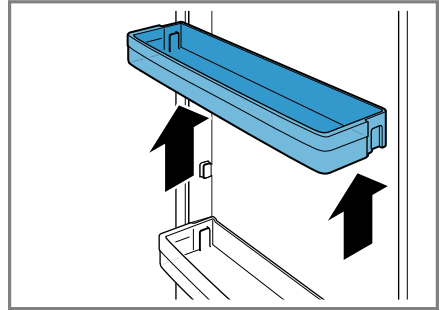

Removing the fruit and vegetable container

- ▶ Tilt the fruit and vegetable container forwards ① and remove it ②.

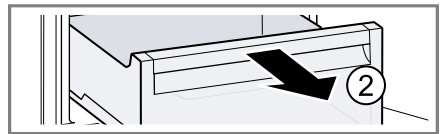
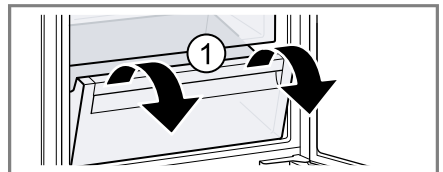

Removing the cool-fresh container

- ▶ Tilt the cool-fresh container forwards ① and remove it ②.

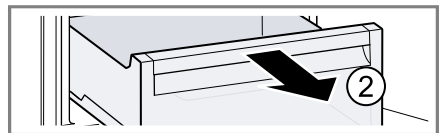
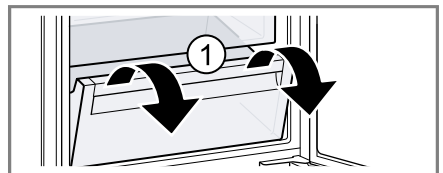

14.4 Removing appliance components

If you want to clean your appliance thoroughly, you can remove certain components from your appliance.

Partition and cover of the fruit and vegetable container

You can remove the partition and the cover of the fruit and vegetable container in order to clean it thoroughly.

Removing the partition

1. Remove the glass plate from the partition.

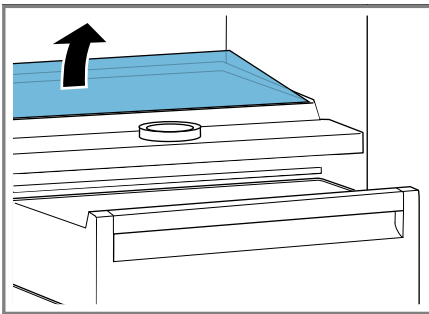

2. Remove the fruit and vegetable container.
3. Press the lever on the underside on both sides ① and pull the partition forwards ②.

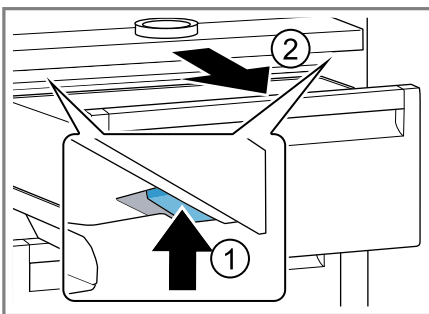

4. Lift the partition and swivel it out to the side.

Removing the cover

- ▶ Lift the cover of the fruit and vegetable container, pull it forwards and swivel it out to the side.

Fitting the partition and cover

1. Insert the cover for the fruit and vegetable container.
2. Insert the partition.

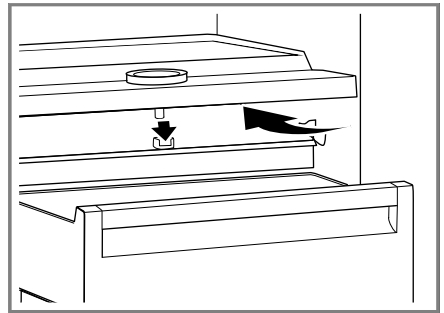

3. Place the glass plate on the partition.

Telescopic rails

You can remove the telescopic rails in order to clean them thoroughly.

Removing telescopic rails

1. Pull out the telescopic rail.

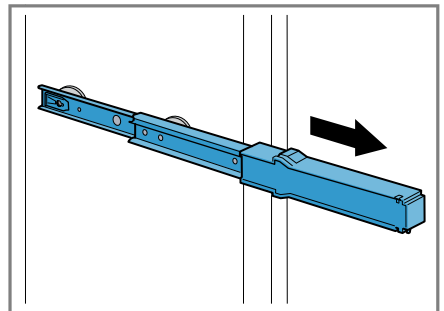

2. Move the lock in the direction of the arrow ① and loosen the pin from the rear ②.

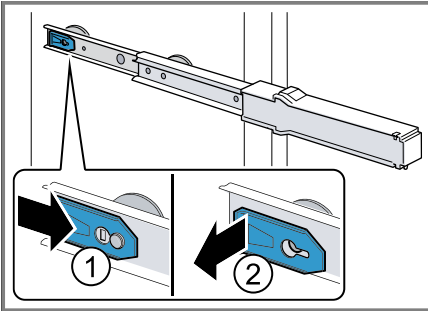

3. Push in the telescopic rail.
4. Push the telescopic rail backwards above the rear pin ① and disengage ②.

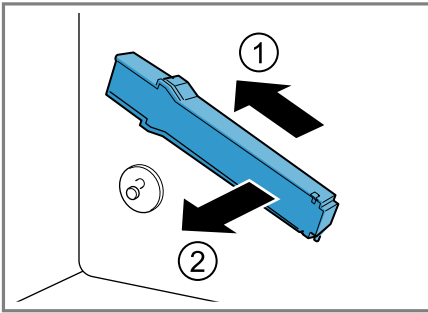

Installing telescopic rails

1. Place the extended telescopic rail on the front pin ① and pull it forwards slightly to lock in place ②.

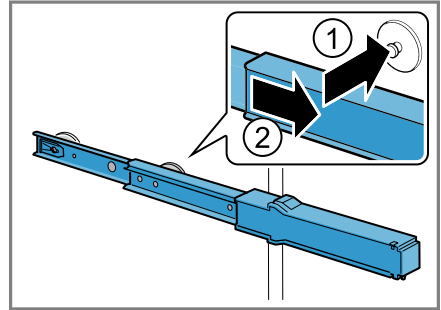

2. Place the telescopic rail on the rear pin ① and push the locking mechanism back ②.

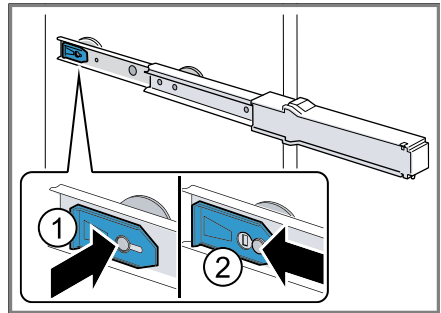

15 Troubleshooting



You can rectify minor faults on your appliance yourself. Read the troubleshooting information before contacting after-sales service. This will avoid unnecessary costs.

⚠ WARNING

Risk of electric shock!

Improper repairs are dangerous.

- ▶ Repairs to the appliance should only be carried out by trained specialist staff.
- ▶ Only use genuine spare parts when repairing the appliance.
- ▶ If the power cord of this appliance is damaged, it must be replaced by the manufacturer, the manufacturer's Customer Service or a similarly qualified person in order to prevent any risk.

Fault	Cause and troubleshooting
The appliance is not cooling, the displays and lighting are lit.	<p>Showroom mode is switched on.</p> <ul style="list-style-type: none"> ▶ Carry out the appliance self-test. → <i>Page 25</i> ✓ Once the appliance self-test has ended, the appliance switches to normal operation.
The LED lighting does not work.	<p>Different causes are possible.</p> <ul style="list-style-type: none"> ▶ Call customer service. The customer service number can be found in the enclosed customer service directory.
The refrigeration unit is switching on more frequently and for longer.	<p>The appliance has been opened frequently.</p> <ul style="list-style-type: none"> ▶ Do not open appliance door unnecessarily. <hr/> <p>External ventilation openings are covered up.</p> <ul style="list-style-type: none"> ▶ Remove any obstructions from in front of the external ventilation openings. <hr/> <p>Not a fault. Modern refrigeration machines switch on more frequently and have different power levels to cool more efficiently.</p>  <ul style="list-style-type: none"> ▶ Remove any obstructions from in front of the external ventilation openings. ▶ Install the appliance as far away as possible from heating elements, cookers and other heat sources. Avoid prolonged exposure of the appliance to direct sunlight. ▶ Only open the appliance door as briefly as necessary. ▶ Allow hot food and drinks to cool down first before storing in the appliance.
Door-opening aid does not work.	<p>Appliance is installed too deep in the recess.</p> <ol style="list-style-type: none"> 1. Push the appliance max. 41 mm behind the front edge of the recess. 2. Ensure that the front panel is 2 mm away from the recess. 

Fault	Cause and troubleshooting
Door-opening aid does not work.	<p>Stop buffers have been glued between the appliance and the door.</p> <ul style="list-style-type: none"> ▶ Remove the stop buffers or adjust the distance between the front panel and the stop buffers in accordance with the enclosed installation instructions to create a distance of at least 2 mm.
	<p>Pressure plate missing on the underside of the appliance door.</p> <ul style="list-style-type: none"> ▶ Install the pressure plate on the underside of the appliance door in accordance with the enclosed installation instructions.
	
Home Connect is not working properly.	<p>Different causes are possible.</p> <ul style="list-style-type: none"> ▶ Go to www.home-connect.com.
"E" or "d" appears on the temperature display.	<p>The electronics have detected a fault.</p> <ol style="list-style-type: none"> 1. Switch off the appliance. → <i>Page 13</i> 2. Disconnect the appliance from the mains. Unplug the appliance from the mains or switch off the circuit breaker in the fuse box. 3. Reconnect the appliance after five minutes. 4. If the message still appears on the display, call Customer Service. The customer service number can be found in the enclosed customer service directory.
A warning signal sounds and "alarm" lights up.	<p>Different causes are possible.</p> <ul style="list-style-type: none"> ▶ Press alarm. ✓ The alarm is switched off.
	<p>The appliance door is open.</p> <ul style="list-style-type: none"> ▶ Close the appliance door.
The temperature differs greatly from the setting.	<p>Different causes are possible.</p> <ol style="list-style-type: none"> 1. Switch off the appliance. → <i>Page 13</i> 2. Switch the appliance back on after five minutes. → <i>Page 13</i> <ul style="list-style-type: none"> ▶ If the temperature is too warm, check the temperature again after a couple of hours. ▶ If the temperature is too cold, check the temperature again on the following day.

Fault	Cause and troubleshooting
The appliance hums, bubbles, buzzes, gargles or clicks.	Not a fault. A motor is running, e.g. refrigerating unit, fan. Refrigerant flows through the pipes. The motor, switches or solenoid valves are switching on or off. No action required.
The appliance makes noises.	Fittings wobble or stick. ▶ Check the removable fittings and, if required, replace these.
	Bottles or containers are touching. ▶ Move the bottles or containers away from each other.

15.1 Conducting an appliance self-test

Your appliance has an appliance self-test which displays faults that can be eliminated by your customer service.

1. Switch off the appliance.
→ *Page 13*
2. Switch the appliance back on after approx. five minutes. → *Page 13*
3. Within the first 10 seconds after switching on, press and hold **super** 3 to 5 seconds.
 - ✓ The appliance self-test starts.
 - ✓ While the appliance self-test is running, a long audible signal sounds.
 - ✓ If, at the end of the appliance self-test, 2 audible signals sound and the temperature display indicates the set temperature, the temperature sensors on your appliance are OK. The appliance switches to normal operation.
 - ✓ If, at the end of the appliance self-test, 5 audible signals sound and "super" flashes for 10 seconds, inform customer service.

16 Storage and disposal

16.1 Taking the appliance out of operation

1. Switch off the appliance.
→ *Page 13*
2. Disconnect the appliance from the power supply.
Unplug the appliance from the mains or switch off the circuit breaker in the fuse box.
3. Remove all of the food.
4. Defrost the appliance. → *Page 18*
5. Clean the appliance. → *Page 19*
6. To guarantee the ventilation inside the appliance, leave the appliance open.

16.2 Disposing of old appliance

Valuable raw materials can be re-used by recycling.

WARNING

Risk of harm to health!

Children can lock themselves in the appliance, thereby putting their lives at risk.

- ▶ Leave shelves and containers inside the appliance to prevent children from climbing in.
- ▶ Keep children away from the redundant appliance.

⚠ WARNING

Risk of fire!

If the tubes are damaged, flammable refrigerant and harmful gases may escape and ignite.

► Do not damage the tubes of the refrigerant circuit or the insulation.

1. Unplug the appliance from the mains.
2. Cut through the power cord.
3. Dispose of the appliance in an environmentally friendly manner. Information about current disposal methods are available from your specialist dealer or local authority.



This appliance is labelled in accordance with European Directive 2012/19/EU concerning used electrical and electronic appliances (waste electrical and electronic equipment - WEEE). The guideline determines the framework for the return and recycling of used appliances as applicable throughout the EU.

17 Customer Service

Function-relevant genuine spare parts according to the corresponding Eco-design Order can be obtained from Customer Service for a period of at least 10 years from the date on which your appliance was placed on the market within the European Economic Area.

Note: Under the terms of the manufacturer's warranty applicable to the location, the use of Customer Service is free of charge. The minimum dura-

tion of the warranty (manufacturer's warranty for private consumers) in the European Economic Area is 2 years according to the terms of warranty applicable to the location. The terms of warranty do not affect other rights or claims held by yourself under local legislation.

Detailed information about the warranty period and the warranty conditions in your country is available via the QR code on the enclosed document on service contacts and warranty conditions, from our customer service or on our website.

If you contact Customer Service, you will require the product number (E-Nr.) and the production number (FD) of your appliance.

You can find the contact details for our customer service via the QR code on the enclosed document on service contacts and warranty conditions or on our website.

17.1 Product number (E-Nr.) and production number (FD)

You can find the product number (E-Nr.) and the production number (FD) on the appliance's rating plate.

→ "Appliance", Fig. **1**/**7** Page 11
 Make a note of your appliance's details and the Customer Service telephone number to find them again quickly.

18 Technical data

Refrigerant, cubic capacity and further technical specifications can be found on the rating plate.

→ "Appliance", Fig. **1**/**7** Page 11
 This product contains a light source from energy efficiency class F. The

light source is available as a spare part and should only be replaced by trained specialist staff. You can find more information about your model online at <https://eprel.ec.europa.eu/>¹. This web address is linked to the official EU EPREL product database. Please

then follow the instructions on searching for the model. The model identifier is made up of the characters before the slash in the product number (E-Nr.) on the rating plate. Alternatively, you can also find the model identifier in the first line of the EU energy label.

19 Declaration of Conformity

BSH Hausgeräte GmbH hereby declares that the appliance with Home Connect functionality conforms to the basic requirements and other relevant provisions of Directive 2014/53/EU.

A detailed RED Declaration of Conformity can be found online at www.bosch-home.com among the additional documents on the product page for your appliance.



Hereby, BSH Hausgeräte GmbH declares that the appliance with Home Connect functionality is in compliance with relevant statutory requirements.²

A detailed Declaration of Conformity can be found online at www.bosch-home.co.uk among the additional documents on the product page for your appliance.²



2.4 GHz band (2400–2483.5 MHz): Max. 100 mW
5-GHz band (5150–5350 MHz + 5470–5725 MHz): max. 50 mW

	BE	BG	CZ	DK	DE	EE	IE	EL	ES
	FR	HR	IT	CY	LI	LV	LT	LU	HU
	MT	NL	AT	PL	PT	RO	SI	SK	FI
	SE	NO	CH	TR	IS	UK (NI)			

5 GHz WLAN (Wi-Fi): For indoor use only.

AL	BA	MD	ME	MK	RS	UK	UA
----	----	----	----	----	----	----	----

5 GHz WLAN (Wi-Fi): For indoor use only.

¹ Only applies to countries in the European Economic Area

² Only applies to Great Britain

19.1 Statement of Compliance for Great Britain

The full Statement of Compliance according to the Product Security and Telecommunications Infrastructure (Security Requirements for Relevant Connectable Products) Regulations 2023 can be found online at www.bosch-home.co.uk among the additional documents on the product page for your appliance.

Product type

This statement of compliance covers the products described in this information for use whose model identifier group is seen on the title page. The full model identifier is made up of the characters before the slash in the product number (E no.) which can be found on the rating plate. Alternatively, you can also find the model identifier in the first line of the UK Energy Label.

Name and address of manufacturer

BSH Hausgeräte GmbH, Carl-Wery-Strasse 34, 81739 München, Germany

This statement of compliance is prepared by the manufacturer.

The manufacturer, BSH Hausgeräte GmbH deems that it has complied with

- provision 5.1-1 of ETSI EN 303 645 v2.1.1 and, where relevant, provision 5.1-2 of ETSI EN 303 645 v2.1.1;
- provision 5.2-1 of ETSI EN 303 645 v2.1.1;
- provision 5.3-13 of ETSI EN 303 645 v2.1.1.

Support period

BSH Hausgeräte GmbH will provide security updates that are necessary to maintain the main functions free of charge until at least 28/02/2034.



Thank you for buying a Bosch Home Appliance!

Register your new device on MyBosch now and profit directly from:

- **Expert tips & tricks for your appliance**
- **Warranty extension options**
- **Discounts for accessories & spare-parts**
- **Digital manual and all appliance data at hand**
- **Easy access to Bosch Home Appliances Service**

Free and easy registration – also on mobile phones:

www.bosch-home.com/welcome



Looking for help? You'll find it here.

Expert advice for your Bosch home appliances, help with problems or a repair from Bosch experts.

Find out everything about the many ways Bosch can support you:

www.bosch-home.com/service

Contact data of all countries are listed in the attached service directory.

BSH Hausgeräte GmbH

Carl-Wery-Straße 34
81739 München, GERMANY
www.bosch-home.com

A Bosch Company

Valid within Great Britain:
Imported to Great Britain by
BSH Home Appliances Ltd.
Grand Union House
Old Wolverton Road
Wolverton, Milton Keynes
MK12 5PT
United Kingdom



9001752656 (050526)

en