



SIEMENS

Refrigerator

KI.R..

en User manual



Register your product on My Siemens and discover exclusive services and offers.
siemens-home.bsh-group.com/welcome

The future moving in.

Siemens Home Appliances

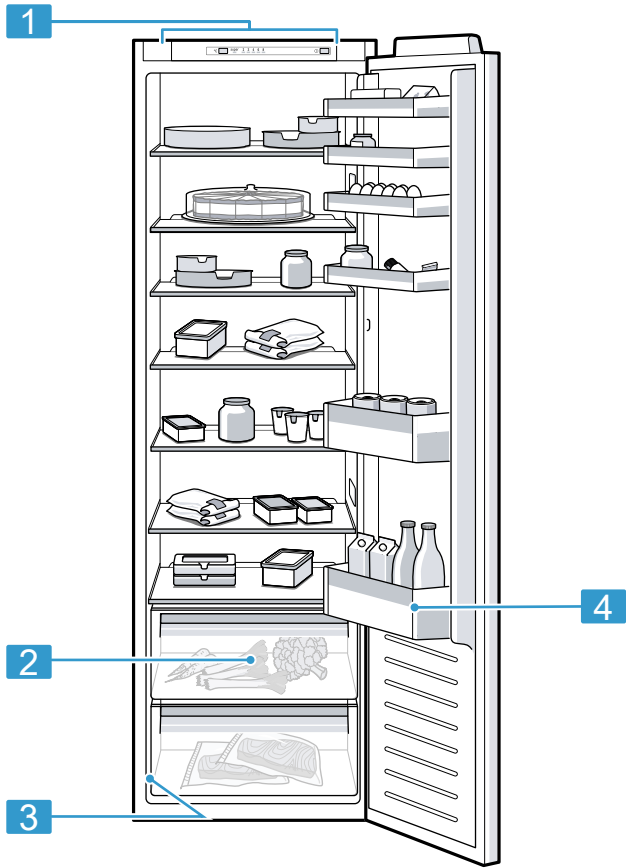

1

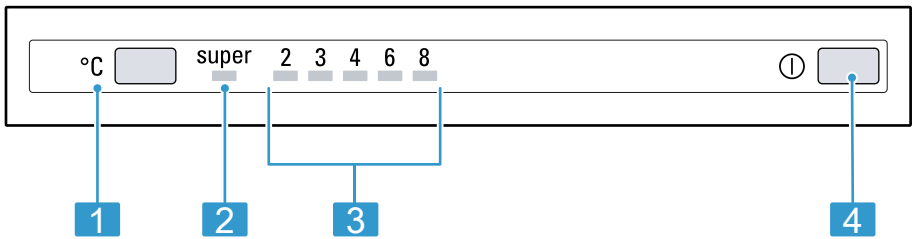

2

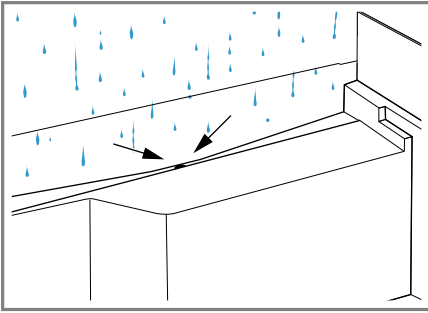

3

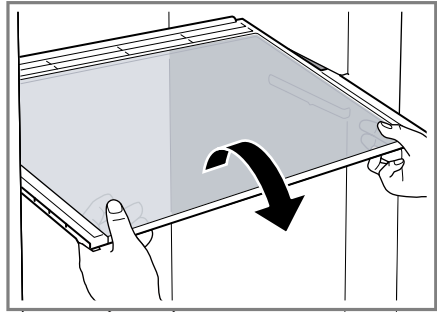

4

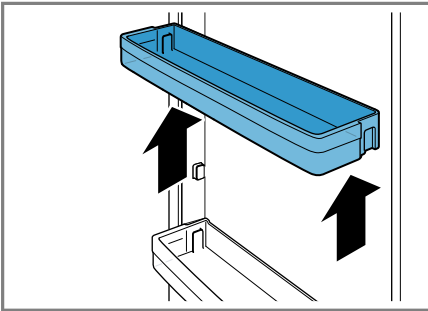

5

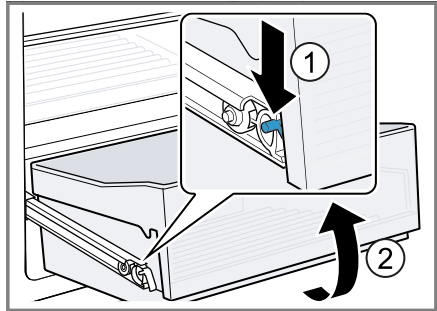

6

Table of contents

Safety	5	Additional functions	13
General information	5	Super cooling	13
Intended use.....	5	Refrigerator compartment	13
Restriction on user group.....	5	Tips for storing food in the refrigerator compartment	14
Safe transport.....	5	Chill zones in the refrigerator compartment	14
Safe installation	6	"OK" sticker	14
Safe use	7	Defrosting	14
Damaged appliance.....	8	Defrosting in the refrigerator compartment	14
Preventing material damage	10	Cleaning and servicing	15
Environmental protection and saving energy	10	Care instructions for stainless steel surfaces	15
Disposing of packaging	10	Preparing the appliance for cleaning	15
Saving energy.....	10	Cleaning the appliance	15
Installation and connection	10	Cleaning the condensation channel and drainage hole	16
Scope of delivery.....	10	Removing the fittings.....	16
Criteria for the installation location.....	11	Troubleshooting	17
Installing the appliance	11	Malfunctions	17
Preparing the appliance for the first time.....	11	Conducting an appliance self-test.....	19
Connecting the appliance to the electricity supply.....	12	Storage and disposal	19
Familiarising yourself with your appliance	12	Taking the appliance out of operation	19
Appliance	12	Disposing of old appliance	19
Control panel.....	12	Customer Service	20
Features	12	Product number (E-Nr.) and production number (FD)	20
Shelf.....	12	Technical data	20
Fruit and vegetable container	12		
Door rack.....	13		
Accessories.....	13		
Basic operation	13		
Switching on the appliance	13		
Operating tips.....	13		
Switching off the appliance	13		
Setting the temperature.....	13		



Safety

Observe the following safety instructions.

General information

- Read this instruction manual carefully.
- Keep the instruction manual and the product information safe for future reference or for the next owner.
- Do not connect the appliance if it has been damaged in transit.

Intended use

This appliance is only intended to be fully fitted in a kitchen.

Only use this appliance:

- For chilling food.
- In private households and in enclosed spaces in a domestic environment.
- Up to an altitude of max. 2000 m above sea level.

Restriction on user group

This appliance may be used by children aged 8 or over and by people who have reduced physical, sensory or mental abilities or inadequate experience and/or knowledge, provided that they are supervised or have been instructed on how to use the appliance safely and have understood the resulting dangers.

Children must not play with the appliance.

Cleaning and user maintenance must not be performed by children unless they are being supervised.

Children above the age of three years old and younger than eight years old may load and unload the the fridge-freezer.

Safe transport



WARNING – Risk of injury!

The high weight of the appliance may result in injury when lifted.

- ▶ Do not lift the appliance on your own.

Safe installation

WARNING – Risk of electric shock!

- Improper installation is dangerous.
 - ▶ Connect and operate the appliance only in accordance with the specifications on the rating plate.
 - ▶ Connect the appliance to a power supply with alternating current only via a properly installed socket with earthing.
 - ▶ The protective conductor system of the domestic electrical installation must be properly installed.
 - ▶ Never equip the appliance with an external switching device, e.g. a timer or remote control.
 - ▶ When the appliance is installed, the mains plug of the power cord must be freely accessible. If free access is not possible, an all-pole isolating switch must be installed in the permanent electrical installation according to the installation regulations.
 - ▶ When installing the appliance, check that the power cable is not trapped or damaged.
- If the insulation of the power cord is damaged, this is dangerous.
 - ▶ Never let the power cord come into contact with heat sources.

WARNING – Risk of explosion!

If the appliance's ventilation openings are sealed, a leak in the refrigeration circuit may result in a flammable mixture of gas and air.

- ▶ Keep ventilation openings, in the appliance enclosure or in the built-in structure, clear of obstruction.

WARNING – Risk of fire!

- It is dangerous to use an extended power cord and non-approved adapters.
 - ▶ Do not use extension cables or multiple socket strips.
 - ▶ If the power cord is too short, contact Customer Service.
 - ▶ Only use adapters approved by the manufacturer.

- Portable multiple socket strips or portable power supply units may overheat and cause a fire.
 - ▶ Do not place portable multiple socket strips or power supply units on the back of the appliance.

Safe use

WARNING – Risk of electric shock!

An ingress of moisture can cause an electric shock.

- ▶ Only use the appliance in enclosed spaces.
- ▶ Never expose the appliance to intense heat or humidity.
- ▶ Do not use steam- or high-pressure cleaners to clean the appliance.

WARNING – Risk of suffocation!

- Children may put packaging material over their heads or wrap themselves up in it and suffocate.
 - ▶ Keep packaging material away from children.
 - ▶ Do not let children play with packaging material.
- Children may breathe in or swallow small parts, causing them to suffocate.
 - ▶ Keep small parts away from children.
 - ▶ Do not let children play with small parts.

WARNING – Risk of explosion!

- If the cooling circuit is damaged, flammable refrigerant may escape and explode.
 - ▶ To accelerate the defrosting process, do not use any other mechanical devices or means other than those recommended by the manufacturer.
 - ▶ If food is stuck to the freezer compartment, loosen it with a blunt implement such as the handle of a wooden spoon.
- Products which contain flammable propellants and explosive substances may explode, e.g. spray cans.
 - ▶ Do not store products which contain flammable propellants (e.g. spray cans) or explosive substances in the appliance.

⚠ WARNING – Risk of fire!

Electrical devices within the appliance may cause a fire, e.g. heaters or electric ice makers.

- ▶ Do not operate electrical devices within the appliance.

⚠ WARNING – Risk of injury!

Injury to the eyes caused by escaping flammable refrigerant and hazardous gases.

- ▶ Do not damage the tubes of the refrigerant circuit or the insulation.

⚠ CAUTION – Risk of harm to health!

- To prevent food from being contaminated, you must observe the following instructions.
 - ▶ If the door is open for an extended period of time, this may lead to a considerable temperature increase in the compartments of the appliance.
 - ▶ Regularly clean the surfaces that may come into contact with food and accessible drain systems.
 - ▶ Store raw meat and fish in suitable containers in the refrigerator so that they do not touch or drip on other food.
 - ▶ If the fridge/freezer is empty for an extended period of time, switch off the appliance, defrost it, clean it and leave the door open to prevent the formation of mould.
- Metal or metal-style parts in the appliance may contain aluminium. If acidic food comes into contact with aluminium in the appliance, aluminium foil ions may pass into the food.
 - ▶ Do not consume soiled food.

Damaged appliance

⚠ WARNING – Risk of electric shock!

- If the appliance or the power cord is damaged, this is dangerous.
 - ▶ Never operate a damaged appliance.
 - ▶ Never pull on the power cord to unplug the appliance. Always unplug the appliance at the mains.

- ▶ If the appliance or the power cord is damaged, immediately unplug the power cord or switch off the fuse in the fuse box.
- ▶ "Call customer services." → *Page 20*
- Incorrect repairs are dangerous.
 - ▶ Repairs to the appliance should only be carried out by trained specialist staff.
 - ▶ Only use genuine spare parts when repairing the appliance.
 - ▶ If the power cord of this appliance is damaged, it must be replaced by the manufacturer, the manufacturer's Customer Service or a similarly qualified person in order to prevent any risk.

⚠ WARNING – Risk of fire!



If the tubes are damaged, flammable refrigerant and harmful gases may escape and ignite.

- ▶ Keep naked flames and ignition sources away from the appliance.
- ▶ Ventilate the room.
- ▶ "Switch off the appliance." → *Page 13*
- ▶ Unplug the appliance from the mains or switch off the circuit breaker in the fuse box.
- ▶ "Call after-sales service." → *Page 20*

Preventing material damage

ATTENTION!

- Using the base, runners or appliance doors as a seat surface or climbing surface may damage the appliance.
 - ▶ Do not stand or support yourself on the base, runners or doors.
- Contamination with oil or fat may cause plastic parts and door seals to become porous.
 - ▶ Keep plastic parts and door seals free of oil and grease.
- Metal or metal-style parts in the appliance may contain aluminium. Aluminium reacts when it comes into contact with acidic foods.
 - ▶ Do not store unpackaged food in the appliance.

Environmental protection and saving energy

Disposing of packaging

The packaging materials are environmentally compatible and can be recycled.

- ▶ Sort the individual components by type and dispose of them separately.

Saving energy

If you follow these instructions, your appliance will use less power.

Selecting the installation location

- Keep the appliance out of direct sunlight.

- Install the appliance as far away as possible from heating elements, cookers and other heat sources:
 - Maintain a 30 mm clearance to electric or gas cookers.
 - Maintain a 300 mm clearance to oil or solid-fuel cookers.
- Use a niche depth of 560 mm.
- Never cover or block the exterior ventilation grilles.

Saving energy during use

Note: The arrangement of the fittings does not affect the energy consumption of the appliance.

- Open the appliance only briefly and then close it carefully.
- Never cover or block the interior ventilation openings or the exterior ventilation grilles.
- Transport purchased food in a cool bag and place in the appliance quickly.
- Allow warm food and drinks to cool down before storing them.
- Thaw frozen food in the refrigerator compartment to utilise the low temperature of the food.
- Always leave some space between the food and to the back panel.

Installation and connection

Scope of delivery

After unpacking all parts, check for any transport damage and for completeness of delivery.

If you have any complaints, contact your dealer or our "after-sales service" → *Page 20*.

The delivery consists of the following:

- Built-in appliance

- Equipment and accessories¹
- Installation material
- Installation instructions
- User manual
- Customer service directory
- Warranty enclosure²
- Energy label
- Information on energy consumption and noises

Criteria for the installation location

WARNING **Risk of explosion!**

If the appliance is in a space that is too small, a leak in the refrigeration circuit may result in a flammable mixture of gas and air.

- ▶ Only install the appliance in a space with a volume of at least 1 m³ per 8 g refrigerant. The volume of refrigerant is indicated on the rating plate. → Fig. **1**/**3**

The weight of the appliance ex works may be up to 70 kg depending on the model.

The subfloor must be sufficiently stable to bear the weight of the appliance.

Permitted room temperature

The permitted room temperature depends on the appliance's climate class.

The climate class can be found on the rating plate. → Fig. **1**/**3**

Climate class	Permitted room temperature
SN	10 °C to 32 °C
N	16 °C to 32 °C

Climate class	Permitted room temperature
ST	16 °C to 38 °C
T	16 °C to 43 °C

The appliance is fully functional within the permitted room temperature.

If an appliance with climate class SN is operated at colder room temperatures, the appliance will not be damaged up to a room temperature of 5 °C.

Niche dimensions

Observe the niche dimensions if you install your appliance in the niche. If this is not the case, problems may occur when installing the appliance.

Niche depth

Install the appliance in the recommended niche depth of 560 mm. If the niche depth is smaller, the energy consumption increases slightly. The niche depth must be a minimum 550 mm.

Niche width

An inside niche width of at least 560 mm is required for the appliance.

Installing the appliance

- ▶ Install the appliance in accordance with the enclosed installation instructions.

Preparing the appliance for the first time

1. Remove the informative material.
2. Remove the protective foil and transit bolts, e.g. remove the adhesive strips and carton.

¹ Depending on the appliance specifications

² Not in all countries

en Familiarising yourself with your appliance

3. "Clean the appliance for the first time." → Page 15

Connecting the appliance to the electricity supply

1. Insert the mains plug of the appliance's power cable in a socket nearby.

The connection data of the appliance can be found on the rating plate. → Fig. 1/3

2. Check the mains plug is inserted properly.
- ✓ The appliance is now ready for use.

Familiarising yourself with your appliance

Appliance

You can find an overview of the parts of your appliance here.

Note: Deviations between your appliance and the diagrams may differ with regard to their features and size.

→ Fig. 1

1	"Control panel" → Page 12
2	"Fruit and vegetable container" → Page 12
3	"Rating plate" → Page 20
4	"Door storage compartment for large bottles" → Page 13

Control panel

You can use the control panel to configure all functions of your appliance and to obtain information about the operating status.

→ Fig. 2

1	°C sets the temperature of the refrigerator compartment.
2	super lights up when Super cooling is switched on.
3	Displays the set temperature for the refrigerator compartment in °C.
4	⓪ switches the appliance on or off.

Features

The features of your appliance depend on the model.

Shelf

To vary the shelf as required, you can remove the shelf and re-insert it elsewhere.

→ "Removing the shelf", Page 16

Fruit and vegetable container

Store fresh fruit and vegetables in their packaging in the fruit and vegetable container.

Cover any chopped fruit and vegetables, or store in air-tight packaging. Condensation may form in the fruit and vegetable container depending on the food and quantity stored.

Remove the condensation with a dry cloth.

To ensure that the quality and aroma are retained, store fruit and vegetables that are sensitive to cold outside of the appliance at temperatures of approx. 8 °C to 12 °C, e.g. pineapple, bananas, citrus fruits, cucumbers, courgettes, peppers, tomatoes and potatoes.

Door rack

To adjust the door racks as required, you can remove the door rack and re-insert elsewhere.

→ "Removing door rack", Page 16

Accessories

Use original accessories. These have been made especially for your appliance.

The accessories for your appliance depend on the model.

Egg tray

Store eggs safely on the egg tray.

Basic operation

Switching on the appliance

1. Press ①.
- ✓ The appliance begins to cool.
2. "Set the required temperature."
→ Page 13

Operating tips

- Once you have switched on the appliance, the set temperature is only reached after several hours. Do not put any food in the appliance until the set temperature has been reached.
- When you close the door, a vacuum may be created. The door is then difficult to open again. Wait a moment until the vacuum is offset.

Switching off the appliance

- ▶ Press ①.

Setting the temperature

Setting the refrigerator compartment temperature

- ▶ Press °C repeatedly until the temperature display shows the required temperature.

The recommended temperature in the refrigerator compartment is 4 °C.

→ ""OK" sticker", Page 14

Additional functions

Super cooling

With Super cooling, the refrigerator compartment cools as cold as possible.

Switch on Super cooling before placing large quantities of food.

Note: When Super cooling is switched on, increased noise may occur.

Switching on Super cooling

- ▶ Press °C repeatedly until **super** lights up.

Note: After approx. 15 hours, the appliance switches to normal operation.

Switching off Super cooling

- ▶ Press °C.

Refrigerator compartment

You can keep meat, sausage, fish, dairy products, eggs, prepared meals and pastries in the refrigerator compartment.

The temperature can be set from 2 °C to 8 °C.

en Defrosting

The refrigerator compartment can also be used to store highly perishable foods in the short to medium term. The lower the selected temperature, the longer the food remains fresh.

Tips for storing food in the refrigerator compartment

- Only store food when fresh and undamaged.
- Store food covered or in air-tight packaging.
- Allow hot food and drinks to cool down first before placing in the appliance.
- Observe the best-before date or use-by date specified by the manufacturer.

Chill zones in the refrigerator compartment

The air circulation in the refrigerator compartment creates different chill zones.

Coldest zone

The coldest zone is between the arrow stamped on the side and the shelf underneath.

Tip: Store highly perishable food such as fish, sausages and meat in the coldest zone.

Warmest zone

The warmest zone is at the very top of the door.

Tip: Store food that does not spoil easily in the warmest zone, e.g. hard cheese and butter. Cheese can then continue to release its aroma and the butter will still be easy to spread.

"OK" sticker

The "OK" sticker lets you check whether the refrigerator compartment reaches the safe temperature ranges of +4 °C or colder recommended for food.

The "OK" sticker is not included with all models.

If the sticker does not indicate "OK", gradually reduce the temperature.

→ *"Setting the refrigerator compartment temperature", Page 13*

Once the appliance is switched on, it may take up to 12 hours until the set temperature is reached.



Correct setting

Defrosting

Defrosting in the refrigerator compartment

When the appliance is operating, condensation droplets or frost form on the rear panel of the refrigerator compartment due to functional reasons. The back panel in the refrigerator compartment defrosts automatically.

Condensation runs through the condensation channel into the drainage hole to the evaporation pan and does not have to be wiped away.

To ensure that the condensation can drain and odours do not form, observe the following information:

→ *"Cleaning the condensation channel and drainage hole", Page 16.*

Cleaning and servicing

To keep your appliance working efficiently for a long time, it is important to clean and maintain it carefully. Customer Service must clean inaccessible points. Cleaning by customer service can give rise to costs.

Care instructions for stainless steel surfaces

When taking care of and cleaning stainless steel surfaces, use only cleaning cloths and cleaning agents suitable for stainless steel.

Tips

- To prevent visible scratches, wipe the stainless steel surface in the direction of the grain.
- Suitable cleaning agents and cleaning cloths are available from our customer service, your dealer or on our website.

Preparing the appliance for cleaning

1. "Switch off the appliance."
→ *Page 13*
2. Disconnect the appliance from the power supply.
Unplug the appliance from the mains or switch off the circuit breaker in the fuse box.
3. Take out all of the food and store it in a cool place.
Place ice packs (if available) onto the food.
4. If there is a layer of hoarfrost, allow this to defrost.
5. "Remove all fittings and accessories from the appliance."
→ *Page 16*

Cleaning the appliance

WARNING

Risk of electric shock!

- An ingress of moisture can cause an electric shock.
 - ▶ Do not use steam- or high-pressure cleaners to clean the appliance.
- Liquid in the lighting or in the controls can be dangerous.
 - ▶ The rinsing water must not drip into the lighting or controls.

ATTENTION!

- Unsuitable cleaning products may damage the surfaces of the appliance.
 - ▶ Do not use hard scouring pads or cleaning sponges.
 - ▶ Do not use harsh or abrasive detergents.
 - ▶ Do not use cleaning products with a high alcohol content.
 - ▶ Do not use stainless-steel cleaning agents on the outside of the appliance.
 - If liquid gets into the drainage hole, the evaporation pan may overflow.
 - ▶ The rinsing water must not get into the drainage hole.
 - If you clean fittings and accessories in the dishwasher, this may cause them to become deformed or discoloured.
 - ▶ Never clean fittings and accessory in the dishwasher.
1. "Prepare the appliance for cleaning." → *Page 15*
 2. Clean the appliance, the fittings, the accessories and the door seals with a dish cloth, lukewarm water and a little pH-neutral washing-up liquid.
 3. Dry thoroughly with a soft, dry cloth.

en Cleaning and servicing

4. Insert the fittings.
5. Electrically connect the appliance.
6. "Switch on the appliance."
→ Page 13
7. Putting the food into the appliance.

Cleaning the condensation channel and drainage hole

Regularly clean the condensation channel and drainage hole to ensure that the condensation can drain.

- ▶ Carefully clean the condensation channel and the drainage hole, e.g. using a moistened cotton bud.
→ Fig. **3**

Removing the fittings

If you want to clean the fittings thoroughly, remove these from your appliance.

Removing the shelf

- ▶ Pull out and remove the shelf.
→ Fig. **4**

Removing door rack

- ▶ Lift the door rack and remove it.
→ Fig. **5**

Removing the fruit and vegetable container

1. Pull out the fruit and vegetable container as far as it will go.
2. Press the latch on the pull-out rail downwards ① and remove the fruit and vegetable container ②.
→ Fig. **6**

Troubleshooting

You can rectify minor faults on your appliance yourself. Read the troubleshooting information before contacting after-sales service. This will avoid unnecessary costs.

⚠ WARNING

Risk of electric shock!

Incorrect repairs are dangerous.

- ▶ Repairs to the appliance should only be carried out by trained specialist staff.
- ▶ Only use genuine spare parts when repairing the appliance.
- ▶ If the power cord of this appliance is damaged, it must be replaced by the manufacturer, the manufacturer's Customer Service or a similarly qualified person in order to prevent any risk.

Malfunctions

Fault	Cause	Troubleshooting
The appliance is not cooling, the displays and lighting light up.	Showroom mode is switched on.	<ul style="list-style-type: none"> ▶ "Carry out the appliance self-test." → <i>Page 19</i> ✓ Once the appliance self-test has ended, the appliance switches to normal operation.
The LED lighting does not work.	Different causes are possible.	<ul style="list-style-type: none"> ▶ Call customer service. The customer service number can be found in the enclosed customer service directory.
The temperature differs greatly from the setting.	Different causes are possible.	<ol style="list-style-type: none"> 1. "Switch off the appliance." → <i>Page 13</i> 2. "Switch the appliance back on after five minutes." → <i>Page 13</i> <ul style="list-style-type: none"> - If the temperature is too warm, check the temperature again after a couple of hours. - If the temperature is too cold, check the temperature again on the following day.
The base of the refrigerator compartment is wet.	The condensation channel or drainage hole are blocked.	<ul style="list-style-type: none"> ▶ "Clean the condensation channel and the drainage hole." → <i>Page 16</i>

en Troubleshooting

Fault	Cause	Troubleshooting
The appliance hums, bubbles, buzzes, gargles or clicks.	Not a fault. A motor is running, e.g. refrigerating unit, fan. Refrigerant flows through the pipes. The motor, switches or solenoid valves are switching on or off.	No action required.
The appliance makes noises.	Fittings wobble or stick.	▶ Check the removable fittings and, if required, replace these.
	Bottles or containers are touching.	▶ Move the bottles or containers away from each other.

Conducting an appliance self-test

1. "Switch off the appliance."
→ Page 13
2. "Switch the appliance back on after approx. five minutes."
→ Page 13
3. Within 10 seconds of switching on, press and hold °C for three to five seconds until 2 °C lights up in the temperature display.
 - ✓ The appliance self-test starts when the temperature displays light up in succession.
 - ✓ If, at the end of the appliance self-test, the temperature display shows the set temperature, your appliance is OK. The appliance switches to normal operation.
 - ✓ If, at the end of the appliance self-test, **super** flashes for 10 seconds, inform the after-sales service.

Storage and disposal

You can find out here how to prepare your appliance for storage. You will also find out how to dispose of old appliances.

Taking the appliance out of operation

1. "Switch off the appliance."
→ Page 13
2. Disconnect the appliance from the power supply.
Unplug the appliance from the mains or switch off the circuit breaker in the fuse box.
3. Remove all of the food.
4. "Defrost the appliance." → Page 14
5. "Clean the appliance." → Page 15

6. To guarantee the ventilation inside the appliance, leave the appliance open.

Disposing of old appliance

Valuable raw materials can be re-used by recycling.

WARNING **Risk of harm to health!**

Children can lock themselves in the appliance, thereby putting their lives at risk.

- ▶ Leave shelves and containers inside the appliance to prevent children from climbing in.
- ▶ Keep children away from the redundant appliance.

WARNING **Risk of fire!**

If the tubes are damaged, flammable refrigerant and harmful gases may escape and ignite.

- ▶ Do not damage the tubes of the refrigerant circuit or the insulation.

1. Unplug the appliance from the mains.
2. Cut through the power cord.
3. Dispose of the appliance in an environmentally friendly manner.

Information about current disposal methods are available from your specialist dealer or local authority.



This appliance is labelled in accordance with European Directive 2012/19/EU concerning used electrical and electronic appliances (waste electrical and electronic equipment - WEEE). The guideline determines the framework for the return and recycling of used appliances as applicable throughout the EU.

Customer Service

If you have any queries, are unable to rectify faults on the appliance yourself or if your appliance needs to be repaired, contact Customer Service. Function-relevant genuine spare parts according to the corresponding Eco-design Order can be obtained from Customer Service for a period of at least 10 years from the date on which your appliance was placed on the market within the European Economic Area.

Note: Under the terms of the manufacturer's warranty applicable to the location, the use of Customer Service is free of charge. The minimum duration of the warranty (manufacturer's warranty for private consumers) in the European Economic Area is 2 years according to the terms of warranty applicable to the location. The terms of warranty do not affect other rights or claims held by yourself under local legislation.

Detailed information on the warranty period and terms of warranty in your country is available from our after-sales service, your retailer or on our website.

If you contact Customer Service, you will require the product number (E-Nr.) and the production number (FD) of your appliance.

The contact details for Customer Service can be found in the enclosed Customer Service directory or on our website.

Product number (E-Nr.) and production number (FD)

You can find the product number (E-Nr.) and the production number (FD) on the appliance's rating plate.

→ Fig. 11/3

Make a note of your appliance's details and the Customer Service telephone number to find them again quickly.

Technical data

Refrigerant, cubic capacity and further technical specifications can be found on the rating plate.

→ Fig. 11/3

You can find more information about your model online at <https://eprel.ec.europa.eu/>¹. This web address is linked to the official EU EPREL product database. Please then follow the instructions on searching for models. The model identifier is made up of the characters before the slash in the product number (E-Nr.) on the rating plate. Alternatively, you can also find the model identifier in the first line of the EU energy label.

¹ Only applies to countries in the European Economic Area



A series of horizontal lines for writing, starting from the top right of the pencil icon and extending across the width of the page. The lines are evenly spaced and cover the majority of the page area.

BSH Hausgeräte GmbH

Carl-Wery-Straße 34

81739 München

GERMANY

www.siemens-home.bsh-group.com

Manufactured by BSH Hausgeräte GmbH under the trademark licence of Siemens AG



9001595512

(010519)

en