



**SIEMENS**

## Fridge-freezer

---

K..IS..

en User manual



Register your product on My Siemens and discover exclusive services and offers.  
[siemens-home.bsh-group.com/welcome](https://siemens-home.bsh-group.com/welcome)

The future moving in.

Siemens Home Appliances

## Table of contents

<b>1 Safety</b> .....	<b>4</b>	<b>7 Basic operation</b> .....	<b>16</b>
1.1 General information.....	4	7.1 Switching on the appliance .....	16
1.2 Intended use.....	4	7.2 Operating tips.....	16
1.3 Restriction on user group.....	4	7.3 Switching off the appliance .....	16
1.4 Safe transport.....	4	7.4 Setting the temperature.....	16
1.5 Safe installation .....	5	<b>8 Additional functions</b> .....	<b>16</b>
1.6 Safe use .....	6	8.1 Super cooling .....	16
1.7 Damaged appliance .....	8	8.2 Automatic Super freezing.....	17
<b>2 Preventing material damage</b> .....	<b>9</b>	8.3 Manual Super freezing .....	17
<b>3 Environmental protection and saving energy</b> .....	<b>9</b>	8.4 Holiday mode .....	17
3.1 Disposing of packaging .....	9	<b>9 Alarm</b> .....	<b>18</b>
3.2 Saving energy.....	9	9.1 Door alarm .....	18
<b>4 Installation and connection</b> .....	<b>10</b>	9.2 Temperature alarm.....	18
4.1 Scope of delivery.....	10	<b>10 Refrigerator compartment</b> .....	<b>18</b>
4.2 Criteria for the installation location.....	10	10.1 Tips for storing food in the refrigerator compartment .....	18
4.3 Installing the appliance .....	11	10.2 Chill zones in the refrigerator compartment.....	19
4.4 Preparing the appliance for the first time.....	11	10.3 "OK" sticker .....	19
4.5 Connecting the appliance to the electricity supply.....	11	<b>11 Freezer compartment</b> .....	<b>19</b>
<b>5 Familiarising yourself with your appliance</b> .....	<b>12</b>	11.1 Freezing capacity .....	19
5.1 Appliance .....	12	11.2 Fully utilising the freezer compartment volume .....	20
5.2 Control panel.....	13	11.3 Tips for storing food in the freezer compartment .....	20
<b>6 Features</b> .....	<b>14</b>	11.4 Freezing smaller amounts of food quickly.....	20
6.1 Shelf.....	14	11.5 Tips for freezing fresh food ...	20
6.2 Variable shelf.....	14	11.6 Shelf life of frozen food at -18 °C.....	20
6.3 Extendable shelf .....	14	11.7 Defrosting methods for frozen food .....	21
6.4 Fruit and vegetable container with humidity control .....	14	<b>12 Defrosting</b> .....	<b>21</b>
6.5 Flat frozen food container .....	15	12.1 Defrosting in the refrigerator compartment.....	21
6.6 Butter and cheese compartment.....	15	12.2 Defrosting in the freezer compartment .....	21
6.7 Door racks.....	15		
6.8 Accessories.....	15		

<b>13 Cleaning and servicing .....</b>	<b>22</b>
13.1 Preparing the appliance for cleaning .....	22
13.2 Cleaning the appliance .....	22
13.3 Cleaning the condensation channel and drainage hole ....	23
13.4 Removing the fittings.....	23
<b>14 Troubleshooting.....</b>	<b>25</b>
<b>15 Storage and disposal .....</b>	<b>28</b>
15.1 Switching off the appliance ....	28
15.2 Disposing of old appliance ....	28
<b>16 Customer Service.....</b>	<b>29</b>
16.1 Product number (E-Nr.) and production number (FD).....	29
<b>17 Technical data .....</b>	<b>29</b>



## 1 Safety

---

Observe the following safety instructions.

### 1.1 General information

- Read this instruction manual carefully.
- Keep the instruction manual and the product information safe for future reference or for the next owner.
- Do not connect the appliance if it has been damaged in transit.

### 1.2 Intended use

This appliance is only intended to be fully fitted in a kitchen.

Only use this appliance:

- for chilling and freezing food, and for dispensing ice.
- In private households and in enclosed spaces in a domestic environment.
- Up to an altitude of max. 2000 m above sea level.

### 1.3 Restriction on user group

This appliance may be used by children aged 8 or over and by people who have reduced physical, sensory or mental abilities or inadequate experience and/or knowledge, provided that they are supervised or have been instructed on how to use the appliance safely and have understood the resulting dangers.

Children must not play with the appliance.

Cleaning and user maintenance must not be performed by children unless they are being supervised.

Children above the age of three years old and younger than eight years old may load and unload the the fridge-freezer.

### 1.4 Safe transport

#### **WARNING – Risk of injury!**

The high weight of the appliance may result in injury when lifted.

- ▶ Do not lift the appliance on your own.

## 1.5 Safe installation

### **WARNING – Risk of electric shock!**

Improper installation is dangerous.

- ▶ Connect and operate the appliance only in accordance with the specifications on the rating plate.
- ▶ Connect the appliance to a power supply with alternating current only via a properly installed socket with earthing.
- ▶ The protective conductor system of the domestic electrical installation must be properly installed.
- ▶ Never equip the appliance with an external switching device, e.g. a timer or remote control.
- ▶ When the appliance is installed, the mains plug of the power cord must be freely accessible. If free access is not possible, an all-pole isolating switch must be installed in the permanent electrical installation according to the installation regulations.
- ▶ When installing the appliance, check that the power cable is not trapped or damaged.

If the insulation of the power cord is damaged, this is dangerous.

- ▶ Never let the power cord come into contact with heat sources.

### **WARNING – Risk of explosion!**

If the appliance's ventilation openings are sealed, a leak in the refrigeration circuit may result in a flammable mixture of gas and air.

- ▶ Keep ventilation openings, in the appliance enclosure or in the built-in structure, clear of obstruction.

### **WARNING – Risk of fire!**

It is dangerous to use an extended power cord and non-approved adapters.

- ▶ Do not use extension cables or multiple socket strips.
- ▶ If the power cord is too short, contact Customer Service.
- ▶ Only use adapters approved by the manufacturer.

Portable multiple socket strips or portable power supply units may overheat and cause a fire.

- ▶ Do not place portable multiple socket strips or power supply units on the back of the appliance.

## 1.6 Safe use

### **⚠ WARNING – Risk of electric shock!**

An ingress of moisture can cause an electric shock.

- ▶ Only use the appliance in enclosed spaces.
- ▶ Never expose the appliance to intense heat or humidity.
- ▶ Do not use steam- or high-pressure cleaners to clean the appliance.

### **⚠ WARNING – Risk of suffocation!**

Children may put packaging material over their heads or wrap themselves up in it and suffocate.

- ▶ Keep packaging material away from children.
- ▶ Do not let children play with packaging material.

Children may breathe in or swallow small parts, causing them to suffocate.

- ▶ Keep small parts away from children.
- ▶ Do not let children play with small parts.

### **⚠ WARNING – Risk of explosion!**

Mechanical devices or other devices may damage the refrigeration circuit; flammable refrigerant may escape and explode.

- ▶ To accelerate the defrosting process, do not use any other mechanical devices or devices other than those recommended by the manufacturer.

Products which contain flammable propellants and explosive substances may explode, e.g. spray cans.

- ▶ Do not store products which contain flammable propellants (e.g. spray cans) or explosive substances in the appliance.

### **⚠ WARNING – Risk of fire!**

Electrical devices within the appliance may cause a fire, e.g. heaters or electric ice makers.

- ▶ Do not operate electrical devices within the appliance.

**⚠ WARNING – Risk of injury!**

Containers that contain carbonated drinks may burst.

- ▶ Do not store containers that contain carbonated drinks in the freezer compartment.

Injury to the eyes caused by escaping flammable refrigerant and hazardous gases.

- ▶ Do not damage the tubes of the refrigerant circuit or the insulation.

**⚠ WARNING – Risk of cold burns!**

Contact with frozen food and cold surfaces may cause burns by refrigeration.

- ▶ Never put frozen food straight from the freezer compartment into your mouth.
- ▶ Avoid prolonged contact of the skin with frozen food, ice and surfaces in the freezer compartment.

**⚠ CAUTION – Risk of harm to health!**

To prevent food from being contaminated, you must observe the following instructions.

- ▶ If the door is open for an extended period of time, this may lead to a considerable temperature increase in the compartments of the appliance.
- ▶ Regularly clean the surfaces that may come into contact with food and accessible drain systems.
- ▶ Store raw meat and fish in suitable containers in the refrigerator so that they do not touch or drip on other food.
- ▶ If the fridge/freezer is empty for an extended period of time, switch off the appliance, defrost it, clean it and leave the door open to prevent the formation of mould.

Metal or metal-style parts in the appliance may contain aluminium. If acidic food comes into contact with aluminium in the appliance, aluminium foil ions may pass into the food.

- ▶ Do not consume soiled food.

## 1.7 Damaged appliance

### **WARNING – Risk of electric shock!**

If the appliance or the power cord is damaged, this is dangerous.

- ▶ Never operate a damaged appliance.
- ▶ Never pull on the power cord to unplug the appliance. Always unplug the appliance at the mains.
- ▶ If the appliance or the power cord is damaged, immediately unplug the power cord or switch off the fuse in the fuse box.
- ▶ Call customer services. → *Page 29*

Incorrect repairs are dangerous.

- ▶ Repairs to the appliance should only be carried out by trained specialist staff.
- ▶ Only use genuine spare parts when repairing the appliance.
- ▶ If the power cord of this appliance is damaged, it must be replaced by the manufacturer, the manufacturer's Customer Service or a similarly qualified person in order to prevent any risk.

### **WARNING – Risk of fire!**



If the tubes are damaged, flammable refrigerant and harmful gases may escape and ignite.

- ▶ Keep naked flames and ignition sources away from the appliance.
- ▶ Ventilate the room.
- ▶ Switch off the appliance. → *Page 16*
- ▶ Unplug the appliance from the mains or switch off the circuit breaker in the fuse box.
- ▶ Call after-sales service. → *Page 29*

---

## 2 Preventing material damage

### ATTENTION!

Using the base, runners or appliance doors as a seat surface or climbing surface may damage the appliance.

- ▶ Do not stand or support yourself on the base, runners or doors.

Contamination with oil or fat may cause plastic parts and door seals to become porous.

- ▶ Keep plastic parts and door seals free of oil and grease.

Metal or metal-style parts in the appliance may contain aluminium. Aluminium reacts when it comes into contact with acidic foods.

- ▶ Do not store unpackaged food in the appliance.

---

## 3 Environmental protection and saving energy

### 3.1 Disposing of packaging

The packaging materials are environmentally compatible and can be recycled.

- ▶ Sort the individual components by type and dispose of them separately.

### 3.2 Saving energy

If you follow these instructions, your appliance will use less power.

#### Selecting the installation location

- Keep the appliance out of direct sunlight.
- Install the appliance as far away as possible from heating elements, cookers and other heat sources:

- Maintain a 30 mm clearance to electric or gas cookers.
- Maintain a 300 mm clearance to oil or solid-fuel cookers.
- Use a niche depth of 560 mm.
- Never cover or block the exterior ventilation grilles.

#### Saving energy during use

**Note:** The arrangement of the fittings does not affect the energy consumption of the appliance.

- Open the appliance only briefly.
- Never cover or block the interior ventilation openings or the exterior ventilation grilles.
- Transport purchased food in a cool bag and place in the appliance quickly.
- Allow warm food and drinks to cool down before storing them.
- Thaw frozen food in the refrigerator compartment to utilise the low temperature of the food.
- Always leave some space between the food and to the back panel.
- Pack the food airtight.
- Defrost the freezer compartment regularly.
- Open the freezer compartment door only briefly and then close it properly.

## 4 Installation and connection

You can find out where and how best to install your appliance here. You will also learn how to connect your appliance to the power supply.

### 4.1 Scope of delivery

After unpacking all parts, check for any transport damage and for completeness of delivery.

If you have any complaints, contact your dealer or our after-sales service → Page 29.

The delivery consists of the following:

- Built-in appliance
- Equipment and accessories<sup>1</sup>
- Installation material
- Installation instructions
- User manual
- Customer service directory
- Warranty enclosure<sup>2</sup>
- Energy label
- Information on energy consumption and noises

### 4.2 Criteria for the installation location

#### WARNING

##### Risk of explosion!

If the appliance is in a space that is too small, a leak in the refrigeration circuit may result in a flammable mixture of gas and air.

- ▶ Only install the appliance in a space with a volume of at least 1 m<sup>3</sup> per 8 g refrigerant. The

volume of refrigerant is indicated on the rating plate. → "Appliance", Fig. 1/5, Page 13

The weight of the appliance ex works may be up to 75 kg depending on the model.

The subfloor must be sufficiently stable to bear the weight of the appliance.

#### Permitted room temperature

The permitted room temperature depends on the appliance's climate class.

The climate class can be found on the rating plate. → "Appliance", Fig.

1/5, Page 13

Climate class	Permitted room temperature
SN	10 °C to 32 °C
N	16 °C to 32 °C
ST	16 °C to 38 °C
T	16 °C to 43 °C

The appliance is fully functional within the permitted room temperature.

If an appliance with climate class SN is operated at colder room temperatures, the appliance will not be damaged up to a room temperature of 5 °C.

#### Niche dimensions

Observe the niche dimensions if you install your appliance in the niche. If this is not the case, problems may occur when installing the appliance.

#### Niche depth

Install the appliance in the recommended niche depth of 560 mm.

<sup>1</sup> Depending on the appliance specifications

<sup>2</sup> Not in all countries

If the niche depth is smaller, the energy consumption increases slightly. The niche depth must be a minimum 550 mm.

### **Niche width**

An inside niche width of at least 560 mm is required for the appliance.

### **Side-by-side installation**

If you want to install two appliances side by side, you must maintain a distance of at least 150 mm between the appliances.

## **4.3 Installing the appliance**

- ▶ Install the appliance in accordance with the enclosed installation instructions.

## **4.4 Preparing the appliance for the first time**

1. Remove the informative material.
2. Remove the protective foil and transit bolts, e.g. remove the adhesive strips and carton.
3. Clean the appliance for the first time. → *Page 22*

## **4.5 Connecting the appliance to the electricity supply**

1. Insert the mains plug of the appliance's power cable in a socket nearby.  
The connection data of the appliance can be found on the rating plate. → "*Appliance*", Fig. **1**/**5**, *Page 13*
  2. Check the mains plug is inserted properly.
- ✓ The appliance is now ready for use.

## 5 Familiarising yourself with your appliance

### 5.1 Appliance

You can find an overview of the parts of your appliance here.

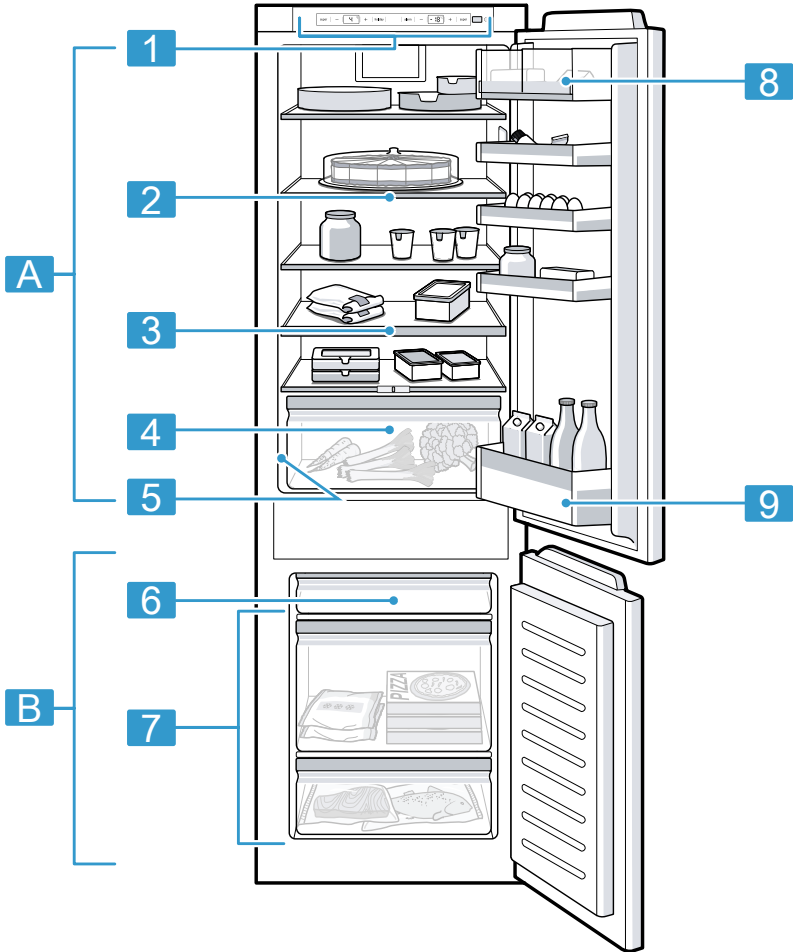

- 1** Controls
- A** Refrigerator compartment
- B** Freezer compartment

- 2** Variable shelf → Page 14
- 3** Extendable shelf → Page 14

- 4** Fruit and vegetable container with humidity control  
→ *Page 14*

---

- 5** Rating plate

---

- 6** Flat frozen food container  
→ *Page 15*

---

- 7** Frozen food container

- 8** Butter and cheese compartment → *Page 15*

---

- 9** Door storage compartment for large bottles

**Note:** Deviations between your appliance and the diagrams may differ with regard to their features and size.

## 5.2 Control panel

You can use the control panel to configure all functions of your appliance and to obtain information about the operating status.

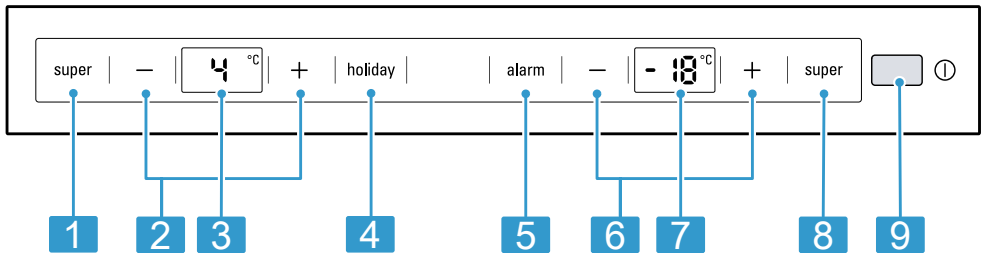

- 1** **super** (Refrigerator compartment) switches Super cooling on or off.

---

- 2** **-/+** (Refrigerator compartment) sets the temperature of the refrigerator compartment.

---

- 3** Displays the set temperature for the refrigerator compartment in °C.

---

- 4** **holiday** switches holiday mode on or off.

---

- 5** **alarm** switches the warning signal off.

- 6** **-/+** (Freezer compartment) sets the temperature of the freezer compartment.

---

- 7** Displays the set temperature for the freezer compartment in °C.

---

- 8** **super** (Freezer compartment) switches Super freezing on or off.

---

- 9** **i** switches the appliance on or off.

## 6 Features

The features of your appliance depend on the model.

### 6.1 Shelf

To vary the shelf as required, you can remove the shelf and re-insert it elsewhere.

→ "Removing the shelf", Page 23

### 6.2 Variable shelf

Use the variable shelf to store tall items, e.g. cans or bottles, on the shelf below.

You can remove the front section of the variable shelf and slide it below the rear part of the shelf.

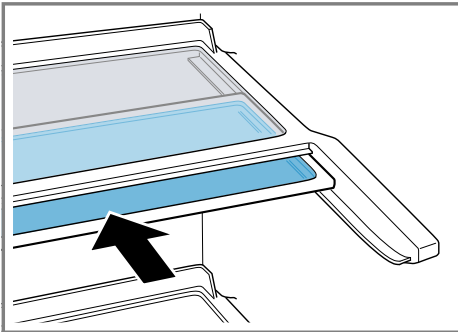

### 6.3 Extendable shelf

In order to achieve an improved overview and to remove food more quickly, remove the shelf.



### 6.4 Fruit and vegetable container with humidity control

Store fresh fruit and vegetables in the fruit and vegetable container. You can adjust the humidity in the fruit and vegetable container using the humidity controller and a special

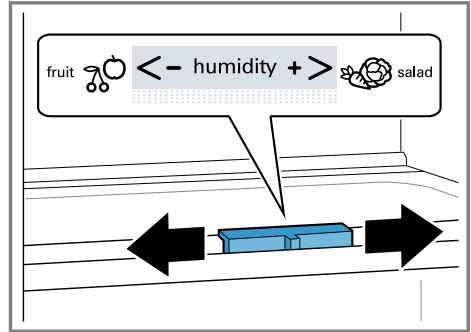
seal. This allows fresh fruit and vegetables to be stored for up to twice as long as with conventional storage.



The air humidity in the fruit and vegetable container can be set according to the type and amount of food to be stored by moving the humidity control:

- Low humidity  required when primarily storing fruit or if the appliance is very full.
- High humidity  required when primarily storing vegetables as well as when the appliance is filled with mixed items or is not very full.

Condensation may form in the fruit and vegetable container depending on the food and quantity stored. Remove the condensation with a dry cloth and adjust the air humidity in the vegetable container using the humidity controller.

To ensure that the quality and aroma are retained, store fruit and vegetables that are sensitive to cold outside of the appliance at temperatures of approx. 8 °C to 12 °C, e.g. pineapple, bananas, citrus fruits, cucumbers, courgettes, peppers, tomatoes and potatoes.

## 6.5 Flat frozen food container

Store flat frozen items, the ice storage container and the ice scoop in the flat frozen food container.

## 6.6 Butter and cheese compartment

Store butter and hard cheese in the butter and cheese compartment.

## 6.7 Door racks

To adjust the door racks as required, you can remove the door rack and re-insert elsewhere.

→ "Removing door racks", Page 23

## 6.8 Accessories

Use original accessories. These have been made especially for your appliance.

The accessories for your appliance depend on the model.

### Egg tray

Store eggs safely on the egg tray.

### Bottle holder

The bottle holder prevents bottles from falling over when the appliance door is opened and closed.

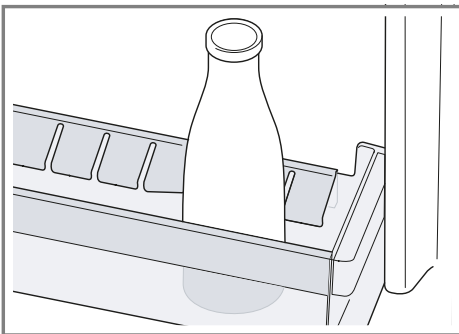

## Freezer tray

You can freeze smaller quantities of food quickly in the freezer drawer, e.g. berries, pieces of fruit, herbs and vegetables.

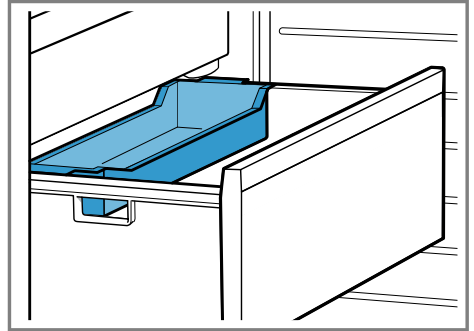

Distribute the frozen food evenly in the frozen food tray and allow to freeze for approx. 10 to 12 hours. Then place in a freezer bag or a freezer box.

### Ice pack

Use the ice pack for temporarily keeping food cool, e.g. in a cool bag.

**Tip:** If a power failure or malfunction occurs, the ice pack can be used to slow down the thawing process for the stored frozen food.

### Ice cube tray

Use the ice cube tray to make ice cubes.

#### Making ice cubes

1. Fill the ice cube tray with water up to  $\frac{3}{4}$  and place in the freezer compartment.

If the ice cube tray is stuck to the freezer compartment, loosen it with a blunt implement only (e.g. spoon handle).

2. To loosen the ice cubes, twist the ice cube tray slightly or hold it briefly under flowing water.

---

## 7 Basic operation

### 7.1 Switching on the appliance

1. Press .
- ✓ The appliance begins to cool.
- ✓ A warning signal sounds, the temperature display (freezer compartment) flashes and alarm lights up because the freezer compartment is still too warm.
2. Switch off the warning signal with alarm.
- ✓ alarm goes out as soon as the set temperature has been reached.
3. Set the required temperature.  
→ Page 16

### 7.2 Operating tips

- Once you have switched on the appliance, the set temperature is only reached after several hours. Do not put any food in the appliance until the temperature has been reached.
- The housing around the freezer compartment is temporarily heated slightly. This prevents condensation in the area of the door seal.
- When you close the door, a vacuum may be created. The door is then difficult to open again. Wait a moment until the vacuum is offset.

### 7.3 Switching off the appliance

- ▶ Press .

## 7.4 Setting the temperature

### Setting the refrigerator compartment temperature

- ▶ Press  $-/+$  (Refrigerator compartment) repeatedly until the temperature display (refrigerator compartment) shows the required temperature.

The recommended temperature in the refrigerator compartment is  $4^{\circ}\text{C}$ .

→ *""OK" sticker", Page 19*

### Setting the freezer compartment temperature

- ▶ Press  $-/+$  (Freezer compartment) repeatedly until the temperature display (freezer compartment) shows the required temperature.

The recommended temperature in the freezer compartment is  $-18^{\circ}\text{C}$ .

---

## 8 Additional functions

### 8.1 Super cooling

With Super cooling, the refrigerator compartment cools so that it is as cold as possible.

Switch on Super cooling before placing large quantities of food in the freezer compartment.

**Note:** When Super cooling is switched on, increased noise may occur.

#### Switching on Super cooling

- ▶ Press **super** (Refrigerator compartment).
- ✓ **super** (Refrigerator compartment) lights up.

**Note:** After approx. 15 hours, the appliance switches to normal operation.

### Switching off Super cooling

- ▶ Press **super** (Refrigerator compartment).
- ✓ The previously set temperature is displayed.

## 8.2 Automatic Super freezing

The automatic Super freezing automatically switches on when warm food is placed in the compartment. With automatic Super freezing, the freezer compartment cools down to a much lower temperature than for normal mode.

If the automatic Super freezing is switched on, **super** (Freezer compartment) lights up and increased noises may occur.

After operation, the appliance switches from automatic Super freezing to normal operation.

### Cancelling automatic Super freezing

- ▶ Press **super** (Freezer compartment).
- ✓ The previously set temperature is displayed.

## 8.3 Manual Super freezing

With Super freezing, the freezer compartment cools so that it is as cold as possible.

Switch on Super freezing four to six hours before placing food weighing 2 kg or more into the freezer compartment.

In order to utilise the freezer capacity, use Super freezing.

→ "Prerequisites for freezing capacity", Page 19

**Note:** When Super freezing is switched on, increased noise may occur.

## Switching on manual Super freezing

- ▶ Press **super** (Freezer compartment).
- ✓ **super** (Freezer compartment) lights up.

**Note:** After approx. 60 hours, the appliance switches to normal operation.

### Switching off manual Super freezing

- ▶ Press **super** (Freezer compartment).
- ✓ The previously set temperature is displayed.

## 8.4 Holiday mode

If you are going to be away for a long time, you can switch on energy-saving holiday mode on the appliance.



### CAUTION

#### Risk of harm to health!

The refrigerator compartment heats up while the vacation mode is switched on. The increased temperature may cause bacteria to increase and spoil the food.

- ▶ When the vacation mode is switched on, do not store any food in the refrigerator compartment.

The appliance automatically sets the temperatures.

Refrigerator compartment	14 °C
Freezer compartment	Temperature remains unchanged

### Switching on vacation mode

- ▶ Press **holiday**.
- ✓ **holiday** lights up.
- ✓ No temperature is shown in the temperature display (refrigerator compartment).

## Switching off vacation mode

- ▶ Press **holiday**.
- ✓ The previously set temperature is displayed.

---

# 9 Alarm

## 9.1 Door alarm

If the appliance door is open for a longer period, the door alarm switches on.

### Switching off the door alarm

- ▶ Close the appliance door or press **alarm**.
- ✓ The warning tone is switched off.

## 9.2 Temperature alarm

If the freezer compartment becomes too warm, the temperature alarm is switched on.

### CAUTION

#### Risk of harm to health!

During the thawing process, bacteria may multiply and spoil the frozen food.

- ▶ Do not refreeze food after it has been defrosted or started to defrost.
- ▶ Refreeze food only after cooking.
- ▶ These items should no longer be stored for the maximum storage period.

The temperature alarm can be switched on in the following cases:

- The appliance is switched on.  
Do not store any food until the appliance has reached the set temperature.
- The freezer compartment door is open for too long.

Check whether the frozen food has defrosted or thawed.

## Switching off the temperature alarm

- ▶ Press **alarm**.
- ✓ The warning tone is switched off.
- ✓ The temperature display (freezer compartment) briefly indicates the warmest temperature reached in the freezer compartment. The temperature display (freezer compartment) then indicates the set temperature again.
- ✓ From this time on, the warmest temperature is measured again and saved.
- ✓ **alarm** lights up until the set temperature is reached again.

---

# 10 Refrigerator compartment

You can keep meat, sausage, fish, dairy products, eggs, prepared meals and pastries in the refrigerator compartment.

The temperature can be set from 2 °C to 8 °C.

The recommended temperature in the refrigerator compartment is 4 °C.

→ *""OK" sticker", Page 19*

The refrigerator compartment can also be used to store highly perishable foods in the short to medium term. The lower the selected temperature, the longer the food remains fresh.

## 10.1 Tips for storing food in the refrigerator compartment

- Only store food when fresh and undamaged.

- Observe the best-before date or use-by date specified by the manufacturer.
- Store food well wrapped or covered.
- Allow hot food and drinks to cool down first before placing in the appliance.

## 10.2 Chill zones in the refrigerator compartment

The air circulation in the refrigerator compartment creates different chill zones.

### Coldest zone

The coldest zone is between the arrow stamped on the side and the shelf underneath.

**Tip:** Store highly perishable food such as fish, sausages and meat in the coldest zone.

### Warmest zone

The warmest zone is at the very top of the door.

**Tip:** Store food that does not spoil easily in the warmest zone, e.g. hard cheese and butter. Cheese can then continue to release its aroma and the butter will still be easy to spread.

## 10.3 "OK" sticker

The "OK" sticker lets you check whether the refrigerator compartment reaches the safe temperature ranges of +4 °C or colder recommended for food.

The "OK" sticker is not included with all models.

If the sticker does not indicate "OK", gradually reduce the temperature.

→ *"Setting the refrigerator compartment temperature", Page 16*

Once the appliance is switched on, it may take up to 12 hours until the set temperature is reached.



Correct setting

---

## 11 Freezer compartment

You can store frozen food, freeze food and make ice cubes in the freezer compartment.

The temperature can be set from -16 °C to -24 °C.

Long-term storage of food should be at -18 °C or lower.

The freezer compartment can be used to store perishable food long-term. The low temperatures slow down or stop the spoilage.

### 11.1 Freezing capacity

The maximum freezing capacity indicates the quantity of food that can be frozen right through to the centre within a specific period of time.

Information on the maximum freezing capacity can be found on the rating plate. → *"Appliance", Fig. 1/5, Page 13*

#### Prerequisites for freezing capacity

1. Approx. 24 hours before placing fresh food in the appliance, switch on Super freezing.  
→ *"Switching on manual Super freezing", Page 17*
2. If the appliance has a flat frozen food container, fill this with food first. For appliances without a flat frozen food container, fill the lowest frozen food container with food first. This is where the food freezes most quickly.

## en Freezer compartment

3. Freeze fresh food as close as possible to the side panels.

### 11.2 Fully utilising the freezer compartment volume

Learn how to store the maximum amount of frozen food in the freezer compartment.

1. Remove all fittings. → *Page 23*
2. Store food directly on the shelves and on the floor of the freezer compartment.

### 11.3 Tips for storing food in the freezer compartment

- To quickly and gently freeze larger quantities of fresh food, place this in the top frozen food container.
- Place the food over the whole area of the compartments or the frozen food containers.
- Do not bring food which is to be frozen into contact with frozen food.
- To ensure that the air can circulate freely in the appliance, push the frozen food containers in as far as they will go.

### 11.4 Freezing smaller amounts of food quickly

1. Place the food in frozen food tray that is attached to the rear of the large frozen food container or in the flat frozen food containers, starting from the right-hand side.
2. Spread the food over a wide area in the freezer compartment.

### 11.5 Tips for freezing fresh food

- Freeze fresh and undamaged food only.
- Freeze food in portions.

- Cooked food is more suitable than food that can be eaten raw.
- Vegetables: Wash, chop up and blanch before freezing.
- Fruit: Wash, pit and perhaps peel, possibly add sugar or ascorbic acid solution.
- Food that is suitable for freezing includes baked items, fish and seafood, meat, game, poultry, eggs without shells, cheese, butter and quark, ready meals and leftovers.
- Food that is unsuitable for freezing includes lettuce, radishes, eggs in shells, grapes, raw apples and pears, yoghurt, sour cream, crème fraîche and mayonnaise.

### Packing frozen food

If you select suitable packaging material and the correct type of packaging, you can determine the product quality and prevent freezer burn.

1. Place the food in the packaging.
2. Squeeze out the air.
3. Pack food airtight to prevent it from losing flavour and drying out.
4. Label the packaging with the contents and the date of freezing.

### 11.6 Shelf life of frozen food at $-18^{\circ}\text{C}$

Food	Storage time
Fish, sausages, prepared meals and baked goods	up to 6 months
Poultry, meat	up to 8 months
Vegetables, fruit	up to 12 months

The imprinted freezer calendar indicates the maximum storage duration in months at a constant temperature of  $-18^{\circ}\text{C}$ .

## 11.7 Defrosting methods for frozen food

### CAUTION

#### Risk of harm to health!

During the thawing process, bacteria may multiply and spoil the frozen food.

- ▶ Do not refreeze food after it has been defrosted or started to defrost.
- ▶ Refreeze food only after cooking.
- ▶ These items should no longer be stored for the maximum storage period.
- Defrost animal-based food, such as fish, meat, cheese, quark, in the refrigerator compartment.
- Defrost bread at room temperature.
- Prepare food for immediate consumption in the microwave, in the oven or on the hob.

---

## 12 Defrosting

### 12.1 Defrosting in the refrigerator compartment

When the appliance is operating, condensation droplets or frost form on the rear panel of the refrigerator compartment due to functional reasons. The back panel in the refrigerator compartment defrosts automatically.

Condensation runs through the condensation channel into the drainage hole to the evaporation pan and does not have to be wiped away.

To ensure that the condensation can drain and odours do not form, observe the following information:

→ *"Cleaning the condensation channel and drainage hole"*, Page 23.

### 12.2 Defrosting in the freezer compartment

The freezer compartment does not defrost automatically. A layer of hoarfrost in the freezer compartment impairs refrigeration of the frozen food and increases power consumption.

#### Defrosting the freezer compartment

Regularly defrost the freezer compartment.

1. Switch on Super freezing approx. four hours before defrosting.

→ *"Switching on manual Super freezing"*, Page 17

This means that the food reaches very low temperatures and it can be stored for longer at room temperature.

2. Remove the frozen food container with the frozen food and temporarily place it in a cool location. Place ice packs (if available) on the frozen food.
3. Switch off the appliance.  
→ *Page 16*
4. Disconnect the appliance from the power supply.  
Unplug the appliance from the mains or switch off the circuit breaker in the fuse box.
5. To accelerate the defrosting process, place a pan of hot water on a trivet in the freezer compartment.
6. Wipe up the condensation water with a soft cloth or sponge.
7. Rub the freezer compartment dry with a soft, dry cloth.
8. Electrically connect the appliance.
9. Switch on the appliance.  
→ *Page 16*
10. Reinsert the frozen food containers with the frozen food.

---

## 13 Cleaning and servicing

To keep your appliance working efficiently for a long time, it is important to clean and maintain it carefully. Customer Service must clean inaccessible points. Cleaning by customer service can give rise to costs.

### 13.1 Preparing the appliance for cleaning

1. Switch off the appliance.  
→ *Page 16*
2. Disconnect the appliance from the power supply.  
Unplug the appliance from the mains or switch off the circuit breaker in the fuse box.
3. Take out all of the food and store it in a cool place.  
Place ice packs (if available) onto the food.
4. If there is a layer of hoarfrost, allow this to defrost.
5. Remove all fittings from the appliance. → *Page 23*
6. Remove the following components from the appliance:
  - → *"Removing the shelf above the fruit and vegetable container", Page 24*

### 13.2 Cleaning the appliance

#### **WARNING**

#### **Risk of electric shock!**

An ingress of moisture can cause an electric shock.

- ▶ Do not use steam- or high-pressure cleaners to clean the appliance.

Liquid in the lighting or in the controls can be dangerous.

- ▶ The rinsing water must not drip into the lighting or controls.

#### **ATTENTION!**

Unsuitable cleaning products may damage the surfaces of the appliance.

- ▶ Do not use hard scouring pads or cleaning sponges.
- ▶ Do not use harsh or abrasive detergents.
- ▶ Do not use cleaning products with a high alcohol content.

If liquid gets into the drainage hole, the evaporation pan may overflow.

- ▶ The rinsing water must not get into the drainage hole.

If you clean fittings and accessories in the dishwasher, this may cause them to become deformed or discoloured.

- ▶ Never clean fittings and accessory in the dishwasher.

1. Prepare the appliance for cleaning.  
→ *Page 22*
2. Clean the appliance, the fittings and the door seals with a dish cloth, lukewarm water and a little pH-neutral washing-up liquid.
3. Dry thoroughly with a soft, dry cloth.
4. Insert the fittings.
5. Electrically connect the appliance.
6. Switch on the appliance.  
→ *Page 16*
7. Putting the food into the appliance.

### 13.3 Cleaning the condensation channel and drainage hole

Regularly clean the condensation channel and drainage hole to ensure that the condensation can drain.

- ▶ Carefully clean the condensation channel and the drainage hole, e.g. using a moistened cotton bud.

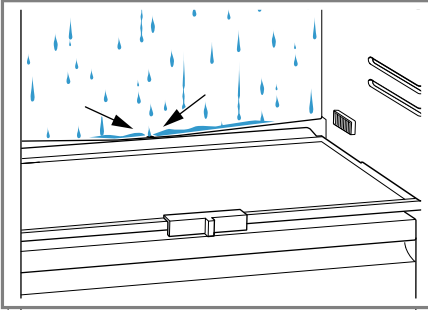

### 13.4 Removing the fittings

If you want to clean the fittings thoroughly, remove these from your appliance.

#### Removing the shelf

- ▶ Pull out and remove the shelf.

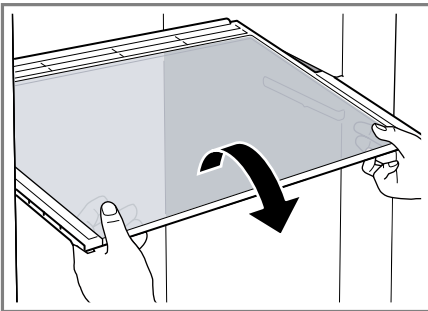

#### Removing the extendable shelf

1. Pull out the extendable shelf until the locking catch is released.

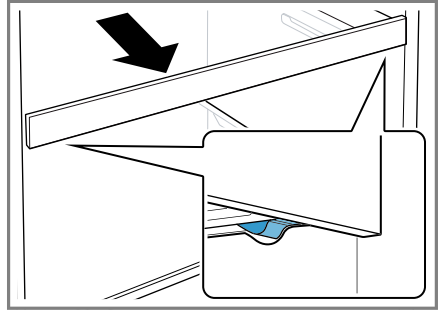

2. Lower the shelf and swing it out to the side.

#### Removing door racks

- ▶ Lift the door rack and remove it.

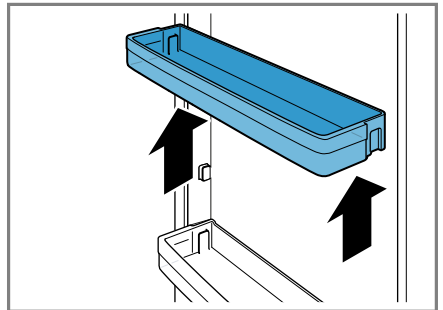

#### Removing the fruit and vegetable container

1. Pull out the fruit and vegetable container as far as it will go.

en Cleaning and servicing

2. Lift the fruit and vegetable container at the front ① and remove it ②.

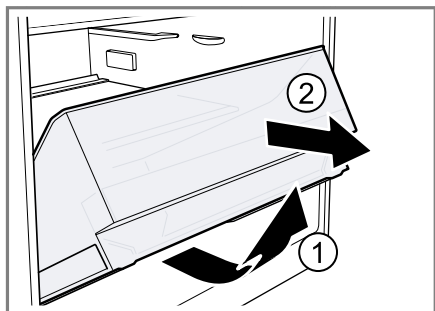

**Removing the shelf above the fruit and vegetable container**

1. Pull out the fruit and vegetable container.
2. Remove the shelf ① and rotate ②.

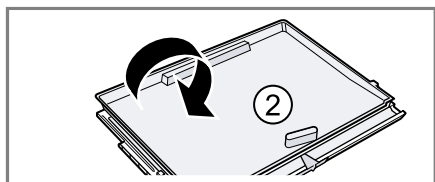
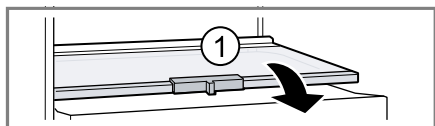

3. Press the fastenings for the lower glass plate outwards.

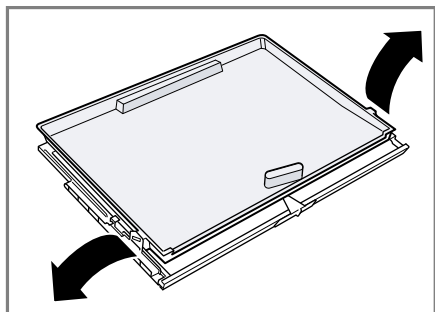

4. Lift the glass plate at the front ① and pull it out at the rear ②.

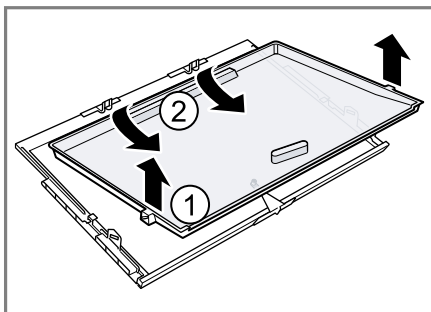

**Removing the frozen food container**

1. Take out the frozen food container as far as it will go.
2. Lift the frozen food container at the front ① and remove it ②.

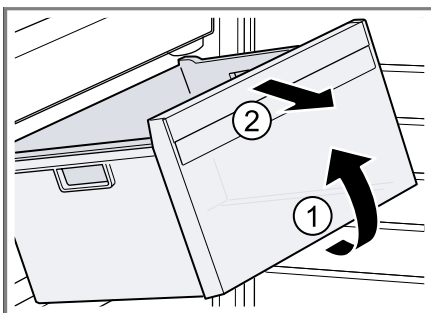

## 14 Troubleshooting

You can rectify minor faults on your appliance yourself. Read the troubleshooting information before contacting after-sales service. This will avoid unnecessary costs.



### WARNING

#### Risk of electric shock!

Incorrect repairs are dangerous.

- ▶ Repairs to the appliance should only be carried out by trained specialist staff.
- ▶ Only use genuine spare parts when repairing the appliance.
- ▶ If the power cord of this appliance is damaged, it must be replaced by the manufacturer, the manufacturer's Customer Service or a similarly qualified person in order to prevent any risk.

Fault	Cause and troubleshooting
The appliance is not cooling, the displays and lighting light up.	Showroom mode is switched on. <ul style="list-style-type: none"> <li>▶ Carry out the appliance self-test. → <i>Page 28</i></li> <li>✓ Once the appliance self-test has ended, the appliance switches to normal operation.</li> </ul>
The LED lighting does not work.	Different causes are possible. <ul style="list-style-type: none"> <li>▶ Call customer service.</li> </ul> The customer service number can be found in the enclosed customer service directory.
The base of the refrigerator compartment is wet.	The condensation channel or drainage hole are blocked. <ul style="list-style-type: none"> <li>▶ Clean the condensation channel and the drainage hole. → <i>Page 23</i></li> </ul>
E or d appears in the temperature display.	The electronics have detected a fault. <ol style="list-style-type: none"> <li>1. Switch off the appliance. → <i>Page 16</i></li> <li>2. Disconnect the appliance from the mains.                             <ul style="list-style-type: none"> <li>Unplug the appliance from the mains or switch off the circuit breaker in the fuse box.</li> </ul> </li> <li>3. Reconnect the appliance after five minutes.</li> <li>4. If the message still appears on the display, call customer service.</li> </ol> The customer service number can be found in the enclosed customer service directory.

Fault	Cause and troubleshooting
The temperature display (freezer compartment) flashes.	<p>The temperature in the freezer compartment was too warm.</p> <ol style="list-style-type: none"> <li>1. Press alarm. <ul style="list-style-type: none"> <li>✓ The temperature display (freezer compartment) briefly indicates the warmest temperature reached in the freezer compartment. The temperature display (freezer compartment) then indicates the set temperature again.</li> </ul> </li> <li>2. Press alarm. <ul style="list-style-type: none"> <li>✓ The temperature display (freezer compartment) no longer flashes.</li> </ul> </li> </ol>
The temperature display (freezer compartment) flashes, a warning signal sounds and alarm lights up.	<p>Different causes are possible.</p> <ul style="list-style-type: none"> <li>▶ Press alarm.</li> <li>✓ The alarm is switched off.</li> </ul> <hr/> <p>The appliance door is open.</p> <ul style="list-style-type: none"> <li>▶ Close the appliance door.</li> </ul> <hr/> <p>The exterior ventilation grilles are blocked.</p> <ul style="list-style-type: none"> <li>▶ Remove any obstructions from in front of the exterior ventilation grilles.</li> </ul> <hr/> <p>Larger quantities of fresh food have been put in.</p> <ul style="list-style-type: none"> <li>▶ Do not exceed the max. freezing capacity. → "Freezing capacity", Page 19</li> </ul>
The temperature differs greatly from the setting.	<p>Different causes are possible.</p> <ol style="list-style-type: none"> <li>1. Switch off the appliance. → Page 16</li> <li>2. Switch the appliance back on after five minutes. → Page 16 <ul style="list-style-type: none"> <li>– If the temperature is too warm, check the temperature again after a couple of hours.</li> <li>– If the temperature is too cold, check the temperature again on the following day.</li> </ul> </li> </ol>
The appliance hums, bubbles, buzzes, gargles or clicks.	<p>Not a fault. A motor is running, e.g. refrigerating unit, fan. Refrigerant flows through the pipes. The motor, switches or solenoid valves are switching on or off. No action required.</p>
The appliance makes noises.	<p>Fittings wobble or stick.</p> <ul style="list-style-type: none"> <li>▶ Check the removable fittings and, if required, replace these.</li> </ul> <hr/> <p>Bottles or containers are touching.</p> <ul style="list-style-type: none"> <li>▶ Move the bottles or containers away from each other.</li> </ul> <hr/> <p>Super freezing is switched on.</p>

<b>Fault</b>	<b>Cause and troubleshooting</b>
The appliance makes noises.	No action required.

## 14.1 Power failure

During a power failure, the temperature in the appliance rises; this reduces the storage time and the quality of the frozen food.

The stored frozen food is cooled to the temperature increase time specified on the rating plate. → "Appliance", Fig. **1/5**, Page 13

### Notes

- Open the appliance as little as possible during a power failure and do not place any other food in the appliance.
- Check the quality of the food immediately after a power failure.
  - Dispose of any frozen food that has defrosted and is hotter than 5 °C.
  - Cook or fry slightly thawed frozen food, and then either consume it or freeze it again.

## 14.2 Conducting an appliance self-test

1. Switch off the appliance.  
→ Page 16
2. Switch the appliance back on after approx. five minutes. → Page 16
3. Within the first 10 seconds after switching on, press and hold **super** (Freezer compartment) for 3 to 5 seconds until an audible signal sounds.
  - ✓ The appliance self-test starts.
  - ✓ While the appliance self-test is running, a long audible signal sounds.
  - ✓ If, at the end of the appliance self-test, two audible signals sound and the temperature display indicates the set temperature, your appliance is OK. The appliance switches to normal operation.

- ✓ If, at the end of the appliance self-test, five audible signals sound and **super** (Freezer compartment) flashes for 10 seconds, inform the after-sales service.

---

## 15 Storage and disposal

You can find out here how to prepare your appliance for storage. You will also find out how to dispose of old appliances.

### 15.1 Switching off the appliance

1. Switch off the appliance.  
→ Page 16
2. Disconnect the appliance from the power supply.  
Unplug the appliance from the mains or switch off the circuit breaker in the fuse box.
3. Remove all of the food.
4. Defrost the appliance. → Page 21
5. Clean the appliance. → Page 22
6. To ensure the ventilation inside the appliance, leave the appliance open.

### 15.2 Disposing of old appliance

Valuable raw materials can be re-used by recycling.

#### **WARNING** **Risk of harm to health!**

Children can lock themselves in the appliance, thereby putting their lives at risk.

- ▶ Leave shelves and containers inside the appliance to prevent children from climbing in.
- ▶ Keep children away from the redundant appliance.

**⚠ WARNING****Risk of fire!**

If the tubes are damaged, flammable refrigerant and harmful gases may escape and ignite.

- ▶ Do not damage the tubes of the refrigerant circuit or the insulation.
1. Unplug the appliance from the mains.
  2. Cut through the power cord.
  3. Dispose of the appliance in an environmentally friendly manner.

Information about current disposal methods are available from your specialist dealer or local authority.



This appliance is labelled in accordance with European Directive 2012/19/EU concerning used electrical and electronic appliances (waste electrical and electronic equipment - WEEE). The guideline determines the framework for the return and recycling of used appliances as applicable throughout the EU.

---

## 16 Customer Service

If you have any queries, are unable to rectify faults on the appliance yourself or if your appliance needs to be repaired, contact Customer Service. Function-relevant genuine spare parts according to the corresponding Eco-design Order can be obtained from Customer Service for a period of at least 10 years from the date on which your appliance was placed on the market within the European Economic Area.

**Note:** Under the terms of the manufacturer's warranty applicable to the location, the use of Customer Service is free of charge. The minimum duration of the warranty (manufacturer's warranty for private consumers) in the European Economic Area is 2 years according to the terms of warranty applicable to the location. The terms of warranty do not affect other rights or claims held by yourself under local legislation.

Detailed information on the warranty period and terms of warranty in your country is available from our after-sales service, your retailer or on our website.

If you contact Customer Service, you will require the product number (E-Nr.) and the production number (FD) of your appliance.

The contact details for Customer Service can be found in the enclosed Customer Service directory or on our website.

### 16.1 Product number (E-Nr.) and production number (FD)

You can find the product number (E-Nr.) and the production number (FD) on the appliance's rating plate.

→ "Appliance", Fig. **1/5**, Page 13  
 Make a note of your appliance's details and the Customer Service telephone number to find them again quickly.

---

## 17 Technical data

Refrigerant, cubic capacity and further technical specifications can be found on the rating plate.

→ "Appliance", Fig. **1/5**, Page 13

More information about your model can be found online at <https://energylabel.bsh-group.com><sup>1</sup>. This web address is linked to the official EU EPREL product database. At the time of printing its web address had not yet been published. Please then follow the instructions on searching for models. The model identifier is made up of the characters before the slash in the product number (E-Nr.) on the rating plate. Alternatively you can also find the model identifier in the first line of the EU energy label.

---

<sup>1</sup> Only applies to countries in the European Economic Area



**BSH Hausgeräte GmbH**

Carl-Wery-Straße 34

81739 München

GERMANY

[www.siemens-home.bsh-group.com](http://www.siemens-home.bsh-group.com)

Manufactured by BSH Hausgeräte GmbH under the trademark licence of Siemens AG



**9001590822**

(001023)

en