

on/off

menu



start/stop

SIEMENS

SIEMENS

## Built-in oven

HB678GB.6M

[en] Instruction manual



Register your product on My Siemens and discover exclusive services and offers.  
[siemens-home.bsh-group.com/welcome](https://siemens-home.bsh-group.com/welcome)

The future moving in.

Siemens Home Appliances



# Table of contents

|   |    |   |    |
|---|----|---|----|
|  <b>Intended use</b> . . . . .                      | 4  |  <b>Meat thermometer</b> . . . . .   | 17 |
|  <b>Important safety information</b> . . . . .      | 5  | Types of heating . . . . .  | 17 |
| General information . . . . .   | 5  | Inserting the meat probe into the food . . . . .  | 17 |
| Meat thermometer . . . . .  | 5  | Setting the core temperature . . . . .  | 18 |
| Cleaning function . . . . .   | 6  | Core temperatures of different foods . . . . .  | 18 |
|  <b>Causes of damage</b> . . . . .                  | 6  |  <b>Sabbath mode</b> . . . . .       | 19 |
| General information . . . . .   | 6  | Starting Sabbath mode . . . . .   | 19 |
|  <b>Environmental protection</b> . . . . .          | 7  |  <b>Cleaning function</b> . . . . .  | 19 |
| Saving energy . . . . .   | 7  | Before running the cleaning function . . . . .  | 19 |
| Environmentally-friendly disposal . . . . .   | 7  | Setting the self-cleaning function . . . . .  | 20 |
|  <b>Getting to know your appliance</b> . . . . .    | 8  | Once the cleaning function has ended . . . . .  | 20 |
| Control panel . . . . .   | 8  |  <b>Home Connect</b> . . . . .       | 20 |
| Controls . . . . .  | 8  | Setting up . . . . .  | 20 |
| Display . . . . .   | 8  | Remote Start . . . . .  | 21 |
| Operating modes menu . . . . .  | 9  | Home Connect settings . . . . .   | 21 |
| Types of heating . . . . .  | 9  | Remote diagnostics . . . . .  | 21 |
| Further information . . . . .   | 10 | About data protection . . . . .   | 21 |
| Cooking compartment functions . . . . .   | 10 | Declaration of Conformity . . . . .   | 21 |
|  <b>Accessories</b> . . . . .                     | 11 |  <b>Cleaning</b> . . . . .          | 22 |
| Accessories included . . . . .  | 11 | Suitable cleaning agents . . . . .  | 22 |
| Inserting accessories . . . . .   | 11 | Keeping the appliance clean . . . . .   | 23 |
| Optional accessories . . . . .  | 12 |  <b>Rails</b> . . . . .            | 23 |
|  <b>Before using for the first time</b> . . . . . | 12 | Detaching and refitting the rails . . . . .   | 23 |
| Initial use . . . . .   | 12 |  <b>Appliance door</b> . . . . .   | 24 |
| Cleaning the cooking compartment and accessories  | 13 | Removing and fitting the appliance door . . . . .   | 24 |
|  <b>Operating the appliance</b> . . . . .         | 13 | Removing the door cover . . . . .   | 25 |
| Switching the appliance on and off . . . . .  | 13 | Removing and installing the door panels . . . . .   | 25 |
| Starting or interrupting operation . . . . .  | 13 |  <b>Trouble shooting</b> . . . . . | 27 |
| Selecting an operating mode . . . . .   | 13 | Fault table . . . . .   | 27 |
| Setting the type of heating and temperature . . . . .   | 13 | Maximum operating time exceeded . . . . .   | 27 |
| Rapid heat up . . . . .   | 14 | Cooking compartment bulbs . . . . .   | 27 |
|  <b>Time-setting options</b> . . . . .            | 14 |  <b>Customer service</b> . . . . . | 28 |
| Timer . . . . .   | 15 | E number and FD number . . . . .  | 28 |
| Cooking time . . . . .  | 15 |  <b>Dishes</b> . . . . .           | 28 |
| End time . . . . .  | 15 | Information on the settings . . . . .   | 28 |
|  <b>Childproof lock</b> . . . . .                 | 16 | Meat thermometer . . . . .  | 28 |
| Activating and deactivating . . . . .   | 16 | Selecting a dish . . . . .  | 29 |
| The appliance door is locked . . . . .  | 16 | Baking sensor . . . . .   | 29 |
|  <b>Basic settings</b> . . . . .                  | 16 | Applying settings for dishes . . . . .  | 29 |
| Changing settings . . . . .   | 16 |   |    |
| List of settings . . . . .  | 16 |   |    |
| Changing the time . . . . .   | 17 |   |    |





**Tested for you in our cooking studio. . . . . 30**

Do not use silicone moulds . . . . . 30  
 Cakes and small baked items . . . . . 30  
 Bread and rolls. . . . . 34  
 Pizza, quiche and savoury cakes . . . . . 35  
 Bakes and soufflés. . . . . 37  
 Poultry . . . . . 38  
 Meat . . . . . 40  
 Fish . . . . . 42  
 Vegetables and side dishes. . . . . 43  
 Yogurt . . . . . 44  
 Eco heating functions. . . . . 44  
 Acrylamide in foodstuffs. . . . . 46  
 Slow cook . . . . . 46  
 Drying. . . . . 47  
 Preserving . . . . . 48  
 Prove dough. . . . . 49  
 Defrosting. . . . . 49  
 Keeping warm . . . . . 50  
 Test dishes. . . . . 50

Additional information on products, accessories, replacement parts and services can be found at [www.siemens-home.bsh-group.com](http://www.siemens-home.bsh-group.com) and in the online shop [www.siemens-home.bsh-group.com/eshops](http://www.siemens-home.bsh-group.com/eshops)



**Intended use**

Read these instructions carefully. Only then will you be able to operate your appliance safely and correctly. Retain the instruction manual and installation instructions for future use or for subsequent owners.

This appliance is only intended to be fully fitted in a kitchen. Observe the special installation instructions.

Check the appliance for damage after unpacking it. Do not connect the appliance if it has been damaged in transport.

Only a licensed professional may connect appliances without plugs. Damage caused by incorrect connection is not covered under warranty.

This appliance is intended for domestic use only. The appliance must only be used for the preparation of food and drink. The appliance must be supervised during operation. Only use this appliance indoors.

This appliance is intended for use up to a maximum height of 4000 metres above sea level.

This appliance may be used by children over the age of 8 years old and by persons with reduced physical, sensory or mental capabilities or by persons with a lack of experience or knowledge if they are supervised or are instructed by a person responsible for their safety how to use the appliance safely and have understood the associated hazards.

Children must not play with, on, or around the appliance. Children must not clean the appliance or carry out general maintenance unless they are at least 15 years old and are being supervised.

Keep children below the age of 8 years old at a safe distance from the appliance and power cable.

Always slide accessories into the cooking compartment the right way round.

→ "Accessories" on page 11

## Important safety information

### General information

#### Warning – Risk of fire!

- Combustible items stored in the cooking compartment may catch fire. Never store combustible items in the cooking compartment. Never open the appliance door if there is smoke inside. Switch off the appliance and unplug it from the mains or switch off the circuit breaker in the fuse box.
- Loose food remnants, fat and meat juices may catch fire. Before using the appliance, remove the worst of the food remnants from the cooking compartment, heating elements and accessories.
- A draught is created when the appliance door is opened. Greaseproof paper may come into contact with the heating element and catch fire. Do not place greaseproof paper loosely over accessories during preheating. Always weight down the greaseproof paper with a dish or a baking tin. Only cover the surface required with greaseproof paper. Greaseproof paper must not protrude over the accessories.

#### Warning – Risk of burns!

- The appliance becomes very hot. Never touch the interior surfaces of the cooking compartment or the heating elements. Always allow the appliance to cool down. Keep children at a safe distance.
- Accessories and ovenware become very hot. Always use oven gloves to remove accessories or ovenware from the cooking compartment.
- Alcoholic vapours may catch fire in the hot cooking compartment. Never prepare food containing large quantities of drinks with a high alcohol content. Only use small quantities of drinks with a high alcohol content. Open the appliance door with care.

#### Warning – Risk of scalding!

- The accessible parts become hot during operation. Never touch the hot parts. Keep children at a safe distance.
- When you open the appliance door, hot steam can escape. Steam may not be visible, depending on its temperature. When opening, do not stand too close to the appliance. Open the appliance door carefully. Keep children away.

- Water in a hot cooking compartment may create hot steam. Never pour water into the cooking compartment when the cooking compartment is hot.

#### Warning – Risk of injury!

- Scratched glass in the appliance door may develop into a crack. Do not use a glass scraper, sharp or abrasive cleaning aids or detergents.
- The hinges on the appliance door move when opening and closing the door, and you may be trapped. Keep your hands away from the hinges.

#### Warning – Risk of electric shock!

- Incorrect repairs are dangerous. Repairs may only be carried out and damaged power cables replaced by one of our trained after-sales technicians. If the appliance is defective, unplug the appliance from the mains or switch off the circuit breaker in the fuse box. Contact the after-sales service.
- The cable insulation on electrical appliances may melt when touching hot parts of the appliance. Never bring electrical appliance cables into contact with hot parts of the appliance.
- Do not use any high-pressure cleaners or steam cleaners, which can result in an electric shock.
- A defective appliance may cause electric shock. Never switch on a defective appliance. Unplug the appliance from the mains or switch off the circuit breaker in the fuse box. Contact the after-sales service.

#### Warning – Hazard due to magnetism!

Permanent magnets are used in the control panel or in the control elements. They may affect electronic implants, e.g. heart pacemakers or insulin pumps. Wearers of electronic implants must stay at least 10 cm away from the control panel.

### Meat thermometer

#### Warning – Risk of electric shock!

The insulation of an incompatible meat thermometer may be damaged. Only use the meat thermometer which is recommended for this appliance.

## Cleaning function

### Warning – Risk of fire!

- Loose food residues, grease and meat juices may catch fire during the cleaning function. Before starting the cleaning function, remove coarse dirt from the cooking compartment and from the accessories.
- The appliance will become very hot on the outside during the cleaning function. Never hang combustible objects, e.g. tea towels, on the door handle. Do not place anything against the front of the appliance. Keep children away from the appliance.
- If the door seal is damaged, a large amount of heat will be generated around the door. Do not scrub or remove the seal. Never operate the appliance if the seal is damaged or missing.

### Warning – Risk of serious damage to health!

The appliance will become very hot during the cleaning function. The non-stick coating on baking trays and tins is destroyed and noxious gases are released. Never clean non-stick baking trays and baking tins using the cleaning function. Only clean enamelled accessories using the cleaning function.

### Warning – Risk of harm to health!

The cleaning function heats up the cooking compartment to a very high temperature so that food remnants left over from roasting, grilling and baking will burn off. This process releases vapours, which can irritate the mucous membranes. While the cleaning function is running, keep the kitchen well ventilated. Do not remain in the room for long periods. Keep children and pets away. Follow the instructions even when using the Delayed start function with a delayed end time.

### Warning – Risk of burns!

- The cooking compartment becomes extremely hot during the cleaning function. Never open the appliance door. Allow the appliance to cool down. Keep children away from the appliance.
-  The appliance becomes very hot on the outside during the cleaning function. Never touch the appliance door. Allow the appliance to cool down. Keep children at a safe distance.

## Causes of damage

### General information

#### Caution!

- Accessories, foil, greaseproof paper or ovenware on the cooking compartment floor: do not place accessories on the cooking compartment floor. Do not cover the cooking compartment floor with any sort of foil or greaseproof paper. Do not place ovenware on the cooking compartment floor if a temperature of over 50 °C has been set. This will cause heat to accumulate. The baking and roasting times will no longer be correct and the enamel will be damaged.
- Aluminium foil: Aluminium foil in the cooking compartment must not come into contact with the door glass. This could cause permanent discolouration of the door glass.
- Silicone bakeware: Do not use silicone moulds or reusable baking tray liners, covers or accessories that contain silicone. Otherwise, the baking sensor may be damaged. Greaseproof paper with a silicone coating can be used.
- Water in a hot cooking compartment: do not pour water into the cooking compartment when it is hot. This will cause steam. The temperature change can cause damage to the enamel.
- Moisture in the cooking compartment: Over an extended period of time, moisture in the cooking compartment may lead to corrosion. Allow the cooking compartment to dry after use. Do not keep moist food in the closed cooking compartment for extended periods of time. Do not store food in the cooking compartment.
- Cooling with the appliance door open: Following operation at high temperatures, only allow the cooking compartment to cool down with the door closed. Do not trap anything in the appliance door. Even if the door is only left open a crack, the front of nearby furniture may become damaged over time. Only leave the cooking compartment to dry with the door open if a lot of moisture was produced whilst the oven was operating.
- Fruit juice: when baking particularly juicy fruit pies, do not pack the baking tray too generously. Fruit juice dripping from the baking tray leaves stains that cannot be removed. If possible, use the deeper universal pan.
- Oven cleaner: Never use oven cleaner in the cooking compartment when it is still warm. This may damage the enamel. Remove all food remnants from the cooking compartment and the appliance door before you next heat up the appliance.
- Extremely dirty seal: If the seal is very dirty, the appliance door will no longer close properly during operation. The fronts of adjacent units could be damaged. Always keep the seal clean. Never operate the appliance if the seal is damaged or missing. → "Cleaning" on page 22
- Appliance door as a seat, shelf or worktop: Do not sit on the appliance door, or place or hang anything on it. Do not place any cookware or accessories on the appliance door.

- Inserting accessories: depending on the appliance model, accessories can scratch the door panel when closing the appliance door. Always insert the accessories into the cooking compartment as far as they will go.
- Carrying the appliance: do not carry or hold the appliance by the door handle. The door handle cannot support the weight of the appliance and could break.

## Environmental protection

Your new appliance is particularly energy-efficient. Here you can find tips on how to save even more energy when using the appliance, and how to dispose of your appliance properly.

### Saving energy

- Only preheat the appliance if this is specified in the recipe or in the tables in the operating instructions.
- Leave frozen food to defrost before placing it in the cooking compartment.

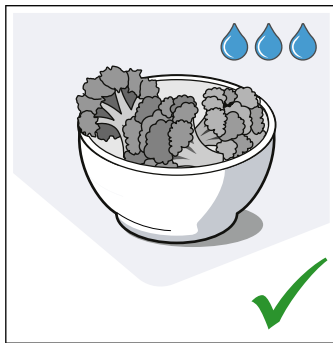
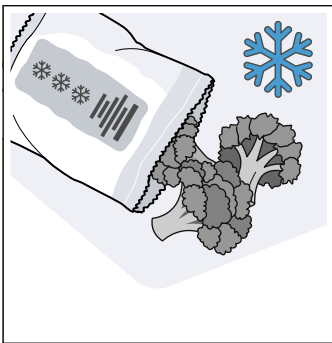

- Use baking tins that are dark-coloured, painted black or have an enamel coating. These absorb the heat particularly well.

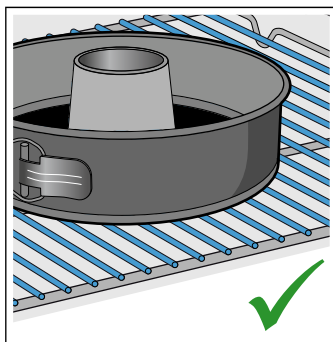
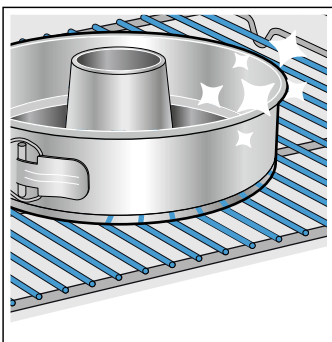

- Remove any unnecessary accessories from the cooking compartment.

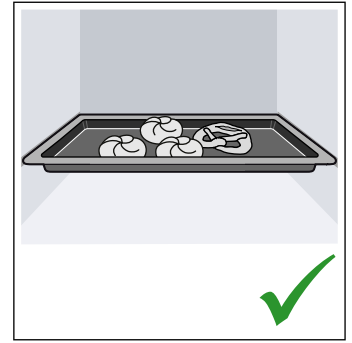
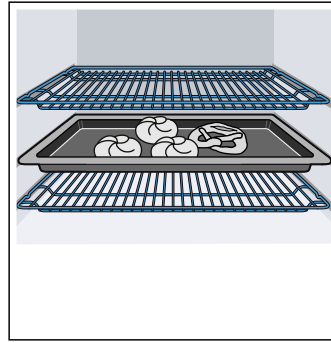

- Open the appliance door as infrequently as possible when the appliance is in use.

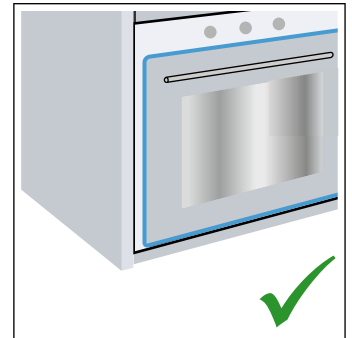
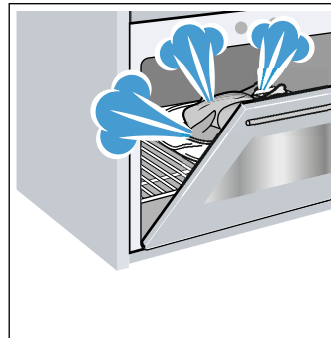

- It is best to bake several cakes one after the other. The cooking compartment stays warm. This reduces the baking time for the second cake. You can place two cake tins next to each other in the cooking compartment.

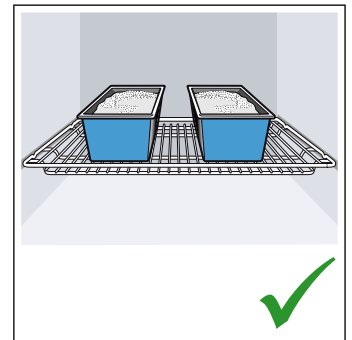
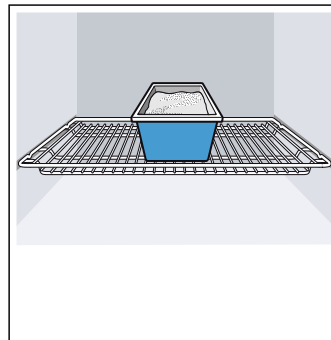

- For longer cooking times, you can switch the appliance off 10 minutes before the end of the cooking time and use the residual heat to finish cooking.

### Environmentally-friendly disposal

Dispose of packaging in an environmentally-friendly manner.



This appliance is labelled in accordance with European Directive 2012/19/EU concerning used electrical and electronic appliances (waste electrical and electronic equipment - WEEE). The guideline determines the framework for the return and recycling of used appliances as applicable throughout the EU.

## Getting to know your appliance

In this section, we will explain the indicators and controls. You will also find out about the various functions of your appliance.

**Note:** Depending on the appliance model, individual details and colours may differ.

### Control panel

In the control panel, you can use the various buttons and the rotary selector to set the required function of the appliance. The current settings are shown on the display.

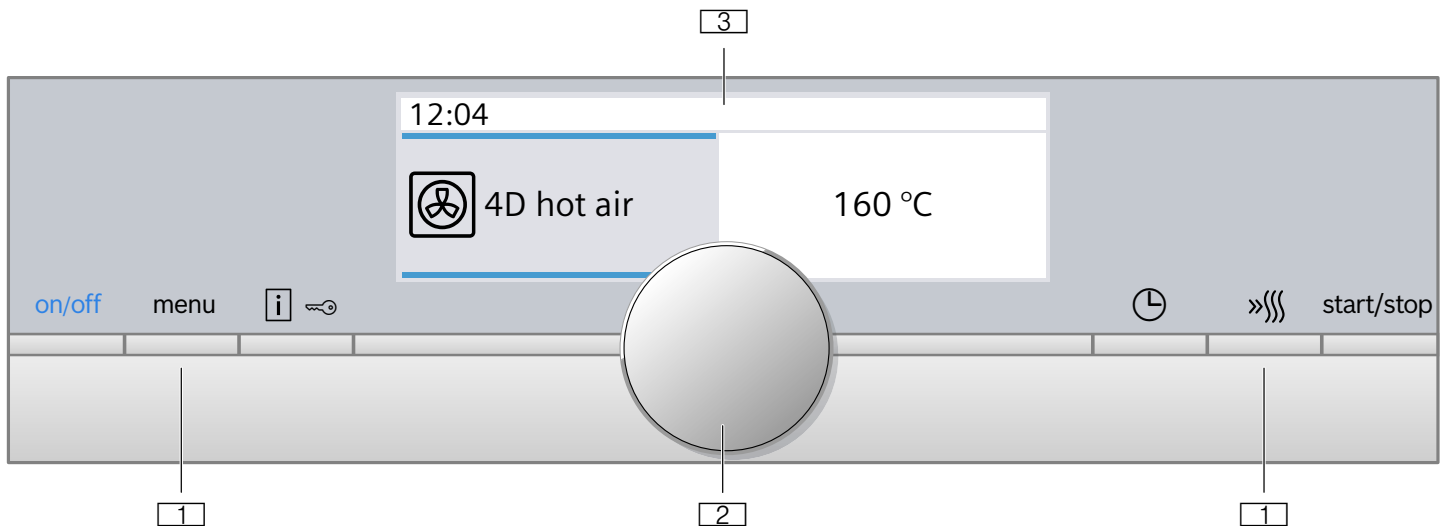

#### 1 Buttons

The buttons to the left and right of the rotary selector have a pressure point. Press these buttons to activate them.

#### 2 Rotary selector

You can turn the rotary selector clockwise and anti-clockwise.

#### 3 Touch display

You can see the current adjustment values, options or notes in the touch display. To implement settings, touch the appropriate text field. The text fields change depending on the selection.

Start/Stop

Starts, pauses or cancels operation

### Rotary selector

Use the rotary selector to change the adjustment values shown in the display.

In most selection lists, e.g. types of heating, the first selection follows the last. For temperature, for example, you must turn the rotary selector back when the minimum or maximum temperature is reached.

### Display

The display is structured so that the information can be read at a glance.

The value that you can currently set is in focus. It is displayed in white lettering with a dark background.

### Status bar

The status bar is at the top of the display. The time and set time functions are displayed here.

### Progress line

The progress line shows you how much the oven has already heated up or how much time has elapsed, for example. The straight line below the in-focus value progresses from left to right, the longer the operation continues to run.

### Countdown

If you have started your appliance without a cooking time, you can see how long the operation has already been running for at the top right in the status bar.

## Controls

The individual controls are adapted for the various functions of your appliance. You can set your appliance simply and directly.

### Buttons

Here you can find a short explanation of the various buttons.

| Buttons | Meaning   |
|---------|---|
| on/off  | Switches the appliance on and off   |
| menu    | Menu<br>Opens the operating modes menu  |
|         | Information<br>Displays notes<br>Childproof lock<br>Activates/deactivates the childproof lock |
|         | Time-setting options<br>Opens the time-setting options menu                                   |
|         | Rapid heat up<br>Switches rapid heat up on and off  |



If you had set a cooking time and it was deleted, the countdown applies the time that has already elapsed and continues to count down from this time. You can therefore always check how long the operation has already been running.

### Temperature indicator







The temperature indicator bars show the heating phases or residual heat in the cooking compartment.

|                         |  |
|-------------------------|--|
| Heating indicator       | The heating indicator displays the rising temperature in the cooking compartment. When all bars are filled, the optimum time for placing the dish in the oven has been reached.<br>The bars do not appear when settings are applied for grilling and cleaning. |
| Residual heat indicator | When the appliance is switched off, the temperature indicator shows the residual heat in the cooking compartment. Once the temperature has dropped to approximately 60 °C, the display goes out.   |

**Note:** Due to thermal inertia, the temperature displayed may be slightly different to the actual temperature inside the oven. You can use the  button to check the current heating temperature when heating up.

### Types of heating

To make sure that you always use the right type of heating to cook your food, we have explained the differences and applications below.

| Types of heating  | Temperature  | Use   |
|---|--|---|
|  4D hot air             | 30-275 °C  | For baking and roasting on one or more levels.<br>The fan distributes the heat from the ring heating element in the back panel evenly around the cooking compartment.   |
|  Top/bottom heating     | 30-300 °C  | For traditional baking and roasting on one level. Especially suitable for cakes with moist toppings.<br>Heat is emitted evenly from above and below.  |
|  Hot air eco            | 30-275 °C  | For gently cooking selected types of food on one level without preheating.<br>The fan distributes the heat from the ring-shaped heating element in the back panel around the cooking compartment.<br>This heating function is most effective between 125 and 275 °C.<br>This heating function is used to measure both the energy consumption in air circulation mode and the energy efficiency class. |
|  Top/bottom heating eco | 30-300 °C  | For gently cooking selected types of food on one level.<br>Heat is emitted from above and below.<br>This heating function is most effective between 150 and 250 °C.<br>This heating function is used to measure the energy consumption in the conventional mode.  |
|  Hot air grilling       | 30-300 °C  | For roasting poultry, whole fish and larger pieces of meat.<br>The grill heating element and the fan switch on and off alternately. The fan circulates the hot air around the food.   |
|  Grill, large area      | Grill settings:<br>1 = low<br>2 = medium<br>3 = high | For grilling flat items such as steaks, sausages or bread, and for browning food.<br>The whole area of the grill heating element becomes hot.   |









### Operating modes menu

The menu is divided into different operating modes. In this way, you can quickly access the required function.

Depending on the appliance type, there are a various number of operating modes. In the status bar at the top right, you can see how many pages there are in the operating modes menu. If 1/2 is displayed in the status bar, then you are on the first page of two pages.

| Operating mode                                 | Use  |
|--|--|
| Types of heating                               | There are several finely tuned types of heating for you to prepare your dishes.    |
| Dishes → "Dishes" on page 28                   | Here you can find preprogrammed setting values which are suitable for many dishes. |
| Self-cleaning → "Cleaning function" on page 19 | The self-cleaning function cleans your oven automatically.                         |
| Settings → "Basic settings" on page 16         | You can adapt your appliance's basic settings to suit your needs.                  |
| HomeConnect → "Home Connect" on page 20        | This function allows you to connect your oven with a mobile device.                |

For temperature settings above 275 °C and grill setting 3, the appliance reduces the temperature to approx. 275 °C or grill setting 1 after approx. 40 minutes.

|   |                     |  |   |
|---|---------------------|--|---|
|  | Grill, small area   | Grill settings:<br>1 = low<br>2 = medium<br>3 = high | For grilling small quantities of food such as steaks, sausages or bread, and for browning food.<br>The centre part under the grill heating element becomes hot.   |
|  | Pizza setting       | 30-275 °C  | For preparing pizza and dishes which require a lot of heat from underneath.<br>The bottom heating element and the ring heating element in the back panel heat up.   |
|  | Intensive heat      | 30-300 °C  | For dishes with a crispy base.<br>The heat is emitted from above and more intensively from below.   |
|  | Slow cooking        | 70-120 °C  | For gentle and slow cooking of seared, tender pieces of meat in ovenware without a lid.<br>The heat is emitted evenly from the top and bottom at low temperatures.  |
|  | Bottom heating      | 30-250 °C  | For cooking in a bain marie and for the final baking stage.<br>The heat is emitted from below.  |
|  | Drying              | 30-150 °C  | For drying herbs fruit and vegetables.  |
|  | Keeping warm        | 60-100 °C  | For keeping cooked food warm.   |
|  | Preheating ovenware | 30-70 °C   | For preheating ovenware.  |
|  | CoolStart function  | 30-275 °C  | For the quick preparation of frozen products on level 3. The temperature depends on the manufacturer's instructions. Use the highest temperature specified on the packaging. The cooking time is as specified or shorter. Preheating is not required. |

### Default values

For each type of heating, the appliance specifies a default temperature or level. You can accept this value or change it in the appropriate area.

### Further information

In most cases, the appliance provides notes and further information on the action just carried out. To do this, press the  button. The note is shown for a few seconds.

Some notes are displayed automatically, for example as confirmation, or to provide an instruction or warning.

### Cooking compartment functions

Some functions make your appliance easier to use. This, for example, enables the cooking compartment to be well lit and a cooling fan to prevent the appliance from overheating.

#### Opening the appliance door

If you open the appliance door during an operation, the operation is paused. The operation resumes when you close the door.

**Note:** When using the Microwave operating mode, you must touch the start/stop button once the door has been closed to resume the operation. You can change the basic setting for this.

#### Interior lighting

When you open the appliance door, the interior lighting switches on. If the door remains open for longer than 15 minutes, the lighting switches off again.

For most operating modes, the interior lighting switches on as soon as the operation is started. When the operation has finished, the lighting switches off.

**Note:** You can set the interior lighting not to come on during the operation in the basic settings.

#### Cooling fan

The cooling fan switches on and off as required. The hot air escapes above the door.

#### Caution!

Do not cover the ventilation slots. Otherwise the oven will overheat.

So that the cooking compartment cools down more quickly after operation, the cooling fan continues to run for a certain period afterwards.

**Note:** You can change how long the cooling fan continues to run for in the basic settings. → "Basic settings" on page 16

## Accessories

Your appliance is accompanied by a range of accessories. Here, you can find an overview of the accessories included and information on how to use them correctly.

### Accessories included

Your appliance is equipped with the following accessories:

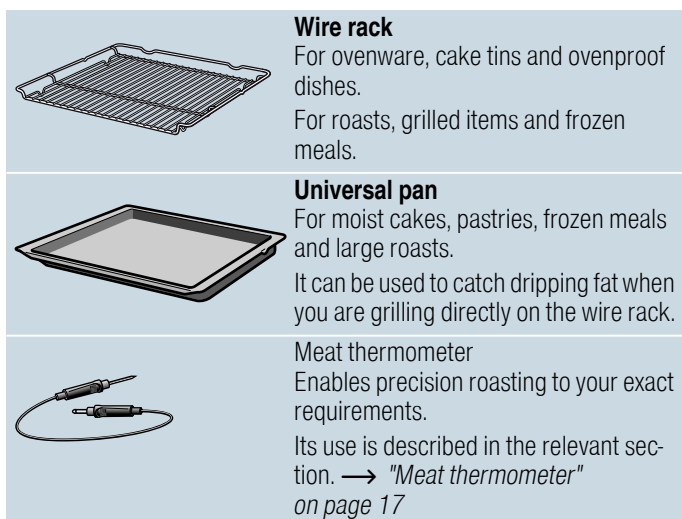

Only use original accessories. They are specially adapted for your appliance.

You can buy accessories from the after-sales service, from specialist retailers or online.

**Note:** The accessories may deform when they become hot. This does not affect their function. Once they have cooled down again, they regain their original shape.

### Inserting accessories

The cooking compartment has five shelf positions. The shelf positions are counted from the bottom up.

In some appliances, the highest shelf position is marked on the cooking compartment with the grill symbol.

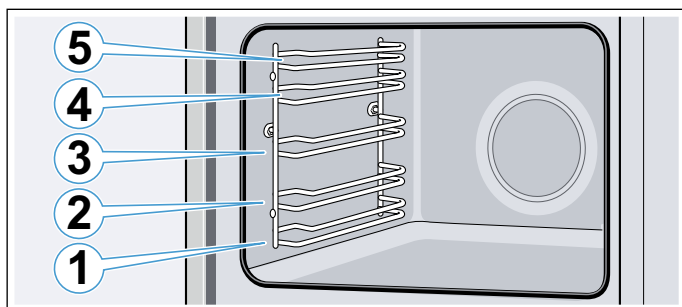

Always insert the accessory between the two guide bars for a shelf position.

Accessories can be pulled out approximately halfway without tipping.

### Notes

- Make sure that you always insert the accessories into the cooking compartment the right way round.
- Always insert accessories fully into the cooking compartment so that they do not touch the appliance door.
- Take any accessories that you will not be using out of the cooking compartment.

### Locking function

The accessories can be pulled out approximately halfway until they lock in place. The locking function prevents the accessories from tilting when they are pulled out. The accessories must be inserted into the cooking compartment correctly for the tilt protection to work properly.

When inserting the wire rack, ensure that lug **a** is at the rear and is facing downwards. The open side must be facing the appliance door and the outer rail must be facing downwards.

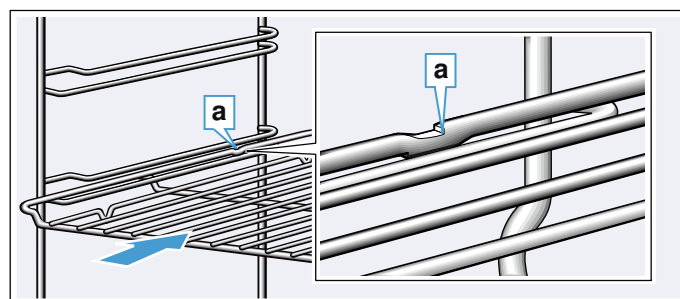

When inserting baking trays, make sure that the recess **a** is at the rear and is facing downwards. The sloping edge of the accessory **b** must be facing towards the appliance door.

Example in the picture: Universal pan

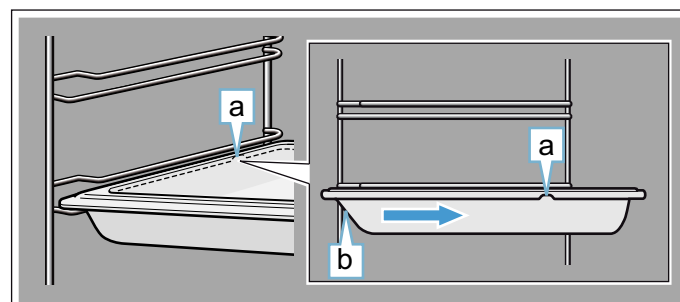

### Combining accessories

You can insert the wire rack and the universal pan at the same time to catch drops of liquid.

When inserting the wire rack, ensure that both spacers **a** are at the rear edge. When inserting the universal pan, the wire rack is on top of the upper guide rod of the shelf position.

en Before using for the first time

Example in the picture: Universal pan

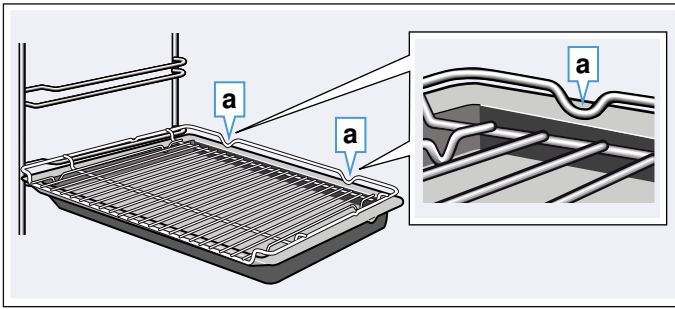

## Optional accessories

You can buy optional accessories from the after-sales service, from specialist retailers or online. \*You will find a comprehensive range of products for your appliance in our brochures and online.

Both availability and whether it is possible to order online differ between countries. Please see your sales brochures for more details.

**Note:** Not all optional accessories are suitable for every appliance. When purchasing, please always quote the exact identification number (E-no.) of your appliance. → "Customer service" on page 28

| Optional accessories  |
|---|
| <b>Wire rack</b><br>For ovenware, cake tins and ovenproof dishes, and for roasts and grilled food.  |
| <b>Universal pan, Self-cleaning</b><br>For moist cakes, pastries, frozen meals and large roasts. It can be used to catch dripping fat when you are grilling directly on the wire rack.    |
| <b>Baking tray, Self-cleaning</b><br>For tray bakes and small baked products.   |
| <b>Wire insert</b><br>For meat, poultry and fish.<br>For inserting into the universal pan to catch dripping fat and meat juices.  |
| <b>Profi pan</b><br>For preparing large quantities.   |
| <b>Lid for the Profi pan</b><br>The lid turns the Profi pan into a Profi roasting dish.   |
| <b>Pizza tray</b><br>For pizzas and large round cakes.  |
| <b>Grill tray, Self-cleaning</b><br>Use for grilling in place of the wire rack or as a splatter guard. Only use in the universal pan.   |
| <b>Bread-baking stone, Self-cleaning</b><br>For home-made bread, bread rolls and pizzas that require a crispy base.<br>The baking stone must be preheated to the recommended temperature. |
| <b>Glass roasting dish</b><br>For stews and bakes.<br>Particularly suitable for the "Meals" operating mode.   |

|  |
|--|
| <b>Glass tray</b><br>For large roasts, moist cakes and bakes.  |
| <b>Glass tray</b><br>For bakes, vegetable dishes and baked goods.  |
| <b>Pull-out system, 1 level, Self-cleaning</b><br>The pull-out rails at level 2 allow you to pull the accessories out further without them tipping.            |
| <b>Pull-out system, 2 levels, Self-cleaning</b><br>The pull-out rails at levels 2 and 3 allow you to pull the accessories out further without them tipping.    |
| <b>Pull-out system, 3 levels, Self-cleaning</b><br>The pull-out rails at levels 1, 2 and 3 allow you to pull the accessories out further without them tipping. |
| <b>Decorative trims</b><br>For concealing the lower shelf of the unit and the base of the appliance.   |

## Before using for the first time

Before you can use your new appliance, you must make some settings. You must also clean the cooking compartment and accessories.

### Initial use

After connecting the appliance to the power or following a power cut, the settings for initial use are shown in the display.

**Note:** You can change these settings at any time in the basic settings. → "Basic settings" on page 16

### Setting the language

German is the preset language.

1. Use the rotary selector to select the required language.
2. Touch the √ arrow.  
The next setting appears.

### Setting the clock

The time starts at 12:00.

1. Use the rotary selector to set the current time.
2. Touch the √ arrow

### Setting the date

The default date is 1.1.2014.

1. Always touch the √ arrow to move to the next setting.
2. Use the rotary selector to set the current day, month and year.



## With HomeConnect

1. Touch "Set using the assistant".
2. Further instructions can be found in section → "Home Connect" on page 20

## Cleaning the cooking compartment and accessories

Before using the appliance to prepare food for the first time, you must clean the cooking compartment and accessories.

### Cleaning the cooking compartment

To remove the new-appliance smell, heat up the cooking compartment when empty and with the oven door closed.

Make sure that there is no leftover packaging, such as polystyrene pellets, in the cooking compartment and remove the adhesive tape that is in or on the appliance. Before heating the appliance, wipe the smooth surfaces in the cooking compartment with a soft, wet cloth. Keep the kitchen ventilated while the appliance is heating.

Apply the settings indicated.

| Settings        |   |
|-----------------|---|
| Type of heating | 4D Hotair  |
| Temperature     | maximum   |
| Cooking time    | 1 hour  |

You can find out how to set the type of heating and the temperature in the next section.

Switch off the appliance after the cooking time indicated using the On/Off button.

After the cooking compartment has cooled down, clean the smooth surfaces with soapy water and a dish cloth.

### Cleaning the accessories

Clean the accessories thoroughly using soapy water and a dish cloth or soft brush.



## Operating the appliance

You have already learnt about the controls and how they work. Now we will explain how to set your appliance. You will learn about what happens when you switch the appliance on and off, and how to select the operating mode.

### Switching the appliance on and off

Before you are able to set the appliance, you must switch it on.

Exception: The childproof lock and the timer can be set when the appliance is switched off.

Displays or information, e.g the residual heat indicator in the cooking compartment, remain visible in the display after the appliance has been switched off.

Switch off your appliance when you do not need to use it. If no settings are applied for a long time, the appliance switches itself off automatically.

### Switching the appliance on

Use the On/Off button to switch the appliance on. The on/off symbol above the button is illuminated in blue.

The Siemens logo appears in the display, and then a type of heating and a temperature.

**Note:** You can specify which operating modes should appear after the appliance is switched on in the basic settings.

### Switching off the appliance

Use the On/Off button to switch off the appliance. The lighting above the button goes out.

A set function is cancelled.

The time appears in the display.

**Note:** You can set whether or not the time should be displayed when the appliance is switched off in the basic settings.

### Starting or interrupting operation

To start operation or to interrupt an operation which has started running, press the Start/Stop button. The cooling fan may continue to run after an operation is interrupted.

Press the On/Off button to delete all settings.

If you open the cooking compartment door during operation, operation is interrupted. Close the cooking compartment door to resume operation.

**Tip:** You can change this setting in the basic settings. → "Basic settings" on page 16

### Selecting an operating mode

When you select an operating mode, the appliance must be switched on.

1. Press the menu button.  
The operating modes menu opens.
2. Touch the required operating mode.  
Depending on the operating mode, different options are available.
3. Use the rotary selector to change the selection.  
Depending on the selection, change further settings.
4. Use the start/stop button to start.  
The elapsed time appears in the display. The settings and progress line can be seen.

### Setting the type of heating and temperature

After the appliance is switched on, the set default type of heating appears with the temperature. You can start this setting immediately with the Start/Stop button. If you want to set another type of heating, proceed as follows.

For other settings, you can change the values as follows:

Example in the picture: Top/bottom heating at 180 °C.

1. Use the rotary selector to change the type of heating.

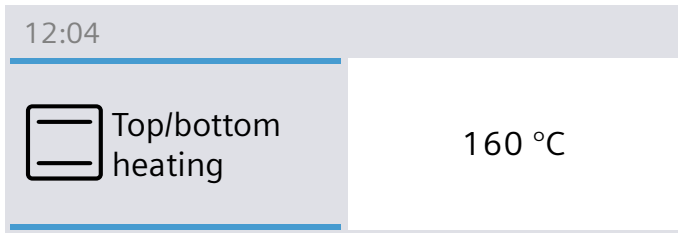

2. Touch the default temperature.
3. Use the rotary selector to change the temperature.

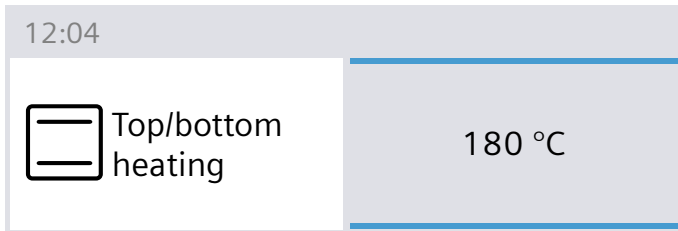

4. Press the Start/Stop button to start.

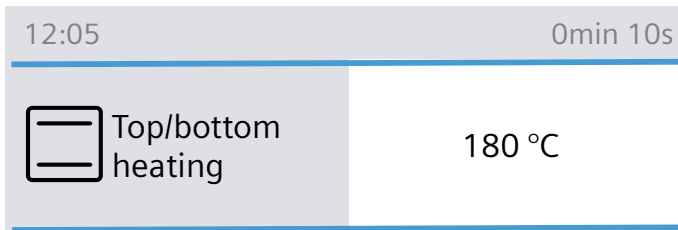

The set type of heating and the temperature are shown on the display.

### Rapid heat up

You can use the »»»» button to heat up the cooking compartment particularly quickly. The rapid heat up function is not possible for all types of heating.

Suitable types of heating:

|  |                    |
|--|--------------------|
|  | 4D hot air         |
|  | Top/bottom heating |
|  | Intensive heat     |

To ensure an even cooking result, do not place your food and the accessory in the cooking compartment until rapid heating is complete.

### Applying settings

Ensure you have selected a suitable type of heating. The temperature must be set to above 100 °C, otherwise the rapid heating function cannot be started.

1. Set the type of heating and temperature.
2. Press the »»»» button.

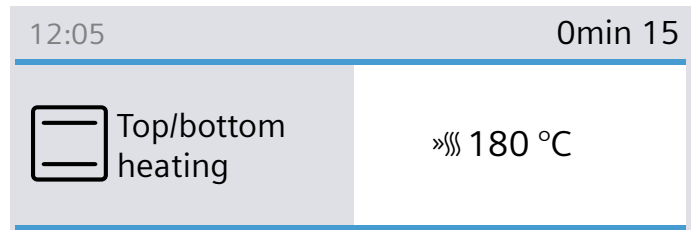

The »»»» symbol appears on the left next to the temperature. The temperature indicator starts to fill in.

When rapid heating is complete, an audible signal sounds. The »»»» symbol goes out. Place your dish in the cooking compartment.

### Notes

- If a cooking time has been set, this runs independently of rapid heating and counts down immediately when the operation is started.
- You can use the button to check the current cooking compartment temperature during rapid heating.

### Cancelling

Press the »»»» button. The »»»» symbol disappears from the display.

## Time-setting options

Your appliance has different time-setting options.

| Time-setting option | Use  |
|---------------------|--|
| Timer               | The timer functions like an egg timer. An audible signal sounds once the set time has elapsed.                               |
| Cooking time        | A signal sounds once a set cooking time has elapsed. The appliance switches off automatically.                               |
| End time            | Set a cooking time and an end time. The appliance switches off automatically so that the operation ends at the desired time. |



### Notes

- A cooking time of up to one hour can be set exactly to the minute. A cooking time over one hour can be set in five-minute increments.
- Depending on which direction you turn the rotary selector, the cooking time starts at a default value: Anti-clockwise, 10 minutes, Clockwise, 30 minutes.
- After a time-setting option has elapsed, a signal sounds and "Finished" appears in the status bar.
- Using the button, you can request information during the operation, which then appears briefly in the display.

## Timer

You can set the timer at any time, even if the appliance is switched off. It runs parallel to the other time settings and has a separate audible signal. In this way, you can tell whether it is the timer or a cooking time which has elapsed.



The maximum setting you can apply is 24 hours.

1. Press the  button.  
The field for the timer opens.
  2. Use the rotary selector to set the timer duration.  
The timer starts after a few seconds.
- The  symbol for the timer and the time counting down are displayed on the left in the status bar.



### When the time has elapsed

An audible signal sounds. "Timer elapsed" appears in the display. Use the  button to cancel the audible signal early.

### Cancelling the timer duration

Press the  button to open the time-setting options menu and turn the time back. Press the  button to close the menu.

### Changing the timer duration

Use the  button to open the time-setting options menu and change the timer time in the next few seconds using the rotary selector. Start the timer with the  button.

## Cooking time

If you set the cooking time for your meal, the operation stops automatically once this time has elapsed. The oven stops heating.  
The maximum setting you can apply is 23 hours and 59 minutes.

Prerequisite: A type of heating and a temperature have been set.

For example: Setting for 4D hot air, 180 °C, cooking time 45 minutes.

1. Press the  button.  
The time-setting options menu opens.

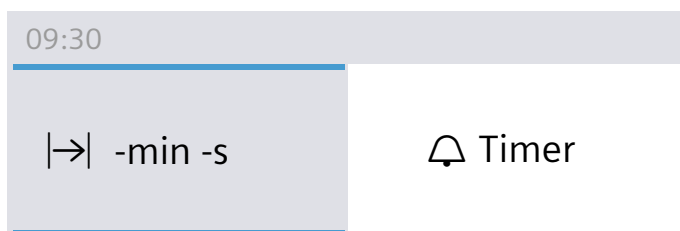

2. Set the cooking time using the rotary selector.

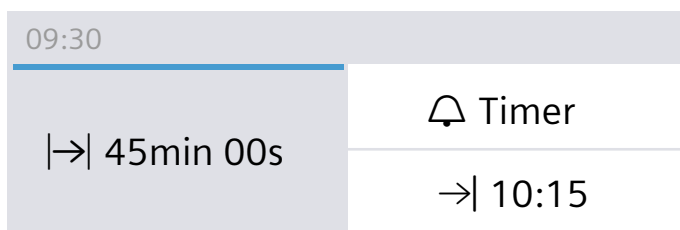

3. Press the Start/Stop button to start.  
You can see the  cooking time counting down in the status bar.

### The cooking time has elapsed

A signal sounds. The oven stops heating. "Finished" appears in the status bar. You can cancel the audible signal early using the  button.

### Cancelling the cooking time

Press the  button to open the time-setting options menu. Turn the time back. The type of heating and temperature set are shown in the display.

### Changing the cooking time

Press the  button to open the time-setting options menu. Change the cooking time using the rotary selector.

## End time

If you change the end time, please remember that easily spoiled foods must not be allowed to remain in the cooking compartment for too long.

Prerequisite: The selected operation has not already begun. A cooking time has been set. The time-setting options menu  is open.

Example in the picture: You put the dish in the cooking compartment at 9:30. It takes 45 minutes to cook and will be ready at 10:15, but you would like it to be ready at 12:45 instead.

1. Touch the "End " field.  
The end time is displayed.

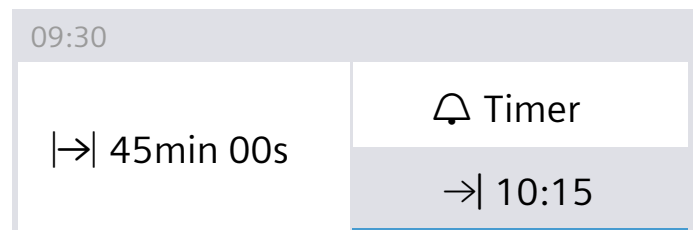

2. Using the rotary selector, set a later end time.

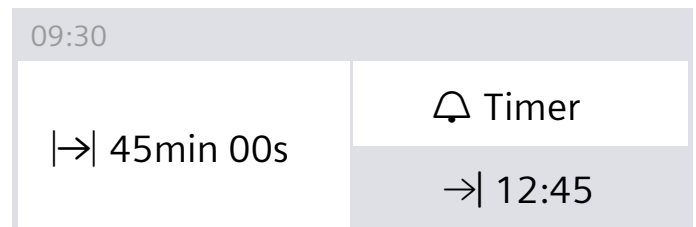

3. Confirm with the Start/Stop button.

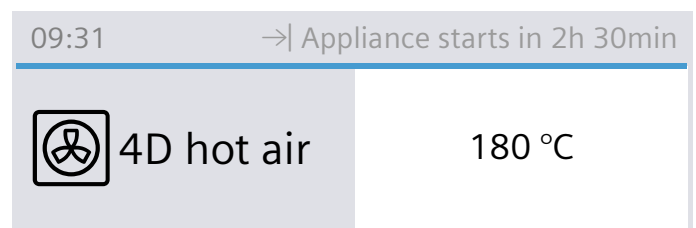



The oven is on standby. The operation starts at the appropriate time. You can see the cooking time counting down in the status bar.

### The cooking time has elapsed

A signal sounds. The oven stops heating. "Finished" appears in the status bar. You can cancel the audible signal early using the  button.

### Correcting the end time

This is possible if the oven is in standby. Use the  button to open the time-setting options menu, touch "End →|" and use the rotary selector to correct the end time. Press the  button to close the menu.

### Cancelling the end time



This is possible if the oven is on standby. To do so, open the time-setting options menu using the  button. Touch "End →|" and reset the End time using the rotary selector. The cooking time immediately starts to count down.

## Childproof lock

Your appliance is equipped with a childproof lock so that children cannot switch it on accidentally or change any settings.

### Activating and deactivating

You can activate and deactivate the childproof lock when the appliance is switched on or off.

In each case, press the  button for approx. 4 seconds. A confirmation note appears in the display and the  symbol appears in the status bar.

### The appliance door is locked

In the basic settings, you can change the settings so that the appliance door is also locked in addition to the control panel.

The appliance door locks if the temperature in the cooking compartment reaches approx. 50 °C. The  symbol is displayed in the status bar. When the oven is switched off, the appliance door locks immediately if the childproof lock has been activated.

## Basic settings

There are various settings available to you in order to help use your appliance effectively and simply. You can change these settings as required.

### Changing settings

1. Press the menu button.  
The operating modes menu opens.
2. Select the "Settings" operating mode.  
The first basic setting appears.
3. Use the rotary selector to change the values.
4. Touch the  arrow to switch to the next basic settings.
5. Press the menu button to save.  
"Save" or "Discard" appears on the display.

### List of settings

This list tells you all the basic settings and how to change them. Depending on the model of the appliance you own, the display will show only those settings that apply to your appliance.

You can change the following settings:

| Setting                      | Options   |
|------------------------------|---|
| Select language              | Additional languages possible   |
| Time of day                  | Sets the current time   |
| Date                         | Sets the current date   |
| Audible signal duration      | Short (30 s)  |
|                              | Medium (1 m)  |
|                              | Long (5 m)  |
| Button tone                  | Switched off (button tone still sounds when switching on/off using the "On/off" button) |
|                              | Switched on   |
| Volume                       | Can be adjusted to one of five different levels   |
| Display brightness           | Can be adjusted to one of five different levels   |
| Clock display                | Digital with date   |
|                              | Analogue  |
|                              | Off   |
| Lighting                     | On during operation   |
|                              | Off during operation  |
| Childproof lock              | Door lock + button lock   |
|                              | Button lock only  |
| Operation after switching on | Main menu   |
|                              | Heating modes   |
|                              | Dishes*   |
| Night-time dimming           | Switched off  |
|                              | Switched on (display dimmed between 10 p.m. and 5.59 a.m.)                              |



|   |  |
|---|--|
| Brand name logo                           | Display  |
|   | Do not display                                       |
| Fan run-on time                           | Recommended  |
|   | Minimum  |
| Pull-out system                           | Not retrofitted                                      |
|   | Retrofitted  |
| Sabbath mode                              | Switched on  |
|   | Switched off   |
| Home Connect                              | Switches Wi-Fi on or off → "Home Connect" on page 20 |
| Factory settings                          | Restore  |
|   | Do not restore                                       |
| *) Included, depending on appliance model |  |

### Caution!

For shelves and single rails: "Not retrofitted" setting.  
For sets of two or three rails: "Retrofitted" setting.

**Note:** Changes to the language, button tone and display brightness settings take effect immediately. All other changes take effect after the settings have been saved.

### Changing the time

You can change the time in the basic settings.  
For example: Changing from summer to winter time.

1. Press the menu button.  
The operating modes menu opens.
2. Touch "Settings".
3. Touch the arrow  to move to "Clock".
4. Use the rotary selector to change the time.
5. Press the menu button.  
"Save" or "Discard" appears on the display.

### Power cut

Following a long power cut, the settings for initial use are shown in the display.

Reset the language, time and date.

## Meat thermometer

The meat thermometer Plus makes precise cooking possible. It measures the temperature inside the food. Once the set temperature has been reached, the appliance automatically switches itself off.

### Types of heating

Once you have placed the meat thermometer in the cooking compartment, the following heating modes are available for you to select.

|   |                         |
|---|-------------------------|
|  | 4D hot air              |
|  | Hot air eco             |
|  | Top/bottom heating      |
|  | Top/bottom heating eco  |
|  | Pizza setting           |
|  | Circulated air grilling |
|  | Intensive heat          |

### Notes

- The meat thermometer measures the temperature on the inside of the food between 30 °C and 99 °C.
- Use only the meat thermometer supplied. You can purchase it as a spare part from the after-sales service.
- After use, always remove the meat thermometer from the cooking compartment. Never store it inside the cooking compartment.

### Cooking compartment temperature

To prevent damage to the meat thermometer, do not set temperatures higher than 250 °C.

The interior temperature set in the cooking compartment must be at least 10 °C higher than the core temperature that has been set.

### Inserting the meat probe into the food

Before placing your food into the cooking compartment, insert the meat probe into the food.

The meat probe has three measuring points. Ensure that the middle measuring point is inserted in the food.

**Meat:** For large pieces of meat, insert the meat probe at an angle from above as far as it will go into the meat. For relatively thin pieces of meat, insert the meat probe from the side at the thickest point.

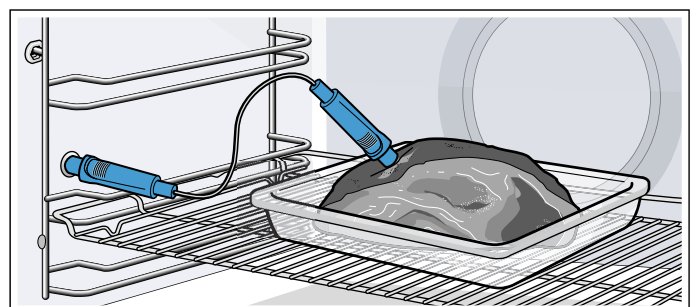

**Poultry:** Insert the meat probe as far as it will go into the thickest point in the breast. Insert the meat probe into the poultry crossways or lengthways depending on its structure. Then turn the poultry and place it on the wire rack breast-side down.

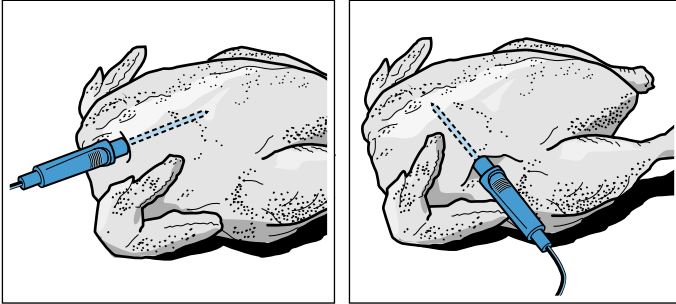

**Fish:** Insert the meat probe behind the head as far as it will go towards the spine. Place the whole fish onto the wire rack and prop it up in the swimming position using half a potato.

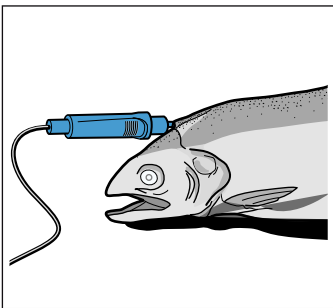

**Turning the food:** If you wish to turn the food, do not remove the meat probe. Once you have turned the food, check that the meat probe is correctly positioned in the food.

If you remove the meat probe while the food is cooking, all settings will be reset and you will have to apply them again.

**Caution!**

Ensure that the meat probe's cable does not become trapped.

To prevent the meat probe from being damaged by excessive heat, there must be a gap of a few centimetres between the grill element and the meat probe. The meat may expand during the cooking process.

**Setting the core temperature**

1. Insert the meat thermometer in the socket on the left-hand side of the cooking compartment.
2. Use the rotary selector to select the type of heating or the "Dishes" operating mode.
3. Touch the default temperature and set the temperature using the rotary selector.
4. Touch the "Core temperature" field and set the core temperature using the rotary selector.
5. Press the Start/Stop button to start. The operation begins.

**Once the set core temperature in the food has been reached**

An audible signal sounds. The oven stops heating. You can unplug the meat thermometer from the socket. The  symbol goes out.

**Changing the core temperature**

You can change the core temperature at any time.

**Cancelling**

Unplug the meat thermometer from the socket.

**⚠ Warning – Risk of burns!**

The cooking interior and the core temperature probe become very hot. Use oven mitts to plug and unplug the core temperature probe.

**⚠ Warning – Risk of electric shock!**

The insulation of an incompatible meat probe may be damaged. Only use the meat probe which is recommended for this appliance.

**Core temperatures of different foods**

Do not use frozen food. The figures in the table are given as a guide. They depend on the quality and composition of the food.

You can find comprehensive information on the heating mode and temperature at the end of the instruction manual. → "Tested for you in our cooking studio" on page 30

| Food                               | Core temperature in °C |
|------------------------------------|------------------------|
| <b>Poultry</b>                     |                        |
| Chicken                            | 80-85                  |
| Chicken breast                     | 75-80                  |
| Duck                               | 80-85                  |
| Duck breast, medium rare           | 55-60                  |
| Turkey                             | 80-85                  |
| Turkey breast                      | 80-85                  |
| Goose                              | 80-90                  |
| <b>Pork</b>                        |                        |
| Shoulder of pork                   | 85-90                  |
| Fillet of pork, medium rare        | 62-70                  |
| Loin of pork, well done            | 72-80                  |
| <b>Beef</b>                        |                        |
| Tenderloin or sirloin, rare        | 45-52                  |
| Tenderloin or sirloin, medium rare | 55-62                  |
| Tenderloin or sirloin, well done   | 65-75                  |
| <b>Veal</b>                        |                        |
| Joint of veal or shoulder, lean    | 75-80                  |
| Joint of veal, shoulder            | 75-80                  |
| Knuckle of veal                    | 85-90                  |

| Food                        | Core temperature in °C |
|-----------------------------|------------------------|
| <b>Lamb</b>                 |                        |
| Leg of lamb, medium rare    | 60-65                  |
| Leg of lamb, well done      | 70-80                  |
| Saddle of lamb, medium rare | 55-60                  |
| <b>Fish</b>                 |                        |
| Whole fish                  | 65-70                  |
| Fish fillet                 | 60-65                  |
| <b>Miscellaneous</b>        |                        |
| Meat loaf, all kinds        | 80-90                  |

## Sabbath mode

With the Sabbath mode, a cooking time of up to 74 hours can be set. You can keep the food in the cooking compartment warm without having to switch the oven on or off.

### Starting Sabbath mode

Prerequisite: "Sabbath mode activated" is activated in the basic settings. → *"Basic settings" on page 16*

The cooking compartment heats up with top/bottom heating and a temperature between 85 °C and 140 °C.

1. Press the On/Off button.  
A type of heating and a temperature are suggested in the display.
2. Turn the rotary selector anti-clockwise and select the "Sabbath mode" type of heating.
3. Touch the suggested temperature and set the temperature using the rotary selector.
4. Press the  button to open the time-setting options menu and touch the "Cooking time" field.  
25:00 hours are suggested.
5. Use the rotary selector to set the required cooking time.
6. Press the Start/Stop button to start.  
You can see the cooking time counting down in the status bar.

### The cooking time has elapsed

A signal sounds. The oven stops heating. "Finished" appears in the status bar.

### Setting a later end time

It is not possible to set a later end time.

### Cancelling Sabbath mode

Press the On/Off button. All settings are deleted. You can apply new settings.

## Cleaning function

Use "Self-cleaning" mode to clean the cooking compartment.

You can choose from three cleaning settings.

| Setting | Cleaning level | Duration                   |
|---------|----------------|----------------------------|
| 1       | Light          | Approx. 1 hour, 15 minutes |
| 2       | Medium         | Approx. 1 hour, 30 minutes |
| 3       | Intensive      | Approx. 2 hours            |

The dirtier the cooking compartment and the longer the dirt has been there, the higher the cleaning setting should be. A cleaning cycle requires only approx. 2.5 – 4.7 kilowatt hours.

**Note:** For your safety, the cooking compartment door locks automatically. It cannot be opened again until the  symbol for the locking mechanism goes out in the status bar. The interior lighting remains off during cleaning.

### Warning

#### Risk of burns!

- The cooking compartment becomes extremely hot during the cleaning function. Never open the appliance door. Allow the appliance to cool down. Keep children away from the appliance.
-  The appliance becomes very hot on the outside during the cleaning function. Never touch the appliance door. Allow the appliance to cool down. Keep children at a safe distance.

### Warning

#### Risk of harm to health!

The cleaning function heats up the cooking compartment to a very high temperature so that food remnants left over from roasting, grilling and baking will burn off. This process releases vapours, which can irritate the mucous membranes. While the cleaning function is running, keep the kitchen well ventilated. Do not remain in the room for long periods. Keep children and pets away. Follow the instructions even when using the Delayed start function with a delayed end time.

### Before running the cleaning function

While cleaning is in progress, you can clean an accessory at the same time, e.g. the universal pan or the baking tray. Before starting the cleaning function, remove the worst of the food remnants manually. Slide the accessory in at level 2.

Clean the appliance door and along the edges of the cooking compartment in the area around the seal. Do not scrub or remove the seal.

Clean the inner door panel using hot soapy water and a dish cloth. Dry with a soft cloth. If the cooking compartment is heavily soiled, use oven cleaner.

**Note:** You can clean the enamelled accessory supplied in the cooking compartment when the cleaning function is cleaning the cooking compartment. You cannot clean any of the wire racks when using the cleaning function.

The wire racks are not suitable for the cleaning function and will become discoloured. Further accessories that can be cleaned using the cleaning function are listed in the table for special accessories. → "Accessories" on page 11

### **Warning** **Risk of fire!**

- Loose food residues, grease and meat juices may catch fire during the cleaning function. Before starting the cleaning function, remove coarse dirt from the cooking compartment and from the accessories.
- The appliance will become very hot on the outside during the cleaning function. Never hang combustible objects, e.g. tea towels, on the door handle. Do not place anything against the front of the appliance. Keep children away from the appliance.
- If the door seal is damaged, a large amount of heat will be generated around the door. Do not scrub or remove the seal. Never operate the appliance if the seal is damaged or missing.



### **Warning – Risk of serious damage to health!**

The appliance will become very hot during the cleaning function. The non-stick coating on baking trays and tins is destroyed and noxious gases are released. Never clean non-stick baking trays and baking tins using the cleaning function. Only clean enamelled accessories using the cleaning function.

## Setting the self-cleaning function

1. Press the menu button.  
The operating modes menu opens.
2. Select the "Self-cleaning" operating mode.  
Cleaning setting 3 is suggested. You can start the cleaning process immediately using the "Start/stop" button or
3. select a different cleaning setting using the rotary selector.
4. Press the "Start/stop" button to start the cleaning operation.

Ventilate the kitchen when the cleaning function is running.

The cooking compartment door locks shortly after operation starts. The  symbol for the locking mechanism appears on the right-hand side of the status bar next to the elapsing duration. The cooking compartment door cannot be opened until the  symbol goes out in the status bar.

### Once the cleaning has finished

An audible signal sounds. The oven stops heating. "Finished" appears in the status bar. Use the  button to switch off the audible signal.

### Cancelling the cleaning operation

Use the "On/off" button to switch off the oven. The cooking compartment door cannot be opened until the  symbol goes out in the status bar.

## Adjusting the cleaning setting

Once cleaning starts, the cleaning setting can no longer be changed.

### You can set the cleaning to run overnight

In the section "Time settings", you can find out how to delay the end time. This allows you to use the oven at any time throughout the day. → "Time-setting options" on page 14

## Once the cleaning function has ended

Once the cooking compartment has cooled down, use a damp cloth to wipe off the ash that has been left behind in the cooking compartment and around the appliance door.

**Note:** Very bad soiling may cause white deposits to remain on the enamel surfaces. This is residue from the food and is harmless. It does not affect performance. You can remove these residues using lemon juice if required.

## Home Connect

This appliance is Wi-Fi-capable and can be remotely controlled using a mobile device.

If the appliance is not connected to the home network, the appliance functions in the same way as an oven with no network connection and can still be operated via the display.

The availability of the Home Connect function depends on the availability of Home Connect services in your country. Home Connect services are not available in every country. You can find more information on this at [www.home-connect.com](http://www.home-connect.com).

### Notes

- Ensure that you follow the safety instructions in this instruction manual and that you comply with these even when you are away from home and are operating the appliance via the Home Connect app. You must also follow the instructions in the Home Connect app. → "Important safety information" on page 5
- Operating the appliance directly from the appliance always has priority. During this time, it is not possible to operate the appliance using the Home Connect app.

## Setting up

To set up Home Connect for your appliance, you require the following:

- Your appliance, which must be connected to the mains and switched on,
- A smartphone or tablet with the latest version of the iOS or Android operating system,
- The Home Connect app,
- The supplied Home Connect installation instructions,



- And your appliance within range of the Wi-Fi signal for your home network

The app guides you through the entire process. Follow the instructions in the app.

## Remote Start

In order to start and operate your appliance via the Home Connect app, you must activate remote start. If remote start has been deactivated, you can only display the operating statuses in the Home Connect app and implement appliance settings.

**Note:** Some of the operating modes can only be started on the oven.

Remote start is automatically deactivated:

- if you open the oven door 15 minutes after remote start has been activated.
- if you open the oven door 15 minutes after the end of operation.

| Basic setting   | Possible settings  | Explanation   |
|---|--|---|
| WiFi  | Switching on/off   | You can switch the wireless module on and off. If WiFi is activated, you can use the Home Connect function. The appliance requires max. 2 W in networked standby.   |
| Network   | Connecting to the network/<br>disconnecting from the network | Switch the network connection on or off as required (e.g. for holiday).<br>The network information will be retained after the appliance is switched off. After switching on the appliance, wait for a few seconds while it reconnects to the network. |
| Connect to app  |  | Start the connection process between the app and the appliance.   |
| Remote control  | on/off   | Use the Home Connect app to access the appliance's functions. When it is deactivated, only the operating statuses are displayed in the app.   |
| Appliance information  |  | The display shows the network and appliance information.  |

## Remote diagnostics

If a fault occurs, the after-sales service can use remote diagnostics to access your appliance.

Contact the after-sales service, making sure that your appliance is connected to the Home Connect server and checking that the remote diagnostics service is available in your country.

**Note:** For more information and to check whether the remote diagnostics service is available in your country, please visit the Help & Support area of the Home Connect website for your country: [www.home-connect.com](http://www.home-connect.com)

## About data protection

When your appliance is connected for the first time to a WLAN network, which is connected to the Internet, your appliance transmits the following categories of data to the Home Connect server (initial registration):

- Unique appliance identification (consisting of appliance codes as well as the MAC address of the installed WiFi communication module).
- Security certificate of the WiFi communication module (to ensure a secure IT connection).
- The current software and hardware version of your domestic appliance.
- Status of any previous resetting to factory settings.

When you start the oven using the controls on the appliance itself, remote start is automatically activated. You can now make changes or start a new programme from your mobile device.

## Activating remote start

1. Press the menu button.
2. Touch "Remote start".  
 appears in the display.

## Home Connect settings

You can adjust Home Connect to suit your requirements at any time.

**Note:** You will find the Home Connect settings in your appliance's basic settings. Which settings the display shows will depend on whether Home Connect has been set up and whether the appliance is connected to your home network.

This initial registration prepares the Home Connect functions for use and is only required when you want to use these Home Connect functions for the first time.

**Note:** Ensure that the Home Connect functions can be used only in conjunction with the Home Connect app. Information on data protection can be accessed in the Home Connect app.

## Declaration of Conformity

BSH Hausgeräte GmbH hereby declares that the appliance which features Home Connect is in accordance with the basic requirements and the other relevant provisions of the directive 2014/53/EU.

A detailed RED Declaration of Conformity can be found online at [www.siemens-home.bsh-group.com](http://www.siemens-home.bsh-group.com) on the product page of your appliance with the additional documents.



2.4 GHz band: max. 100 mW  
5 GHz band: max. 100 mW

|   |    |    |    |    |    |    |    |    |
|---|----|----|----|----|----|----|----|----|
|   | BE | BG | CZ | DK | DE | EE | IE | EL |
|  | ES | FR | HR | IT | CY | LV | LT | LU |
|   | HU | MT | NL | AT | PL | PT | RO | SI |
|   | SK | FI | SE | UK | NO | CH | TR |    |

5 GHz Wi-Fi: for indoor use only

## Cleaning

With good care and cleaning, your appliance will retain its appearance and remain fully functioning for a long time to come. We will explain here how you should correctly care for and clean your appliance.

### Suitable cleaning agents

To ensure that the different surfaces are not damaged by using the wrong cleaning agent, observe the information in the table. Depending on the appliance model, not all of the areas listed may be on/in your appliance.

#### Caution!

#### Risk of surface damage

Do not use:

- Harsh or abrasive cleaning agents,
- Cleaning agents with a high alcohol content,
- Hard scouring pads or cleaning sponges,
- High-pressure cleaners or steam cleaners,
- Special cleaners for cleaning the appliance while it is hot.

Wash new sponge cloths thoroughly before use.

**Tip:** Highly recommended cleaning and care products can be purchased through the after-sales service. Observe the respective manufacturer's instructions.

#### Warning – Risk of burns!

The appliance becomes very hot. Never touch the interior surfaces of the cooking compartment or the heating elements. Always allow the appliance to cool down. Keep children at a safe distance.

| Area                      | Cleaning   |
|---------------------------|--|
| <b>Appliance exterior</b> |  |
| Stainless steel front     | Hot soapy water:<br>Clean with a dish cloth and then dry with a soft cloth.<br><br>Remove flecks of limescale, grease, starch and albumin (e.g. egg white) immediately. Corrosion can form under such flecks.<br><br>Special stainless steel cleaning products suitable for hot surfaces are available from our after-sales service or from specialist retailers. Apply a very thin layer of the cleaning product with a soft cloth. |
| Plastic                   | Hot soapy water:<br>Clean with a dish cloth and then dry with a soft cloth.<br><br>Do not use glass cleaner or a glass scraper.  |

|                                       |  |
|---------------------------------------|--|
| Painted surfaces                      | Hot soapy water:<br>Clean with a dish cloth and then dry with a soft cloth.  |
| Control panel                         | Hot soapy water:<br>Clean with a dish cloth and then dry with a soft cloth.<br><br>Do not use glass cleaner or a glass scraper.  |
| Door panels                           | Hot soapy water:<br>Clean with a dish cloth and then dry with a soft cloth.<br><br>Do not use a glass scraper or a stainless steel scouring pad.   |
| Door handle                           | Hot soapy water:<br>Clean with a dish cloth and then dry with a soft cloth.<br><br>If descaler comes into contact with the door handle, wipe it off immediately. Otherwise, any stains will not be able to be removed.   |
| <b>Appliance interior</b>             |  |
| Enamelled surfaces                    | Hot soapy water or a vinegar solution:<br>Clean with a dish cloth and then dry with a soft cloth.<br><br>Soften baked-on food remnants with a damp cloth and soapy water. Use stainless steel wire wool or oven cleaner to remove stubborn dirt.<br><br><b>Caution!</b><br>Never use oven cleaner in the cooking compartment when it is still warm. This may damage the enamel. Remove all food remnants from the cooking compartment and the appliance door before you next heat up the appliance.<br><br>Leave the cooking compartment open to dry after cleaning it.<br><br>It is best to use the cleaning function.<br>→ "Cleaning function" on page 19<br><br><b>Note:</b> Food residues can cause white deposits to form. These are harmless and do not affect how the appliance works.<br>Remove using lemon juice if required. |
| Glass cover for the interior lighting | Hot soapy water:<br>Clean with a dish cloth and then dry with a soft cloth.<br><br>If the cooking compartment is heavily soiled, use oven cleaner.   |
| Door cover                            | made from stainless steel:<br>Use stainless steel cleaner. Follow the manufacturers' instructions. Do not use stainless steel care products.<br><br>made from plastic:<br>Clean using hot soapy water and a dish cloth. Dry with a soft cloth. Do not use glass cleaner or a glass scraper.<br><br>Remove the door cover for cleaning.   |
| Rails                                 | Hot soapy water:<br>Soak and clean with a dish cloth or brush.   |

|                  |  |
|------------------|--|
| Pull-out system  | Hot soapy water:<br>Clean with a dish cloth or a brush.<br>Do not remove the lubricant while the pull-out rails are pulled out – it is best to clean them when they are pushed in. Do not clean in the dishwasher. |
| Accessories      | Hot soapy water:<br>Soak and clean with a dish cloth or brush.<br>If there are heavy deposits of dirt, use a stainless steel scouring pad.   |
| Meat thermometer | Hot soapy water:<br>Clean with a dish cloth or a brush.<br>Do not clean in the dishwasher.   |

**Notes**

- Slight differences in colour on the front of the appliance are caused by the use of different materials, such as glass, plastic and metal.
- Shadows on the door panels, which look like streaks, are caused by reflections made by the interior lighting.
- Enamel is baked on at very high temperatures. This can cause some slight colour variation. This is normal and does not affect operation. The edges of thin trays cannot be completely enamelled. As a result, these edges can be rough. This does not impair the anti-corrosion protection.

**Keeping the appliance clean**

Always keep the appliance clean and remove dirt immediately so that stubborn deposits of dirt do not build up.

**⚠ Warning – Risk of fire!**

Loose food remnants, fat and meat juices may catch fire. Before using the appliance, remove the worst of the food remnants from the cooking compartment, heating elements and accessories.

**Tips**

- Clean the cooking compartment after each use. This will ensure that dirt cannot be baked on.
- Always remove flecks of limescale, grease, starch and albumin (e.g. egg white) immediately.
- Use the universal pan for baking very moist cakes.
- Use suitable ovenware for roasting, e.g. a roasting dish.

**Rails**

With good care and cleaning, your appliance will retain its appearance and remain fully functional for a long time to come. This will tell you how to remove the shelves and clean them.

**Detaching and refitting the rails**

**⚠ Warning – Risk of burns!**

The rails become very hot. Never touch the hot rails. Always allow the appliance to cool down. Keep children away from the appliance.

**Detaching the rails**

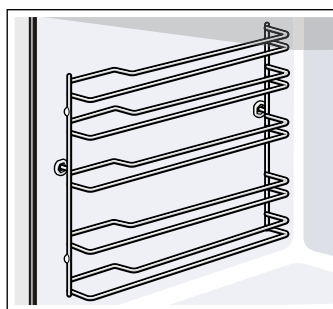

1. Lift the rail slightly at the front **a** and detach it **b** (figure **1**).
2. Then pull the whole rail towards you and take it out (figure **2**).

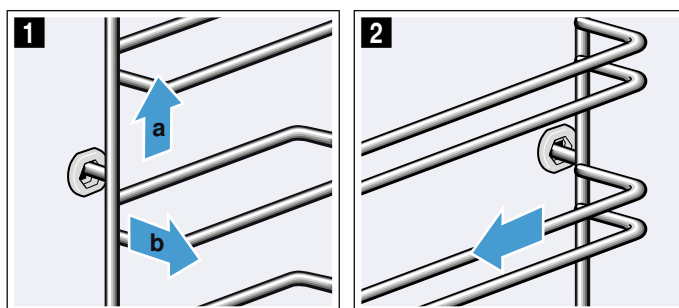

Clean the rails with cleaning agent and a sponge. For stubborn deposits of dirt, use a brush.

### Attaching the rails

The rails only fit on the right or the left side. For both rails, ensure that the curved rods are at the front.

1. First, insert the rail in the middle of the rear socket **a**, until the rail rests against the cooking compartment wall, and push it back **b** (figure **1**).
2. Then insert the rail into the front socket **c**, until the rail also rests against the cooking compartment wall here, and press it downwards **d** (figure **2**).

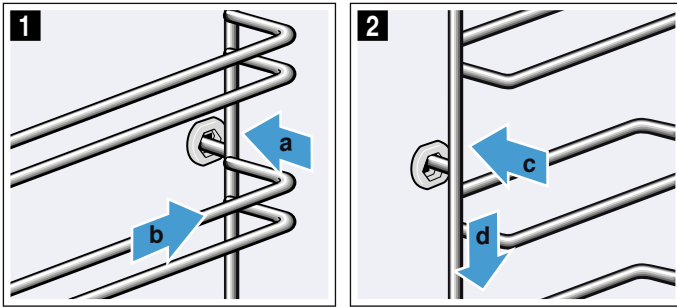

## Appliance door

With good care and cleaning, your appliance will retain its appearance and remain fully functional for a long time to come. This will tell you how to remove the appliance door and clean it.

### Removing and fitting the appliance door

For cleaning purposes and to remove the door panels, you can detach the appliance door.

The appliance door hinges each have a locking lever. When the locking levers are closed (figure **1**), the appliance door is secured in place. It cannot be detached.

When the locking levers are open in order to detach the appliance door (figure **2**), the hinges are locked. They cannot snap shut.

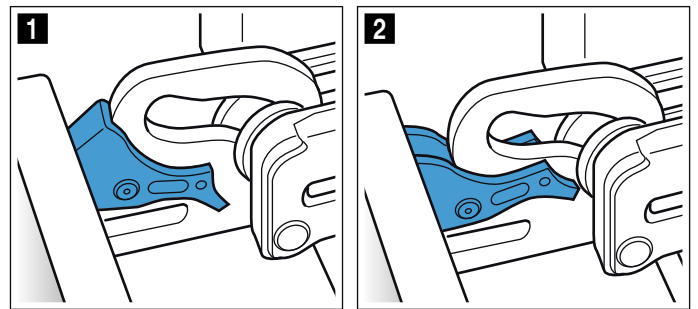

### Warning Risk of injury!

- If the hinges are not locked, they can snap shut with great force. Ensure that the locking levers are always fully closed or, when detaching the appliance door, fully open.
- The hinges on the appliance door move when opening and closing the door, and you may be trapped. Keep your hands away from the hinges.

### Removing the appliance door

1. Open the appliance door fully and push it in the direction of the appliance.
2. Fold up the two locking levers on the left and right (figure **1**).
3. Close the appliance door as far as it goes **a**. With both hands, grip the door on the left- and right-hand side and pull it up and out (figure **2**).

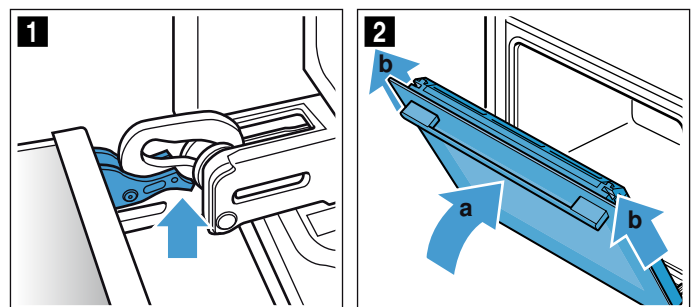



## Fitting the appliance door

Reattach the appliance door in the opposite sequence to removal.

1. When attaching the appliance door, ensure that both hinges are inserted straight into the opening (figure 1). Place both hinges at the bottom on the outer panel and use this as a guide. Ensure that the hinges are inserted into the correct opening. You must be able to insert them easily and without resistance. If you can feel any resistance, check that the hinges are inserted into the correct opening.

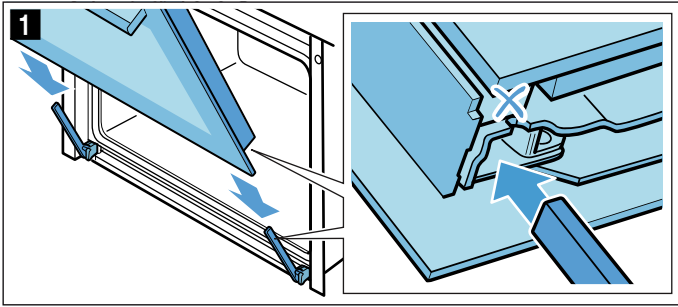

2. Open the appliance door fully. Fold both locking levers closed again (figure 2).

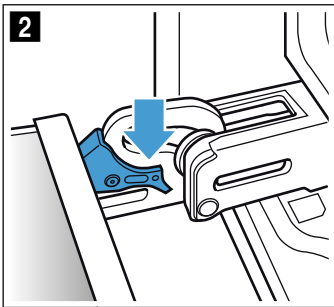

3. Close the cooking compartment door.

## Removing the door cover

The stainless steel inlay in the door cover may become discoloured. To carry out thorough cleaning, you can remove the cover. → "Cleaning" on page 22

1. Open the appliance door slightly.
2. Press on the right and left side of the cover (figure 1).
3. Remove the cover (figure 2). Close the appliance door carefully.

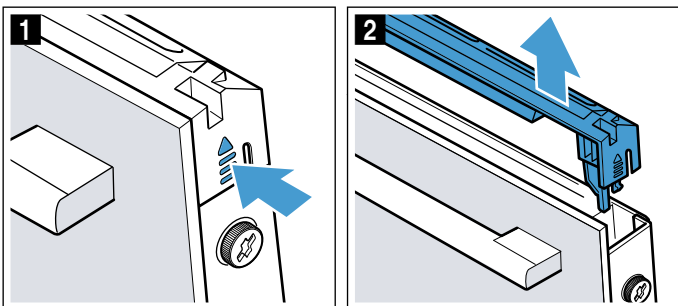

**Note:** Clean the stainless steel inlay in the cover with stainless steel cleaner. Clean the rest of the door cover with soapy water and a soft cloth.

4. Open the appliance door again slightly. Put the cover back in place and press on it until it clicks audibly into place (figure 3).

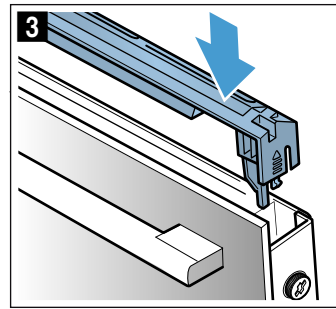

5. Close the appliance door.

## Removing and installing the door panels

To facilitate cleaning, you can remove the glass panels from the appliance door.

### Removing the door from the appliance

1. Open the appliance door slightly.
2. Press on the right and left side of the cover (figure 1).
3. Remove the cover (figure 2).

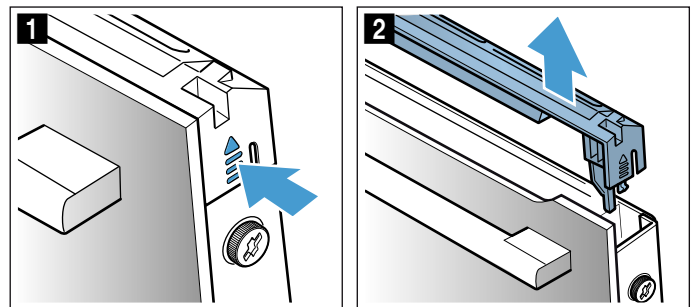

4. Loosen and remove the screws on the left and right of the appliance door (figure 3).
5. Before closing the door again, trap a tea towel which has been folded several times in the door (figure 4). Pull out the front panel upwards and lay it on a flat surface with the door handle facing downwards.

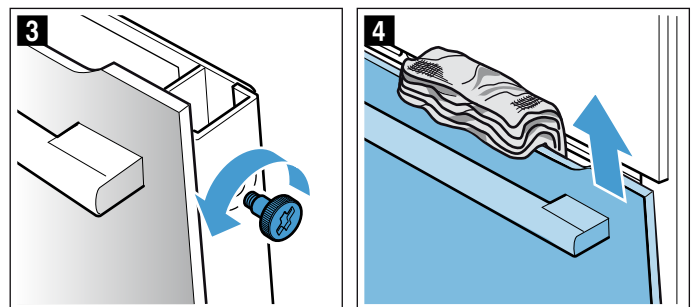

- Push both retainers on the intermediate panel upwards, but do not remove it (figure 5). Hold the panel with one hand. Remove the panel.

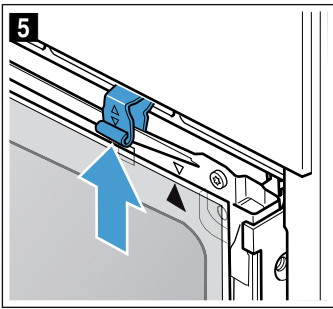

Clean the panels with glass cleaner and a soft cloth.

**Warning**  
**Risk of injury!**

- Scratched glass in the appliance door may develop into a crack. Do not use a glass scraper, sharp or abrasive cleaning aids or detergents.
- The hinges on the appliance door move when opening and closing the door, and you may be trapped. Keep your hands away from the hinges.

**Fitting the door on the appliance**

When fitting the intermediate panel, make sure that the arrow is in the top right of the panel and that it aligns with the arrow on the metal panel.

- Insert the intermediate panel at the bottom into the retainer and push it in firmly at the top (figure 1).
- Push both retainers downwards (figure 2).

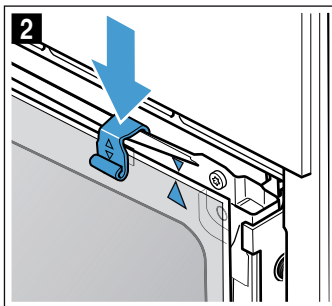
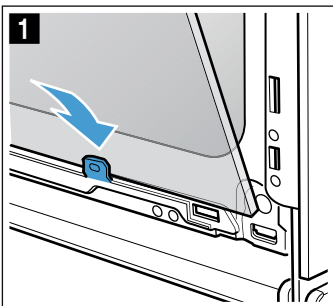

- Insert the front panel at the bottom into the retainers (figure 3).
- Close the front panel until both upper hooks are opposite the opening (figure 4).

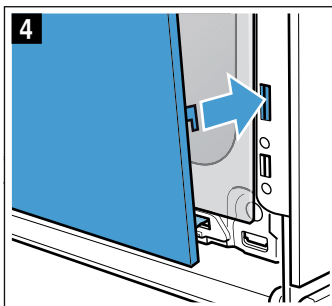
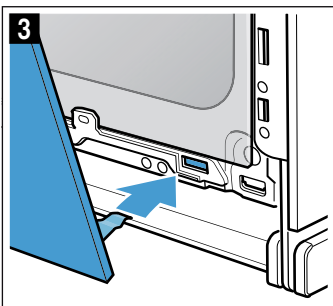

- Press the front panel at the bottom until it clicks audibly into place (figure 5).
- Open the appliance door again slightly and remove the tea towel.
- Screw both screws back in on the left and right.
- Put the cover back in place and press on it until it clicks audibly into place (figure 6).

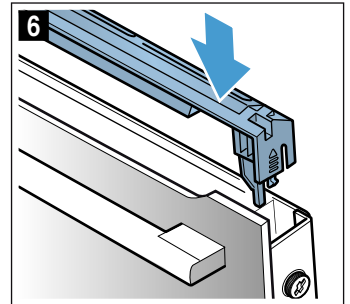
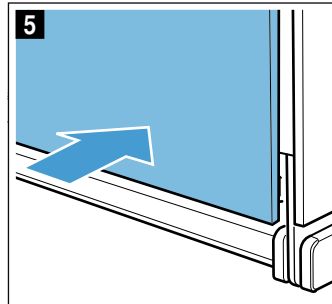

- Close the appliance door.

**Caution!**

Do not use the cooking compartment again until the panels have been correctly fitted.

## Trouble shooting

If a fault occurs, there is often a simple explanation. Before calling the after-sales service, please refer to the fault table and attempt to correct the fault yourself.

**Note:** If a dish does not turn out as well as you had hoped, refer to the table section at the end of the instruction manual, where you will find plenty of tips and information. → "Tested for you in our cooking studio" on page 30

### Fault table

If an error message beginning with 'E' is shown, e.g. E0111, switch the appliance off and then on again. If





#### **Warning – Risk of electric shock!**

Incorrect repairs are dangerous. Repairs may only be carried out and damaged power cables replaced by one of our trained after-sales technicians. If the appliance is defective, unplug the appliance from the mains or switch off the circuit breaker in the fuse box. Contact the after-sales service.

#### **Warning – Risk of injury!**

Incorrect repairs are dangerous. Do not attempt to repair the appliance yourself. Repairs must only be carried out by one of our trained after-sales engineers. If the appliance is defective, call the after-sales service.

this message appears again, contact the after-sales service.

| Fault  | Possible cause  | Information/remedial action   |
|--|---|---|
| The appliance does not work  | The fuse is faulty  | Check in the fuse box to make sure that the fuse for the appliance is in working order  |
|  | Power cut   | Check whether other kitchen appliances are working  |
| The appliance door will not open; the  symbol is shown in the display                             | The appliance door is locked until the cooking compartment has cooled down. | Wait until the  symbol goes out  |
| Although the appliance is switched on, it cannot be operated; the  symbol is shown in the display | The child lock is activated   | Press and hold the  button until the  symbol goes out |
| The cooking compartment does not heat and "Demo mode on" is shown in the display   | The appliance is in demo mode   | Switch off the fuse in the fuse box and switch it back on again after approx. 10 seconds. Switch on the appliance and select "Demo mode off" in the settings.   |
| The appliance will not start and "Cooking compartment too hot" appears on the display  | The cooking compartment is too hot for the selected dish or type of heating | Allow the cooking compartment to cool down and start again  |
| The interior lighting has failed   | The LED bulb is defective   | Call the after-sales service  |
| Home Connect does not work correctly.  |   | Go to <a href="http://www.home-connect.com">www.home-connect.com</a>  |

### Maximum operating time exceeded

Your appliance automatically ends the operation if no duration has been set and the setting has not been changed for a long time.

The point at which this occurs depends on the temperature or grill setting that has been set.

A message appears on the display on the appliance to say that the operation is being ended automatically. The operation is then cancelled.

To use the appliance again, first switch it off. To switch the appliance back on again set the required operation.

**Tip:** Set a cooking time so that the appliance does not switch off when you do not want it to, e.g. with an extremely long preparation time. The appliance heats up until the set cooking time has elapsed.

### Cooking compartment bulbs

To light the interior of your cooking compartment, your appliance has one or more long-life LED bulbs.

However, if ever an LED bulb or the bulb's glass cover is defective, call the after-sales service. The lamp cover must not be removed.

## Customer service

Our after-sales service is there for you if your appliance needs to be repaired. We will always find an appropriate solution, also in order to avoid after-sales personnel having to make unnecessary visits.

### E number and FD number

When calling us, please quote the full product number (E no.) and the production number (FD no.) so that we can provide you with the correct advice. The rating plate bearing these numbers can be found when you open the appliance door.

On some appliances with a steam-assisted cooking function, you will find the rating plate behind the control panel.

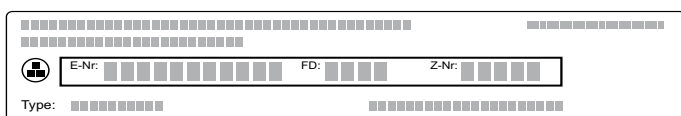

To save time, you can make a note of the numbers for your appliance and the telephone number of the after-sales service in the space below in case you need them.

| E no. | FD no. |
|-------|--------|
|-------|--------|

### After-sales service

Please note that a visit from an after-sales service engineer is not free of charge in the event that the appliance has been misused, even during the warranty period.

Please find the contact data of all countries in the enclosed customer service list.

#### To book an engineer visit and product advice

**GB** 0344 892 8999

Calls charged at local or mobile rate.

**IE** 01450 2655

0.03 € per minute at peak. Off peak 0.0088 € per minute.

Rely on the professionalism of the manufacturer. You can therefore be sure that the repair is carried out by trained service technicians who carry original spare parts for your appliances.

## Dishes

You can use the "Dishes" operating mode to prepare a wide variety of food. The appliance chooses the optimal setting for you.

To achieve good results, the cooking compartment must not be too hot for the type of food you have selected. If it is, a message will appear on the display. Allow the cooking compartment to cool down and start again.

### Information on the settings

- The cooking result depends on the quality of the food and the size and type of cookware. For an optimal cooking result, use food that is in good condition and chilled meat only. For frozen food, use food straight out of the freezer only.
- For some food, a temperature, heating mode and cooking time is suggested. The temperature and the cooking time can be changed according to your requirements.
- For other dishes, you will be asked to enter the weight. Always enter the total weight unless the appliance asks for something different. The appliance will then apply the time and temperature settings for you. It is not possible to set weights outside of the intended weight range.
- When roasting dishes for which the appliance will apply the temperature selection for you, temperatures of up to 300 °C can be saved. Therefore, make sure that you use cookware that is sufficiently heat resistant.
- Information is provided, e.g. on cookware, shelf position or the addition of liquid when cooking meat. Some food requires turning or stirring, etc., during cooking. This is shown in the display shortly after operation starts. An audible signal will remind you at the right time.
- Information on the right kind of cookware to use and tips and tricks for the preparation can be found at the end of the instruction manual. → "Tested for you in our cooking studio" on page 30

### Meat thermometer

For some food, you can also use the meat thermometer. Once you have inserted the meat thermometer into the appliance, the food that is suitable for it will be displayed. You can change the interior temperature of the cooking compartment and the core temperature. → "Meat thermometer" on page 17



## Selecting a dish

The dishes are arranged in a uniform structure:

- Category
- Food
- Dish

The following table lists the categories with the corresponding food. One or more dishes are listed beside each food.

| Categories          | Food                                      |
|---------------------|---|
| Cakes, bread, pizza | Cake                                      |
|                     | Small baked items                         |
|                     | Biscuits                                  |
|                     | Bread and rolls                           |
|                     | Savoury cakes, pizza, quiches             |
| Bakes, soufflés     | Bake, savoury, fresh, cooked ingredients  |
|                     | Lasagne, fresh                            |
|                     | Potato gratin, raw ingredients, 4 cm deep |
|                     | Bake, sweet, fresh                        |
|                     | Soufflé in individual moulds              |
| Frozen products     | Pizza                                     |
|                     | Bread rolls                               |
|                     | Bakes                                     |
|                     | Potato products                           |
|                     | Poultry, fish                             |
| Poultry             | Chicken                                   |
|                     | Duck, goose                               |
|                     | Turkey                                    |
| Meat                | Pork                                      |
|                     | Beef                                      |
|                     | Veal                                      |
|                     | Lamb                                      |
|                     | Game                                      |
|                     | Meat dishes                               |
| Fish                | Fish                                      |
| Vegetables          | Vegetable stew                            |
|                     | Vegetables au gratin                      |
|                     | Baked potatoes, halved                    |
|                     | Baked potatoes, whole                     |

## Baking sensor

Your appliance is equipped with a baking sensor. This sensor is automatically activated when you select a baked item from any of the following categories in the selection list. If the baking sensor has been activated, the  symbol appears on the display.

| Category                     | Food              | Dishes                |
|------------------------------|-------------------|-----------------------|
| Cake, bread, pizza           | Cake              | Cakes in tins         |
|                              |                   | Cakes on trays        |
|                              |                   | Pies/tarts            |
|                              | Small baked items | Puff pastry           |
|                              |                   | Muffins               |
|                              |                   | Leavened cake         |
|                              | Bread/bread rolls | Bread rolls           |
|                              |                   | Bread                 |
|                              |                   | Flatbread             |
|                              |                   | Savoury cakes, quiche |
| Savoury cakes, pizza, quiche | Pizza             |                       |
|                              | Tarte flambée     |                       |
| Frozen products              | Potato products   | Potato products       |

The appliance now takes over. The appliance then regulates the baking process completely automatically – you do not need to implement any further settings. Once the food is cooked, the appliance will switch itself off automatically. An audible signal will then sound. The cooking time is roughly the same as that listed in the recipe for your baked item and is not displayed. The oven sensor can only be started from the oven when it is cool.

No other baked goods categories are monitored by the baking sensor. In this case, you will be offered a tried and tested setting with customisation options.

Dark-coloured metal baking tins are suitable. Do not use any silicone bakeware or accessories that contain silicone. Otherwise, the baking sensor will be damaged.

The baking sensor is active while "Do not open door" is shown on the display. Do not open the appliance door; otherwise, the settings will be cancelled. The appliance will continue to heat and you can adjust the suggested time. You must monitor the process yourself.

## Applying settings for dishes

You will be guided through the entire setting process for your chosen food. Always touch the "Next" field.

1. Press the menu button.  
The operating modes menu will open.
2. Select "Dishes" mode.  
The first category will appear on the display.
3. Use the rotary selector to select the category you require.
4. Touch the "Next" field.
5. Use the rotary selector to select the food.
6. Touch the "Next" field.
7. Use the rotary selector to select the dish.
8. Touch the "Next" field.
9. Turn the rotary selector to set the weight.

**Note:** Touch the "Tip" field for information on the best shelf position, cookware, etc. to use.

10. Press the Start/Stop button to start.

### The setting has ended

A signal sounds. "Finished" appears in the status bar. The oven stops heating. You can cancel the audible signal early using the ⏸ button.

If you are not satisfied with the cooking result, you can increase the cooking time again. Touch the "Extend cooking time" field. A cooking time is suggested. However, you can change this if you want.

If you are satisfied with the cooking result, touch "Finish". "Enjoy your meal" appears in the display.

### Cancelling the setting

Press the On/Off button. All settings are deleted. You can implement new settings.

### Setting a later end time

For some dishes, it is possible to set a later end time. You can find out how to set a later end time by looking in the time-setting options. → *"Time-setting options" on page 14*

Once you have set an end time, the display shows the waiting time. The status bar shows the time at which operation is to end. None of the settings can be changed. Please remember that easily spoiled foods must not be allowed to remain in the cooking compartment for too long.

## Tested for you in our cooking studio

Here, you can find a selection of dishes and the ideal settings for them. We will show you which type of heating and temperature are best suited to your dish. You will get information on suitable cooking accessories and the height at which they should be placed in the oven. You will also get tips about cookware and preparation methods.

**Note:** A lot of steam can build up in the cooking compartment when cooking food. Your appliance is very energy-efficient and radiates very little heat to its surroundings during operation. Due to the high difference in temperature between the appliance interior and the external parts of the appliance, condensation may build up on the door, control panel or adjacent kitchen cabinet panels. This is a normal physical phenomenon. Condensation can be reduced by preheating the oven or opening the door carefully.

### Do not use silicone moulds

For best results, we recommend using dark-coloured metal bakeware.

#### Caution!

Do not use silicone moulds or reusable baking tray liners, covers or accessories that contain silicone. Otherwise, the baking sensor may be damaged. Even if the baking sensor is not being used, it may still be damaged.

Exceptions:

- Greaseproof paper with a silicone coating can be used.
- If the appliance comes with a meat probe, this can be used.

### Cakes and small baked items

Your appliance offers you a range of heating types for the preparation of cakes and small baked items. You can find the ideal settings for many dishes in the settings tables.

Also refer to the notes in the section on allowing dough to rise.

Only use original accessories supplied with your appliance. These have been tailored to the cooking compartment and the operating modes of your appliance.

### Shelf positions

Use the indicated shelf positions.

#### Baking on one level

When baking on one level, use the following shelf positions:

- Tall baked items: Level 2
- Flat baked items: Level 3

If you are using 4D Hot air as the type of heating, you can choose between levels 1, 2, 3 and 4.

### Baking on several levels

Use 4D hot air. Baked items that are placed into the oven on trays or in baking tins/dishes at the same time will not necessarily be ready at the same time.

Baking on two levels:

- Universal pan: Level 3  
Baking tray: Level 1
- Baking tins/dishes on the wire rack  
First wire rack: Level 3  
Second wire rack: Level 1

Baking on three levels:

- Baking tray: Level 5  
Universal pan: Level 3  
Baking tray: Level 1

Baking on four levels:

- 4 wire racks with greaseproof paper  
First wire rack: Level 5  
Second wire rack: Level 3  
Third wire rack: Level 2  
Fourth wire rack: Level 1

By preparing several dishes at the same time, you can make energy savings of up to 45 per cent. Position baking tins/dishes next to one another or offset and vertically stacked in the cooking compartment.

### Accessories

Ensure that you always use suitable accessories and that they are placed in the oven the right way around.

#### Wire rack

Insert the wire rack with the open side facing the appliance door and the curved lip pointing downwards. Always place ovenware, tins and dishes on the wire rack.

#### Universal pan or baking tray

Slide the universal pan or the baking tray in carefully as far as the limit stop with the bevelled edge facing the appliance door.

When baking moist cakes or pastries with many toppings, use the universal pan so that any excess liquid does not overflow and make the cooking compartment dirty.

#### Baking tins

Dark- coloured metal baking tins are most suitable.

Tinplate baking tins, ceramic dishes and glass dishes extend baking time and mean that the baked item will not brown evenly. If you wish to bake using these baking tins/dishes and using top/bottom heating, slide in the tin/dish at level 1.

#### Greaseproof paper

Only use greaseproof paper that is suitable for the selected temperature. Always cut greaseproof paper to size.

### Recommended setting values

The table lists the optimal heating type for various baked items. The temperature and baking time depend on the amount and consistency of the dough/mixture. For this reason, the table specifies setting ranges. Try using the lower values to start with. A lower temperature will result in more even browning. You can use a higher setting next time if necessary.

**Note:** Baking times cannot be reduced by using higher temperatures. Cakes or small baked items would only be cooked on the outside, and would not be fully baked in the middle.



The setting values apply to food that is placed into a cold cooking compartment; by doing this, you can make energy savings of up to 20 per cent. If you preheat the oven, you can reduce the indicated baking times by several minutes.





Preheating is necessary for selected food, and this is indicated in the table. Do not place your food or accessories into the cooking compartment until it has finished preheating.

If you wish to follow one of your own recipes when baking, you should use the setting values listed for similar baked items in the table as reference. Additional information can be found in the baking tips listed after the settings table.

Remove unused accessories from the cooking compartment. This will ensure that you achieve the best possible cooking results and energy savings of up to 20 per cent.

Types of heating used:

-  4D hot air
-  Top/bottom heating
-  Intensive heat

| Dish   | Accessories/cookware     | Shelf position | Heating function  | Temperature in °C | Cooking time in mins. |
|--|--------------------------|----------------|---|-------------------|-----------------------|
| <b>Cakes in tins</b>                                   |                          |                |   |                   |                       |
| Sponge cake, simple                                    | Ring tin/cake tin        | 2              |  | 150-170           | 50-70                 |
| Sponge cake, simple, 2 levels                          | Ring tin/cake tin        | 3+1            |  | 140-160           | 60-80                 |
| Sponge cake, delicate                                  | Ring tin/cake tin        | 2              |  | 150-170           | 60-80                 |
| Fruit flan made from sponge mixture, delicate          | Ring/springform cake tin | 2              |  | 160-180           | 40-60                 |
| Sponge flan base                                       | Flan base tin            | 3              |  | 160-180           | 20-30                 |
| * Preheat  |                          |                |   |                   |                       |
| ** Preheat for 5 mins., do not use quick heat function |                          |                |   |                   |                       |

| Dish   | Accessories/cookware         | Shelf position | Heating function | Temperature in °C | Cooking time in mins. |
|--|------------------------------|----------------|------------------|-------------------|-----------------------|
| Fruit tart or cheesecake with shortcrust pastry base   | Springform cake tin, Ø 26 cm | 2              |                  | 160-180           | 70-90                 |
| Swiss flan   | Pizza tray                   | 3              |                  | 190-210           | 50-60                 |
| Tart   | Flan-base cake tin, black    | 1              |                  | 220-240           | 25-35                 |
| Bundt yeast cake                                       | Ring cake tin                | 2              |                  | 150-170           | 50-70                 |
| Yeast cake   | Springform cake tin, Ø 28 cm | 2              |                  | 160-170           | 20-30                 |
| Sponge base, 2 eggs                                    | Flan base tin                | 3              |                  | 150-170*          | 20-30                 |
| Sponge flan, 3 eggs                                    | Springform cake tin, Ø 26 cm | 2              |                  | 160-170*          | 25-35                 |
| Sponge flan, 6 eggs                                    | Springform cake tin, Ø 28 cm | 2              |                  | 150-170*          | 30-50                 |
| <b>Cakes on baking trays</b>                           |                              |                |                  |                   |                       |
| Sponge cake with topping                               | Baking tray                  | 3              |                  | 160-180           | 20-40                 |
| Sponge cake, 2 levels                                  | Universal pan + baking tray  | 3+1            |                  | 140-160           | 30-50                 |
| Shortcrust tart with dry topping                       | Baking tray                  | 3              |                  | 180-200           | 25-30                 |
| Shortcrust tart with dry topping, 2 levels             | Universal pan + baking tray  | 3+1            |                  | 160-170           | 35-45                 |
| Shortcrust tart with moist topping                     | Universal pan                | 3              |                  | 160-180           | 55-65                 |
| Swiss flan   | Universal pan                | 3              |                  | 200-210           | 50-60                 |
| Yeast cake with dry topping                            | Universal pan                | 3              |                  | 160-180           | 15-20                 |
| Yeast cake with dry topping, 2 levels                  | Universal pan + baking tray  | 3+1            |                  | 150-170           | 20-30                 |
| Yeast cake with moist topping                          | Universal pan                | 3              |                  | 180-200           | 30-40                 |
| Yeast cake with moist topping, 2 levels                | Universal pan + baking tray  | 3+1            |                  | 150-170           | 45-60                 |
| Plaited loaf, savarin                                  | Baking tray                  | 2              |                  | 160-170           | 25-35                 |
| Swiss roll   | Baking tray                  | 3              |                  | 180-200*          | 8-15                  |
| Stollen with 500 g flour                               | Baking tray                  | 2              |                  | 150-170           | 45-60                 |
| Strudel, sweet   | Universal pan                | 2              |                  | 170-180           | 50-60                 |
| Strudel, frozen  | Universal pan                | 3              |                  | 200-220           | 35-45                 |
| <b>Small baked items</b>                               |                              |                |                  |                   |                       |
| Small cakes  | Baking tray                  | 3              |                  | 160**             | 20-30                 |
| Small cakes  | Baking tray                  | 3              |                  | 150**             | 25-35                 |
| Small cakes, 2 levels                                  | Universal pan + baking tray  | 3+1            |                  | 150**             | 25-35                 |
| Small cakes, 3 levels                                  | Baking trays + universal pan | 5+3+1          |                  | 140**             | 35-45                 |
| Muffins  | Muffin tray                  | 3              |                  | 170-190           | 15-20                 |
| Muffins, 2 levels                                      | Muffin trays                 | 3+1            |                  | 160-180*          | 15-30                 |
| Small yeast cakes                                      | Baking tray                  | 3              |                  | 160-180           | 25-35                 |
| Small yeast cakes, 2 levels                            | Universal pan + baking tray  | 3+1            |                  | 150-170           | 25-40                 |
| Puff pastry  | Baking tray                  | 3              |                  | 170-190*          | 20-35                 |
| Puff pastry, 2 levels                                  | Universal pan + baking tray  | 3+1            |                  | 170-190*          | 20-45                 |
| Puff pastry, 3 levels                                  | Baking trays + universal pan | 5+3+1          |                  | 170-190*          | 20-45                 |
| Puff pastry, flat, 4 levels                            | 4 wire racks                 | 5+3+2+1        |                  | 180-200*          | 20-35                 |
| Choux pastry   | Baking tray                  | 3              |                  | 200-220           | 30-40                 |
| Choux pastry, 2 levels                                 | Universal pan + baking tray  | 3+1            |                  | 190-210           | 35-45                 |
| Danish pastry  | Baking tray                  | 3              |                  | 160-180           | 20-30                 |
| * Preheat  |                              |                |                  |                   |                       |
| ** Preheat for 5 mins., do not use quick heat function |                              |                |                  |                   |                       |

| Dish                | Accessories/cookware         | Shelf position | Heating function  | Temperature in °C | Cooking time in mins. |
|---------------------|------------------------------|----------------|---|-------------------|-----------------------|
| <b>Biscuits</b>     |                              |                |   |                   |                       |
| Viennese whirls     | Baking tray                  | 3              |  | 140-150**         | 25-40                 |
| Viennese whirls     | Baking tray                  | 3              |  | 140-150**         | 25-40                 |
| Whirls, 2 levels    | Universal pan + baking tray  | 3+1            |  | 140-150**         | 30-40                 |
| Whirls, 3 levels    | Baking trays + universal pan | 5+3+1          |  | 130-140**         | 35-55                 |
| Biscuits            | Baking tray                  | 3              |  | 140-160           | 15-30                 |
| Biscuits, 2 levels  | Universal pan + baking tray  | 3+1            |  | 140-160           | 15-30                 |
| Biscuits, 3 levels  | Baking trays + universal pan | 5+3+1          |  | 140-160           | 15-30                 |
| Meringue            | Baking tray                  | 3              |  | 80-90*            | 120-150               |
| Meringue, 2 levels  | Universal pan + baking tray  | 3+1            |  | 80-90*            | 120-180               |
| Macaroons           | Baking tray                  | 3              |  | 90-110            | 20-40                 |
| Macaroons, 2 levels | Universal pan + baking tray  | 3+1            |  | 90-110            | 25-45                 |
| Macaroons, 3 levels | Baking trays + universal pan | 5+3+1          |  | 90-110            | 30-45                 |

\* Preheat

\*\* Preheat for 5 mins., do not use quick heat function

### Tips on baking

|   |   |
|---|---|
| You want to find out whether the cake is completely cooked in the middle.   | Push a cocktail stick into the highest point on the cake. If the cocktail stick comes out clean with no dough residue, the cake is ready.   |
| The cake collapses.   | Next time, use less liquid. Alternatively, set the temperature to be 10 °C lower and extend the baking time. Adhere to the specified ingredients and preparation instructions in the recipe.  |
| The cake has risen in the middle but is lower around the edge.  | Only grease the base of the springform cake tin. After baking, loosen the cake carefully with a knife.  |
| The fruit juice overflows.  | Next time, use the universal pan.   |
| Small baked items stick to one another during baking.   | There should be a gap of approx. 2 cm around each item. This gives enough space for the baked items to expand well and brown on all sides.  |
| The cake is too dry.  | Set the temperature 10 °C higher and shorten the baking time.   |
| The cake is generally too light in colour.  | If the shelf position and the cookware are correct, then you should increase the temperature if necessary or extend the baking time.  |
| The cake is too light on top, and too dark underneath.  | Bake the cake one level higher in the oven the next time.   |
| The cake is too dark on top, and too light underneath.  | Bake the cake one level lower in the oven the next time. Select a lower temperature and extend the baking time.   |
| Cakes baked in a tray or tin are too brown at the back.   | Place the baking tray in the middle of the accessories, not directly against the back wall.   |
| The whole cake is too dark.   | Select a lower temperature next time and extend the baking time if necessary.   |
| The cake is unevenly browned.   | Select a slightly lower temperature.<br>Protruding greaseproof paper can affect the air circulation. Always cut greaseproof paper to size.<br>Ensure that the baking tin does not stand directly in front of the openings in the cooking compartment back wall.<br>When baking small items, you should use similar sizes and thicknesses wherever possible. |
| You were baking on several levels. The items on the top baking tray are darker than those on the lower baking tray. | Always select 4D hot air when baking on several levels. Baked items that are placed into the oven on trays or in baking tins/dishes at the same time will not necessarily be ready at the same time.  |



|  |   |
|--|---|
| The cake looks good, but is not cooked properly in the middle.           | Use a lower temperature and bake slightly longer; if necessary, add slightly less liquid. For cakes with a moist topping, bake the base first. Sprinkle it with almonds or breadcrumbs and then place the topping on top.   |
| The cake cannot be turned out of the dish when it is turned upside down. | Allow the cake to cool down for 5 to 10 minutes after baking. If it still sticks, carefully loosen the cake around the edges again using a knife. Turn the cake tin upside down again and cover it several times with a cold, wet cloth. Next time, grease the baking tin/dish and sprinkle with breadcrumbs. |

## Bread and rolls

Your appliance offers you a range of heating types for baking bread and rolls. You can find the ideal settings for many dishes in the settings tables.

Also refer to the notes in the section on allowing dough to rise.

Only use original accessories supplied with your appliance. These have been tailored to the cooking compartment and the operating modes of your appliance.

### Shelf positions

Use the indicated shelf positions.

#### Baking on one level

When baking on one level, use the following shelf positions:

- Tall baked items: Level 2
- Flat baked items: Level 3

If you are using 4D Hot air as the type of heating, you can choose between levels 1, 2, 3 and 4.

#### Baking on two levels

Use 4D hot air. Baked items that are placed into the oven on trays or in baking tins/dishes at the same time will not necessarily be ready at the same time.

- Universal pan: Level 3  
Baking tray: Level 1
- Baking tins/dishes on the wire rack  
First wire rack: Level 3  
Second wire rack: Level 1

By preparing several dishes at the same time, you can make energy savings of up to 45 per cent. Position baking tins/dishes next to one another or offset and vertically stacked in the cooking compartment.

### Accessories

Ensure that you always use suitable accessories and that they are placed in the oven the right way around.

#### Wire rack

Insert the wire rack with the open side facing the appliance door and the curved lip pointing downwards. Always place ovenware, tins and dishes on the wire rack.

#### Universal pan or baking tray

Slide the universal pan or the baking tray in carefully as far as the limit stop with the bevelled edge facing the appliance door.

#### Baking tins

Dark- coloured metal baking tins are most suitable.

Tinplate baking tins, ceramic dishes and glass dishes extend baking time and mean that the baked item will not brown evenly. If you wish to bake using these baking tins/dishes and using top/bottom heating, slide in the tin/dish at level 1.

### Greaseproof paper

Only use greaseproof paper that is suitable for the selected temperature. Always cut greaseproof paper to size.

### Frozen products

Do not use frozen products that are heavily frosted. Remove any ice on the food.

Some frozen products may be unevenly pre-baked. Uneven browning may remain even after baking.

### Recommended setting values

The table lists the optimal heating type for various kinds of bread and bread roll. The temperature and baking time depend on the amount and consistency of the dough/mixture. For this reason, the table specifies setting ranges. Try using the lower values to start with. A lower temperature will result in more even browning. You can use a higher setting next time if necessary.

**Note:** Baking times cannot be reduced by using higher temperatures. The bread or bread rolls would only be cooked on the outside, but would not be fully baked in the middle.

The setting values apply to food that is placed into a cold cooking compartment; by doing this, you can make energy savings of up to 20 per cent. If you preheat the oven, you can reduce the indicated baking times by several minutes.

Preheating is necessary for selected food, and this is indicated in the table. Do not place your food or accessories into the cooking compartment until it has finished preheating. Some food turns out best if it is baked in several stages. These foods are indicated in the table.

The setting values for bread dough apply to both dough placed on a baking tray and dough placed in a loaf tin.



If you wish to follow one of your own recipes when baking, you should use the setting values listed for similar baked items in the table as reference.



Remove unused accessories from the cooking compartment. This will ensure that you achieve the best possible cooking results and energy savings of up to 20 per cent.















### Caution!

Never pour water into the hot cooking compartment or place cookware containing water onto the bottom of the cooking compartment. The change in temperature can cause damage to the enamel.

Types of heating used:

-  4D hot air
-  Top/bottom heating

-  Circulated air grilling
-  Grill, large area
-  coolStart function

| Dish  | Accessories                 | Shelf position | Type of heating   | Temperature in °C | Grill setting | Cooking time in mins. |
|---|-----------------------------|----------------|---|-------------------|---------------|-----------------------|
| <b>Bread</b>                                |                             |                |   |                   |               |                       |
| White bread, 750 g                          | Universal pan or cake tin   | 2              |    | 210-220*          | -             | 10-15                 |
|   |                             |                |   | 180-190           | -             | 25-35                 |
| Multigrain bread, 1.5 kg                    | Universal pan or cake tin   | 2              |    | 210-220*          | -             | 10-15                 |
|   |                             |                |   | 180-190           | -             | 40-50                 |
| Wholemeal bread, 1 kg                       | Universal pan               | 2              |    | 210-220*          | -             | 10-15                 |
|   |                             |                |   | 180-190           | -             | 40-50                 |
| Flatbread                                   | Universal pan               | 3              |    | 250-270           | -             | 20-25                 |
| <b>Bread rolls</b>                          |                             |                |   |                   |               |                       |
| Part-cooked rolls or baguette, pre-baked**  | Universal pan               | 3              |    | -                 | -             | -                     |
| Bread rolls, sweet, fresh                   | Baking tray                 | 3              |    | 170-190*          | -             | 15-20                 |
| Bread rolls, sweet, fresh, 2 levels         | Universal pan + baking tray | 3+1            |    | 150-170*          | -             | 20-30                 |
| Bread rolls, fresh                          | Baking tray                 | 3              |    | 180-200           | -             | 20-30                 |
| Baguette, pre-baked, chilled**              | Universal pan               | 3              |   | -                 | -             | -                     |
| <b>Bread rolls, frozen</b>                  |                             |                |   |                   |               |                       |
| Part-cooked rolls or baguette, pre-baked**  | Universal pan               | 3              |  | -                 | -             | -                     |
| Lye bread, pieces of dough**                | Universal pan               | 3              |  | -                 | -             | -                     |
| Croissant, pieces of dough                  | Universal pan               | 3              |  | 170-190           | -             | 30-35                 |
| <b>Toast</b>                                |                             |                |   |                   |               |                       |
| Toast with topping, 4 slices                | Wire rack                   | 3              |  | 190-210           | -             | 10-15                 |
| Toast with topping, 12 slices               | Wire rack                   | 3              |  | 230-250           | -             | 10-15                 |
| Toasting bread (do not preheat)             | Wire rack                   | 5              |  | -                 | 3             | 4-6                   |
| * Preheat                                   |                             |                |   |                   |               |                       |
| ** Observe the information on the packaging |                             |                |   |                   |               |                       |

## Pizza, quiche and savoury cakes

Your appliance offers you a range of heating types for preparing pizza, quiche and savoury cakes. You can find the ideal settings for many dishes in the settings tables.

Also refer to the notes in the section on allowing dough to rise.

Only use original accessories supplied with your appliance. These have been tailored to the cooking compartment and the operating modes of your appliance.

### Shelf positions

Use the indicated shelf positions.

### Baking on one level

When baking on one level, use the following shelf positions:

- Tall baked items: Level 2
- Flat baked items: Level 3

If you are using 4D Hot air as the type of heating, you can choose between levels 1, 2, 3 and 4.

### Baking on several levels

Use 4D hot air. Baked items that are placed into the oven on trays or in baking tins/dishes at the same time will not necessarily be ready at the same time.

Baking on two levels:

- Universal pan: Level 3  
Baking tray: Level 1
- Baking tins/dishes on the wire rack  
First wire rack: Level 3  
Second wire rack: Level 1

Baking on four levels:

- 4 wire racks with greaseproof paper
  - First wire rack: Level 5
  - Second wire rack: Level 3
  - Third wire rack: Level 2
  - Fourth wire rack: Level 1

By preparing several dishes at the same time, you can make energy savings of up to 45 per cent. Position baking tins/dishes next to one another or offset and vertically stacked in the cooking compartment.

### Accessories

Ensure that you always use suitable accessories and that they are placed in the oven the right way around.

#### Wire rack

Insert the wire rack with the open side facing the appliance door and the curved lip pointing downwards. Always place ovenware, tins and dishes on the wire rack.

#### Universal pan or baking tray

Slide the universal pan or the baking tray in carefully as far as the limit stop with the bevelled edge facing the appliance door.

Use the universal pan for pizzas with many toppings.

#### Baking tins

Dark- coloured metal baking tins are most suitable.

Tinplate baking tins, ceramic dishes and glass dishes extend baking time and mean that the baked item will not brown evenly. If you wish to bake using these baking tins/dishes and using top/bottom heating, slide in the tin/dish at level 1.

#### Greaseproof paper

Only use greaseproof paper that is suitable for the selected temperature. Always cut greaseproof paper to size.

### Frozen products

Do not use frozen products that are heavily frosted. Remove any ice on the food.

Some frozen products may be unevenly pre-baked. Uneven browning may remain even after baking.

### Recommended setting values

The table lists the optimal heating type for various types of food. The temperature and baking time depend on the amount and consistency of the dough/mixture. For this reason, the table specifies setting ranges. Try using the lower values to start with. A lower temperature will result in more even browning. You can use a higher setting next time if necessary.

**Note:** Baking times cannot be reduced by using higher temperatures. The food would only be cooked on the outside, but would not be fully baked in the middle.





The setting values apply to food that is placed into a cold cooking compartment; by doing this, you can make energy savings of up to 20 per cent. If you preheat the oven, you can reduce the indicated baking times by several minutes.









Preheating is necessary for selected food, and this is indicated in the table. Do not place your food or accessories into the cooking compartment until it has finished preheating.

If you wish to follow one of your own recipes when baking, you should use the setting values listed for similar baked items in the table as reference.

Remove unused accessories from the cooking compartment. This will ensure that you achieve the best possible cooking results and energy savings of up to 20 per cent.

Types of heating used:

-  4D hot air
-  Top/bottom heating
-  Pizza setting
-  Intensive heat
-  coolStart function

| Dish  | Accessories                 | Shelf position | Type of heating   | Temperature in °C | Cooking time in mins. |
|---|-----------------------------|----------------|---|-------------------|-----------------------|
| <b>Pizza</b>                                |                             |                |   |                   |                       |
| Pizza, fresh                                | Baking tray                 | 3              |  | 200-220           | 25-35                 |
| Pizza, fresh                                | Baking tray                 | 3              |  | 200-220           | 25-35                 |
| Pizza, fresh, 2 levels                      | Universal pan + baking tray | 3+1            |  | 180-200           | 35-45                 |
| Pizza, fresh, thin base                     | Pizza tray                  | 2              |  | 220-230           | 20-30                 |
| Pizza, chilled**                            | Wire rack                   | 3              |  | -                 | -                     |
| <b>Pizza, frozen</b>                        |                             |                |   |                   |                       |
| Pizza, thin base, x 1**                     | Wire rack                   | 3              |  | -                 | -                     |
| Pizza, thin base, x 2                       | Universal pan + wire rack   | 3+1            |  | 190-210           | 20-25                 |
| Pizza, deep-pan, x 1**                      | Wire rack                   | 3              |  | -                 | -                     |
| Pizza, deep-pan, x 2                        | Universal pan + wire rack   | 3+1            |  | 190-210           | 20-30                 |
| * Preheat                                   |                             |                |   |                   |                       |
| ** Observe the information on the packaging |                             |                |   |                   |                       |

| Dish  | Accessories                         | Shelf position | Type of heating | Temperature in °C | Cooking time in mins. |
|---|-------------------------------------|----------------|-----------------|-------------------|-----------------------|
| Pizza baguette**                            | Wire rack                           | 3              |                 | -                 | -                     |
| Mini pizzas**                               | Universal pan                       | 3              |                 | -                 | -                     |
| Mini pizzas, diameter 7 cm, 4 levels        | 4 wire racks                        | 5+3+2+1        |                 | 180-200*          | 20-30                 |
| <b>Savoury cakes and quiches</b>            |                                     |                |                 |                   |                       |
| Savoury cakes in a tin                      | Springform cake tin, diameter 28 cm | 2              |                 | 180-200           | 60-70                 |
| Quiche                                      | Flan-base cake tin, black           | 1              |                 | 190-210           | 40-50                 |
| Tarte flambée                               | Universal pan                       | 3              |                 | 280-300*          | 10-18                 |
| Pierogi                                     | Ovenproof dish                      | 2              |                 | 190-200           | 30-45                 |
| Empanada de atún                            | Universal pan                       | 3              |                 | 180-190           | 30-45                 |
| Börek                                       | Universal pan                       | 3              |                 | 200-210           | 30-40                 |
| * Preheat                                   |                                     |                |                 |                   |                       |
| ** Observe the information on the packaging |                                     |                |                 |                   |                       |

## Bakes and soufflés

Your appliance offers a range of heating types for preparing bakes and soufflés. You can find the ideal settings for many dishes in the settings tables.

Only use original accessories supplied with your appliance. These have been tailored to the cooking compartment and the operating modes of your appliance.

### Shelf positions

Always use the indicated shelf positions.

You can prepare dishes on one level using a baking tin/dish or the universal pan.

- Baking tins/dishes on the wire rack: Level 2
- Universal pan: Level 3

You can also prepare soufflés in a water bath in the universal pan. To do so, slide the universal pan in at level 2.

By preparing several dishes at the same time, you can make energy savings of up to 45 per cent. Position baking tins/dishes next to one another in the cooking compartment.

### Accessories

Ensure that you always use suitable accessories and that they are placed in the oven the right way around.

#### Wire rack

Insert the wire rack with the open side facing the appliance door and the curved lip pointing downwards. Always place ovenware, tins and dishes on the wire rack.

#### Universal pan

Slide in the universal pan carefully as far as the limit stop, with the bevelled edge facing the appliance door.

#### Cookware

Use wide, shallow cookware for bakes and gratins. In deep, narrow cookware, food requires more time to cook, and the top will be darker.

## Recommended setting values

In the table, you can find the ideal heating type for various bakes and soufflés. The temperature and cooking time are dependent on the quantity of food and the recipe. How well cooked a bake is will depend on the size of the cookware and the depth of the bake. Settings ranges are indicated for this reason. Try using the lower values at first. A lower temperature results in more even browning. You can increase the temperature next time if necessary.



**Note:** Cooking times cannot be reduced by using higher temperatures. Bakes or soufflés would only be cooked on the outside, but would be raw in the middle.



The setting values apply to dishes placed into a cold cooking compartment. By doing so, you can make energy savings of up to 20 per cent. If you preheat the oven, the indicated cooking times will be reduced by several minutes.









If you wish to follow one of your own recipes when cooking, you can use similar dishes in the table as a reference.

Remove unused accessories from the cooking compartment. This will achieve the best possible cooking results and energy savings of up to 20 per cent.

Types of heating used:

-  4D hot air
-  Top/bottom heating

-  Pizza setting
-  coolStart function

| Bakes & soufflés                                    | Accessories/cookware | Shelf position | Type of heating   | Temperature in °C | Cooking time in mins. |
|---|----------------------|----------------|---|-------------------|-----------------------|
| Bake, savoury, cooked ingredients                   | Ovenproof dish       | 2              |  | 200-220           | 30-50                 |
| Bake, sweet   | Ovenproof dish       | 2              |  | 170-190           | 40-60                 |
| Lasagne, fresh, 1 kg                                | Ovenproof dish       | 2              |  | 160-180           | 50-60                 |
| Lasagne, frozen, 400 g*                             | Wire rack            | 2              |  | -                 | -                     |
| Potato gratin, raw ingredients, 4 cm deep           | Ovenproof dish       | 2              |  | 160-190           | 50-70                 |
| Potato gratin, raw ingredients, 4 cm deep, 2 levels | Ovenproof dish       | 3+1            |  | 150-170           | 60-80                 |
| Soufflé   | Ovenproof dish       | 2              |  | 160-180*          | 35-45                 |
| Soufflé   | Individual moulds    | 2              |  | 170-190           | 65-75                 |

\* Observe information on the packaging

## Poultry

Your appliance offers you a range of heating types for preparing poultry. You can find the ideal settings for certain dishes in the settings tables.

### Roasting on the wire rack

Roasting on the wire rack is particularly well suited for larger poultry or for multiple pieces at the same time.

Slide the universal pan into the oven at the indicated shelf position with the wire rack attached. Ensure that the wire rack is correctly positioned on the universal pan. → "Accessories" on page 11

Depending on the size and type of the poultry, pour up to 1/2 litres of water into the universal pan. Any dripping fat will be caught. You can make a sauce from these juices. This will also result in less smoke and ensure that the cooking compartment stays cleaner.

### Roasting in cookware

Only use cookware which is suitable for use in an oven. Check whether the cookware fits in the cooking compartment.

Glass cookware is most suitable. Place hot glass cookware onto a dry mat after cooking. If the surface is damp or cold, the glass may crack.

Shiny roasting dishes made from stainless steel or aluminium reflect heat like a mirror and are therefore not particularly suitable. The poultry cooks slower and does not brown so well. Use a higher temperature and/or a longer cooking time.

Observe the manufacturer's instructions for your roasting cookware.

### Uncovered cookware

It is best to use a deep roasting tin/dish for roasting poultry. Place the tin/dish onto the wire rack. If you do not have any suitable cookware, use the universal pan.

### Covered cookware

When cooking with covered cookware, the cooking compartment remains considerably cleaner. Ensure that

the lid fits well and closes properly. Place the cookware onto the wire rack.

Very hot steam may escape when opening the lid after cooking. Lift the lid at the rear, so that the hot steam can escape away from you.

Poultry can also become crispy in a covered roasting dish. To do so, use a roasting dish with a glass lid and set a higher temperature.

### Grilling

Keep the appliance door closed when using the grill. Never grill with the appliance door open.

Place the food to be grilled on the wire rack. In addition, slide the universal pan in at least one shelf position lower, with the slanted edge facing the appliance door. Any dripping fat will be caught.

When grilling, try wherever possible to use pieces of food which are of a similar thickness and weight. This will allow them to brown evenly and remain succulent and juicy. Place the food to be grilled directly onto the wire rack.

Use tongs to turn the pieces of food you are grilling. If you pierce the meat with a fork, the juices will run out and it will become dry.

### Notes

- The grill element switches itself continuously on and off; this is normal. The grill setting determines how frequently this occurs.
- Smoke may be produced when grilling.

### Meat thermometer

You can cook accurately using a meat thermometer. Read important notes on using the meat thermometer in the corresponding chapter. There, you can find notes on inserting the meat thermometer, the possible heating types and additional information. → "Meat thermometer" on page 17



## Recommended setting values

In the table, you can find the ideal heating type for the kind of poultry you are cooking. The temperature and cooking time depend on the amount, composition and temperature of the food. Setting ranges are indicated for this reason. Try using the lower values at first. You can increase the temperature next time if necessary.

The setting values are based on the assumption that unstuffed, chilled, ready-to-roast poultry is placed into a cold cooking compartment. By doing so, you can make energy savings of up to 20 per cent. If you preheat the oven, the indicated cooking times will be reduced by several minutes.

In the table, you can find specifications for poultry with default values for the weight. If you wish to cook heavier poultry, use the lower temperature in every case. If cooking multiple pieces, use the weight of the heaviest piece as a reference for determining the cooking time. The individual pieces should be approximately equal in size.

A general rule: the larger the poultry is, the lower the cooking temperature and the longer the cooking time.

Turn the poultry after approx.  $\frac{1}{2}$  to  $\frac{2}{3}$  of the indicated time.





**Note:** Only use greaseproof paper that is suitable for the selected temperature. Always cut greaseproof paper to size.













## Tips

- For duck or goose, pierce the skin on the underside of the wings. This allows the fat to run out.
- If using duck breast, score the skin. Do not turn duck breasts.
- When you turn poultry, ensure that the breast side or the skin side is underneath at first.
- Poultry will turn out particularly crispy and brown if you baste it towards the end of the roasting time with butter, salted water or orange juice.

Remove unused accessories from the cooking compartment. This will achieve the best possible cooking results and energy savings of up to 20 per cent.

Types of heating used:

-  Top/bottom heating
-  Circulated air grilling
-  Grill, large area
-  coolStart function

| Dish   | Accessories/cookware | Shelf position | Type of heating   | Temperature in °C | Grill setting | Cooking time in mins. |
|--|----------------------|----------------|---|-------------------|---------------|-----------------------|
| <b>Chicken</b>                               |                      |                |   |                   |               |                       |
| Chicken, 1 kg                                | Wire rack            | 2              |  | 200-220           | -             | 60-70                 |
| Chicken breast fillet, 150 g each (grilling) | Wire rack            | 4              |  | -                 | 3*            | 15-20                 |
| Small chicken portions, 250 g each           | Wire rack            | 3              |  | 220-230           | -             | 30-35                 |
| Chicken goujons, nuggets, frozen             | Universal pan        | 3              |  | -                 | -             | -                     |
| Poulard, 1.5 kg                              | Wire rack            | 2              |  | 200-220           | -             | 70-90                 |
| <b>Duck and goose</b>                        |                      |                |   |                   |               |                       |
| Duck, 2 kg                                   | Wire rack            | 1              |  | 180-200           | -             | 90-110                |
| Duck breast, 300 g each                      | Wire rack            | 3              |  | 230-250           | -             | 25-30                 |
| Goose, 3 kg                                  | Wire rack            | 2              |  | 160-180           | -             | 120-150               |
| Goose legs, 350 g each                       | Wire rack            | 2              |  | 210-230           | -             | 40-50                 |
| <b>Turkey</b>                                |                      |                |   |                   |               |                       |
| Small turkey, 2.5 kg                         | Wire rack            | 2              |  | 180-200           | -             | 70-90                 |
| Turkey breast, boned, 1 kg                   | Cookware, covered    | 2              |  | 240-260           | -             | 80-100                |
| Turkey thigh, with bone, 1 kg                | Wire rack            | 2              |  | 180-200           | -             | 80-100                |

\* Preheat for 5 mins

## Meat

Your appliance offers you many heating types for preparing meat. You can find the ideal settings for many dishes in the settings tables.

### Roasting and braising

Baste lean meat with fat as required or cover it with strips of bacon.

Score the rind crosswise. If you turn the joint when cooking, ensure that the rind is underneath at first.

When the joint is ready, turn off the oven and allow it to rest for another 10 minutes in the cooking compartment. This allows the meat juices to be better distributed. Wrap the joint in aluminium foil if necessary. The recommended standing time is not included in the cooking time specified.

### Roasting on the wire rack

On the wire rack, meat will become very crispy on all sides.

Pour up to ½ litres of water into the universal pan, depending on the size and type of the meat. Dripping fat and meat juices will be caught. You can make a sauce using these juices. This will also result in less smoke and ensure that the cooking compartment stays cleaner.

Slide the universal pan into the oven at the indicated shelf position with the wire rack attached. Ensure that the wire rack is correctly positioned on the universal pan. → "Accessories" on page 11

### Roasting and braising in cookware

It is more convenient to roast and braise meat in cookware. You can take the joint out of the cooking compartment more easily in the cookware, and prepare the sauce in the cookware itself.

Only use cookware which is suitable for use in an oven. Check whether the cookware fits in the cooking compartment.

Glass cookware is most suitable. Place hot glass cookware onto a dry mat after cooking. If the surface is damp or cold, the glass may crack.

Add in a little liquid for roasting if the meat is lean. A covering of approx. ½ cm depth should be applied to the base of any glass cookware.

The amount of liquid is dependent on the type of meat, the cookware material and also on whether or not a lid is used. If preparing meat in an enamelled or dark metal roasting dish, it will need a little more liquid than if cooked in glass cookware.

The steam evaporates in the cookware when roasting. Carefully pour in more liquid if required.

Shiny roasting dishes made from stainless steel or aluminium reflect heat like a mirror and are therefore not particularly suitable. The meat cooks more slowly and will not brown so much. Use a higher temperature and/or a longer cooking time.

Observe the manufacturer's instructions for your roasting cookware.

### Uncovered cookware

Use a deep roasting tin/dish for roasting meat. Place the tin/dish onto the wire rack. If you do not have any suitable cookware, use the universal pan.

### Covered cookware

When cooking with covered cookware, the cooking compartment remains considerably cleaner. Ensure that the lid fits well and closes properly. Place the cookware onto the wire rack.

The distance between the meat and the lid must be at least 3 cm. The meat may rise.

Very hot steam may escape when opening the lid after cooking. Lift the lid at the rear, so that the hot steam can escape away from you.

If necessary, braise the meat first by searing it. Add water, wine, vinegar or a similar liquid to the braising liquid. A covering approx. 1-2 cm deep should be applied to the base of the cookware.

The steam evaporates in the cookware when roasting. Carefully pour in more liquid if required.

Meat can also become crispy in a covered roasting dish. To do so, use a roasting dish with a glass lid and set a higher temperature.

### Grilling

Keep the appliance door closed when using the grill. Never grill with the appliance door open.

Place the food to be grilled on the wire rack. In addition, slide the universal pan in at least one shelf position lower, with the slanted edge facing the appliance door. Any dripping fat will be caught.

When grilling, try wherever possible to use pieces of food which are of a similar thickness and weight. This will allow them to brown evenly and remain succulent and juicy. Place the food to be grilled directly onto the wire rack.

Use tongs to turn the pieces of food you are grilling. If you pierce the meat with a fork, the juices will run out and it will become dry.

Do not add salt until after the meat has been grilled. Salt draws water from the meat.

### Notes

- The grill element switches itself continuously on and off; this is normal. The grill setting determines how frequently this occurs.
- Smoke may be produced when grilling.

### Meat thermometer

You can cook accurately using a meat thermometer. Read important notes on using the meat thermometer in the corresponding chapter. There, you can find notes on inserting the meat thermometer, the possible heating types and additional information. → "Meat thermometer" on page 17

### Recommended setting values

You can find the ideal heating type for many meat dishes in the table. Temperature and cooking time depend on the amount, composition and temperature of the food. Settings ranges are indicated for this reason.

Try using the lower values at first. You can increase the temperature next time if necessary.

The setting values apply to chilled meat placed into the cold cooking compartment. By doing so, you can make energy savings of up to 20 per cent. If you preheat the oven, you can reduce the indicated cooking times by several minutes.

You can find information on roasts and default values for weights in the table. If you wish to roast a heavy joint of meat, you should definitely use a lower temperature. If roasting several joints, use the weight of the heaviest piece as a basis for determining the cooking time. The individual pieces should be approximately equal in size.



As a general rule: the larger a roasting joint is, the lower the cooking temperature and the longer the cooking time.



















Turn roasting joints and grilled items after approx.  $\frac{1}{2}$  to  $\frac{2}{3}$  of the indicated time.

If you wish to follow one of your own recipes, you should use similar dishes as a reference. You can find additional information in the tips on roasting, braising and grilling attached to the settings table.

Remove unused accessories from the cooking compartment. This will achieve the best possible cooking results and energy savings of up to 20 per cent.

Types of heating used:

-  Top/bottom heating
-  Circulated air grilling
-  Grill, large area

| Dish  | Accessories/cookware | Shelf position | Type of heating   | Temperature in °C | Grill setting | Cooking time in mins. |
|---|----------------------|----------------|---|-------------------|---------------|-----------------------|
| <b>Pork</b>   |                      |                |   |                   |               |                       |
| Joint of pork without rind, e.g. neck, 1.5 kg             | Cookware, uncovered  | 2              |    | 180-190           | -             | 110-130               |
| Joint of pork with rind, e.g. shoulder, 2 kg              | Wire rack            | 2              |    | 190-200           | -             | 130-140               |
| Pork tenderloin steak, 1.5 kg                             | Cookware, uncovered  | 2              |    | 220-230           | -             | 70-80                 |
| Fillet of pork, 400 g                                     | Wire rack            | 3              |   | 220-230           | -             | 20-25                 |
| Smoked pork on the bone, 1 kg (with a little added water) | Cookware, covered    | 2              |  | 210-230           | -             | 70-90                 |
| Pork steaks, 2 cm thick                                   | Wire rack            | 5              |  | -                 | 2             | 16-20                 |
| Pork medallions, 3 cm thick (preheat oven for 5 mins.)    | Wire rack            | 5              |  | -                 | 3*            | 8-12                  |
| <b>Beef</b>   |                      |                |   |                   |               |                       |
| Fillet of beef, medium, 1 kg                              | Wire rack            | 2              |  | 210-220           | -             | 40-50                 |
| Pot-roasted beef, 1.5 kg                                  | Cookware, covered    | 2              |  | 200-220           | -             | 130-160               |
| Sirloin, medium, 1.5 kg                                   | Wire rack            | 2              |  | 220-230           | -             | 60-70                 |
| Steak, 3 cm thick, medium (do not pre-heat)               | Wire rack            | 3              |  | -                 | 3             | 15-20                 |
| Burger, 3-4 cm thick                                      | Wire rack            | 4              |  | -                 | 3             | 25-30                 |
| <b>Veal</b>   |                      |                |   |                   |               |                       |
| Joint of veal, 1.5 kg                                     | Cookware, uncovered  | 2              |  | 160-170           | -             | 100-120               |
| Knuckle of veal, 1.5 kg                                   | Cookware, uncovered  | 2              |  | 200-210           | -             | 100-120               |
| <b>Lamb</b>   |                      |                |   |                   |               |                       |
| Leg of lamb, boned, medium, 1.5 kg                        | Cookware, uncovered  | 2              |  | 170-190           | -             | 50-80                 |
| Saddle of lamb on the bone**                              | Wire rack            | 2              |  | 180-190           | -             | 40-50                 |
| Lamb chop   | Wire rack            | 3              |  | -                 | 3             | 12-16                 |
| <b>Sausages</b>   |                      |                |   |                   |               |                       |
| Grilled sausages  | Wire rack            | 4              |  | -                 | 3             | 10-15                 |
| <b>Meat dishes</b>  |                      |                |   |                   |               |                       |
| Meat loaf, 1 kg   | Cookware, uncovered  | 2              |  | 170-180           | -             | 60-70                 |
| * Preheat   |                      |                |   |                   |               |                       |
| ** Do not turn  |                      |                |   |                   |               |                       |

## Tips on roasting and braising

|   |  |
|---|--|
| The cooking compartment becomes very dirty.   | Prepare your food in an enclosed roasting dish with higher temperature or use the grill tray. You will achieve the best roasting results if you use the grill tray. The grill tray can be bought later as a special accessory. |
| The roast is too dark and the crackling is burned in places, and/or the roast is too dry. | Check the shelf position and temperature. Select a lower temperature the next time and reduce the roasting time if necessary.  |
| The crackling is too thin.  | Increase the temperature or switch on the grill briefly at the end of the roasting time.   |
| The roast looks good but the juices are burnt.  | Next time, use a smaller roasting dish and add more liquid if necessary.   |
| The roast looks good but the juices are too clear and watery.                             | Next time, use a larger roasting dish and add less liquid if necessary.  |
| The meat gets burned during braising.   | The roasting dish and lid must fit together well and close properly.<br>Reduce the temperature and add more liquid when braising if necessary.   |

## Fish

Your appliance offers you a range of heating types for preparing fish. You can find the ideal settings for many dishes in the settings tables.

The whole fish does not have to be turned. Place the whole fish into the cooking compartment in swimming position with the dorsal fin facing upwards. Placing half a potato or a small oven-proof container in the stomach cavity of the fish will provide stability.

You can tell when the fish is cooked because the dorsal fin can be removed easily.

### Roasting and grilling on the wire rack

Place the food to be grilled on the wire rack. In addition, slide the universal pan in at least one shelf position lower, with the slanted edge facing the appliance door.

Pour up to ½ litres of water into the universal pan, depending on the size and type of the fish. Any dripping liquid will be caught. Less smoke is generated and the cooking compartment stays cleaner.

Keep the appliance door closed when using the grill. Never grill with the appliance door open.

When grilling, try wherever possible to use pieces of food which are of a similar thickness and weight. This will allow them to brown evenly and remain succulent and juicy. Place the food to be grilled directly onto the wire rack.

Use tongs to turn the pieces of food you are grilling. If you pierce the fish with a fork, the juices will run out and it will become dry.

### Notes

- The grill element switches itself continuously on and off; this is normal. The grill setting determines how frequently this occurs.
- Smoke may be produced when grilling.

### Roasting and stewing in cookware

Only use cookware which is suitable for use in an oven. Check whether the cookware fits in the cooking compartment.

Glass cookware is most suitable. Place hot glass cookware onto a dry mat after cooking. If the surface is damp or cold, the glass may crack.

Shiny roasting dishes made from stainless steel or aluminium reflect heat like a mirror and are therefore not particularly suitable. The fish cooks more slowly and browns less. Use a higher temperature and/or a longer cooking time.

Observe the manufacturer's instructions for your roasting cookware.

### Uncovered cookware

To cook a whole fish, it is best to use a deep roasting tin/dish. Place the tin/dish onto the wire rack. If you do not have any suitable cookware, use the universal pan.

### Covered cookware

When cooking with covered cookware, the cooking compartment remains considerably cleaner. Ensure that the lid fits well and closes properly. Place the cookware onto the wire rack.

When stewing, add two to three tablespoons of liquid and a little lemon juice or vinegar into the cookware.

Very hot steam may escape when opening the lid after cooking. Lift the lid at the rear, so that the hot steam can escape away from you.

Fish can also become crispy in a covered roasting dish. Here, use a roasting dish with a glass lid and set a higher temperature.

### Meat thermometer

You can cook accurately using a meat thermometer. Read important notes on using the meat thermometer in the corresponding chapter. There, you can find notes on inserting the meat thermometer, the possible heating types and additional information. → "Meat thermometer" on page 17

### Recommended setting values

You can find the ideal heating type for your fish dishes in the table. The temperature and cooking time depend on the amount, composition and temperature of the food. Settings ranges are indicated for this reason. Try using lower setting values first. You can use a higher setting next time if necessary.

The setting values are based on the assumption that chilled fish is placed into a cold cooking compartment. By doing so, you can make energy savings of up to 20 per cent. If you preheat the oven, you can reduce the indicated cooking times by several minutes.

In the table, you can find information for fish with default values for the weight. If you want to cook a heavier fish, you should definitely use the lower temperature. If cooking several fish, you should use the weight of the heaviest fish as a reference for determining the cooking time. The individual fish should be approximately the same size.



As a general rule: the larger a fish, the lower the cooking temperature and the longer the cooking time.







Turn any fish which is not in swimming position after approx.  $\frac{1}{2}$  to  $\frac{2}{3}$  of the indicated time.

**Note:** Only use greaseproof paper that is suitable for the selected temperature. Always cut greaseproof paper to size.

Remove unused accessories from the cooking compartment. This will achieve the best possible cooking results and energy savings of up to 20 per cent.

Types of heating used:

-  Top/bottom heating
-  Circulated air grilling
-  Grill, large area

| Dish   | Accessories/cookware | Shelf position | Type of heating   | Temperature in °C | Grill setting | Cooking time in mins. |
|--|----------------------|----------------|---|-------------------|---------------|-----------------------|
| <b>Fish</b>  |                      |                |   |                   |               |                       |
| Fish, grilled, whole 300 g, e.g. trout                       | Wire rack            | 2              |    | 170-190           | -             | 20-30                 |
| Fish, grilled, whole 1.5 kg, e.g. salmon                     | Wire rack            | 2              |    | 170-190           | -             | 30-40                 |
| <b>Fish fillets</b>  |                      |                |   |                   |               |                       |
| Fish fillet, plain, grilled                                  | Wire rack            | 4              |    | -                 | 1*            | 15-25                 |
| <b>Fish steaks</b>   |                      |                |   |                   |               |                       |
| Fish steak, 3 cm thick**                                     | Wire rack            | 4              |    | -                 | 3             | 10-20                 |
| <b>Fish, frozen</b>  |                      |                |   |                   |               |                       |
| Fish fillet, plain   | Cookware, covered    | 2              |  | 210-230           | -             | 20-30                 |
| Fish fillet, au gratin                                       | Wire rack            | 2              |  | 200-220           | -             | 45-60                 |
| Fish fingers (turn during cooking)                           | Universal pan        | 3              |  | 200-220           | -             | 20-30                 |
| * Preheat  |                      |                |   |                   |               |                       |
| ** Slide the universal pan in underneath at shelf position 2 |                      |                |   |                   |               |                       |

## Vegetables and side dishes

Here, you can find information for preparing grilled vegetables, potatoes and frozen potato products.

Remove unused accessories from the cooking compartment. This will allow you to achieve ideal cooking results and save energy.

### Shelf positions

Use the indicated shelf positions.

### Cooking on one level

Adhere to the specifications in the table.

### Cooking on two levels

Use 4D hot air. Food on different baking trays placed in the oven at the same time will not necessarily be ready at the same time.

- Universal pan: Level 3
- Baking tray: Level 1

### Accessories

Ensure that you always use suitable accessories and that they are placed in the oven the right way around.

### Wire rack

Insert the wire rack with the open side facing the appliance door and the curved lip pointing downwards.

Always place ovenware, tins and dishes on the wire rack.

### Universal pan or baking tray

Slide the universal pan or the baking tray in carefully as far as the limit stop with the bevelled edge facing the appliance door.

### Greaseproof paper

Only use greaseproof paper that is suitable for the selected temperature. Always cut greaseproof paper to size.

### Recommended setting values



In the table, you can find the ideal heating types for various dishes. The temperature and cooking time depend on the amount and composition of the food. Setting ranges are indicated for this reason. Try using the lower values at first. A lower temperature results in more even browning. You can use a higher setting next time if necessary.







The setting values apply to dishes placed into a cold cooking compartment. If you preheat the oven, the indicated cooking times will be reduced by several minutes.



If you wish to follow one of your own recipes when cooking, you can use similar dishes in the table as a reference.

Types of heating used:

-  4D hot air
-  Grill, large area
-  coolStart function

| Dish                                   | Accessories                 | Shelf position | Type of heating   | Temperature in °C | Grill setting | Cooking time in mins. |
|--|-----------------------------|----------------|---|-------------------|---------------|-----------------------|
| <b>Vegetable dishes</b>                |                             |                |   |                   |               |                       |
| Grilled vegetables                     | Universal pan               | 5              |  | -                 | 3             | 10-15                 |
| <b>Potatoes</b>                        |                             |                |   |                   |               |                       |
| Baked potatoes, halved                 | Universal pan               | 3              |  | 160-180           | -             | 45-60                 |
| <b>Potato products, frozen</b>         |                             |                |   |                   |               |                       |
| Potato rösti*                          | Universal pan               | 3              |  | -                 | -             | -                     |
| Potato pockets, filled*                | Universal pan               | 3              |  | -                 | -             | -                     |
| Croquettes*                            | Universal pan               | 3              |  | -                 | -             | -                     |
| Chips*                                 | Universal pan               | 3              |  | -                 | -             | -                     |
| Chips, 2 levels                        | Universal pan + baking tray | 3+1            |  | 190-210           | -             | 30-40                 |
| * Observe information on the packaging |                             |                |   |                   |               |                       |

## Yogurt

You can make your own yogurt using your appliance.

### Making yoghurt

Remove accessories and shelf supports from the cooking compartment. The cooking compartment must be empty. Do not open the appliance door while the appliance is in operation.

1. Heat 1 litre of milk (3.5% fat) to 90 °C on the hob and then leave it to cool down to 40 °C.

It is sufficient to heat UHT milk to 40 °C.

2. Stir in 150 g (chilled) yoghurt.
3. Pour into cups or small jars and cover with cling film.
4. Place the cups or jars onto the cooking compartment floor and use the settings indicated in the table.
5. After making the yoghurt, leave it to cool in the refrigerator.

Type of heating used:

-  4D hot air

| Dish   | Accessories       | Shelf position            | Type of heating   | Temperature in °C | Cooking time in hours |
|--------|-------------------|---------------------------|---|-------------------|-----------------------|
| Yogurt | Individual moulds | Cooking compartment floor |  | 40-45             | 8-9                   |

## Eco heating functions

Hot air eco and Top/bottom heating eco are intelligent heating functions that allow you to gently cook meat, fish and baked items. The appliance optimally controls the supply of energy to the cooking compartment. The food is cooked in phases using residual heat. This means that it remains more succulent and browns less. Depending on the method of preparation and the type of food, it is possible to save energy. If you open the appliance door before the food has finished cooking or if you preheat the appliance, you may not be able to achieve this result.

Only use genuine accessories for your appliance. These have been tailored to the cooking compartment and the operating modes of your appliance. Remove any accessories that are not being used from the cooking compartment.

Place the food into the empty cooking compartment before the oven is heated up. For Hot air eco, select a temperature of between 125 and 275 °C, and for Top/bottom heating eco, select a temperature of between 150 and 250 °C. Always keep the appliance door closed when cooking. Only cook on one level when using this function.

The Hot air eco heating function is used to measure both the energy consumption in air recirculation mode and the energy efficiency class. The Top/bottom heating eco heating function is used to measure the energy consumption in the conventional mode.

The Hot air eco heating type is used to determine the energy efficiency class.

### Accessories

Ensure that you always use suitable accessories and that they are placed in the oven the right way around.

**Wire rack**

Insert the wire rack with the open side facing the appliance door and the curved lip pointing downwards. Always place ovenware, tins and dishes on the wire rack.

**Universal pan or baking tray**

Slide the universal pan or the baking tray in carefully as far as the limit stop with the bevelled edge facing the appliance door.

**Baking tins and cookware**

Dark- coloured metal baking tins are most suitable. These allow you to make energy savings of up to 35 per cent.

Cookware made from stainless steel or aluminium reflects heat like a mirror. Non-reflective cookware made from enamel, heat-resistant glass or coated, die-cast aluminium is more suitable.

Tinplate baking tins, ceramic dishes or glass dishes prolong baking time, and the cake will not brown so evenly.

**Greaseproof paper**



Only use greaseproof paper that is suitable for the selected temperature. Always cut greaseproof paper to size.























**Recommended setting values**

Here, you can find specifications for various dishes. The temperature and baking time are dependent on the quantity and composition of the dough. Different settings ranges are indicated for this reason. Try using the lower values at first. A lower temperature results in more even browning. If necessary, use a higher setting the next time.

**Note:** Baking times can not be reduced by using higher temperatures. Cakes or baked items would only be cooked on the outside, but would not be cooked completely in the middle.

Types of heating used:

-  Hotair Eco
-  Top/bottom heating Eco

| Dish                             | Accessories/cookware                | Shelf position | Type of heating   | Temperature in °C | Cooking time in mins. |
|----------------------------------|-------------------------------------|----------------|---|-------------------|-----------------------|
| <b>Cakes in tins</b>             |                                     |                |   |                   |                       |
| Sponge cake in a tin             | Ring tin/cake tin                   | 2              |   | 140-160           | 60-80                 |
| Sponge flan base                 | Flan base tin                       | 2              |  | 150-170           | 20-30                 |
| Sponge base, 2 eggs              | Flan base tin                       | 2              |  | 150-170           | 20-30                 |
| Sponge flan, 3 eggs              | Springform cake tin, diameter 26 cm | 2              |  | 160-170           | 30-45                 |
| Sponge flan, 6 eggs              | Springform cake tin, diameter 28 cm | 2              |  | 150-160           | 50-60                 |
| Bundt yeast cake                 | Ring cake tin                       | 2              |  | 150-170           | 50-70                 |
| <b>Cakes on baking trays</b>     |                                     |                |   |                   |                       |
| Sponge cake with dry topping     | Baking tray                         | 3              |  | 150-170           | 25-40                 |
| Shortcrust tart with dry topping | Baking tray                         | 3              |  | 170-180           | 25-35                 |
| Swiss roll                       | Baking tray                         | 3              |  | 180-190           | 15-20                 |
| Plaited loaf, savarin            | Baking tray                         | 3              |  | 160-170           | 25-35                 |
| Yeast cake with dry topping      | Baking tray                         | 3              |  | 160-180           | 15-20                 |
| <b>Small baked items</b>         |                                     |                |   |                   |                       |
| Muffins                          | Muffin tray                         | 2              |  | 160-180           | 15-25                 |
| Small cakes                      | Baking tray                         | 3              |  | 150-160           | 25-35                 |
| Puff pastry                      | Baking tray                         | 3              |  | 170-190           | 20-35                 |
| Choux pastry                     | Baking tray                         | 3              |  | 200-220           | 35-45                 |
| Biscuits                         | Baking tray                         | 3              |  | 140-160           | 15-30                 |
| Whirls                           | Baking tray                         | 3              |  | 140-150           | 25-35                 |
| Small yeast cakes                | Baking tray                         | 3              |  | 160-180           | 25-35                 |
| <b>Bread and bread rolls</b>     |                                     |                |   |                   |                       |
| Multigrain bread, 1.5 kg         | Cake tin                            | 2              |  | 200-210           | 35-45                 |
| Flatbread                        | Universal pan                       | 3              |  | 250-275           | 15-20                 |
| Bread rolls, sweet, fresh        | Baking tray                         | 3              |  | 170-190           | 15-20                 |
| Bread rolls, fresh               | Baking tray                         | 3              |  | 180-200           | 20-30                 |

| Dish  | Accessories/cookware | Shelf position | Type of heating   | Temperature in °C | Cooking time in mins. |
|---|----------------------|----------------|---|-------------------|-----------------------|
| <b>Meat</b>                                   |                      |                |   |                   |                       |
| Joint of pork without rind, e.g. neck, 1.5 kg | Cookware, uncovered  | 2              |  | 180-190           | 120-140               |
| Pot-roasted beef, 1.5 kg                      | Cookware, covered    | 2              |  | 200-220           | 140-160               |
| Joint of veal, 1.5 kg                         | Cookware, uncovered  | 2              |  | 170-180           | 110-130               |
| <b>Fish</b>                                   |                      |                |   |                   |                       |
| Fish, braised, whole 300 g, e.g. trout        | Cookware, covered    | 2              |  | 190-210           | 25-35                 |
| Fish, braised, whole 1.5 kg, e.g. salmon      | Cookware, covered    | 2              |  | 190-210           | 45-55                 |
| Fish fillet, plain, braised                   | Cookware, covered    | 2              |  | 190-210           | 15-25                 |

## Acrylamide in foodstuffs

Acrylamide is mainly produced in grain and potato products prepared at high temperatures, such as potato

crisps, chips, sliced bread, bread rolls, bread or fine baked goods (biscuits, gingerbread, spiced biscuit).

| Tips for keeping acrylamide to a minimum |   |
|--|---|
| General                                  | <ul style="list-style-type: none"> <li>■ Keep cooking times as short as possible.</li> <li>■ Cook food until it is golden brown, but not too dark.</li> <li>■ Large, thick pieces of food contain less acrylamide.</li> </ul> |
| Baking                                   | With top/bottom heating at max. 200 °C.<br>With hot air at max. 180 °C.   |
| Biscuits                                 | With top/bottom heating at max. 190 °C.<br>With hot air at max. 170 °C.<br>Egg or egg yolk reduces the production of acrylamide.  |
| Oven chips                               | Spread out a single layer evenly on the baking tray. Cook at least 400 g at once on a baking tray so that the chips do not dry out.   |

## Slow cook

Slow cooking is a technique for cooking food over a long period at low temperatures. For this reason, it is also called "low-temperature cooking".

Slow cooking is ideal for all prime cuts (e.g. tender portions of beef, veal, pork, lamb or poultry) which are to be cooked "à point". The meat will remain succulent and tender.

The benefit of this cooking method is that it allows lots of scope for menu planning because slow-cooked meat is easy to keep warm. You do not have to turn the meat when cooking. Keep the appliance door closed in order to maintain an even cooking climate.

Only use fresh, clean and hygienic meat without bones. Carefully remove sinews and fat from around the edge. Fat develops a strong, distinct flavour during slow cooking. You can also use seasoned or marinated meat. Do not use defrosted meat.

Meat can be carved immediately following slow cooking. No standing time is required. Due to the special cooking method, the meat looks pink, but is not raw or undercooked.

**Note:** Delayed-start operation with an end time is not possible for the slow cooking heating type.

## Cookware

Use shallow cookware, e.g. a glass/porcelain serving dish. Place the cookware into the cooking compartment to preheat it.

Always place the uncovered cookware onto the wire rack at level 2.

You can find additional information in the tips on slow cooking attached to the settings table.

Your appliance features the heating type "Slow cook". Only start operation when the cooking compartment has fully cooled down. Allow the cooking compartment to warm up for approx. 15 minutes with the cookware inside.















Sear the meat on the hotplate at a very high heat and for a sufficiently long time on all sides, even on the ends. Place into the preheated cookware right away. Place the cookware containing the meat into the cooking compartment once again and cook slowly.

## Recommended setting values

The slow cooking temperature and cooking time are dependent on the size, thickness and quality of the meat. Different settings ranges are indicated for this reason.

Type of heating used:

-  Slow cooking

| Dish   | Cookware            | Shelf position | Heating function   | Searing time in mins | Temperature in °C | Cooking time in mins |
|--|---------------------|----------------|--|----------------------|-------------------|----------------------|
| <b>Poultry</b>                               |                     |                |  |                      |                   |                      |
| Duck breast, medium rare, 300 g each         | Cookware, uncovered | 2              |    | 6-8                  | 90*               | 45-60                |
| Chicken breast fillet, 200 g each, well done | Cookware, uncovered | 2              |    | 4                    | 120*              | 45-60                |
| Turkey breast, boned, 1 kg, well done        | Cookware, uncovered | 2              |    | 6-8                  | 120*              | 110-130              |
| <b>Pork</b>                                  |                     |                |  |                      |                   |                      |
| Pork tenderloin steak, 5-6 cm thick, 1.5 kg  | Cookware, uncovered | 2              |    | 6-8                  | 80*               | 130-180              |
| Fillet of pork, whole                        | Cookware, uncovered | 2              |    | 4-6                  | 80*               | 45-70                |
| <b>Beef</b>                                  |                     |                |  |                      |                   |                      |
| Joint of beef (rump), 6-7 cm thick, 1.5 kg   | Cookware, uncovered | 2              |    | 6-8                  | 100*              | 150-180              |
| Fillet of beef, 1 kg                         | Cookware, uncovered | 2              |    | 4-6                  | 80*               | 90-120               |
| Sirloin, 5-6 cm thick                        | Cookware, uncovered | 2              |    | 6-8                  | 80*               | 120-180              |
| Beef medallions/rump steak, 4 cm thick       | Cookware, uncovered | 2              |    | 4                    | 80*               | 30-60                |
| <b>Veal</b>                                  |                     |                |  |                      |                   |                      |
| Joint of veal, 4-5 cm thick, 1.5 kg          | Cookware, uncovered | 2              |  | 6-8                  | 80*               | 80-140               |
| Joint of veal, 7-10 cm thick, 1.5 kg         | Cookware, uncovered | 2              |  | 6-8                  | 80*               | 140-200              |
| Fillet of veal, whole, 800 g                 | Cookware, uncovered | 2              |  | 4-6                  | 80*               | 70-120               |
| Veal medallions, 4 cm thick                  | Cookware, uncovered | 2              |  | 4                    | 80*               | 30-50                |
| <b>Lamb</b>                                  |                     |                |  |                      |                   |                      |
| Saddle of lamb, boneless, 200 g each         | Cookware, uncovered | 2              |  | 4                    | 80*               | 30-45                |
| Leg of lamb, boned, medium, 1 kg, tied       | Cookware, uncovered | 2              |  | 6-8                  | 95*               | 120-180              |
| * Preheat                                    |                     |                |  |                      |                   |                      |

### Tips for slow cooking

|  |   |
|--|---|
| Slow-cooking duck breast.  | Place the cold duck breast into a pan and fry the skin side first. After slow cooking, grill for 3 to 5 minutes until crispy. |
| The slow-cooked meat is not as hot as conventionally roasted meat. | So that the roasted meat does not cool so quickly, warm the plates and serve the sauces very hot.                             |

### Drying

Your appliance features the heating type "Drying", using which you can dry fruit, vegetables and herbs with outstanding results. With this type of preserving, flavourings are concentrated by the dehydration.

Only use unblemished fruit, vegetables and herbs and wash them thoroughly. Line the wire rack with greaseproof paper or parchment paper. Drain the excess water from the fruit and dry it.

If necessary, cut it into equal chunks or thin slices. Place unpeeled fruit onto the dish with the sliced surfaces facing upwards. Ensure that neither fruit nor mushrooms overlap on the wire rack.

Grate vegetables and then blanch them. Allow the blanched vegetables to drain off and distribute them evenly on the wire rack.

Dry herbs on the stem. Position the herbs evenly and slightly heaped on the wire rack.

Use the following shelf positions for drying:

- 1 wire rack: Level 3
- 2 wire racks: Level 3+1
- 3 wire racks: Level 5+3+1
- 4 wire racks: Level 5+3+2+1

Turn very juicy fruit and vegetables several times. After drying, remove the dried products from the paper immediately.

## Recommended setting values











In the table, you can find settings for drying various foodstuffs. The temperature and cooking time are dependent on the type, moisture, ripeness and thickness of the food to be dried. The longer you leave the food to be dried, the better it will be preserved. The thinner the slices are, the quicker the drying process

will be and the more aromatic the dried food will remain. Setting ranges are indicated for this reason.

If you wish to dry additional foodstuffs, you should use similar foodstuffs in the table as a reference.

Type of heating used:

-  Drying

| Fruit, vegetables and herbs                          | Accessories    | Type of heating   | Temperature in °C | Cooking time in hours |
|--|----------------|---|-------------------|-----------------------|
| Pomes (apple rings, 3 mm thick, 200 g per wire rack) | 1-2 wire racks |  | 80                | 3-6                   |
| Pomes (apple rings, 3 mm thick, 200 g per wire rack) | 3-4 wire racks |  | 80                | 6-8                   |
| Stone fruit (plums)                                  | 1-2 wire racks |  | 80                | 4-8                   |
| Stone fruit (plums)                                  | 3-4 wire racks |  | 80                | 8-10                  |
| Root vegetables (carrots), grated, blanched          | 1-2 wire racks |  | 80                | 6-8                   |
| Root vegetables (carrots), grated, blanched          | 3-4 wire racks |  | 80                | 6-8                   |
| Sliced mushrooms                                     | 1-2 wire racks |  | 60                | 4-7                   |
| Sliced mushrooms                                     | 3-4 wire racks |  | 60                | 7-9                   |
| Herbs, washed  | 1-2 wire racks |  | 60                | 1-3                   |
| Herbs, washed  | 3-4 wire racks |  | 60                | 3-6                   |

## Preserving

You can preserve fruit and vegetables using your appliance.

### Warning – Risk of injury!

If the food is preserved incorrectly, the preserving jars may burst. Follow the instructions for preserving.

### Jars

Use only clean and undamaged preserving jars. Only use heat-resistant, clean and undamaged rubber rings. Check clips and clamps in advance.

For each preserving process, only use preserving jars that are the same size and contain the same food. In the cooking compartment, you can preserve the contents of a maximum of six ½, 1 or 1½-litre preserving jars at the same time. Do not use jars that are larger or taller than this. The lids could rupture.

Preserving jars must not touch one another in the cooking compartment during the preserving process.

### Preparing fruit and vegetables

Only use fruit and vegetables that are in good condition. Wash them thoroughly.

Peel, core and chop fruit and vegetables appropriate to their type and fill the preserving jars with them up to approx. 2 cm below the rim.

### Fruit

Fill the preserving jars with the fruit along with a hot, skimmed sugar solution (approx. 400 ml for a 1-litre jar). For one litre of water:

- Approx. 250 g sugar for sweet fruit
- Approx. 500 g sugar for sour fruit

### Vegetables

Fill the jars with the vegetables along with hot, boiled water.

Wipe the rims of the jars, as they must be clean. Place a damp rubber ring and a lid on each jar. Seal the jars with clamps. Place the jars into the universal pan so that they do not touch each other. Pour 500 ml hot water (approx. 80 °C) into the universal pan. Use the settings indicated in the table.

### Ending the preserving process

#### Fruit

After a short while, small bubbles will form at short intervals. Switch off the appliance once all preserving jars are bubbling. Remove the jars from the cooking compartment after the indicated cooling time.

#### Vegetables

After a short while, small bubbles will form at short intervals. As soon as all preserving jars are bubbling, reduce the temperature to 120 °C and allow the jars to continue to bubble in the closed cooking compartment as indicated in the table. After this time has elapsed, switch off the appliance and make use of the residual heat for several minutes as indicated in the table.

After preserving, remove the jars from the cooking compartment and place them onto a clean cloth. Do not place these hot jars onto a cold or damp surface, as they may crack. Cover the preserving jars to protect them from draughts. Only remove the clamps once the jars are cold.

### Recommended setting values





The indicated times in the settings table are average values for preserving fruit and vegetables. They may be influenced by room temperature, the number of jars, quantity, heat and quality of the jar contents. The specifications are based on 1-litre round jars. Before



you switch off the appliance or change the cooking mode, check whether the contents of the jars are bubbling as they should. The bubbling process starts after approx. 30-60 minutes.

Type of heating used:

-  4D hot air

| Preserving                          | Cookware                | Shelf position | Type of heating   | Temperature in °C | Cooking time in mins.            |
|-------------------------------------|-------------------------|----------------|---|-------------------|----------------------------------|
| Vegetables, e.g. carrots            | 1-litre preserving jars | 1              |  | 160-170           | Before it starts bubbling:30-40  |
|                                     |                         |                |   | 120               | When it starts to bubble: 30-40  |
|                                     |                         |                |   | -                 | Residual heat: 30                |
| Vegetables, e.g. cucumbers          | 1-litre preserving jars | 1              |  | 160-170           | Before it starts bubbling: 30-40 |
|                                     |                         |                |   | -                 | Residual heat: 30                |
| Stone fruit, e.g. cherries, damsons | 1-litre preserving jars | 1              |  | 160-170           | Before it starts bubbling:30-40  |
|                                     |                         |                |   | -                 | Residual heat:35                 |
| Pomes, e.g. apples, strawberries    | 1-litre preserving jars | 1              |  | 160-170           | Before it starts bubbling:30-40  |
|                                     |                         |                |   | -                 | Residual heat: 25                |

### Prove dough

You can prove yeast dough in your appliance more quickly than at room temperature. Use the top/bottom heating type. Only start operation when the cooking compartment has fully cooled down.

Always allow yeast dough to prove twice. Observe the specifications in the settings tables for the 1st and 2nd proving processes (dough fermentation and final fermentation).

#### Dough fermentation

Use the settings indicated in the table and heat up the appliance. Position the dough bowl on the wire rack.

Do not open the appliance door during the proving process, as moisture will escape. Cover the dough with a damp cloth.

#### Final fermentation

Place your baked item into the oven at the shelf position indicated in the table.





If you want to preheat the oven, the final fermentation takes place outside the appliance in a warm place.

#### Recommended setting values

The temperature and proving time are dependent on the type and quantity of the ingredients. The values in the table are therefore only meant to be average values.

Type of heating used:

-  Top/bottom heating

| Dish                        | Accessories/cookware | Shelf position | Type of heating  | Step               | Temperature in °C | Cooking time in mins. |
|-----------------------------|----------------------|----------------|--|--------------------|-------------------|-----------------------|
| Yeast dough, light          | Bowl                 | 2              |  | Dough fermentation | 35-40             | 25-30                 |
|                             | Baking tray          | 2              |  | Final fermentation | 35-40             | 10-20                 |
| Yeast dough, heavy and rich | Bowl                 | 2              |  | Dough fermentation | 35-40             | 20-40                 |
|                             | Baking tray          | 2              |  | Final fermentation | 35-40             | 15-25                 |

### Defrosting

Use heating type 4D hot air to defrost fruit, vegetables and baked items. Poultry, meat and fish should ideally be defrosted in the refrigerator.

Use the following shelf positions when defrosting:

- 1 wire rack: Level 2
- 2 wire racks: Level 3+1

#### Recommended setting values

The times in the table are average values. They are dependent on the quality, freezing temperature (-18 °C)

and composition of the food. Time ranges are indicated. Set the shortest time first and then extend the time if necessary.

**Tip:** Items which were frozen flat or portioned defrost faster than those frozen in a block.

Remove frozen food from the packaging and place it in suitable cookware onto the wire rack.



Stir the food or turn it once or twice in between. Large pieces of food should be turned several times. Occasionally split the food or remove items which have already defrosted from the cooking compartment.

en Tested for you in our cooking studio

Leave the defrosted food to rest for another 10 to 30 minutes in the appliance whilst it is switched off, so that the temperature balances out.

Type of heating used:

-  4D hot air

| Dish                        | Accessories | Shelf position | Type of heating   | Temperature in °C | Cooking time in mins. |
|-----------------------------|-------------|----------------|---|-------------------|-----------------------|
| <b>Bread, bread rolls</b>   |             |                |   |                   |                       |
| Bread & bread rolls general | Baking tray | 2              |  | 50                | 40-70                 |
| <b>Cake</b>                 |             |                |   |                   |                       |
| Cake, moist                 | Baking tray | 2              |  | 50                | 70-90                 |
| Cake, dry                   | Baking tray | 2              |  | 60                | 60-75                 |

## Keeping warm

You can keep cooked dishes warm using the "Keeping warm" heating type. This will avoid condensation developing, and means you will not have to wipe out the cooking compartment.

Do not keep cooked dishes warm for longer than two hours. Be aware that some dishes may continue cooking whilst being kept warm. Cover the dishes if necessary.

## Test dishes

These tables have been produced for test institutes to facilitate appliance testing.

As per EN 60350-1.

## Baking

Baked items that are placed into the oven on trays or in baking tins/dishes at the same time will not necessarily be ready at the same time.

Shelf positions for baking on two levels:

- Universal pan: Level 3  
Baking tray: Level 1
- Baking tins/dishes on the wire rack  
First wire rack: Level 3  
Second wire rack: Level 1

Shelf positions for baking on three levels:

- Baking tray: Level 5
- Universal pan: Level 3

- Baking tray: Level 1

## Apple pie

Apple pie on one level: place dark-coloured springform cake tins diagonally next to each other.

Apple pie on two levels: position dark-coloured springform cake tins above each other so that they are offset.

Cakes in tinplate springform cake tins: bake on one level with top/bottom heating. Place the springform cake tin onto the universal pan instead of onto the wire rack.





## Fatless sponge cake





Fatless sponge cake on two levels: vertically stack springform cake tins in an offset manner on the wire racks.

## Notes

- The setting values apply to dishes placed into a cold cooking compartment.
- Please note the information in the tables about preheating. The setting values are valid without rapid heating-up.
- For baking, use the lower of the indicated temperatures first.

Types of heating used:

-  4D hot air
-  Top/bottom heating
-  Pizza setting
-  Intensive heat

| Dish                 | Accessory                    | Shelf position | Type of heating   | Temperature in °C | Cooking time in mins. |
|----------------------|------------------------------|----------------|---|-------------------|-----------------------|
| <b>Baking</b>        |                              |                |   |                   |                       |
| Shortbread           | Baking tray                  | 3              |  | 140-150*          | 25-40                 |
| Shortbread           | Baking tray                  | 3              |  | 140-150*          | 25-40                 |
| Shortbread, 2 levels | Universal pan + baking tray  | 3+1            |  | 140-150*          | 30-40                 |
| Shortbread, 3 levels | Baking trays + universal pan | 5+3+1          |  | 130-140*          | 35-55                 |
| Small cakes          | Baking tray                  | 3              |  | 160*              | 20-30                 |

\* Preheat for 5 mins, do not use quick heat function

\*\* Preheat, do not use quick heat function

| Dish                          | Accessory                            | Shelf position | Type of heating | Temperature in °C | Cooking time in mins. |
|-------------------------------|--------------------------------------|----------------|-----------------|-------------------|-----------------------|
| Small cakes                   | Baking tray                          | 3              |                 | 150*              | 25-35                 |
| Small cakes, 2 levels         | Universal pan + baking tray          | 3+1            |                 | 150*              | 25-35                 |
| Small cakes, 3 levels         | Baking trays + universal pan         | 5+3+1          |                 | 140*              | 35-45                 |
| Fatless sponge cake           | Springform cake tin, diameter 26 cm  | 2              |                 | 160-170**         | 25-35                 |
| Fatless sponge cake           | Springform cake tin, diameter 26 cm  | 2              |                 | 160-170**         | 30-40                 |
| Fatless sponge cake, 2 levels | Springform cake tin, diameter 26 cm  | 3+1            |                 | 150-170**         | 30-50                 |
| Apple pie                     | 2 x black plate tins, diameter 20 cm | 2              |                 | 170-180           | 60-80                 |
| Apple pie                     | 2 x black plate tins, diameter 20 cm | 2              |                 | 170-180           | 75-95                 |
| Apple pie, 2 levels           | 2 x black plate tins, diameter 20 cm | 3+1            |                 | 170-190           | 70-90                 |

\* Preheat for 5 mins, do not use quick heat function  
 \*\* Preheat, do not use quick heat function

**Grilling**

Also slide in the universal pan. The liquid will be caught and the cooking compartment stays cleaner.

Type of heating used:

- Grill, large area

| Dish                    | Accessories | Shelf position | Type of heating | Grill setting | Cooking time in mins. |
|-------------------------|-------------|----------------|-----------------|---------------|-----------------------|
| <b>Grilling</b>         |             |                |                 |               |                       |
| Toasting bread*         | Wire rack   | 5              |                 | 3             | 4-6                   |
| Beefburger, 12 pieces** | Wire rack   | 4              |                 | 3             | 25-30                 |

\* Do not preheat  
 \*\* Turn after 2/3 of the total time

**BSH Hausgeräte GmbH**

Carl-Wery-Str. 34  
81739 München

GERMANY

Manufactured by BSH Hausgeräte GmbH under Trademark License of Siemens AG

[siemens-home.bsh-group.com](http://siemens-home.bsh-group.com)



9001377462 (990731)