



9001 358 805 (9803)

GV 640 Unterbau Vario-Tür 81,5 cm - k-SW

de Montageanleitung
*) über Kundendienst erhältlich

en Installation instructions
*) Available from customer service

fr Notice de montage
*) Disponible par le biais du service après-vente

nl Montagevoorschrift
*) Tegen meerprijs bij de Servicedienst verkrijgbaar

it Istruzioni per il montaggio
*) Disponibili presso il servizio assistenza clienti

es Instrucciones de montaje *) Se puede adquirir a través del Servicio de Asistencia Técnica Oficial de la marca

pt Instruções de montagem
*) Pode ser adquirido nos nossos Serviços Técnicos

el Οδηγίες τοποθέτησης
*) Διατίθενται από την υπηρεσία τεχνικής εξυπηρέτησης πελατών

tr Montaj kılavuzu
*) Yetkili servis üzerinden alınabilir

sv Monteringsanvisning
*) kan fås via Service

no Monteringsanvisning
*) fåes hos kundeservice

da Monteringsvejledning
*) Kan købes hos serviceafdelingen

fi Asennusohje
*) Saatavissa huoltopalvelusta

cs Montážní návod
*) K dispozici přes servisní službu

sk Návod na montáž
*) Dostanete v službe zákazníkom

pl Instrukcja montażu
*) Do uzyskania w punkcie serwisowym

hu Szerelési utasítás
*) A vevőszolgálaton keresztül kapható:

ro Instrucțiune de montaj
*) obținabilă la serviciul pentru clienți

hr Uputa za montažu
*) može dobiti kod službe održavanja

sr Uputstvo za montažu
*) Može se nabaviti preko servisne službe

sl Navodilo za montažo
*) Lahko nabavite v servisni službi

mk Упатство за монтажа
*) се добива преку службата за купувачи

sq Udhëzues për montim
*) Sigurohet nëpërmjet servisit

et Monteerimisjuhend
*) küsige klienditeeninduselt

lt Montavimo instrukcija
*) Ja galima gauti klientų aptarnavimo servise

lv Montāžas pamācība
*) Var saņemt servisa dienestā

ru Инструкция по монтажу
*) Можно получить в сервисном центре

uk Інструкція з монтажу
*) Можна отримати через сервісну службу

kk Іске қосу туралы нұсқаулар!
*) Сервис қызмет көрсету орталығында алуына жатады

az Quraşdırma təlimatları
*) Müşəri xidmətlərindən əldə oluna bilər

uz O'rnatish yo'riqnomasi
*) mijozlarga xizmat ko'rsatish markazida mavjud

ka მონტაჟის ინსტრუქცია
*) ხელმისაწვდომი კლიენტთა სამსახურში

bg Ръководство за монтаж
*) предоставя се от службата за обслужване на клиенти

fa راهنمایی مونتاژ
*) از مرکز خدمات پس از فروش تهیه فرمائید

ar تعليمات التركيب
*) يمكن طلبها من مراكز خدمة العملاء

id Intruksi Pemasangan
*) bisa didapatkan melalui Customer Service

th สามารถสั่งซื้อคู่มือการติดตั้ง
*) ผ่านฝ่ายบริการลูกค้า

ko 설치 설명서
*) 고객센터 센터에서 구입 가능

zh 安装说明书
*) 可向售后服务站索取。

zh-tw 安裝說明書
*) 可向售後服務站索取

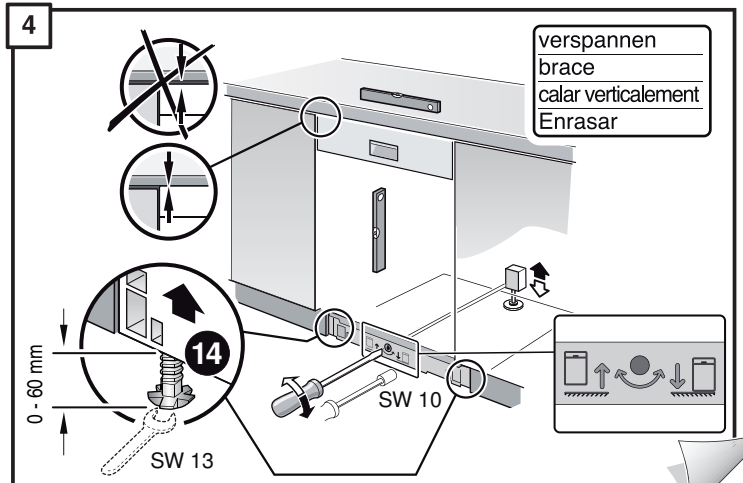
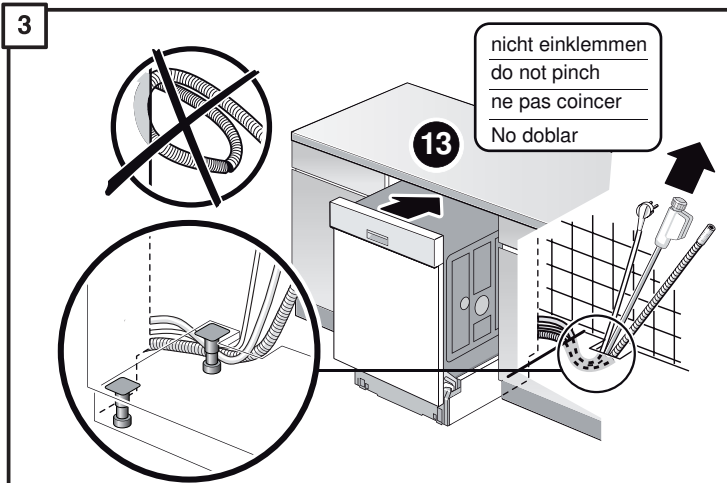
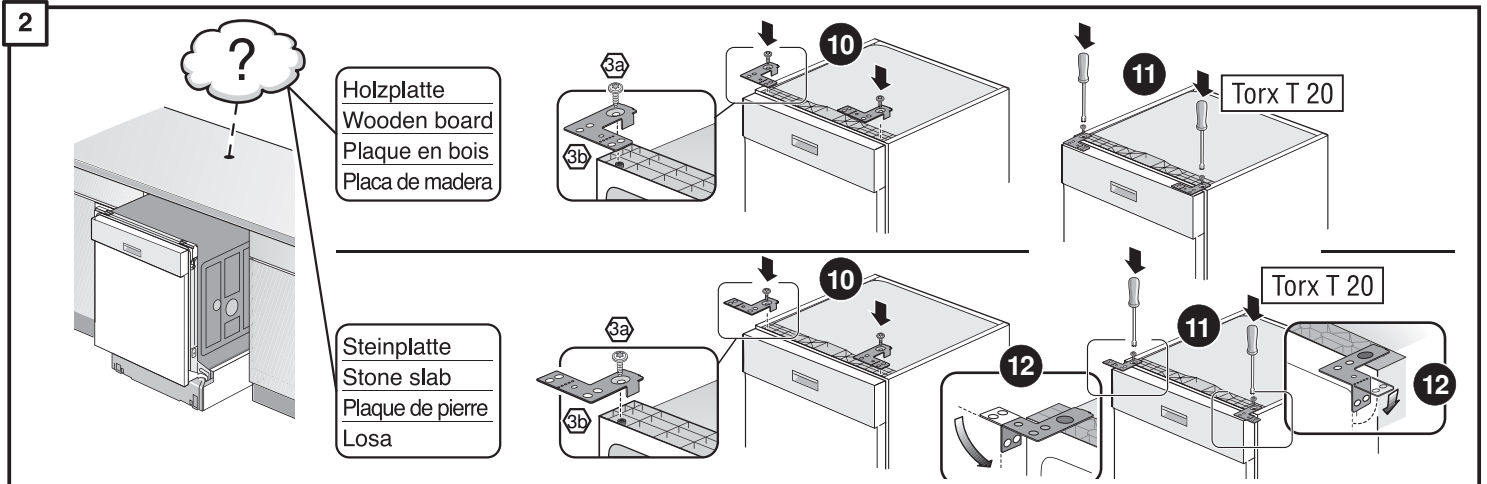
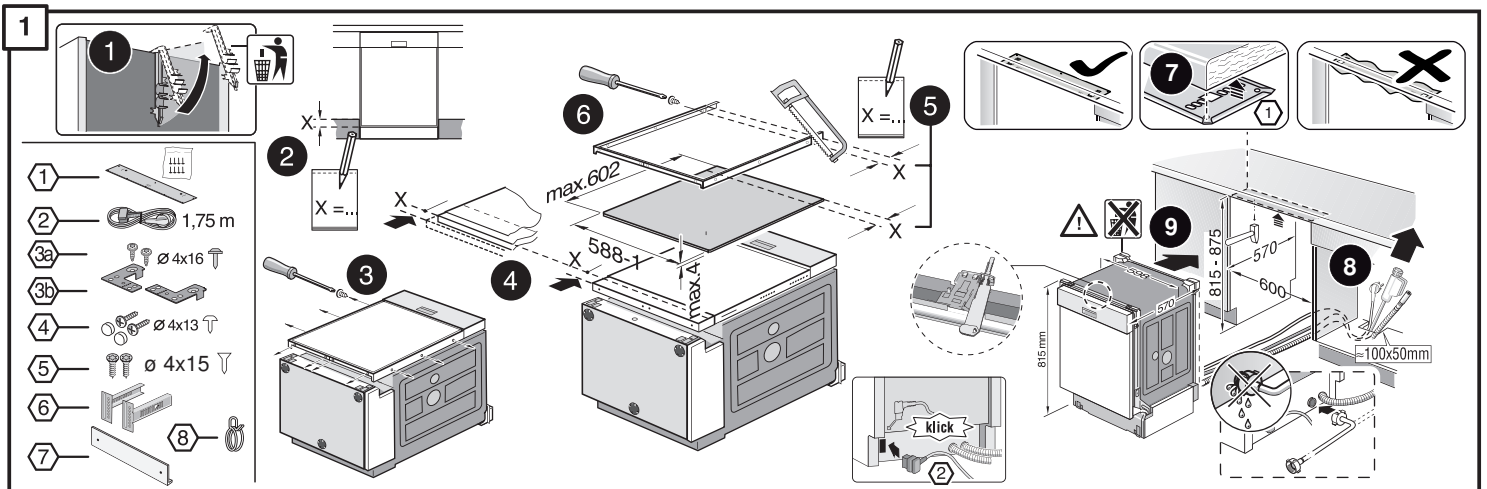

5

Holzplatte
Wooden board
Plaque en bois
Placa de madera



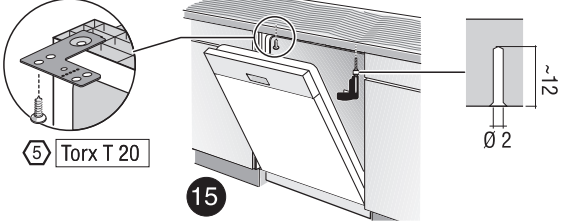

5 Torx T 20

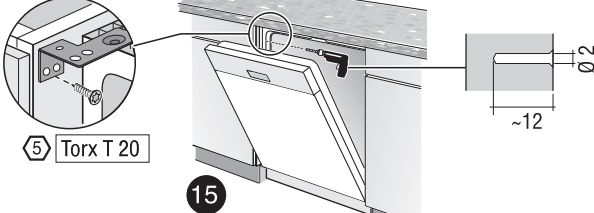

5 Torx T 20

6

Diagram showing the installation of the base plate (7) under the cabinet. A question mark icon is present.

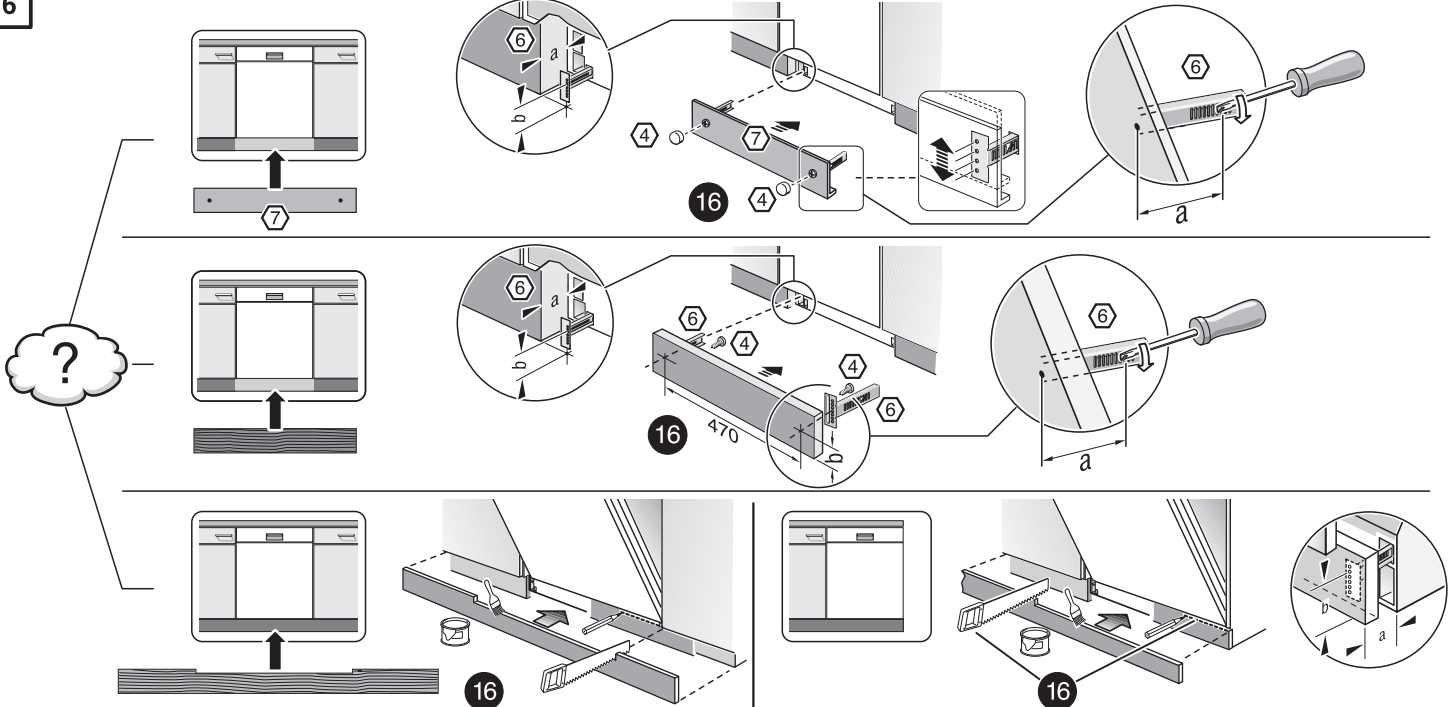

6

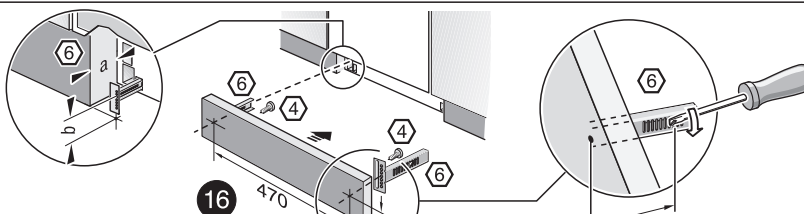

6

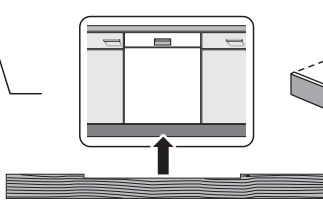

6

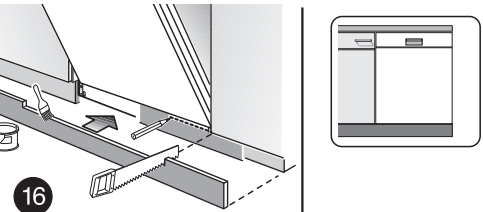

6

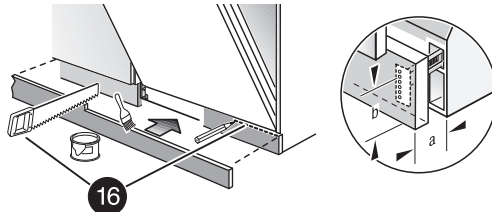

6

7

Scheibe entfernen
remove disc
enlever le disque
Eliminar disco

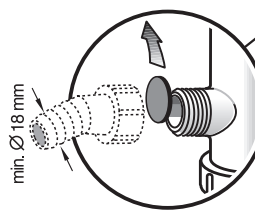

min. Ø 18 mm

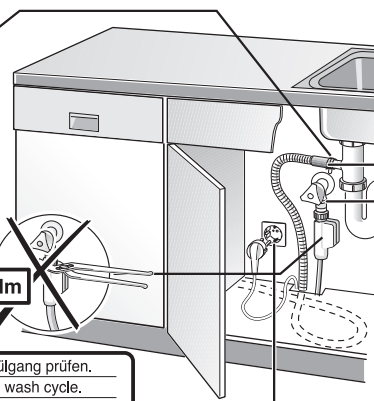

max. 10 Nm

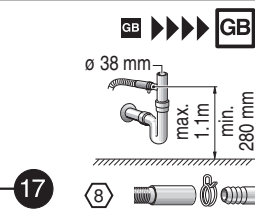

Ø 38 mm
max. 1.1 m
min. 280 mm

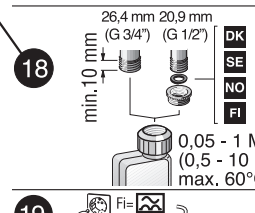

26,4 mm 20,9 mm
(G 3/4") (G 1/2")
min. 10 mm

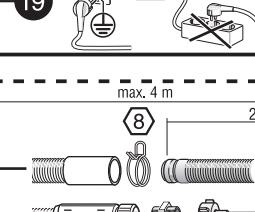

0,05 - 1 MPa
(0,5 - 10 bar)
max. 60°C

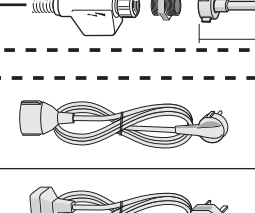

3 m EU
3 m GB

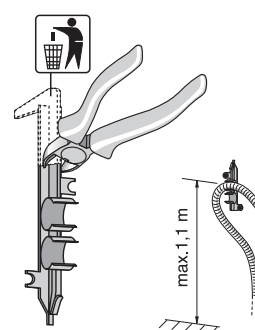

max. 1,1 m

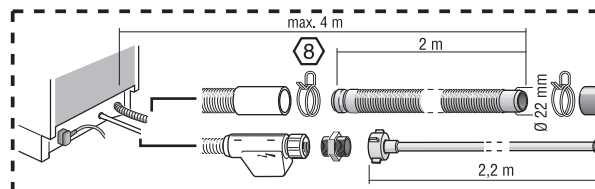

max. 4 m
2 m
Ø 22 mm
2,2 m

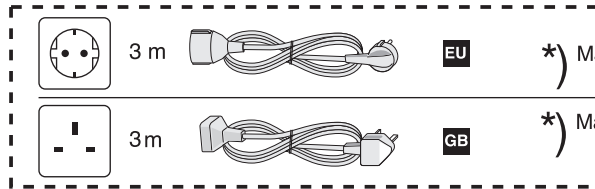

3 m EU
3 m GB

GB

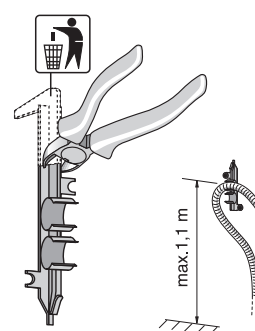

max. 1,1 m

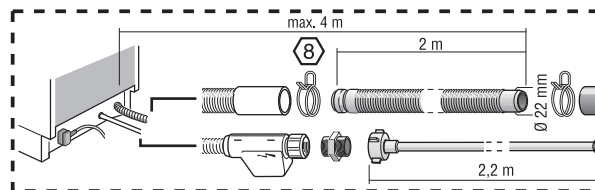

max. 4 m
2 m
Ø 22 mm
2,2 m

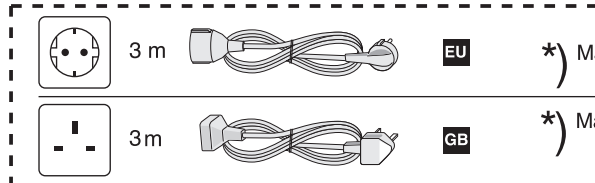

3 m EU
3 m GB

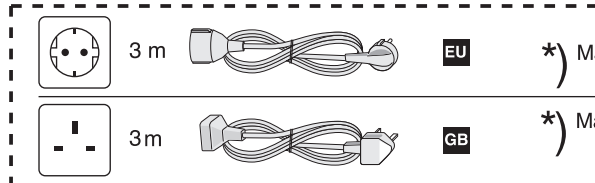

3 m EU
3 m GB

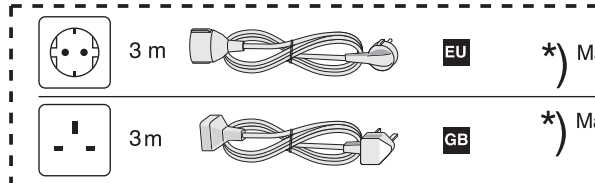

3 m EU
3 m GB

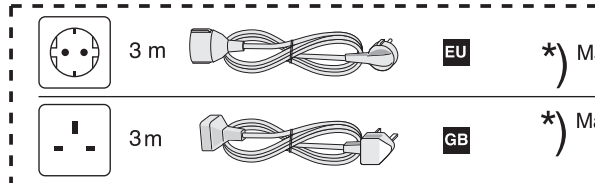

3 m EU
3 m GB