

**de** Montageanleitung  
 \*) über Kundendienst erhältlich  
**ca** Installation instructions  
 \*) Available from customer service  
**fr** Notice de montage  
 \*) Disponible par le biais du service après-vente  
**nl** Montagevoorschrift  
 \*) Tegen meerprijs bij de Servicedienst verkrijgbaar  
**it** Istruzioni per il montaggio  
 \*) Disponibili presso il servizio assistenza clienti  
**el** Οδηγίες συναρμολόγησης  
 \*) Διατίθεται από την υπηρεσία τεχνικής εξυπηρέτησης πελατών  
**es** Instrucciones de montaje \*) Se puede adquirir a través del Servicio de Asistencia Técnica Oficial de la marca  
**pt** Instruções de montagem \*) Pode ser adquirido nos nossos Serviços Técnicos  
**sv** Monteringsanvisning  
 \*) kan fås via Service

**tr** Montaj kılavuzu  
 \*) Yetkili servis üzerinden alınabilir  
**ru** Инструкция по монтажу  
 \*) Можно получить в сервисном центре  
**cs** Montážní návod  
 \*) K dispozici přes servisní službu  
**no** Monteringsanvisning  
 \*) fåes hos kundeservice  
**fi** Asennusohje  
 \*) Saatavissa huoltopalvelusta  
**da** Monteringsvejledning  
 \*) Kan købes hos serviceafdelingen  
**pl** Instrukcja montażu  
 \*) Do uzyskania w punkcie serwisowym  
**hu** Szerelési utasítás  
 \*) A vevőszolgálaton keresztül kapható:  
**hr** Uputa za montažu  
 \*) može dobiti kod službe održavanja

**mk** Упатство за монтажа  
 \*) се добива преку службата за купувачи  
**sl** Navodilo za montažo  
 \*) Lahko nabavite v servisni službi  
**sk** Uputstvo za montažu  
 \*) Može se nabaviti preko servisne službe  
**et** Monteerimisjuhend  
 \*) Küsige klientiteeninduselt  
**lt** Montavimo instrukcija  
 \*) Ją galima gauti klientų aptarnavimo servise  
**lv** Montāžas pamācība  
 \*) Var saņemt servisa dienestā  
**uk** Навод на монтаж  
 \*) Достанете в службі заклианком  
**cl** Udhuzues për montim  
 \*) Sigurohet nëpërmjet servisit  
**bs** Uputa za montažu  
 \*) Može se dobiti preko servisne službe

**fa** راهنمای مونتاژ  
 \*) از مرکز خدمات پس از فروش تهیه فرمایید  
**ar** تعليمات التركيب  
 \*) يمكن شتيها من مراكز خدمة العملاء  
**ko** 설치 설명서  
 \*) 고객센터 서비스 센터에서 구입 가능  
**zh** 安裝說明書  
 \*) 可向售後服務站索取  
**uk** Інструкція з монтажу  
 \*) Можна отримати через сервісну службу  
**ro** Instrucțiunile de montaj  
 \*) pot fi obținute la serviciul pentru clienți  
**id** Instruksi Pemasangan  
 \*) bisa didapatkan melalui Customer Service  
**kk** Іске қосу туралы нұсқаулар!  
 \*) Сервис қызмет көрсету орталығында алуға жағдай

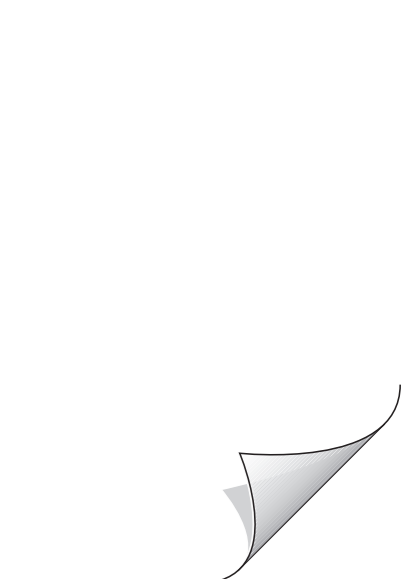
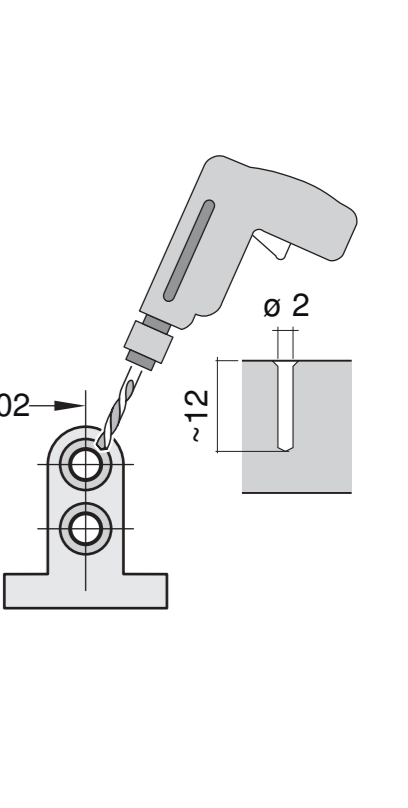
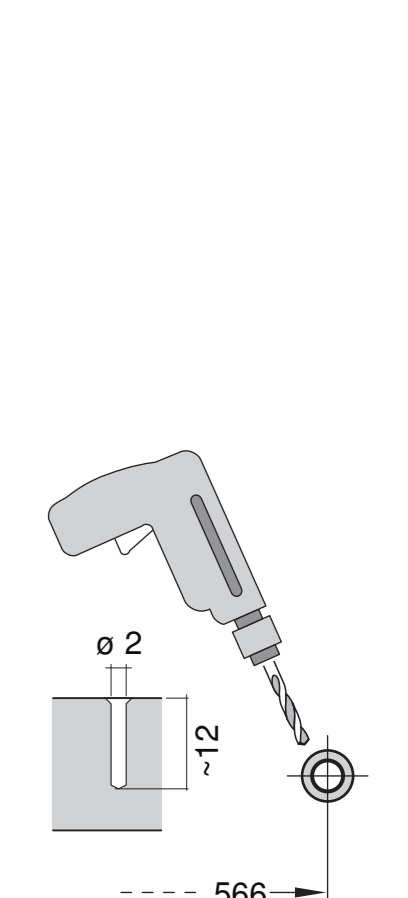
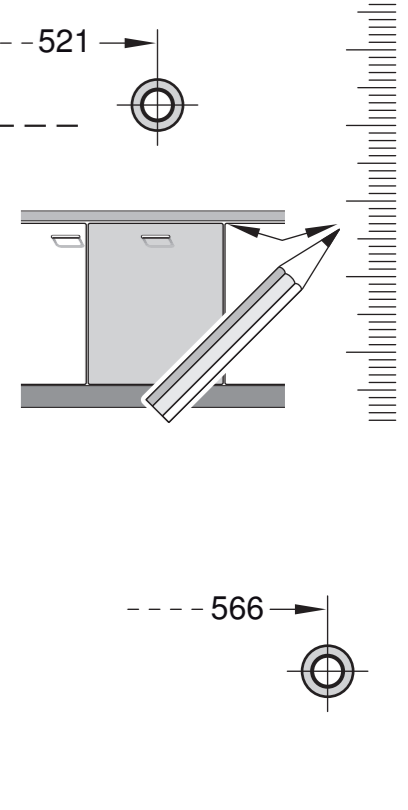
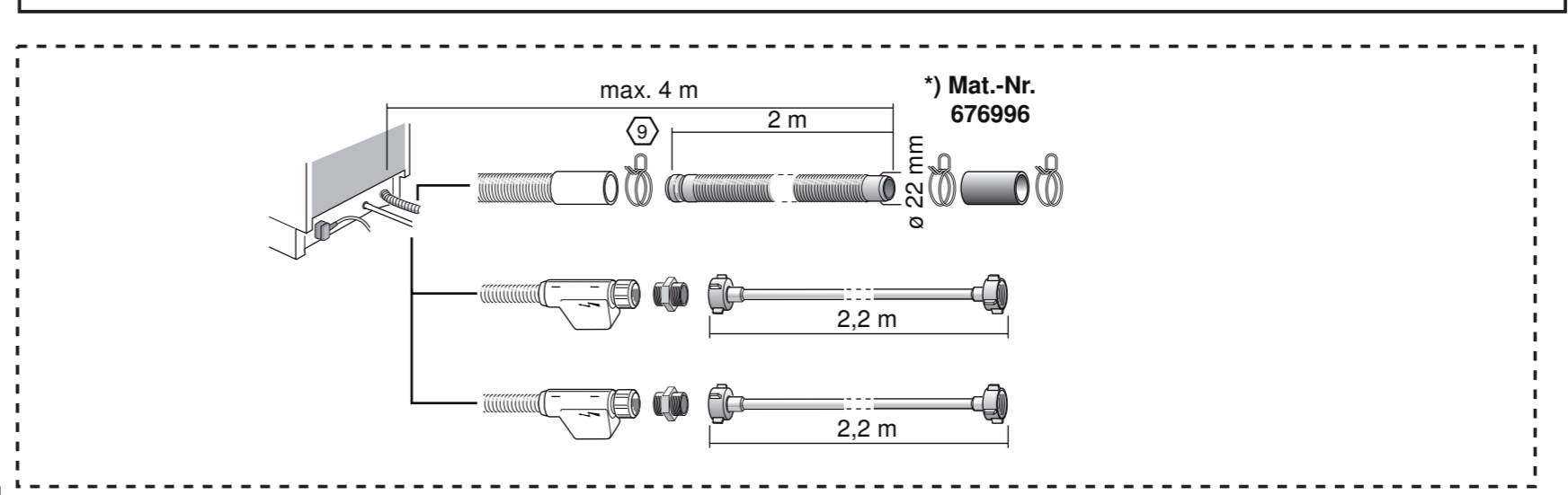
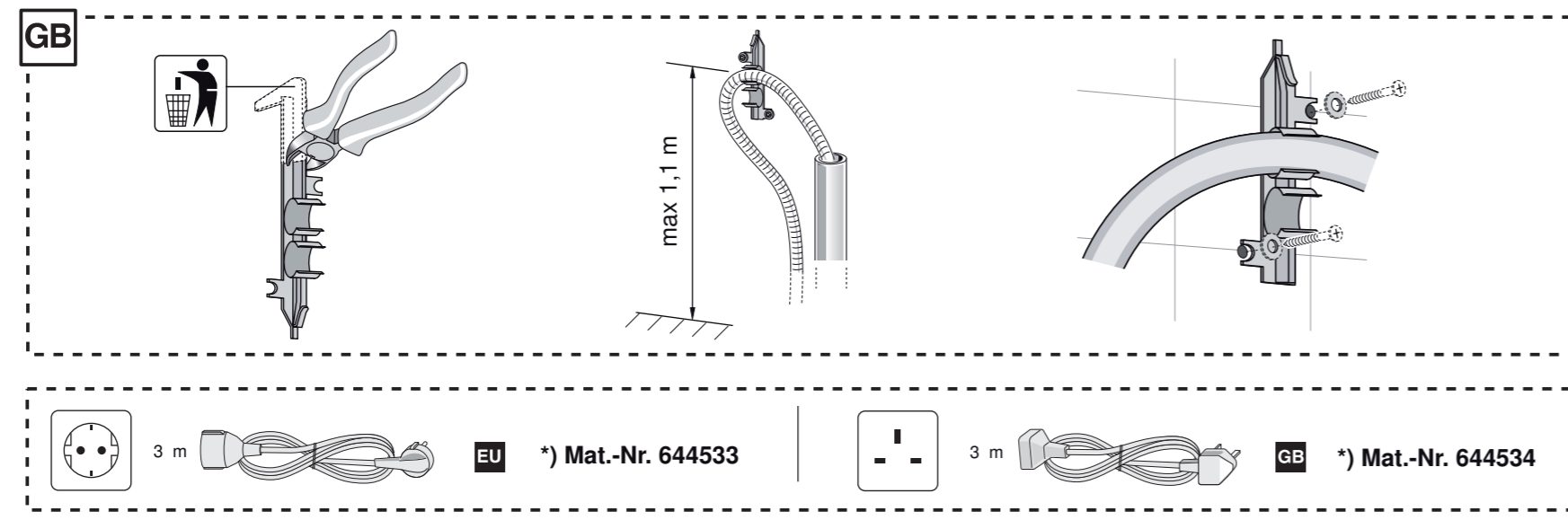
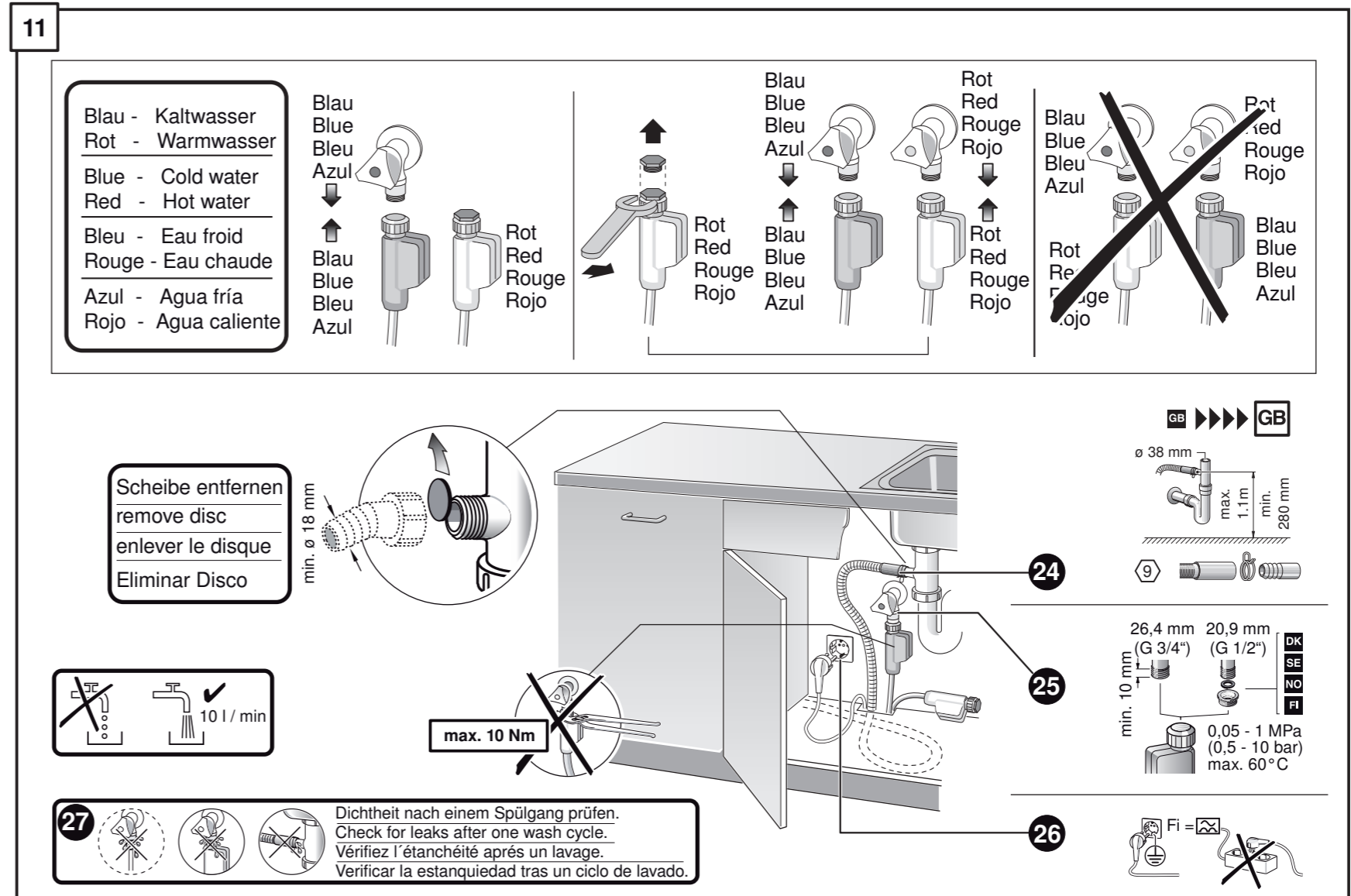
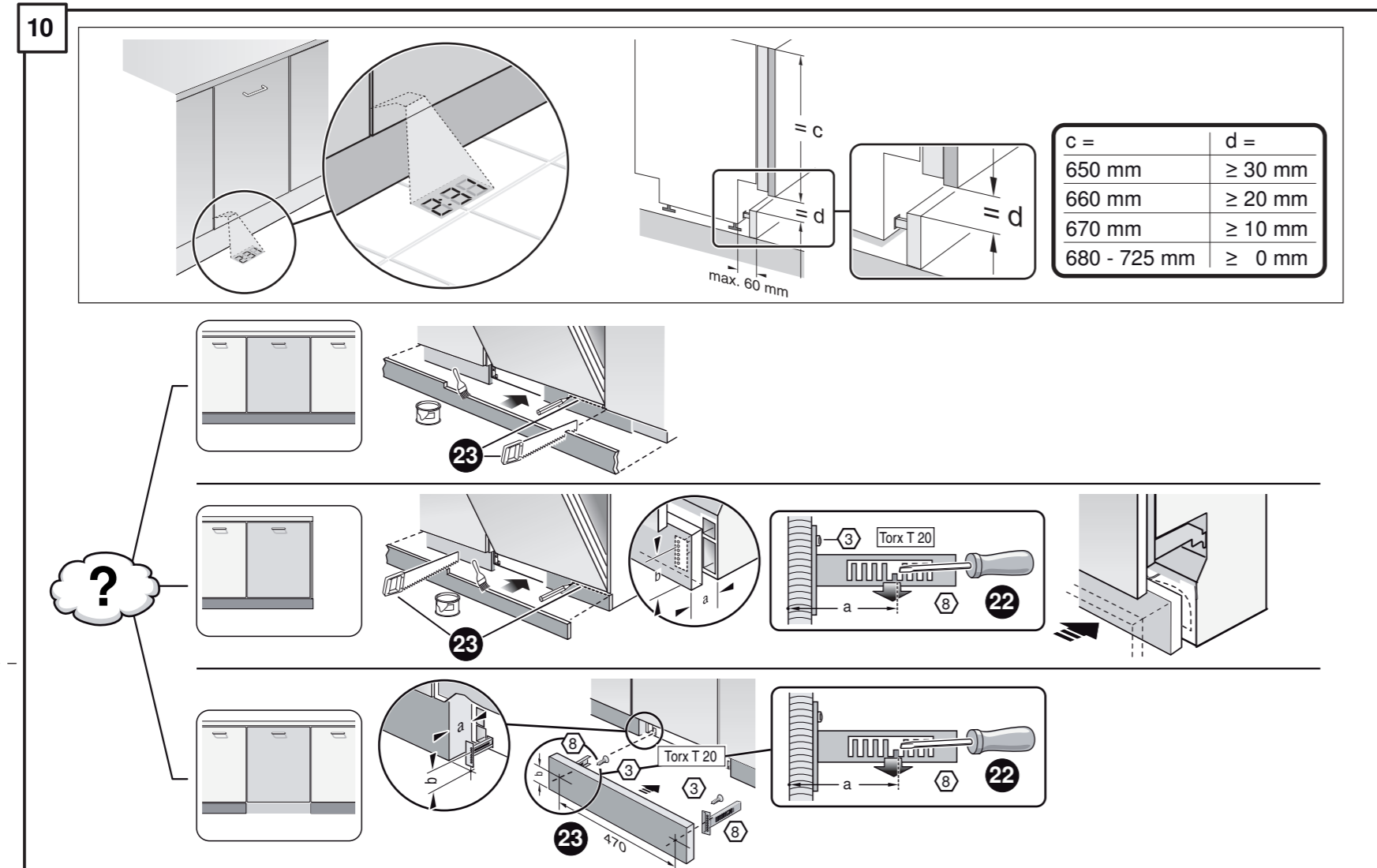
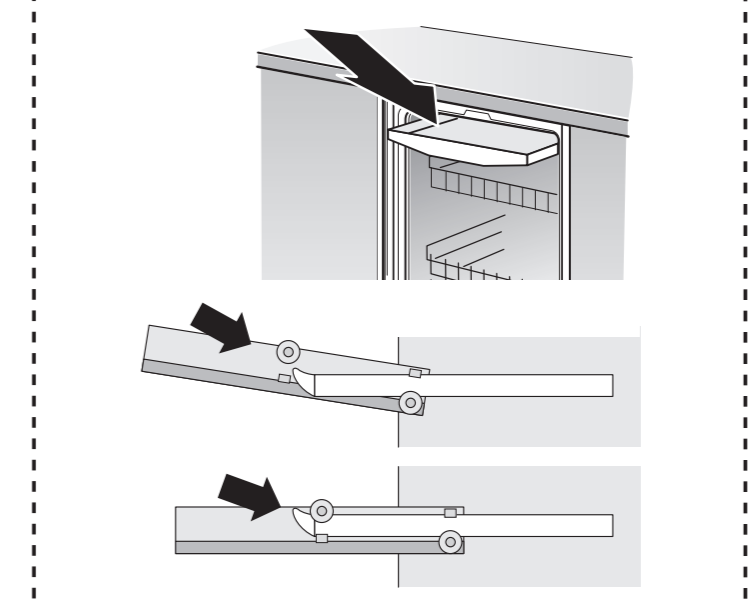
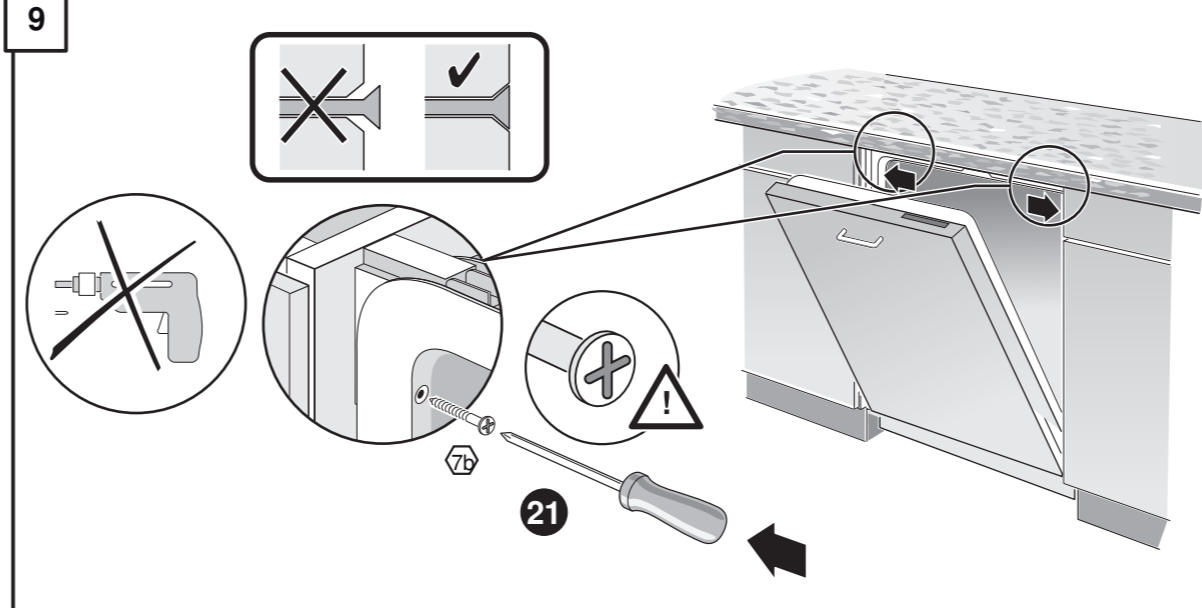
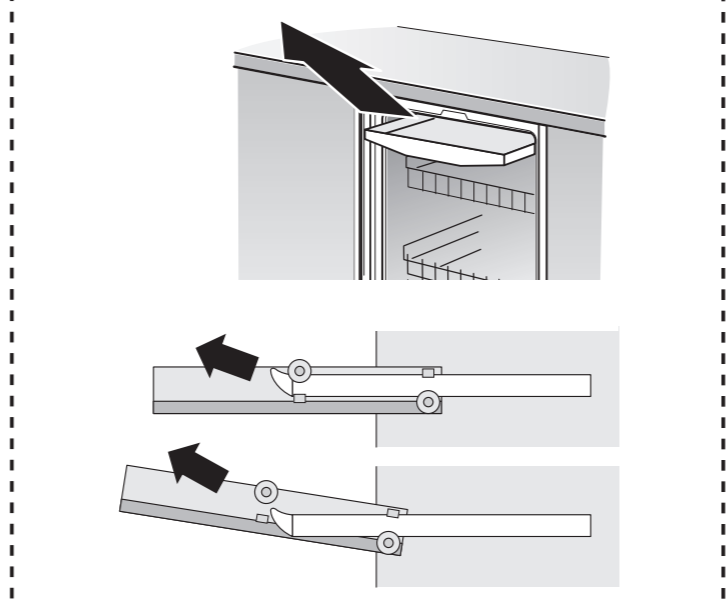
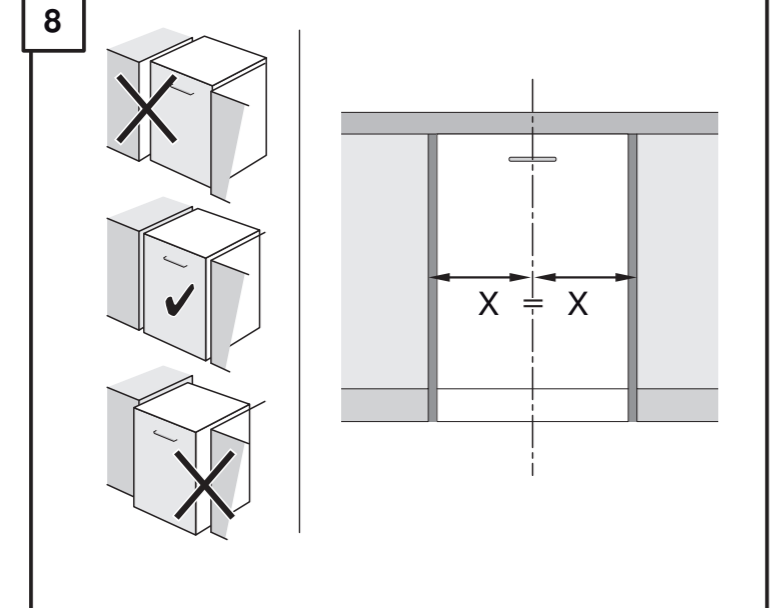
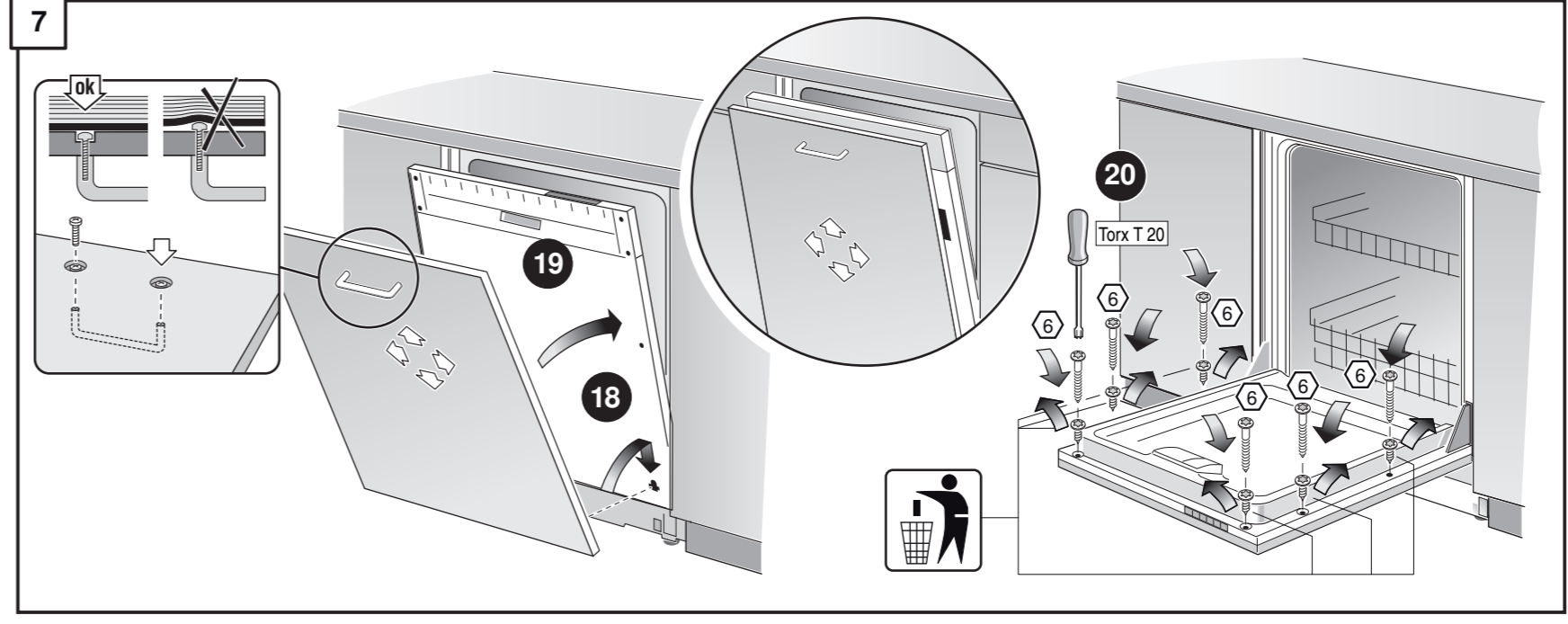
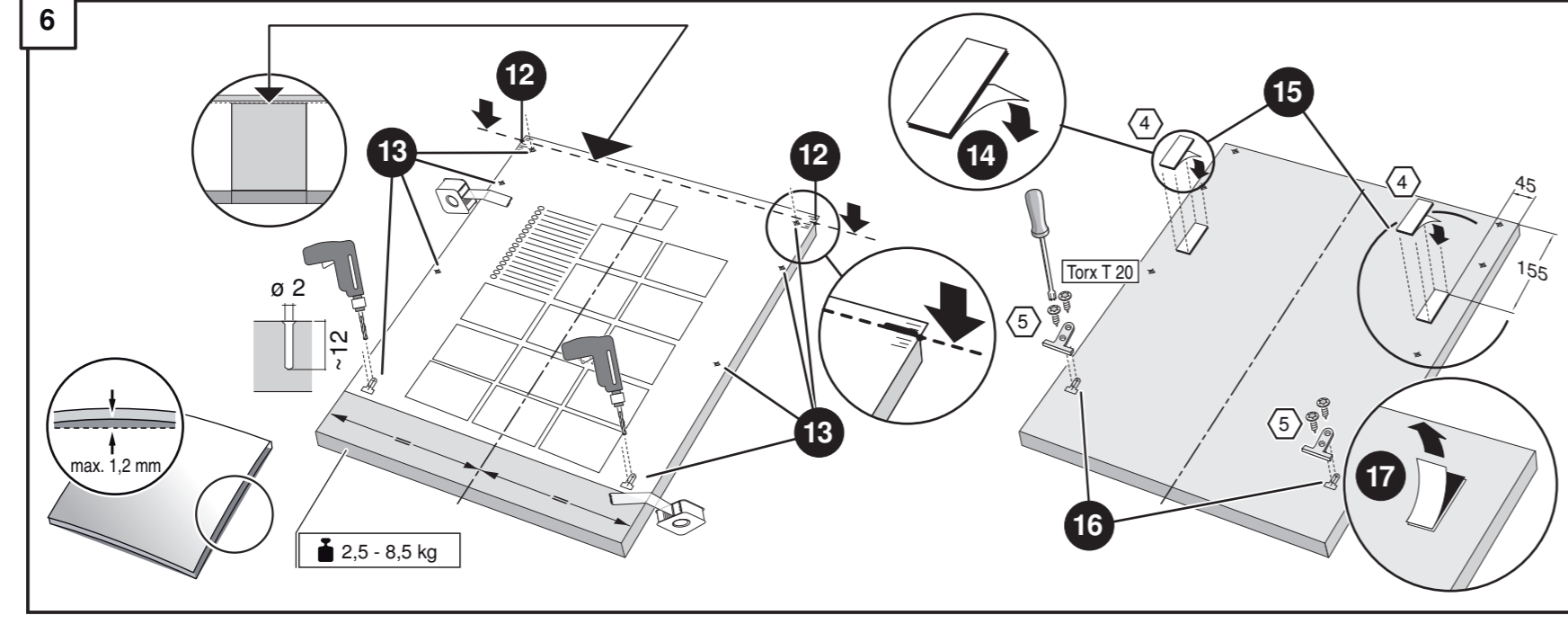
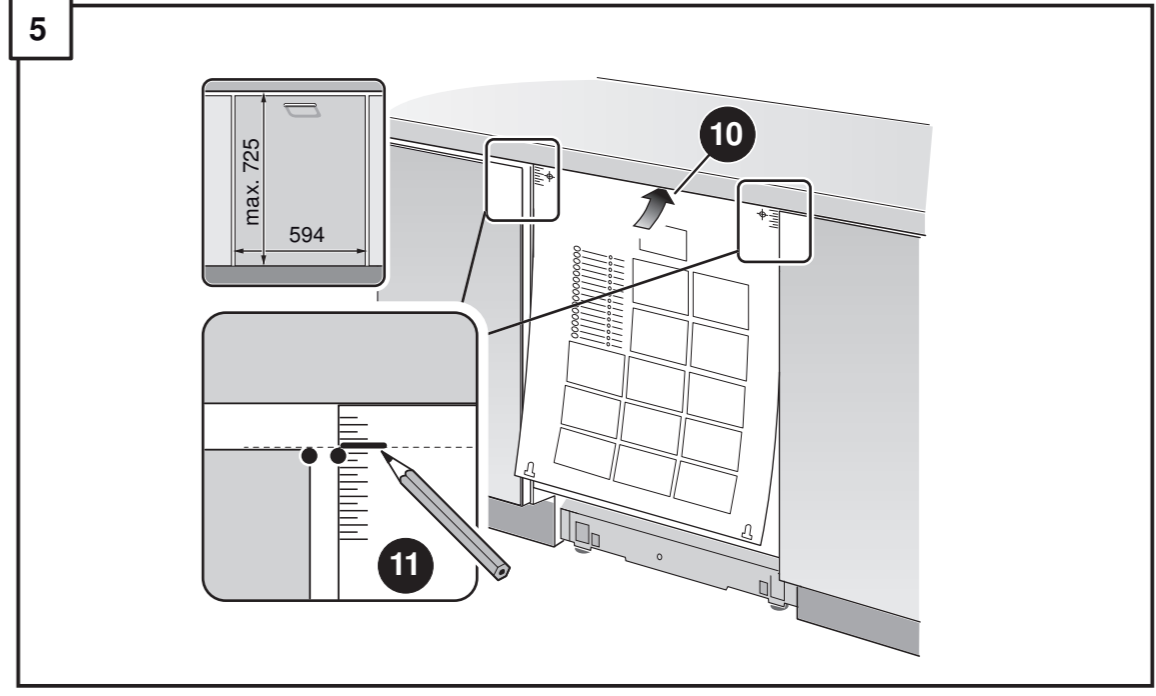
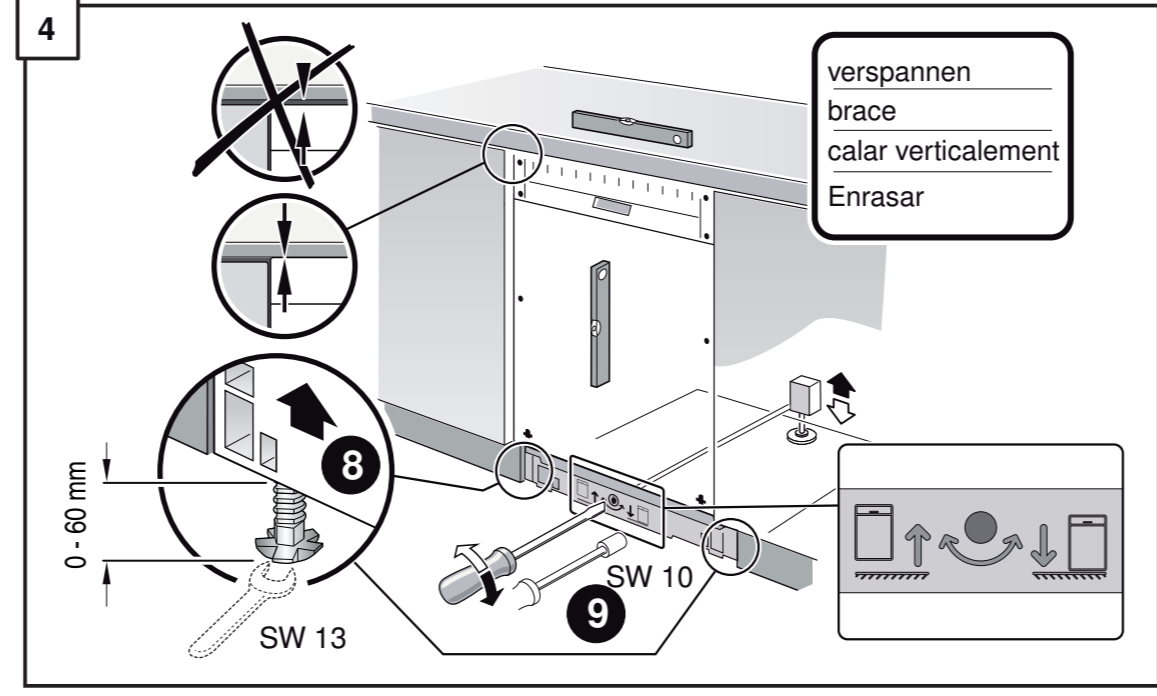
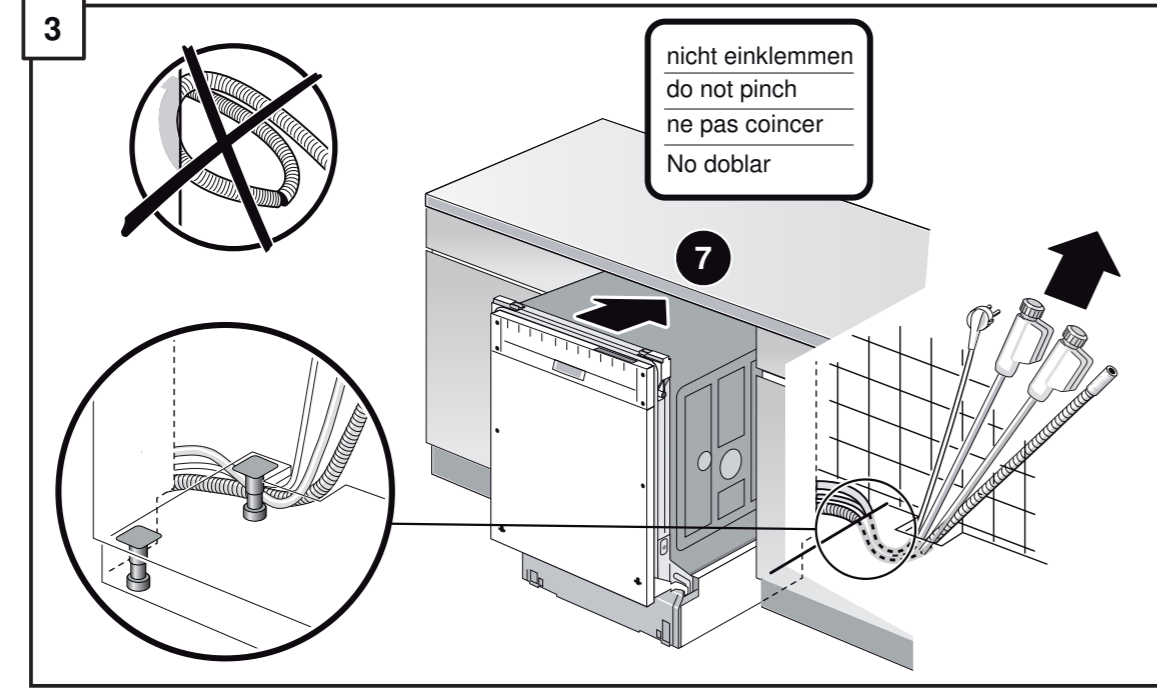
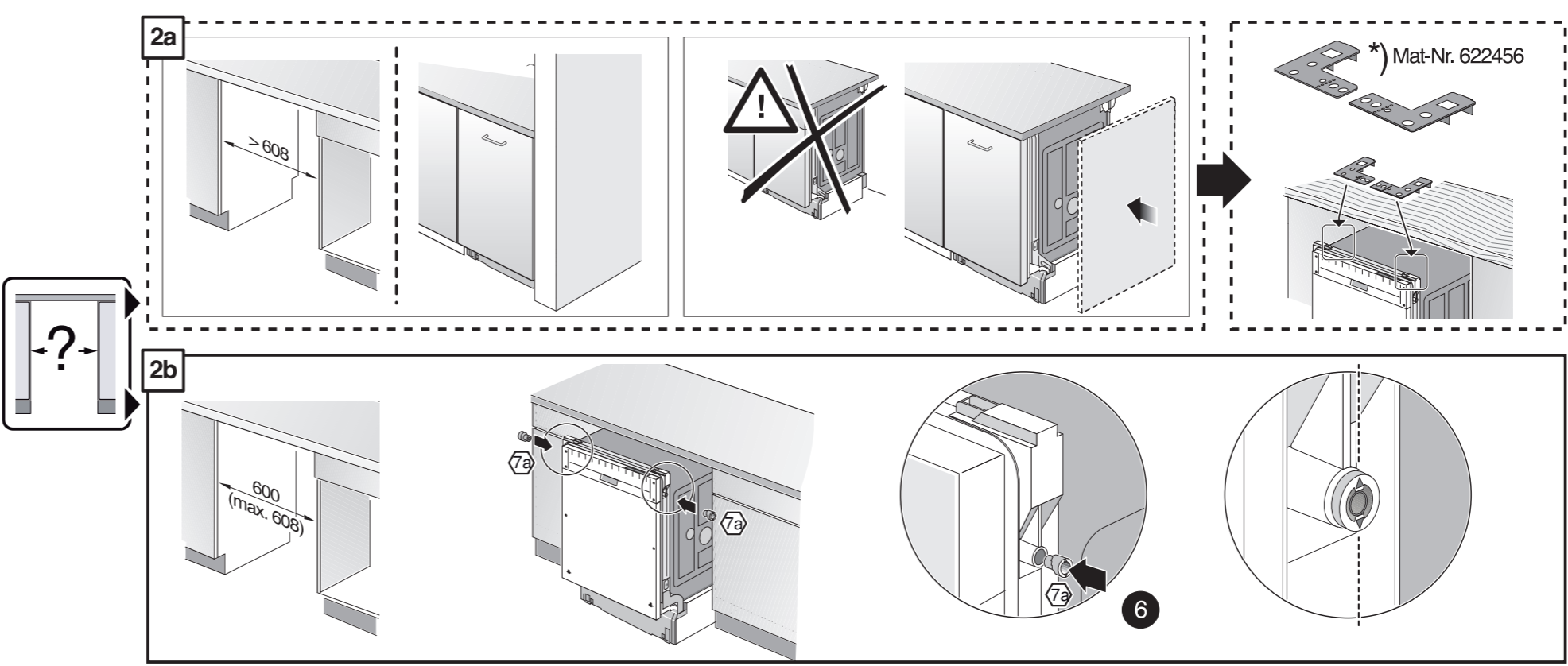
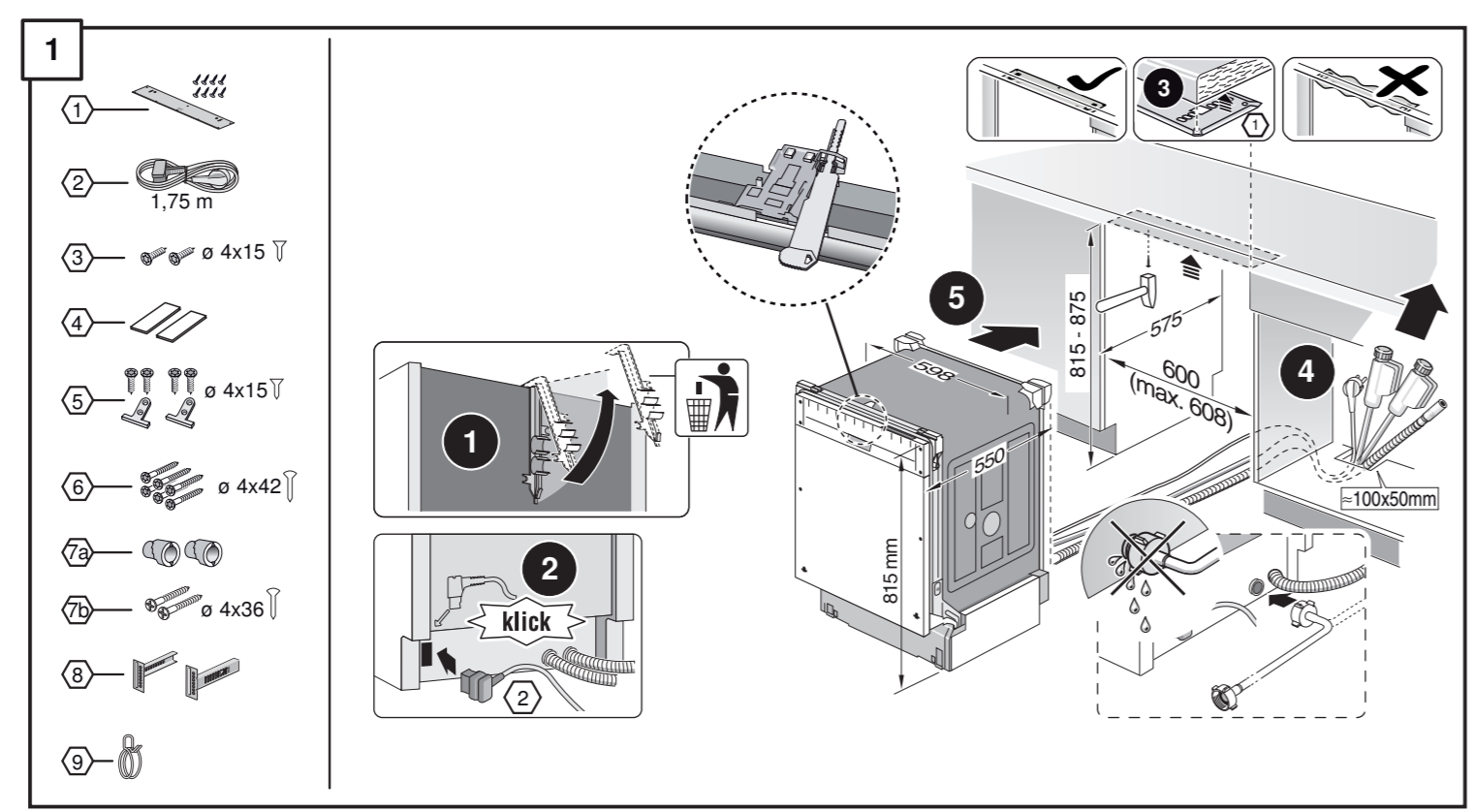
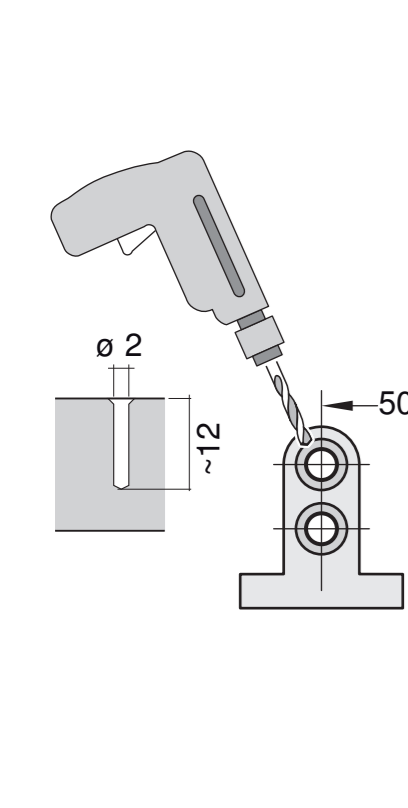
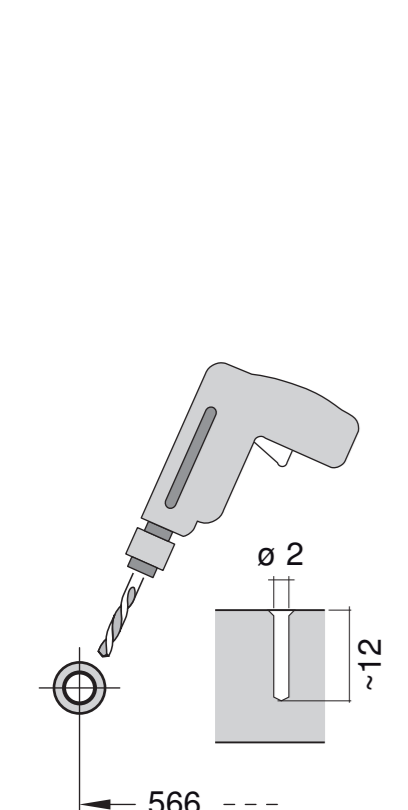
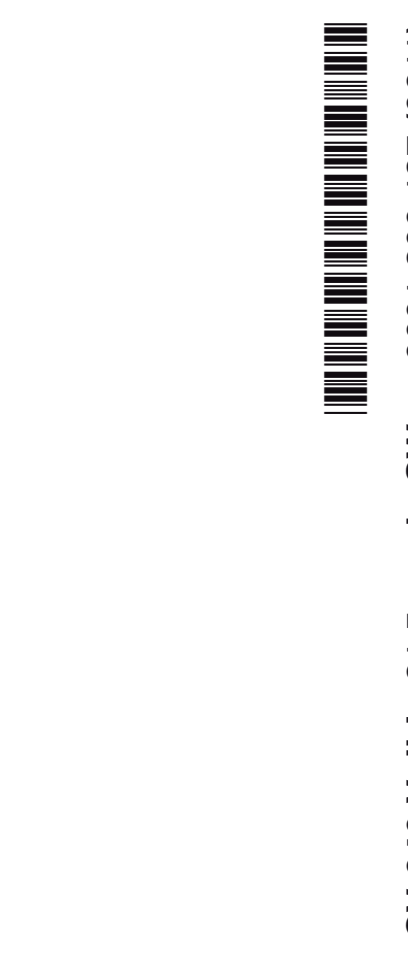

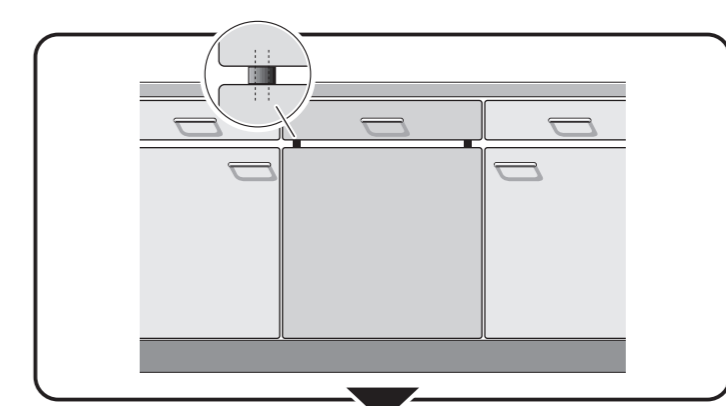
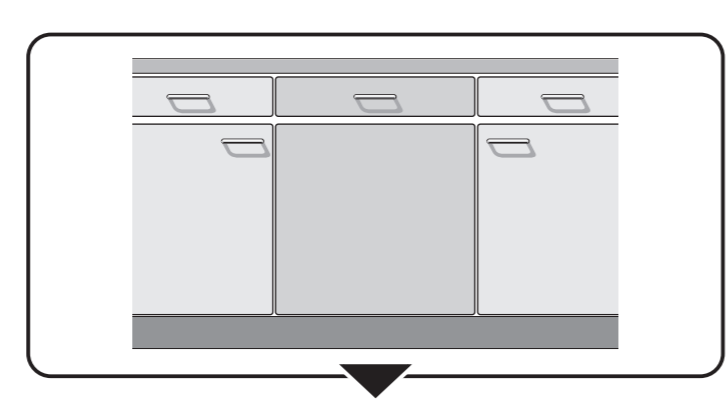
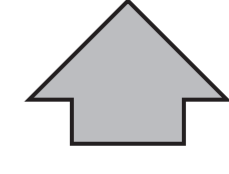
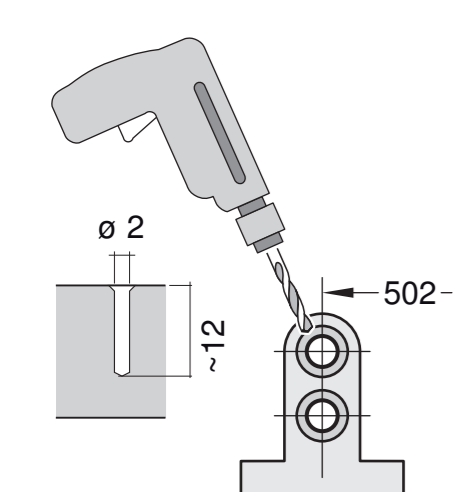
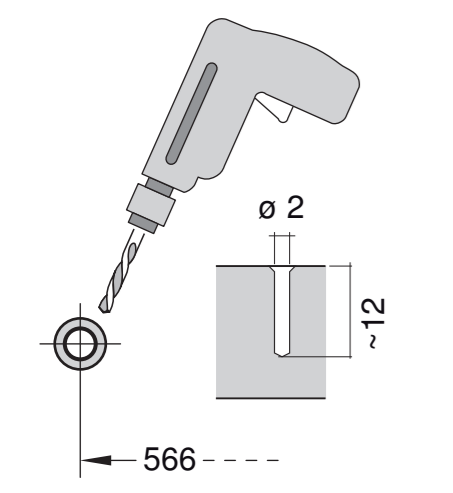
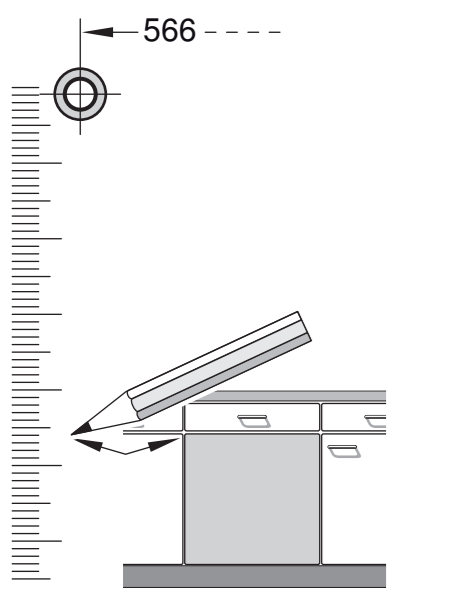
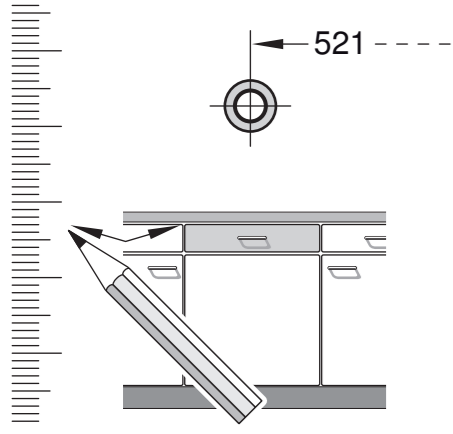

**1**

1) 1,75 m  
3)  $\phi$  4x15  
4)  
5)  $\phi$  4x15  
6)  $\phi$  4x42  
7)  $\phi$  4x36  
8)  
9)

1) **klück**

5) 615 - 675  
600 (max. 606)  
-100x50mm

**2a**

**2b**

Mat-Nr. 622456

**3**

nicht einklemmen  
do not pinch  
ne pas coincer  
No doblar

**4**

verspannen  
brace  
calar verticalment  
Enrasar

0 - 60 mm  
SW 13

**5**

max. 725  
594

**6**

Torx T 20

**7**

max. 1,2 mm  
Torx T 20  
2,5 - 8,5 kg

1  
4  
5a

**5a**

max. 725  
594

**6a**

2,5 - 8,5 kg  
Torx T 20  
12

**7a**

max. 1,2 mm  
Torx T 20  
23

8

**8**

X = X

**9**

24

**9**

24

**11**

24

**10**

c =  
d =  
max. 60 mm  
25  
26

650 mm	$\geq$ 30 mm
660 mm	$\geq$ 20 mm
670 mm	$\geq$ 10 mm
680 - 725 mm	$\geq$ 0 mm

**11**

Blau - Kaltwasser Rot - Warmwasser Blue - Cold water Red - Hot water Bleu - Eau froide Rouge - Eau chaude Azul - Agua fría Rojo - Agua caliente	Blau Blue Bleu Azul	Rot Red Rouge Rojo	Blau Blue Bleu Azul	Rot Red Rouge Rojo	Blau Blue Bleu Azul	Rot Red Rouge Rojo
--	------------------------------	-----------------------------	------------------------------	-----------------------------	------------------------------	-----------------------------

Scheibe entfernen  
remove disc  
enlever le disque  
Eliminar Disco

max. 10 Nm

Dichtheit nach einem Spülgang prüfen.  
Check for leaks after one wash cycle.  
Vérifiez l'étanchéité après un lavage.  
Verificar la estanquidad tras un ciclo de lavado.

27  
28  
29

30

**GB**

3 m  
Mat.-Nr. 644533  
3 m  
Mat.-Nr. 644534

**11**

max. 4 m  
2 m  
2,2 m  
2,2 m  
Mat.-Nr. 676996

