



Register your new Bosch now:
www.bosch-home.com/welcome



Gas hob
PBP6C.....



BOSCH

[en] Instruction manual

PBP6C.....

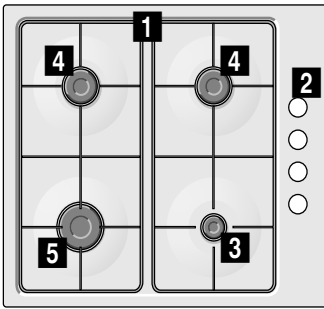

- 1** Pan supports
- 2** Control knobs
- 3** Auxiliary burner (up to 1 kW)

- 4** Semi-rapid burner (up to 1.75 kW)
- 5** Rapid burner (up to 3 kW)

Table of contents

Safety precautions	3	Cleaning.....	9
Causes of damage	5	Maintenance	10
Your new appliance	6	Trouble shooting	10
Rotary knob for the gas burner.....	6	After-sales service	11
Pan rest for the economy burner (option):.....	6	E number and FD number	11
Before first use	6	Packaging and equipment used	11
Cleaning the accessories.....	6	Environmentally-friendly disposal.....	11
Advance cleaning of burner cup and cap	6	Energy-saving tips.....	11
Making settings on the hob	7	Measures to be noted during transport.....	11
Igniting the gas burners.....	7		
Cookware and cooking recommendations	7		
Suitable pans.....	7		
Precautions for use	8		
Table - Cooking.....	8		
Cleaning and maintenance	9		

Additional information on products, accessories, replacement parts and services can be found at www.bosch-home.com and in the online shop www.bosch-eshop.com

Safety precautions

Please read this manual carefully. Please keep the instruction and installation manual as well as the appliance certificate in a safe place for later use or for subsequent owners.

The manufacturer is exempt from all responsibility if the requirements of this manual are not complied with.

This appliance is class 3 type, according to the EN 30-1-1 regulation for gas appliances: built-in appliance.

Appliance's type of approval: HIGVS6RQ00

The graphics in this instruction manual are given as a guide only.

Do not remove the appliance from its protective packaging until it is installed in the unit.

Check the appliance for damage after unpacking it. Do not connect the appliance if it has been damaged in transport.

Caution:The use of a gas cooking appliance results in the production of heat, moisture and products of combustion in the room in which it is installed. Ensure that the kitchen is well ventilated especially when the appliance is in use: keep natural ventilation holes open or install a mechanical ventilation device (mechanical extractor hood).

Prolonged intensive use of the appliance may call for additional ventilation, for example opening of a window, or more effective ventilation, for example increasing

the level of mechanical ventilation where present.

This appliance can only be installed in a well-ventilated place in accordance with existing regulations and ventilation specifications. The appliance must not be connected to a combustion product removal device.

The place in which the appliance is installed must have fully-functioning ventilation, in accordance with the regulations.

This appliance must be installed according to the installation instructions included.

Only allow a licensed professional to connect the appliance and to convert the appliance to a different type of gas. The appliance must be installed (electric and gas connections) in accordance with the instruction and installation manual. An incorrect connection or incorrect settings may lead to serious accidents and damage to the appliance. The appliance manufacturer accepts no liability for damage of this kind. The appliance's warranty becomes void.

This appliance has been designed for home use only, not for commercial or professional use. This appliance cannot be installed on yachts or in caravans. The warranty will only be valid if the appliance is used for the purpose for which it was designed.

This appliance is intended for domestic use and the household environment only. This appliance must only be used to prepare

food and drinks and must never be used as a heater. Do not leave the appliance unattended during operation. Only use the appliance indoors.

This appliance is intended for use up to a maximum height of 2000 metres above sea level.

This appliance is not intended for operation with an external clock timer or a remote control.

Never leave the appliance unattended during operation.

This appliance may be used by children 8 years old and older and by persons with reduced physical, sensory or mental capacity or a lack of experience or knowledge if they are supervised or they have been instructed about the safe use of the appliance and have understood the associated dangers.

Never let children play with the appliance. Cleaning and user maintenance must not be carried out by unsupervised children.

Risk of poisoning!

The kitchen will become hot and humid and combustion products produced when this gas appliance is used. Make sure the kitchen is well ventilated, particularly when the hob is in operation: either keep the natural ventilation apertures open, or install a ventilation system (extractor hood). Intense prolonged use of the appliance may require additional or more effective ventilation: open a window or increase the power of the ventilation system.

Risk of deflagration!

- Accumulation of unburned gas in an enclosed area carries a risk of deflagration. Do not subject the appliance to draughts. These might blow out the burners. Carefully read the instructions and warnings on the operation of gas burners.
- Hot oil and fat can ignite very quickly. Never leave hot fat or oil unattended. Never use water to put out burning oil or fat. Switch off the hotplate. Extinguish flames carefully using a lid, fire blanket or something similar.
- When gas hotplates are in operation without any cookware placed on them, they can build up a lot of heat. The appliance and the extractor hood above it may become damaged or be set on fire. Grease residue in the filter of the extractor

hood may ignite. Only operate the gas burners with cookware on them.

- The hotplates become very hot. Never place combustible items on the hob. Never place objects on the hob.
- The appliance becomes very hot, and flammable materials can easily catch fire. Do not store or use any flammable objects (e.g. aerosol cans, cleaning agents) under or in the vicinity of the oven. Do not store any flammable objects inside or on top of the oven.
- The rear of the appliance becomes very hot. This may cause damage to the power cables. Electricity and gas lines must not come into contact with the rear of the appliance.

Risk of burns!

- The hotplates and surrounding area (particularly the hob surround, if fitted) become very hot. Never touch the hot surfaces. Keep children at a safe distance.
- During operation, the surfaces of the appliance become hot. Do not touch the surfaces when they are hot. Keep children away from the appliance.
- The alcoholic vapours may catch fire on the hot cooking surface. Never prepare food containing large quantities of drinks with a high alcohol content. Only use low percentage alcohol.
- Empty cookware becomes extremely hot when set on a gas hotplate that is in operation. Never heat up empty cookware.
- Metal objects on the hob quickly become very hot. Never place metal objects (such as knives, forks, spoons and lids) on the hob.
- If the liquefied gas bottle is not upright, liquefied propane/butane can enter the appliance. Intense darting flames may therefore escape from the burners. Components may become damaged and start to leak over time so that gas escapes uncontrollably. Both can cause burns. Always use liquefied gas bottles in an upright position.
- The appliance becomes hot during operation. Allow the appliance to cool down before cleaning.

Risk of injury!

- Incorrect repairs are dangerous. Repairs may only be carried out, and damaged power and gas lines replaced, by an after-sales engineer trained by us. If the appliance is faulty, unplug the mains plug or switch off the fuse in the fuse box. Shut off the gas supply. Contact the after-sales service.
- Faults or damage to the appliance are dangerous. Never switch on a faulty appliance. Unplug the appliance from the mains or switch off the circuit breaker in the fuse box. Shut off the gas supply. Contact the after-sales service.
- Unsuitable pan sizes, damaged or incorrectly positioned pans can cause serious injury. Observe the instructions which accompany the cookware.

Risk of electric shock!

- Incorrect repairs are dangerous. Repairs may only be carried out by one of our trained after-sales engineers. If the appliance is faulty, unplug the mains plug or switch off the fuse in the fuse box. Contact the after-sales service.
- The cable insulation on electrical appliances may melt when touching hot

parts of the appliance. Never bring electrical appliance cables into contact with hot parts of the appliance.

- Do not use any high-pressure cleaners or steam cleaners, which can result in an electric shock.
- A defective appliance may cause electric shock. Never switch on a defective appliance. Unplug the appliance from the mains or switch off the circuit breaker in the fuse box. Contact the after-sales service.

Do not subject the appliance to draughts. These might blow out the burners.

Do not tamper with the appliance's interior. If necessary, call our Technical Assistance Service.

If one of the control knobs will not turn, do not force it. Call the Technical Assistance Service immediately, so that they can repair or replace it.

Do not use inappropriate child safety shields or hob guards. These can cause accidents.

Causes of damage

Hob

Caution!

Only use the burners when cookware has been placed on top. Do not heat up empty pots or pans. The saucepan base will be damaged.

Caution!

Only use pots and pans with an even base.

Caution!

Place the pot or pan centrally over the burner. This will optimise transfer of the heat from the burner flame to the pot or pan base. The handle does not become damaged, and greater energy savings are guaranteed.

Caution!

Ensure that the hob gas burners are clean and dry at all times. The burner cup and burner cap must be positioned exactly.

* **Option:** Only valid for some models.

Caution!

Ensure that the top cover is not closed when the oven is started up.

Caution!

If you are using the appliance with a gas cylinder, the cylinder must be stood upright. Using the gas cylinder horizontally can damage your appliance's interior components and cause a gas leak.

Caution!

The area around the appliance must be clean and dry.

Always keep the appliance and the area around it clean and dry after cleaning.

Make sure that there are no cleaning materials, cleaning products or water marks on any of the appliance's surfaces.

Your new appliance

Page 2 shows an overall view of your new appliance as well as the burner power.

Rotary knob for the gas burner

There are indications to show which burner each control knob operates.

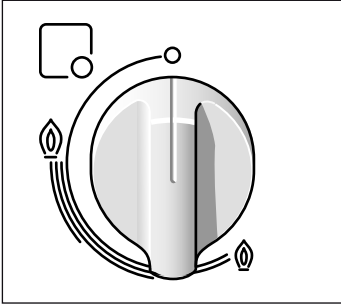

It is essential to ensure that all the burner parts and pan supports are correctly installed for the appliance to work correctly. Do not swap the burner caps around.

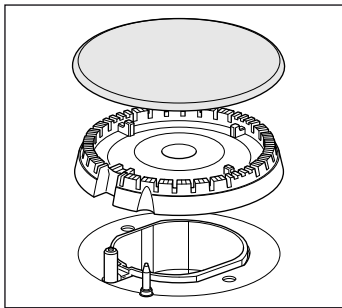

Power levels

The progressive control knobs can be used to control the power needed, from minimum to maximum power.

Setting		Control knob off
High flame		Maximum capacity or aperture and electricity on
Low flame		Minimum capacity or aperture

Pan rest for the economy burner (option):

Use the pan rest supplied with the appliance when you use the economy burner to prepare dishes using small saucepans with a diameter of less than 12 cm or Turkish coffee using a small espresso jug.

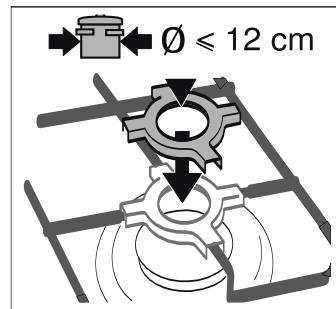

Place the pan rest on the economy burner's steel grid.

Do not use the pan rest for saucepans with a diameter of more than 12 cm.

The pan rest must only be used on the economy burner.

Before first use

The things you should note before first use are detailed below. First read the *Safety Precautions* section.

Cleaning the accessories

Before you use the accessories for the first time, clean them thoroughly with hot soapy water and a soft dish cloth.

Advance cleaning of burner cup and cap

Clean the burner cap (1) and burner cup (2) with water and washing-up liquid. Dry the individual parts carefully.

Place the burner cup and cap back on the burner shell (5). Ensure that the igniter (3) and flame safety pin (4) are not damaged.

The nozzle (6) must be dry and clean. Always position the burner cap exactly over the burner cup.

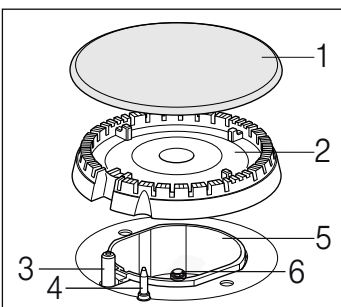

Making settings on the hob

Your hob is equipped with four gas burners. The following information explains how to light the gas burners and set the size of flame.

Igniting the gas burners

Ensure that the burner lid always sits on the burner cup correctly. The slots on the burner cup must not be blocked. All parts must be dry.

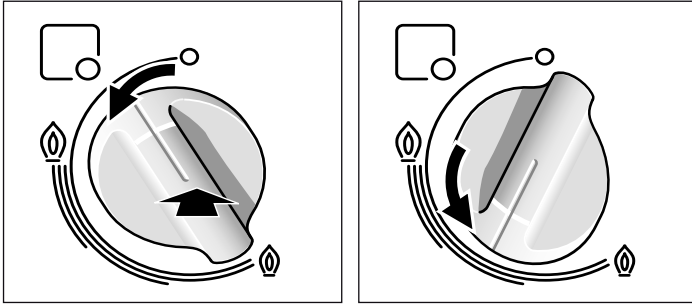

1. Press the burner knob of the selected burner in and turn it anti-clockwise to the highest power level. When the burner knob is pressed, the ignition process starts.
2. Press and hold the burner knob for 3-5 seconds. Gas begins to flow out and the gas burner ignites.
The safety pilot is activated. If the gas flame goes out, the gas supply is automatically cut off by the safety pilot.
3. Set the required flame height. The flame is not stable between the Off position and the highest power level. For this reason, you should always select a setting between the highest and lowest power level.
4. If the flame goes out again, repeat the process from step 1.
5. To finish cooking, turn the burner knob clockwise to the Off position.

The burner knob should not be pressed in the ignition position for longer than 15 seconds. If the burner does not ignite within 15 seconds, wait at least one minute. Then repeat the ignition process.

⚠ Caution!

If, after switching the gas hob off, you turn the burner knob while the gas hob is still hot, gas will escape. If you do not press the burner knob, the gas is not ignited and the gas supply is interrupted within 90 seconds.

No ignition occurs

If there is a power cut or if the ignition plugs are damp, you can light the gas burners with a gas lighter or a match.

Warnings

It is normal to hear a soft whistling noise while the burner is operating.

When first used, it is normal for the burner to give off odours. This does not pose any risk and does not indicate a malfunction. They will disappear in time.

An orange-coloured flame is normal. This is caused by the presence of dust in the atmosphere, spilt liquids, etc.

If the burner flames are accidentally blown out, switch off the burner operating control knob and do not try to relight it for at least 1 minute.

A few seconds after the burner is switched off, a sound (thud) will be produced. This is not a fault - this means that the safety device is no longer operating.

Keep the burner as clean as possible. If the ignition sparkers are dirty they will not light properly. Clean them periodically using a small non-wire brush. Bear in mind that the ignition sparkers must not suffer any serious impacts.

Cookware and cooking recommendations

Suitable pans

Burner	Minimum diameter of the cookware base	Maximum diameter of the cookware base
Wok burner	24 cm	- cm
High-output burner	22 cm	26 cm
Standard-output burner	14 cm	20 cm
Economy burner	12 cm	16 cm

The cookware must not overhang the edge of the hob.

Precautions for use

The following advice is intended to help you save energy and prevent pan damage:

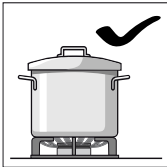

Use pans which are the right size for each burner.
Do not use small pans on large burners. The flame must not touch the sides of the pan.

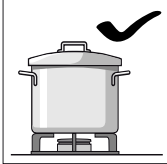

Do not use damaged pans, which do not sit evenly on the hob. Pans may tip over.
Only use pans with a thick, flat base.

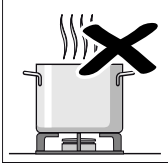
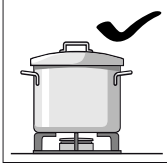

Do not cook without using a lid and make sure the lid is properly fitted. This wastes energy.

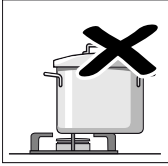
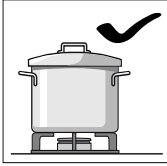

Always place the ovenware centrally over the burner. Otherwise, there is a risk that it may tip over.

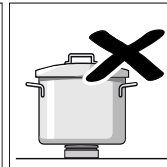
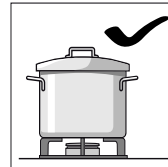

Place the pans on the pan supports, never directly on the burner.

Make sure that the pan supports and burner caps are correctly positioned before using the appliance.

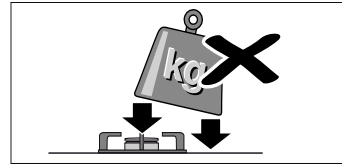

Pans should be placed on the hob carefully.

Do not strike the hob and do not place excessive weight on it.

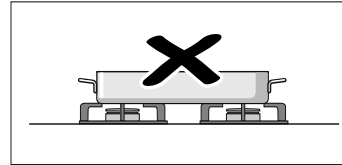

Never use two burners or heat sources to heat one single pan.

Do not use grill pans, earthenware casserole dishes, etc. for a long period of time on maximum power.

Table - Cooking

Select the right saucepan size for each burner. The diameter of the saucepan or pan base should be the same as that of the burner.

Cooking times may vary depending on the type of food, its weight and quality. You yourself can best judge the optimal cooking time.

Use as little water as possible when cooking, so that the food retains its vitamins and minerals. Select short cooking times so that the vegetables remain firm and full of nutrients.

Example	Food	Cooking position	Heat setting
Melting	Chocolate, butter, margarine	Economy burner	small flame
		Electric hotplate**	1-2
Warming	Stock, tinned vegetables	Standard burner	small flame
		Electric hotplate**	2-3-4-5
Heating and keeping warm	Soups	Economy burner	small flame
		Electric hotplate**	2-3
Steaming*	Fish	Standard burner	between large and small flame
		Electric hotplate**	5
Braising*	Potatoes and miscellaneous vegetables, meat	Standard burner	between large and small flame
		Electric hotplate**	6-7-8
Boiling*	Rice, vegetables, meat dishes (with sauces)	Standard burner	large flame
		Electric hotplate**	7-8
Frying	Pancakes, potatoes, schnitzel, fish fingers	Large burner	between large and small flame
		Wok burner	between large and small flame
		Electric hotplate**	9

* If you are using a saucepan with a lid, turn the flame down as soon as it reaches boiling point.

** Optional. Available for some appliances, depending on the appliance model (for frying on the wok burner, we recommend that you use a wok).

Cleaning and maintenance

For the cooking area to have optimum power and a long service life, thorough cleaning and maintenance are essential.

As a safety precaution, turn the gas off at the gas cylinder controller. (If the cooker is set up to use natural gas, close the natural gas tap).

Unplug the appliance from the mains.

If the burner is still hot, let it cool down first.

Caution!

- Do not use any high-pressure cleaners or steam jets.
- When cleaning the cooker, do not use any flammable substances such as acids, diluting agents, petrol or benzene.
- Under no circumstance should abrasive cleaning products or materials be used, which may cause scratches.

Cleaning

Damage to the various different surfaces caused by using the wrong cleaning agent can be avoided by observing the following instructions.

When cleaning the hob do not use

- undiluted washing-up liquid or dishwasher detergent,
- cleaning agent with a high alcohol content,
- scouring pads,
- abrasive cleaning agents such as oven cleaner or stain remover,
- Do not use caustic or abrasive cleaning agents.
- Do not clean individual parts in the dishwasher.

Wash new sponges thoroughly before first use.

Stainless steel surfaces* (depending on the appliance model)	Clean it with stainless-steel cleaning agent and a soft cloth. Always wipe stainless steel surfaces parallel to the natural grain. Otherwise, you may scratch the surface. Dry with a soft cloth. Always remove any flecks of limescale, grease, starch and egg white immediately. Harsh cleaning products, scratchy sponges and rough cleaning cloths are not suitable. You can use special care products to polish the stainless steel fronts. Follow the manufacturer's instructions. Special stainless-steel cleaning agents are available from the after-sales service or from specialist retailers.
Enamelled, painted and silkscreen surfaces* (depending on the appliance model)	Wipe with warm soapy water and a cloth. Dry with a soft cloth.
Gas burner and steel grid	Do not clean in the dishwasher. Remove the steel grid and clean this using a sponge, some hot water and washing-up liquid. Remove the burner casing and burner cap. Use a sponge with some hot water and washing-up liquid to clean these. Ensure that the gas openings on the burner casing are clean and free from dirt particles. Clean the igniter with a small, soft brush. The gas burners only work properly when the igniters are clean. Use a cloth and some hot soapy water to remove the food remains from the burner casing. Only use a little water for this. Water must not get into the interior of the appliance. Ensure that the jet opening is not blocked or damaged during the cleaning process. Dry all of the parts after they are cleaned, and place the burner caps exactly onto the burner casings. Individual parts that are not correctly positioned make it difficult for the burner to ignite. Place the steel grid back into its position. The cleaning agent that we recommend for cleaning the steel grid is available from our after-sales service or specialist retailers.
Glass hob* (depending on the appliance model)	Care: Protective/care products for glass Cleaning: Cleaning agents for glass. Follow the cleaning instructions on the packaging.  Glass scraper for heavy soiling: Remove the protective cover and clean using the blade only. Caution, the blade is very sharp. Risk of injury. Cover the blade again after cleaning. Replace damaged blades immediately.
Electric hotplate* (depending on the appliance model)	Clean with the hard side of a scouring sponge and some liquid scouring agent. After cleaning, switch the hob on briefly to dry it. Wet hobs rust over time. Then apply a care product. Always remove spilt liquids and food residue immediately.
Metal hotplate ring* (depending on the appliance model)	The metal ring may discolour with time. However, the original colour can be restored. Clean the ring with the hard side of a scouring sponge and some liquid scouring agent. Do not touch the adjacent surfaces. These may become damaged. The recommended cleaning agent for the metal ring on the electric hotplate is available from our after-sales service or specialist retailers
Rotary knobs	Wipe with warm soapy water and a cloth. Dry with a soft cloth.
Accessories	Soak in warm soapy water. Use a non-metal brush or a sponge to clean it.
Upper glass cover* (depending on the appliance model)	Glass cleaner: Clean with a soft cloth. You can remove the upper glass cover for cleaning. To find out how to do this, please refer to the section <i>Upper glass cover</i> .

* Optional (available for some appliances, depending on the appliance model)

If the pan supports are fitted with rubber rests, ensure that these are also cleaned. The rests may come loose and the pan support may scratch the hob.

After cleaning and drying the steel grids, ensure that they are correctly fitted.

Maintenance

Always clean off any liquid as soon as it is spilled. This will prevent food remains from sticking to the hob surface and you will save yourself any unnecessary effort.

After each use, clean the surface of the respective burner parts once they have cooled down. If any residue is left (baked-on food, drops of grease etc.), however little, it will become stuck to the surface and more difficult to remove later. The holes and grooves must be clean for the flame to ignite properly.

The movement of some pans may leave metal residue on the pan supports.

Clean the burners and pan supports using soapy water and scrub with a non-wire brush.

Do not clean individual parts of the appliance in the dishwasher.

Always dry the burners and pan supports completely. Water droplets or damp patches on the hob at the start of cooking may damage the enamel.

Caution!

The stainless steel cleaner must not be used in the area around the controls. The (printed) symbols may be wiped off.

Thoroughly remove spilt cooking oil and acidic foodstuffs such as lemon immediately.

Under no circumstance should abrasive cleaning powder be used to clean the control panel. The inscriptions can be scratched off as a result.

The burner caps are coated with black enamel. Due to the high temperatures, discolouration may occur. Their burner function is not adversely affected by this.

Never slide pans across the glass surface, as you may scratch it. In addition, try not to drop heavy or sharp objects on the glass. Never strike any part of the hob.

Grains of sand that may come from cleaning fruits and vegetables will scratch the glass surface.

Melted sugar, or foods which contain a lot of sugar which may have spilled, should be cleaned off the hob immediately, using the glass scraper.

Avoid spilling salt on the surface of the electric hob.

Trouble shooting

Sometimes certain faults detected can be easily resolved. Before calling the Technical Assistance Service, bear in mind the following advice:

Fault	Possible cause	Solution
The general electrical system is malfunctioning.	Defective fuse.	Check the fuse in the main fuse box and change it if it is damaged.
	The automatic safety switch or circuit breaker has tripped.	Check the main control panel to see if the automatic safety switch or circuit breaker has tripped.
The automatic switching on function does not work.	There may be food or cleaning products stuck between the ignition sparkers and the burners.	The space between the ignition sparker and the burner must be clean.
	The burners are wet.	Dry the burner caps carefully.
	The burner caps are not correctly positioned.	Check that the burner caps are correctly positioned.
The burner flame is not uniform.	The appliance is not earthed, is poorly connected or the earthing is faulty.	Contact the installation technician.
	The burner components are not correctly positioned.	Correctly place the parts on the appropriate burner.
The gas flow is not normal or there is no gas.	The grooves on the burner are dirty.	Clean the grooves on the burner.
	The gas supply is blocked by gas taps.	Open all gas taps.
The kitchen smells of gas.	If the gas is supplied from a gas cylinder, check that it is not empty.	Change the gas cylinder.
	A gas tap has been left on.	Turn off the taps.
	Incorrect coupling of gas cylinder.	Check that the coupling is sound.
The burner immediately switches off after releasing the control knob.	Possible gas leak.	Shut off the gas supply, ventilate the premises and immediately notify an authorised installation technician to check and certify the installation. Do not use the appliance until ensuring that there is no gas leak in the installation or appliance itself.
	The control knob was not held down for long enough.	Once the burner is on, hold the control knob down a few seconds longer.
	The grooves on the burner are dirty.	Clean the grooves on the burner.

After-sales service

Our after-sales service is there for you if your appliance needs to be repaired. We will always find the right solution in order to avoid unnecessary visits from a service technician.

E number and FD number

To help speed up the process, please have your product number (E no.) and production number (FD no.) ready when you contact after-sales service. The nameplate containing these numbers is found on the underside of your cooker. To save time in the event of a fault, you can make a note of the numbers for your appliance and the after-sales service telephone number in the space below.

E no.	FD no.
--------------	---------------

After-sales service

Note that, even within the guarantee period, you are responsible for service and repair costs in the case of improper use or misuse.

Please find the contact data of all countries in the enclosed customer service list.

To book an engineer visit and product advice

GB 0344 892 8979

Calls charged at local or mobile rate.

IE 01450 2655

0.03 € per minute at peak. Off peak 0.0088 € per minute.

Rely on the professionalism of the manufacturer. You can therefore be sure that the repair is carried out by trained service technicians who carry original spare parts for your appliances.

Warranty conditions

In the unlikely event that the appliance is damaged or does not meet your expectations in terms of quality, please inform us as soon as possible. For the warranty to be valid, the appliance must not have been tampered with, or used inappropriately.

The applicable warranty conditions are those set out by the company's representative office in the country of purchase. Detailed information is available from retail outlets. Proof of purchase must be presented to obtain the benefits of the warranty.

We reserve the right to introduce changes.

Packaging and equipment used

If your appliance has a crossed-out dustbin symbol , please note the following.

Environmentally-friendly disposal

Dispose of packaging in an environmentally-friendly manner.



This appliance is labelled in accordance with European Directive 2012/19/EU concerning used electrical and electronic appliances (waste electrical and electronic equipment - WEEE). The guideline determines the framework for the return and recycling of used appliances as applicable throughout the EU.

The packaging of your appliance has been manufactured using only the materials which are strictly necessary to guarantee efficient protection during transport. These materials are 100% recyclable, thus reducing the environmental impact. You can also contribute to caring for the environment by following the advice below:

- Dispose of the packaging in the appropriate recycling bin.
- Before you get rid of an old appliance, make sure you disable it. Contact your local authority to find out the address of your nearest recycling centre to dispose of your appliance.
- Do not pour used oil down the sink. Collect it in a sealed container and take it to an appropriate collection point or, failing that, place it in the rubbish bin (it will end up in a controlled dump; this is probably not the best option, but it will avoid contaminating ground water).

Energy-saving tips

- Always place suitable lids on saucepans. When cooking without a lid, considerably more energy is required. A glass lid means that you can see inside without having to lift the lid.
- Use pots and pans with even bases. Uneven bases increase energy consumption.
- The diameter of pot and pan bases should be the same size as the hotplate. In particular, small saucepans on the hotplate

cause energy losses. Please note: cookware manufacturers often indicate the upper diameter of the saucepan. This is usually bigger than the diameter of the base of the pan.

- Use a small saucepan for small quantities. A larger, less full saucepan requires a lot of energy.
- Cook with only a little water. This will save energy. Vitamins and minerals in vegetables are preserved.
- Always cover as large an area of the hotplate as possible with your saucepan.
- Switch to a lower heat setting in good time.
- Select a suitable ongoing cooking setting. You will waste energy by using an ongoing cooking setting which is too high.
- Use the residual heat of the hob. For longer cooking times, you can switch the hotplate off 5-10 minutes before the end of the cooking time.

Measures to be noted during transport

Secure all mobile parts on the appliance using an adhesive tape that can be removed without leaving any traces. Secure the top cover, if available, to the appliance sides using adhesive tape.

Keep the original appliance packaging. Only transport the appliance in the original packaging. Observe the transport arrows on the packaging.

If the original packaging is no longer available

pack the appliance in protective packaging to guarantee sufficient protection against any transport damage.

The appliance must be transported upright, with the hotplate and the burners facing upwards. Do not place any heavy objects on the appliance.



Robert Bosch Hausgeräte GmbH

Carl-Wery-Straße 34

81739 München

Germany

www.bosch-home.com



9001119022