



HB24D.52.

Steam oven

SIEMENS

Important safety information..... 3
 Causes of damage5
Your new appliance..... 5
 Control panel5
 Operating modes6
 Automatic calibration6
Your accessories..... 6
 Accessories6
 Inserting accessories6
 Cooking compartment7
 Optional accessories7
Before using for the first time 7
 Setting the clock7
 Setting the water hardness range7
 First use7
 Cleaning the accessories before use8
Operating the appliance 8
 Filling the water tank8
 Switching on the appliance.....8
 Switching off the appliance.....8
 After each use9
Time-setting options 9
 Setting the timer9
 Setting the cooking time.....9
 Setting a later end time9
 Setting the clock 10
Automatic programmes 10
 Setting a programme 10
 Notes about the programmes 11
 Programme tables 11
Childproof lock 12
 Activating the childproof lock 12
 Deactivating the childproof lock 12
Basic settings 12
Care and cleaning 13
 cleaning agents..... 13
 Descaling..... 14

Removing and fitting the appliance door..... 15
 Cleaning the door panels..... 15
 Cleaning the rails..... 15
Troubleshooting 16
 Replacing the cooking compartment bulb 17
 Changing the door seal..... 17
After-sales service 18
 E number and FD number..... 18
Environmental protection..... 18
 Environmentally-friendly disposal..... 18
 Tips for saving energy 18
Tables and tips 18
 Accessories 18
 Cookware..... 18
 Cooking time and quantity..... 18
 Distributing food evenly..... 18
 Pressure-sensitive food 18
 Cooking a menu 18
 Vegetables 19
 Side dishes and pulses 19
 Poultry and meat..... 20
 Fish 20
 Soup vegetables, Miscellaneous 21
 Dessert, compote 21
 Reheating food..... 21
 Defrosting..... 21
 Proving dough..... 22
 Juicing..... 22
 Preserving 22
 Frozen products..... 23

Additional information on products, accessories, replacement parts and services can be found at www.siemens-home.com and in the online shop www.siemens-eshop.com

Important safety information

Read these instructions carefully. Only then will you be able to operate your appliance safely and correctly. Retain the instruction manual and installation instructions for future use or for subsequent owners.

This appliance is only intended to be fully fitted in a kitchen. Observe the special installation instructions.

Check the appliance for damage after unpacking it. Do not connect the appliance if it has been damaged in transport.

Only a licensed professional may connect appliances without plugs. Damage caused

by incorrect connection is not covered under warranty.

This appliance is intended for domestic use only. The appliance must only be used for the preparation of food and drink. The appliance must be supervised during operation. Only use this appliance indoors.

This appliance may be used by children over the age of 8 years old and by persons with reduced physical, sensory or mental capabilities or by persons with a lack of experience or knowledge if they are supervised or are instructed by a person

responsible for their safety how to use the appliance safely and have understood the associated hazards.

Children must not play with the appliance. Children must not clean the appliance or carry out general maintenance unless they are at least 8 years old and are being supervised.

Keep children below the age of 8 years old at a safe distance from the appliance and power cable.

Always slide accessories into the cooking compartment correctly. See "*Description of accessories*" in the instruction manual.

Risk of fire!

Combustible items stored in the cooking compartment may catch fire. Never store combustible items in the cooking compartment. Never open the appliance door if there is smoke inside. Switch off the appliance and unplug it from the mains or switch off the circuit breaker in the fuse box.

Risk of burns!

- The appliance becomes very hot. Never touch the interior surfaces of the cooking compartment or the heating elements. Always allow the appliance to cool down. Keep children at a safe distance.
- Accessories and ovenware become very hot. Always use oven gloves to remove accessories or ovenware from the cooking compartment.
- Hot steam may escape during operation. Do not touch the ventilation openings. Keep children away.

Risk of scalding!

- The accessible parts become hot during operation. Never touch the hot parts. Keep children at a safe distance.
- Water in a hot cooking compartment may create hot steam. Never pour water into the hot cooking compartment.
- When you open the appliance door, hot steam can escape. Steam may not be visible, depending on its temperature. When opening, do not stand too close to the appliance. Open the appliance door carefully. Keep children away.
- The water in the evaporator dish is still hot even after the appliance has been switched off. Do not empty the evaporator dish immediately after switching off the

appliance. Allow the appliance to cool down before cleaning it.

- Hot liquid may spill over the sides of cooking containers when they are removed from the cooking compartment. Remove hot cooking containers with care and always wear oven gloves.

Risk of injury!

- Scratched glass in the appliance door may develop into a crack. Do not use a glass scraper, sharp or abrasive cleaning aids or detergents.
- Flammable liquids can catch fire in the cooking compartment when it is hot (explosion). Do not fill the water tank with any flammable fluids (e.g. alcoholic drinks). Only fill the water tank with water or with the descaling solution that is recommended by us.

Risk of electric shock!

- Incorrect repairs are dangerous. Repairs may only be carried out by one of our trained after-sales engineers. If the appliance is faulty, unplug the mains plug or switch off the fuse in the fuse box. Contact the after-sales service.
- The cable insulation on electrical appliances may melt when touching hot parts of the appliance. Never bring electrical appliance cables into contact with hot parts of the appliance.
- Penetrating moisture may cause an electric shock. Do not use any high-pressure cleaners or steam cleaners.
- When replacing the cooking compartment bulb, the bulb socket contacts are live. Before replacing the bulb, unplug the appliance from the mains or switch off the circuit breaker in the fuse box.
- A defective appliance may cause electric shock. Never switch on a defective appliance. Unplug the appliance from the mains or switch off the circuit breaker in the fuse box. Contact the after-sales service.

Causes of damage

Caution!

- Do not place anything on the cooking compartment floor. Do not cover it with aluminium foil. A build-up of heat could damage the appliance.
The cooking compartment floor and the evaporator dish must always be kept clear. Always place ovenware in a perforated cooking container or on a wire rack.
- Aluminium foil in the cooking compartment must not come into contact with the door panel. This could cause permanent discolouration of the door panel.
- Ovenware must be heat and steam resistant.
- Do not use ovenware that shows signs of rust. Even the smallest spots of rust can lead to corrosion in the cooking compartment.
- When steaming with a perforated cooking container, always insert the baking tray or the solid cooking container underneath. Dripping liquid is caught.

- Do not store moist food in the closed cooking compartment for long periods. It can lead to corrosion in the cooking compartment.
- If the door seal is very dirty, the appliance door will no longer close properly during operation. The fronts of adjacent units could be damaged. Always keep the door seal clean and replace when necessary.
- Do not place anything on the open appliance door. The appliance could be damaged.
- Do not carry or hold the appliance by the door handle. The door handle cannot support the weight of the appliance, and could break.
- The cooking compartment in your appliance is made of high grade stainless steel. Improper care can lead to corrosion in the cooking compartment. Refer to the care and cleaning instructions in the instruction manual. Remove food residues from the cooking compartment as soon as the appliance has cooled.

Your new appliance

In this section, you will find information on

- the control panel
- the types of heating
- automatic calibration

Control panel

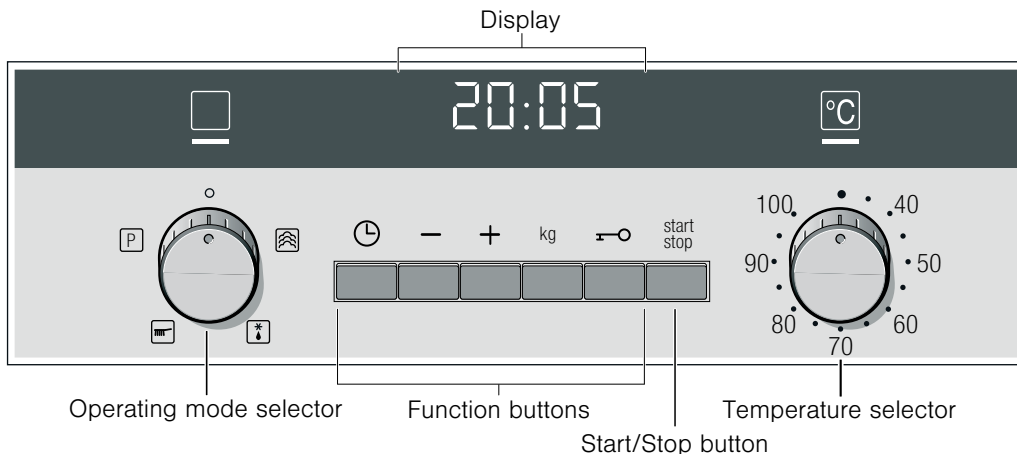





Control element		Use
Operating mode selector		Selects the operating mode
Function buttons		Press briefly: Selects time-setting option (see section: Time-setting options) Press and hold when the appliance is off: Selects the basic settings (see section: Basic settings)
		Changes the values for the clock, cooking time, weight etc.
		Selects the weight of the food for a programme (see section: Automatic programmes)
		Switches childproof lock on and off (see section: Childproof lock)
Start/Stop button		Press briefly: starts cooking operation or interrupts (pause) Press and hold: ends cooking operation
		Sets the temperature (see section: Switching on the appliance)

Pop-out control knob

The operating mode and temperature selectors are pop-out knobs. Simply push the appropriate control knob to pop it in or out.

Operating modes

You can use the operating mode selector to set your appliance for various different applications.

Operating mode	Application
 Steam 35 - 100 °C	For vegetables, fish, side dishes, for juicing fruit and for blanching. For proving dough (at 35 °C). The food is completely surrounded by steam.
 Defrosting 35 - 60 °C	For vegetables, meat, fish and fruit. The moisture gently transfers the heat to the food. The food does not dry out or lose shape.
 Descaling	For descaling the water system and the evaporator dish (see section: Descaling)
 "Automatic programmes"	Selects a programme (see section: Automatic programmes)

Automatic calibration

The boiling temperature of water depends on the air pressure. During calibration, the appliance is adapted to the pressure conditions in the location where it is installed. This happens automatically when you first use the appliance (see section: First use). More steam develops than usual.

It is important that the appliance steams without interruption for 20 minutes at 100 °C. Do not open the appliance door during this time.

If the appliance was not able to calibrate itself automatically (for example, because the appliance door was opened), the

calibration process is carried out again during the next cooking operation.

After moving house

So that the appliance automatically adjusts itself to its new location, you must reset the appliance to the factory settings (see section: Basic settings) and repeat the initial start-up process (see section: First use).

After a power cut

The appliance saves the calibration settings even in the event of a power cut or disconnection from the mains. Recalibration is not necessary.

Your accessories

The accessories supplied with your appliance are suitable for making many dishes. Ensure that you always insert the accessories into the cooking compartment the right way round.

Accessories

Use only the accessories supplied with the product or available from the after-sales service. They are specially designed for your appliance.

Your appliance is equipped with the following accessories:



Cooking container, solid, GN 2/3, 40 mm deep

For catching dripping liquid when steaming and for cooking rice, pulses and cereals

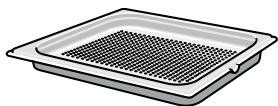

Cooking container, perforated, GN 2/3, 40 mm deep

for the steaming of whole fish or large quantities of vegetables, for juicing berries, etc.

You can buy accessories from the after-sales service, from specialist retailers or online.

Inserting accessories

The accessories are equipped with a locking function. The locking function prevents the accessories from tilting when they are pulled out. The accessories must be inserted into the cooking compartment correctly for the tilt protection to work properly.

Note: Your appliance will include different accessories, depending on the appliance equipment.

When inserting the cooking container, ensure that the lug (a) is facing downwards.

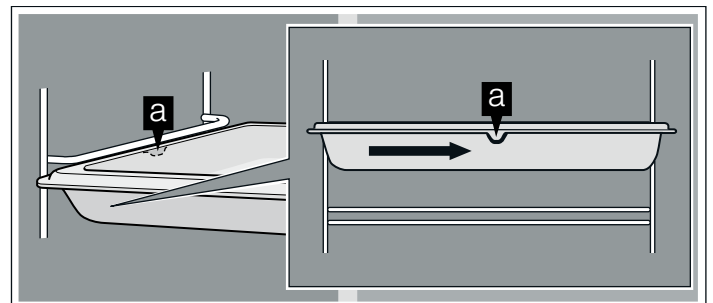

When inserting the wire rack, check

- that the lug (a) is pointing downwards
- that the safety lug on the wire rack is at the back and facing upwards.

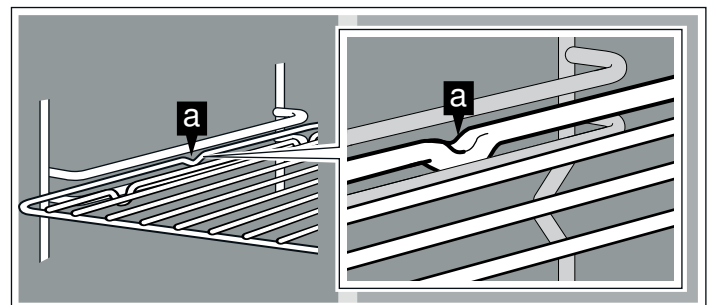

Cooking compartment

The cooking compartment has four shelf positions. The shelf positions are counted from the bottom up.

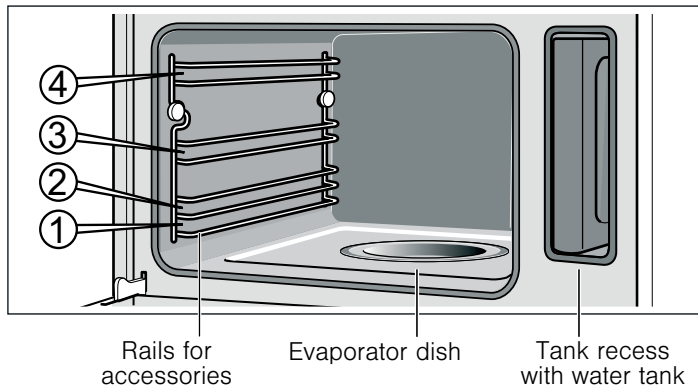

Caution!

- Do not place anything on the cooking compartment floor. Do not cover it with aluminium foil. A build-up of heat could damage the appliance.
The cooking compartment floor and the evaporator dish must always be kept clear. Always place ovenware in a perforated cooking container or on a wire rack.
- Do not slide any accessories between the shelf positions, or they may tip.

Optional accessories

You can obtain further accessories from specialist retailers:

Accessories	Order no.
Cooking container, solid, GN $\frac{2}{3}$, 40 mm deep	HZ36D543
Cooking container, perforated, GN $\frac{2}{3}$, 40 mm deep	HZ36D543G
Cooking container, solid, GN $\frac{2}{3}$, 28 mm deep (baking tray)	HZ36D542
Cooking container, solid, GN $\frac{1}{3}$, 40 mm deep	HZ36D513
Cooking container, perforated, GN $\frac{1}{3}$, 40 mm deep	HZ36D513G
Porcelain cooking container, solid, GN $\frac{2}{3}$	HZ36D533P
Porcelain cooking container, solid, GN $\frac{1}{3}$	HZ36D513P
Wire rack	HZ36DR4
Cleaning sponge	643 254
Descaler	311 138
Honeycomb microfibre cloth	460 770

Before using for the first time

In this section you will find out which steps are required before using the appliance for the first time:

- Setting the clock
- Setting the water hardness range
- Starting the appliance for the first time
- Cleaning the accessories before use

Setting the clock

After the power has been connected, the \odot symbol and **0:00** light up in the display. Set the clock.

1. Press the \odot button.
The time **12:00** is shown in the display.
2. Use the **+** or **-** button to set the clock.
After a few seconds, the time which has been set is applied.

Setting the water hardness range

Descal your appliance regularly. This is the only way to prevent damage.

Your appliance automatically displays when it needs descaling. It has been preset to water hardness range "medium". Change the value if your water is softer or harder.

You can check the water hardness with the test strips supplied or ask your water supplier.

If your water is very hard, we recommend that you use softened water.

You can only dispense with descaling completely if you exclusively use softened water. If this is the case, change the water hardness to "softened".

You can change the water hardness range in the basic settings when the appliance is switched off.

1. If required, turn the operating mode selector to \odot to switch off the appliance.
2. Press and hold the \odot button until **c 0 2** appears in the display.
3. Press the \odot button repeatedly until **c 5 2** appears ("moderate" water hardness range).
4. Press the **+** or **-** button to change the water hardness range. Possible values:

c 5 0	softened	-
c 5 1	soft	I
c 5 2	moderate	II
c 5 3	hard	III
c 5 4	very hard	IV

5. Press and hold the \odot button to exit basic settings.
The change is saved.

First use

Before first use, heat the empty appliance for 20 minutes to 100 °C using Steam. Do not open the appliance door during this time. The appliance is automatically calibrated (see section: Automatic calibration).

1. Fill and insert the water tank (see section: Filling the water tank).
Before using for the first time, moisten the seal in the tank cover with a little water.
2. Turn the operating mode selector to Steam.
3. Turn the temperature selector to 100 °C.

4. Press the **start/stop** button.

The appliance heats up to 100 °C. The cooking time (20 minutes) does not start to count down until the set temperature has been reached. Do not open the appliance door during this time.

The cooking operation ends automatically and a signal sounds.

5. To switch off the appliance, turn the operating mode and temperature selectors to 0.

Leave the appliance door ajar until the appliance has cooled down.

Cleaning the accessories before use

Using soapy water and a soft cloth, clean the accessories thoroughly before first use.

Operating the appliance

In this section, you can read about

- how to fill the water tank
- how to switch the appliance on and off
- what to note after each cooking operation

Filling the water tank

When you open the appliance door, you will see the water tank on the right-hand side.

Caution!

Use of unsuitable liquids may damage the appliance

- Only use fresh tap water, softened water or uncarbonated mineral water.
- If your tap water is very hard, we recommend that you use softened water.
- Do not use distilled water, highly chlorinated tap water (> 40 mg/l) or other liquids.

You can obtain information about your tap water from your water supplier. The water hardness can be checked with the test strips enclosed.

Fill the water tank before each use:

1. Open the appliance door and take out the water tank (fig. A).
2. Fill the water tank with cold water up to the "max" mark (fig. B).

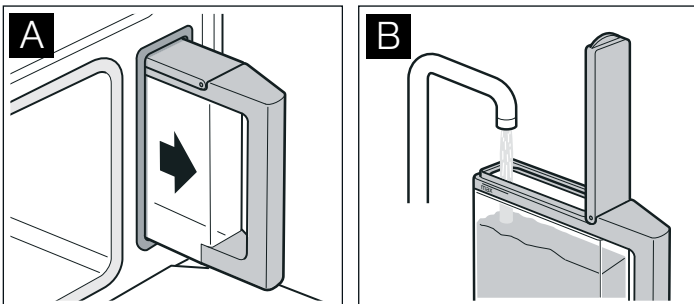

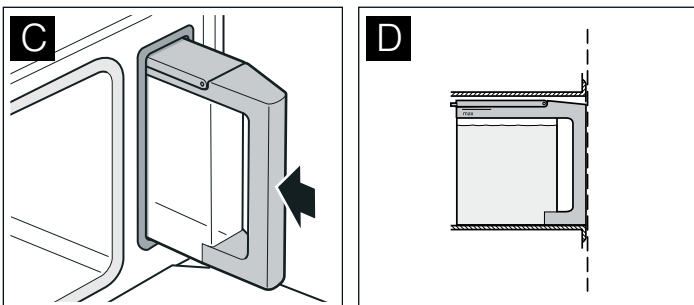

3. Close the tank cover until you feel it engage.
4. Slide in the water tank all the way (fig. C).



The tank must be flush with the water tank recess (fig. D).

Switching on the appliance

1. Turn the operating mode selector to the required operating mode.
2. Turn the temperature selector to set the temperature.

Operating mode	Temperature range	Default cooking time
 Steam	35 - 100 °C	20 minutes
 Defrosting	35 - 60 °C	30 minutes

A default cooking time appears in the display.

3. Use the **+** or **-** button to set the cooking time.

4. Press the **start/stop** button.

The appliance heats up.

The  symbol lights up until the set temperature has been reached and each time reheating starts.

In the  Steam operating mode, the cooking time does not start counting down until the heating-up time has finished.

Changing the temperature

You can change the temperature at any time. To do this, turn the temperature selector.

Pause

Briefly press the **start/stop** button to interrupt cooking (pause). The cooling fan may continue running. Press the **start/stop** button to start. If you open the appliance door during cooking, operation is interrupted. Close the appliance door and press the **start/stop** button to restart.

If you have switched on the basic setting "Continue after closing door", restarting is not required (see section: Basic settings).

Display

If the water tank is empty, an audible signal sounds and the  symbol (Fill water tank) appears. Cooking is interrupted.

1. Open the appliance door carefully.
Hot steam will escape.
2. Remove the water tank, fill up to the "max" mark and slide the tank back in.
3. Press the **start/stop** button.

Switching off the appliance

Risk of scalding!

Hot steam may escape when the appliance door is opened. Open the appliance door carefully during or after cooking. When opening the door, do not lean over it. Ensure that, depending on the temperature, steam is not visible.

Press and hold the **start/stop** button to end cooking.

When the cooking time has elapsed, the cooking operation is ended automatically. A signal sounds. Press the  button to stop the signal.

To switch off the appliance, turn the operating mode and temperature selectors back to the 0 position.

The cooling fan may continue to run when you open the appliance door.

After each use

Emptying the water tank.

1. Open the appliance door carefully.
Hot steam will escape.
2. Remove and clean the water tank.
3. Thoroughly dry the seal in the tank cover and the tank recess in the appliance.

Caution!

Do not dry the water tank in the hot cooking compartment. This will damage the water tank.



Time-setting options

Your appliance has many different time-setting options. You can use the  button to access the menu and switch between the individual options.

All the time symbols are lit during the time when you can make settings. The  arrow shows you the time-setting option that is active.





A time-setting option that has already been set can be changed directly using the **+** or **-** button when the  arrow is next to the time symbol.

Checking the time-setting option

Press the  button repeatedly until the  arrow is in front of the particular symbol. The display shows the value for a few seconds.

Setting the timer



You can use the timer as a kitchen timer. It runs independently of the cooking operation. The timer has its own signal. In this way, you can tell whether it is the timer or a cooking time which has elapsed.

1. Press the  button.
The time symbols light up in the display; the  arrow is in front of the .
2. Use the **+** or **-** button to set the timer.
Default value for the **+** button = 10 minutes
Default value for the **-** button = 5 minutes
After a few seconds, the timer duration set is applied. The timer starts. The  symbol for the timer appears, and the time can be seen counting down.

Changing the timer duration

Use the **+** or **-** button to change the timer duration. After a few seconds, the change is applied.

Once the timer duration has elapsed

A signal sounds.  appears in the display. Switch the timer off with the .

Cancelling the timer duration

Use the **-** button to reset the timer duration to . After a few seconds, the change is applied.

Setting the cooking time

The cooking time sets the length of time your dish will be cooked for. When the cooking time has elapsed, the cooking operation is ended automatically.

Example in the picture:
Cooking time of 45 minutes.

Prerequisites:



An operating mode and temperature have been set.

Drying the cooking compartment

Risk of scalding!

The water in the evaporator dish may still be hot. Allow it to cool before wiping.

1. Leave the appliance door ajar until the appliance has cooled down.
2. Once it has cooled down, wipe out the cooking compartment and the evaporator dish with the enclosed cleaning sponge and dry well with a soft cloth.
3. Remove food residues in the cooking compartment as soon as the appliance has cooled down.
4. Wipe units and handles dry where condensation has formed.

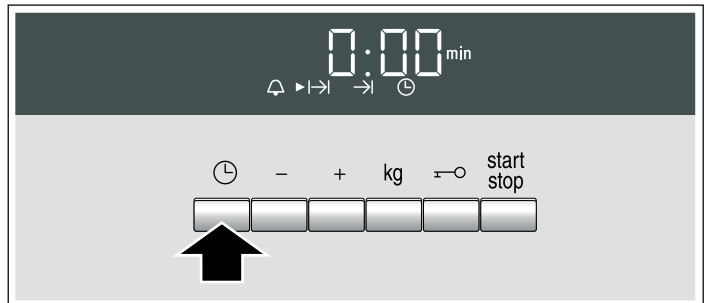

1. Press the  button repeatedly until the  arrow is in front of the  cooking time.



The time symbols light up.  appears in the display.

2. Use the **+** or **-** button to set the cooking time.
Default value for the **+** button = 30 minutes
Default value for the **-** button = 10 minutes





3. Press the  button.
The appliance heats up. The cooking time starts counting down in the display. The  symbol lights up.
In the  Steam operating mode, the cooking time does not start counting down until the heating-up time has finished.

Changing the cooking time

Use the **+** or **-** button to change the cooking time. If the timer has been set, first press the  button. After a few seconds, the change is applied.

The cooking time has elapsed

A signal sounds. The appliance stops heating. Press the  button to stop the signal. To switch off the appliance, turn the operating mode and temperature selectors back to . Open the appliance door carefully. Hot steam will escape.

Setting a later end time

You can delay the time at which you wish your dish to be ready. The appliance starts automatically and is ready at the desired time. You can, for example, put your dish in the compartment in

the morning and set the cooking time so that it is ready at lunchtime.

Ensure that food is not left in the cooking compartment for too long as it may spoil.



For some programmes it is not possible to change the end time.

In the  Steam operating mode, the cooking time does not start counting down until the heating-up time has finished. The selected end time is delayed by the length of the heating-up time.



Example in the picture:
it is 10:30, the dish will take 45 minutes to cook but should be ready at 12:30.

Prerequisites:

An operating mode and temperature have been set.

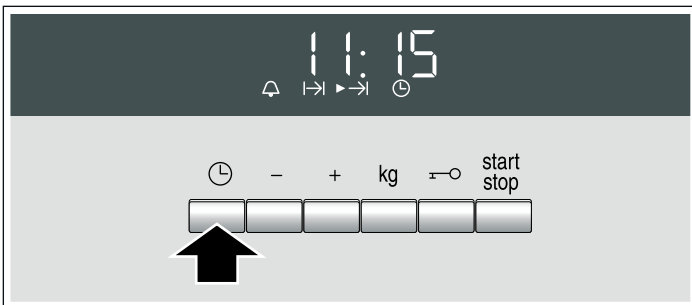
1. Press the  button repeatedly until the arrow is in front of the cooking time, like this: .
2. Use the **+** or **-** button to set the cooking time.
3. Press the  button.



The  arrow is in front of  (End time). The time at which the dish will be ready is displayed.



4. Use the **+** button to delay the end time.



5. Press the  button.

The appliance switches to standby. The  end time is shown in the display. Cooking starts at the right time. The cooking time starts counting down in the display.

Changing the end time



Use the **+** or **-** button to change the end time. If the timer has been set, first press the  button repeatedly until the arrow is in front of the End time, like this: .

After a few seconds, the change is applied. Do not change the end time if the cooking time has already started to elapse. The cooking result would no longer be correct.

The cooking time has elapsed

A signal sounds. The appliance stops heating. Press the  button to stop the signal. To switch off the appliance, turn the operating mode and temperature selectors back to 0. Open the appliance door carefully. Hot steam will escape.

Cancelling the end time

Use the **-** button to set the end time back to the current time. If the timer has been set, first press the  button repeatedly until the arrow is in front of the End time, like this: .



After a few seconds, the change is applied. The selected cooking time starts counting down straight away.

Setting the clock



Example:

change the clock from summer time to winter time.

No other time-setting option should be set.

1. Press the  button repeatedly until the  arrow is in front of the clock.
2. Use the **+** or **-** button to set the clock.
After a few seconds, the time which has been set is applied.

After a power cut

After a power cut, the  and  symbols light up in the display. Press the  button. Use the **+** or **-** button to set the clock. After a few seconds, the time which has been set is applied.

Hiding the clock

You can hide the clock. It is then only visible when the appliance is in operation (see section: Basic settings).

Automatic programmes



You can prepare food really easily with 20 different programmes.

In this section, you will find out

- how to set one of the automatic programmes
- hints and tips on the programmes
- which programmes you can set

Setting a programme

Select the appropriate programme from the programme table. Follow the instructions for the programmes.

1. Turn the operating mode selector to .
The first programme  appears in the display panel.



2. Use the **+** or **-** button to set the programme.

3. Press the kg button.

A default weight appears in the display.

For some programmes, you do not have to enter a weight. If this is the case, 0.00 kg appears.

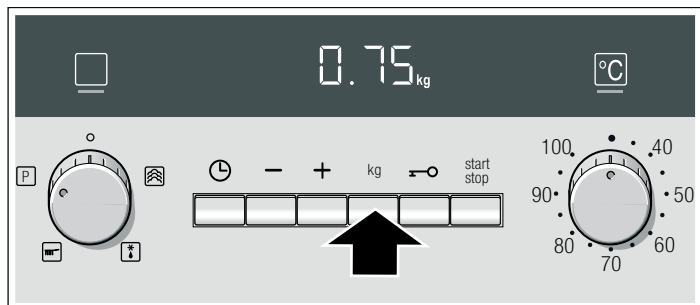

4. Use the + or - button to set the weight of the food.

5. Press the start stop button.

The programme cooking time counts down in the display.

Set a later end time

You can delay the end time for some programmes. The programme will be started later and finish at the desired time (see section: Time-setting options).

Cancelling the programme

Press and hold the start stop button and turn the operating mode selector back to 0.

End of the programme

A signal sounds. Cooking has finished. To switch off the appliance, turn the operating mode selector back to 0.

⚠ Risk of scalding!

Hot steam may escape when the appliance door is opened. Open the appliance door carefully during or after cooking. When opening the door, do not lean over it. Ensure that, depending on the temperature, steam is not visible.

Notes about the programmes

All programmes are designed for cooking on one level.

The cooking result may vary according to the size and quality of the food.

Ovenware

Use the suggested ovenware. All meals have been tested using this ovenware. The cooking result may change if you use different ovenware.

When cooking in the perforated cooking container, also insert the solid cooking container at level 1. Dripping liquid is caught.

Amount/weight

Do not fill the food more than 4 cm deep in the accessories.

The automatic programmes require the weight of the food. The total weight must be within the specified weight range.

Cooking time

After the programme is started the cooking time is displayed. It

may change during the first 10 minutes, as the heating-up time depends, among other things, on the temperature of the food and the water.

Prepare vegetables P1 - P6

Do not season vegetables until after cooking.

Prepare cereal products/lentils P07 - P10

Weigh the food and add the correct ratio of water:

Basmati rice 1:1.5

Couscous 1:1

Brown rice 1:1.5

Lentils 1:2

Enter the weight excluding liquid.

Stir cereal products after cooking. The remaining water is quickly absorbed.

Steam chicken breast P11

Do not place chicken breasts on top of each other in the ovenware.

Steam fish P12 - P13

When preparing fish, grease the perforated cooking container.

Do not place fish fillets on top of one another. Enter the weight of the heaviest fillet and select pieces as similar in size as possible.

Prepare fruit compote P14

The programme is only suitable for fruits with stones and pips. Weigh the fruit and add approximately 1/3 of the water, and add sugar and spices according to taste.

Prepare rice pudding P15

Weigh the rice and add 2.5 times the amount of milk. Ensure the level of rice and milk in the accessory is no higher than 2.5 cm. Enter the weight of the rice pudding excluding liquid. Stir after cooking. The remaining milk is quickly absorbed.

Prepare yoghurt P16

Heat the milk to 90 °C on the hob. Then leave to cool to 40 °C. If you are using UHT milk, you do not need to heat it.

Stir in one to two teaspoons of natural yoghurt per 100 ml milk, or the corresponding amount of yoghurt culture into the milk. Pour the mixture into clean jars and seal them.

After preparation, leave the glass jars to cool in the refrigerator.

Sterilise bottles P18

Always clean baby bottles with a bottle brush immediately after feeding. Then clean them in the dishwasher.

Place the bottles in the perforated cooking container so that they do not touch one another.

Dry the bottles with a clean cloth after sterilising. The process corresponds to normal sterilisation by boiling.

Cook eggs P19 - P20

Pierce the eggs before cooking. Do not place eggs on top of each other. Size M corresponds to a unit weight of approx. 50 g.

Programme tables

Follow the instructions for the programmes.

Programme	Notes	Accessories	Level	
P 1*	Steam cauliflower florets	florets of equal size	perforated + solid cooking container	3 1
P 2*	Steam broccoli florets	florets of equal size	perforated + solid cooking container	3 1
P 3*	Steam green beans	-	perforated + solid cooking container	3 1
P 4*	Steam sliced carrots	slices, approx. 3 mm thick	perforated + solid cooking container	3 1

* You can delay the end time for this programme

Programme	Notes	Accessories	Level	
P 5	Steam frozen mixed vegetables	-	perforated + solid cooking container	3 1
P 6*	Unpeeled boiled potatoes	medium-sized, 4 - 5 cm thick	perforated + solid cooking container	3 1
P 7	Basmati rice	max. 0.75 kg	solid cooking container	2
P 8	Brown rice	max. 0.75 kg	solid cooking container	2
P 9	Couscous	max. 0.75 kg	solid cooking container	2
P 10	Lentils	max. 0.55 kg	solid cooking container	2
P 11	Steam fresh chicken breast	total weight 0.2 - 1.5 kg	perforated + solid cooking container	3 1
P 12	Steam whole, fresh fish	0.3 - 2 kg	perforated + solid cooking container	3 1
P 13	Steam fresh fish fillet	max. 2.5 cm thick	perforated + solid cooking container	3 1
P 14*	Fruit compote	-	solid cooking container	2
P 15	Rice pudding	-	solid cooking container	2
P 16	Yoghurt in glass jars	-	jars + solid cooking container	2
P 17*	Reheat side dishes	-	solid cooking container	2
P 18*	Disinfect bottles	-	perforated cooking container	2
P 19*	Hard-boiled eggs	eggs, size M, max. 1.8 kg	perforated + solid cooking container	3 1
P 20*	Soft-boiled eggs	eggs, size M, max. 1 kg	perforated + solid cooking container	3 1

* You can delay the end time for this programme

Childproof lock

The appliance has a childproof lock to prevent children switching it on accidentally or changing a setting.



Activating the childproof lock

Press and hold the  button for approx. 4 seconds until the  symbol appears.

The control panel is locked.

Even with the childproof lock activated, you can switch the appliance off, cancel the signal using the  button, stop operation using the Stop button and set the timer.

Deactivating the childproof lock



Press and hold the  button until the  symbol disappears. You can make settings again.

Basic settings

Your appliance has various Basic settings, which are preset at the factory. You can, however, change these basic settings as required.

If you want to cancel all the changes, you can restore the factory settings.

1. If required, turn the operating mode selector to 0 to switch off the appliance.

2. Press and hold the  button until  2 appears in the display.









3. Press the  button until the desired basic setting appears.

4. Press the  or  button to change the basic setting.

5. Press and hold the  button to exit basic settings.

The change is saved.

You can change the following basic settings:

Basic setting	Function	Possible settings
 2	Display brightness	 1 = dark  2 = medium  3 = bright
 2	Signal duration: Sets the length of the audible signal at the end of an operation	 1 = short (10 seconds)  2 = medium (2 minutes)  3 = long (5 minutes)

Basic setting	Function	Possible settings
c2 1	Displays the clock when the appliance is off	c2 0 = off c2 1 = on
c3 1	Continues after the door is closed. Not necessary to restart after the door has been opened	c3 0 = off c3 1 = on
c4 2	Time until changes are automatically saved	c4 1 = short (2 seconds) c4 2 = medium (5 seconds) c4 3 = long (10 seconds)
c5 2	Sets the water hardness range for the descaling indicator	c5 0 = softened c5 1 = soft (I) c5 2 = medium (II) c5 3 = hard (III) c5 4 = very hard (IV)
c6 0	Steam cooking heat signal	c6 0 = off c6 1 = on
c7 0	Restore the appliance to the factory settings: <ul style="list-style-type: none"> ■ all changes to the basic settings are cleared ■ Automatic calibration is carried out again 	c7 0 = do not restore c7 1 = restore

Care and cleaning

In this section, you will find information on

- the care and cleaning of your appliance
- Descaling

Risk of short circuit!

Do not use high-pressure cleaners or steam jet cleaners to clean your appliance.

Caution!

Risk of surface damage: Do not use

- harsh or abrasive cleaning agents
- oven cleaners

- corrosive or aggressive cleaners, or those containing chlorine
- cleaning agents with a high alcohol content

If such an agent comes into contact with the front of the appliance, wash it off immediately with water.

Caution!

Risk of surface damage: If descaler comes into contact with the front of the appliance or any other sensitive surfaces, wash it off immediately with water.

Remove food residues from the cooking compartment as soon as the appliance has cooled.

Salts are very corrosive and can cause rust. Remove remains of acidic sauces (ketchup, mustard) or salted food from the cooking compartment immediately after cooling.

Do not use hard scouring pads or cleaning sponges.

cleaning agents

Appliance exterior (with aluminium front)	Use soapy water and dry with a soft cloth. Mild window cleaning agent - wipe over the aluminium front horizontally and without applying pressure using a soft window cloth or a lint-free microfibre cloth.
Appliance exterior (with stainless steel front)	Use soapy water and dry with a soft cloth. Always remove flecks of limescale, grease, starch and albumin (e.g. egg white) immediately. Special stainless steel cleaning agents can be obtained from the after-sales service or from specialist retailers.
Cooking compartment interior with evaporator dish	Hot, soapy water or a vinegar solution - use the enclosed cleaning sponge or a soft washing-up brush. Caution! The cooking compartment could rust.: Do not use steel pads or scourers.
Water tank	Soapy water - do not clean in the dishwasher.
Tank recess	Rub dry after every use
Seal in the water tank lid	Thoroughly dry after every use
Rails	See section: Cleaning the rails
Door panels	See section: Cleaning the door panels

Caution!

Risk of surface damage: After cleaning, wipe the door panels with glass cleaner, then dry. Otherwise, stains will be caused that will not be able to be removed.

Door seal	Hot soapy water
Accessories	Soak in hot soapy water. Clean with a brush or washing-up sponge or in the dishwasher. If the rails are discoloured by starchy foods (e.g. rice), clean them with a vinegar solution.

Cleaning sponge

The enclosed cleaning sponge is very absorbent. Use the cleaning sponge only for cleaning the cooking compartment and for removing residual water from the evaporator dish.

Wash the cleaning sponge thoroughly before using for the first time. You can wash the cleaning sponge in the washing machine (hot wash).

Microfibre cloth

The honeycomb microfibre cloth is particularly suitable for cleaning sensitive surfaces such as glass, glass ceramic, stainless steel or aluminium (product no. 460 770, also available from our online eShop). It removes liquid and greasy deposits in one go.

Descaling

The appliance must be descaled at regular intervals in order for it to continue operating correctly. The **calc** indicator reminds you to do this.

You can only dispense with descaling completely if you exclusively use softened water.

The descaling consists of:

- Descal (approx. 30 minutes), then refill the water tank and empty the evaporator dish
- 1st rinse (20 seconds), then empty the evaporator dish
- 2nd rinse (20 seconds), then remove the remaining water

All three steps must be completed in full. The appliance is ready for operation again only after the 2nd rinse.

Descaler

Only use the liquid descaler recommended by the after-sales service for descaling (product no. 311 138, also available online from the eShop). Other descalers may damage the appliance.



1. Prepare a descaling solution by mixing 300 ml water and 60 ml liquid descaler.
2. Empty the water tank and fill with descaling solution.

Caution!

Risk of surface damage: If descaler comes into contact with the front of the appliance or any other sensitive surfaces, wash it off immediately with water.



Starting descaling

The cooking compartment must have cooled down completely.

1. Turn the operating mode selector to  Descal.
2. Slide in the water tank containing the descaling solution and close the appliance door.
3. Press the  button.

The descaling process starts. The light in the cooking compartment remains switched off.

Emptying the evaporator dish and refilling the water tank

A signal sounds after approx. 30 minutes. The  symbol (Fill water tank) and  0:40 min are displayed.

1. Open the appliance door.
2. Rinse the water tank thoroughly, fill with water and reinsert.



The  symbol (empty evaporator dish) appears.

3. Remove the descaling solution from the evaporator dish using the cleaning sponge supplied.
4. Close the appliance door.

1st rinse

Press the  button.
The appliance starts rinsing.

Emptying the evaporator dish



After 20 seconds,  (Empty evaporator dish) and  0:20 appear.

1. Open the appliance door.
2. Thoroughly rinse out the cleaning sponge.
3. Remove the remaining water from the evaporator dish using the cleaning sponge.
4. Close the appliance door.

2nd rinse

Press the  button.
The appliance starts rinsing.



Removing the remaining water



After 20 seconds,  (Empty evaporator dish) and  0:00 appear.

1. Open the appliance door.
 2. Remove the remaining water from the evaporator dish using the cleaning sponge.
 3. Wipe out the cooking compartment using the cleaning sponge and then dry with a soft cloth.
 4. To switch off the appliance, turn the operating mode selector back to .
- Descaling is complete.

Cancelling the descaling

Note: After cancelling, the appliance must be rinsed twice. The appliance is locked against other applications until the second rinsing operation is complete.

1. Press and hold the  button to cancel the descaling process.
 0:40 min appears in the display.
To ensure that no descaling solution remains in the appliance, it must be rinsed twice after a cancellation.

2. Press the  button.
The  symbol (Fill water tank) appears.

Now proceed as described in the "Emptying the evaporator dish and refilling the water tank" section.

Descaling the evaporator dish only

You can also use the  Descal operating mode if you do not wish to descale the whole appliance, but only the evaporator dish in the cooking compartment.

The only difference is as follows:

1. Prepare a descaling solution by mixing 100 ml water and 20 ml liquid descaler.
2. Completely fill the evaporator dish with descaling solution.
3. Fill the water tank with water only.
4. Start the  Descal operating mode as described.

You can also descale the evaporator dish manually.

Removing and fitting the appliance door

You can remove the appliance door to clean it more thoroughly.

⚠ Risk of injury!

The hinges of the appliance door may snap shut with great force. Always open the hinge locking lever fully when removing the appliance door and close it fully after refitting. Do not reach into the hinge.

⚠ Risk of injury!

If the appliance door has only been unhinged on one side, do not reach into the hinge. The hinge can snap back with great force. Call the after-sales service.

Removing the appliance door

1. Open the appliance door fully.
2. Fold out the locking levers on the left and right fully (figure A). The hinges are secured and cannot snap closed.
3. Close the appliance door until you feel some resistance.
4. With both hands, grip the door on the left and right-hand side, close the door a little more and pull it out (Fig. B).

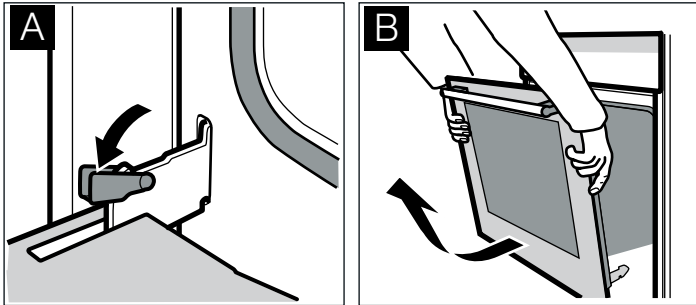

Fitting the appliance door

Refit the appliance door after cleaning.

1. Insert the hinges in the left and right-hand bracket (figure C). The notch on both hinges must engage.
2. Open the appliance door fully.
3. Close the locking levers on the left and right-hand side fully (figure D).

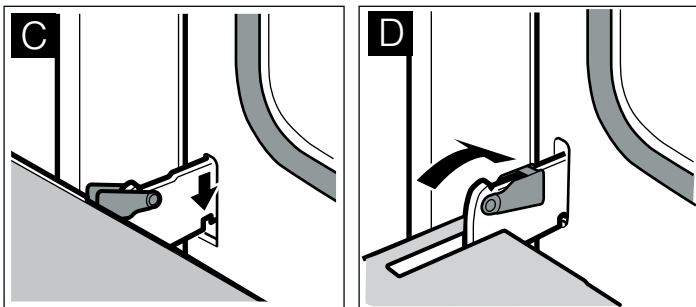

The appliance door is secured and can no longer be removed.

4. Close the appliance door.

Cleaning the door panels

To assist with cleaning, the inner door panel can be removed from the appliance door.

⚠ Risk of injury!

The components inside the appliance door may have sharp edges. Take care not to cut yourself. Wear protective gloves.

⚠ Risk of injury!

The appliance must not be used again until the door panels and appliance door have been correctly fitted.

Removing the door panel

Note: Before removing, make a note of the orientation in which the door panel is fitted, so that it is not refitted the wrong way round.

1. Unhook the appliance door and lay it on a soft, clean surface with the front side facing downwards (see section: Removing and installing the appliance door).
2. Unscrew the cover at the top left and right of the appliance door and detach it (figure A).
3. Lift the door panel and remove it (figure B).

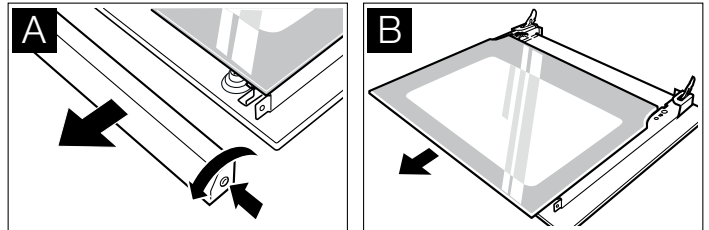

Cleaning

Clean the door panel with glass cleaner and a soft cloth.

Caution!

Do not use any sharp or abrasive medium or a glass scraper. The glass could be damaged.

Fitting the door panel

1. Slide in the door panel all the way.
2. Put the cover back in place and screw it in.
3. Refit the appliance door.

Cleaning the rails

The rails can be removed for cleaning.

⚠ Risk of burning due to hot components in the cooking compartment!

Wait until the cooking compartment has cooled down.

Detaching the rails

Note: Swing the front of the rail as far as possible (until you feel resistance), because otherwise the appliance side panel may become bent.

1. Carefully press the front of the rail upwards until it becomes detached, and release it from the holder at the side (fig. A).
2. Detach the rail from the holder and remove it (fig. B).

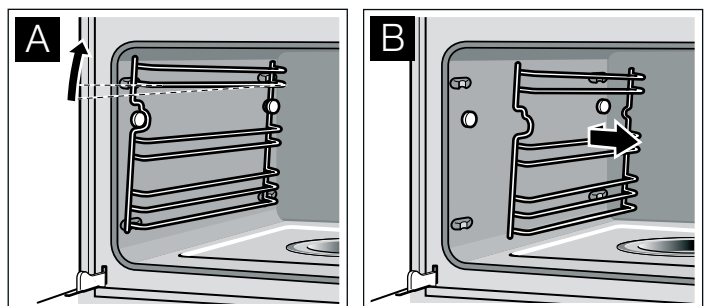

3. Clean the rails with washing-up liquid and a sponge/brush or
Clean the rails in the dishwasher.

Attaching the rail

1. Position the rail so that the indentations are facing upwards.
2. Hook the rail in at the back and push it towards the rear until it engages (fig. C).
3. Hook the front of the rail onto the holder and press down until it engages and is fixed level in place in the appliance once more (fig. D).

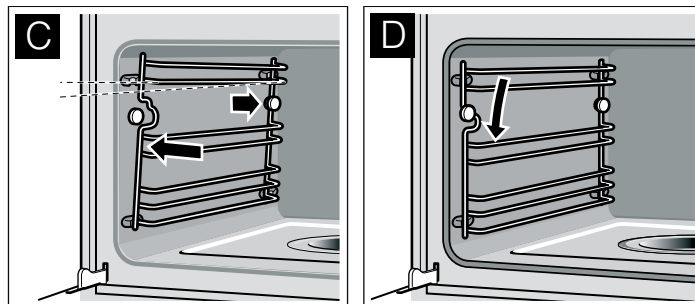

Each set of rails only fits on one side.

Troubleshooting





Malfunctions often have simple explanations. Please read the following instructions before calling the after-sales service.

Repairs may only be carried out by fully trained after-sales service technicians. Incorrect repairs to your appliance may present considerable risks for the user.

⚠ Risk of electric shock!

- Work on the appliance electronics may only be performed by a specialist.
- Always disconnect the appliance from the power supply when work is carried out on the electronics. Switch off the circuit breaker or remove the fuse from your household fuse box.

Problem	Possible cause	Notes/remedy
The appliance does not work	The plug is not plugged into the mains.	Connect the appliance to the electricity supply
	Power cut	Check whether other kitchen appliances are working
	Fuse defective	Check in the fuse box to make sure that the fuse for the appliance is OK
	Faulty operation	Switch the appliance off using the fuse in the fuse box. Wait approximately 10 seconds and then switch it back on
Appliance does not start. ▶ → 0:40 min appears in the display.	Descaling has been cancelled	Turn the operating mode selector to and rinse the appliance twice (see section: Cancelling descaling)
The appliance cannot be started	The appliance door is not fully closed	Close the appliance door.
The appliance is not in operation. A duration is shown in the display	A control knob was unintentionally pressed	Press and hold the button
	The button was not pressed after making the setting	Press the button briefly to start the cooking operation, or press and hold the button to cancel the setting
and 0:00 light up in the display	Power cut	Reset the clock time (see section: "Time-setting options")
The indicator appears even though the water tank is full	The water tank has not been pushed in properly	Slide in the water tank until it engages
	The detection system is not working	Call the after-sales service
The indicator appears even though the water tank is not yet empty, or the water tank is empty but the indicator does not appear	The water tank is dirty. The mobile water level indicators are jammed	Shake and clean the water tank. If the parts cannot be released, obtain a new water tank from the after-sales service.
The water tank empties for no discernible reason. The evaporator dish is overflowing	The water tank was not closed properly	Close the lid until you feel it engage.
	The tank cover seal is dirty	Clean the seal
	The seal in the tank cover is defective	Obtain a new water tank from the after-sales service
The evaporator dish has boiled dry even though the water tank is full	The water tank has not been pushed in properly	Slide in the water tank until it engages
	The feed line is blocked	Descale the appliance. Check whether the water hardness is set correctly
The indicator appears	The appliance has not been used for at least 2 days and the water tank is full	Empty and clean the water tank. Always empty the water tank after cooking

Problem	Possible cause	Notes/remedy
There is a "pop" noise during cooking	Cold/warm effect with frozen food, caused by the steam	This is normal.
When you cook with steam, a lot of steam is created	The appliance is being automatically calibrated	This is normal.
When cooking with steam, a lot of steam is created again	The appliance is unable to calibrate itself automatically if cooking times are too short	Reset the appliance to the factory settings (see Basic settings section). Then start steaming at 100 °C for 20 minutes
Steam escapes from the ventilation slots during cooking		This is normal.
The appliance is not producing steam properly	Limescale has formed in the appliance	Start descaling (see Section: Descaling)
Error message E0 11 appears in the display	A button was pressed for too long or is jammed	Press the  button to clear the fault message. Press each button and check that it is clean
An E... error message appears in the display	Technical fault.	Press the  button to delete the error message. Reset the clock if required. If the error message appears again, call the after-sales service
The appliance is not heating. The colon flashes in the display	A button combination was actuated	Set the Steam operating mode to 35 °C, then press and hold the  button until a signal sounds. Press the  button again briefly

Replacing the cooking compartment bulb

Heat-resistant 25 W, 220/240 V bulbs, E14 bulb sockets and the seals are available from the after-sales service. Please specify the E number and FD number of your appliance.

Risk of burns!

Allow the cooking compartment and cooking compartment light to cool before changing the bulb.

1. Switch off the fuse in the fuse box or unplug at the mains.
2. Turn the cover anti-clockwise to remove.
3. Screw out the bulb by turning it anti-clockwise and replace with a bulb of the same type.
4. Slide the new seals and the clamping ring onto the glass cover in the right order.

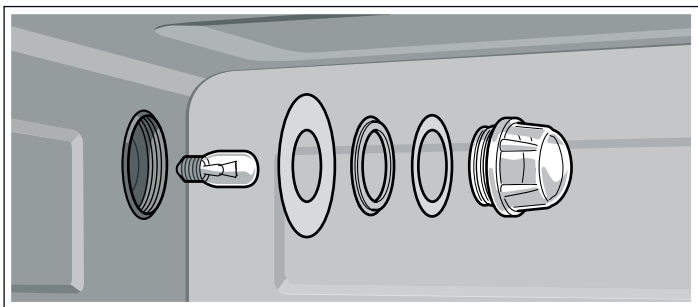

5. Screw the glass cover with the seals back on again.
 6. Connect the appliance to the mains and reset the clock.
- Never operate the appliance without the glass cover and seals.

Replacing the glass cover or seals

Any damaged glass cover or seals must be replaced. Please provide the after-sales service with the E number and FD number of your appliance.

Changing the door seal

If the seal around the outside of the cooking compartment is faulty, it must be replaced. Replacement seals for your appliance can be obtained from the after-sales service. Please specify the E number and FD number of your appliance.

1. Open the appliance door.
2. Pull off the old seal.
3. Push in the new door seal at one point and pull it in all the way round. The joint must be at the side.
4. Check again that the seal is correctly fitted in the corners.

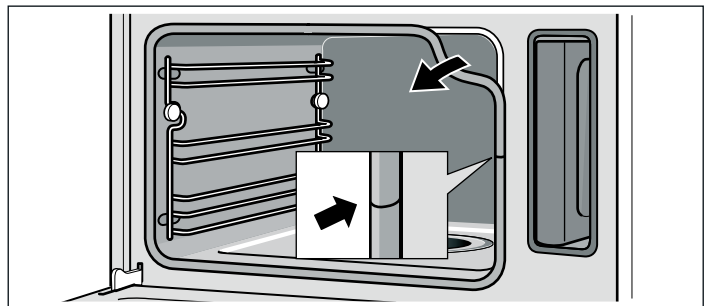

After-sales service

Our after-sales service is there for you if your appliance needs to be repaired. We will always find the right solution in order to avoid unnecessary visits from a service technician.

E number and FD number

When calling us, please give the product number (E no.) and the production number (FD no.) so that we can provide you with the correct advice. The rating plate bearing these numbers can be found on the lower left-hand side when you open the appliance door.

You can make a note of the numbers of your appliance and the telephone number of the after-sales service in the space below to save time should it be required.

E no.	FD no.
-------	--------

After-sales service

Please note that there will be a fee for a visit by a service technician in the event of a malfunction, even during the warranty period.

Please find the contact data of all countries in the enclosed customer service list.

To book an engineer visit and product advice

GB 0844 8928999

Calls from a BT landline will be charged at up to 3 pence per minute. A call set-up fee of up to 6 pence may apply.

IE 01450 2655

Trust the expertise of the manufacturer, and rest assured that the repair will be carried out by trained service technicians using original spare parts for your domestic appliance.

Environmental protection

Environmentally-friendly disposal

Dispose of packaging in an environmentally-friendly manner.



This appliance is labelled in accordance with European Directive 2012/19/EG concerning used electrical and electronic appliances (waste electrical and electronic equipment - WEEE). The guideline determines the framework for the return and recycling of used appliances as applicable throughout the EU

Tips for saving energy

- Only preheat the appliance if this is specified in the recipe or in the operating instructions table.
- Open the appliance door as infrequently as possible while the food is cooking.
- When steaming, you can cook on several levels at the same time. When preparing foods with different cooking times, those with the longest cooking time should be placed in the oven first.

Tables and tips

Steaming is a particularly gentle way of cooking food. The steam surrounds the dish thereby preventing a loss of nutrients from the food. Cooking takes place without excess pressure. As a result, the shape, colour and typical aroma of the dishes are retained.

The tables contain a selection of dishes which are particularly suitable for your steam oven. You can find out which operating mode, accessories, temperature and cooking time are best to select. Unless otherwise stated, the information given applies to inserting accessories when the appliance is cold.

Accessories

Use the accessories provided.

When steaming in the perforated cooking container, always insert the solid cooking container underneath. Dripping liquid is caught.

Cookware

When using ovenware, always place it in the middle of the perforated cooking container.

Ovenware must be heat and steam resistant. Cooking times are increased if thick-walled ovenware is used.

Food which would normally be prepared in a bain marie should always be covered with foil (e.g. when melting chocolate).

Cooking time and quantity

The cooking times when steaming depend on the item size, but do not depend on the total quantity. The appliance can steam food to a maximum of 2 kg.

Follow the unit sizes given in the tables. The cooking time is reduced for smaller pieces and increased for larger ones. Cooking time is also influenced by the quality and ripeness of the food. The values quoted can therefore only serve as a guideline.

Distributing food evenly

Always distribute the food evenly in the ovenware. It will not cook evenly if the layers are of different depths.

Pressure-sensitive food

When layering delicate foods in the cooking container, do not pile them too high. It is better to use two containers.

Cooking a menu

With steam, you can cook a whole menu at once, without the different flavours mixing. Place the food with the longest cooking time in the appliance first and delay the rest until the appropriate time. This means that all the food will be ready at the same time.

The overall cooking time is extended with menu cooking, as a little steam escapes each time the appliance door is opened and has to be reheated.

Vegetables

Place the vegetables in the perforated cooking container and insert at level 3. Always insert the solid cooking container underneath at level 1. Dripping liquid is caught.

Food	Size	Accessories	Operating mode	Temperature in °C	Cooking time in min.
Artichokes	whole	perforated + solid	Steam	100	30 - 35
Cauliflower	whole	perforated + solid	Steam	100	30 - 40
Cauliflower	Florets	perforated + solid	Steam	100	10 - 15
Broccoli	Florets	perforated + solid	Steam	100	8 - 10
Peas	-	perforated + solid	Steam	100	5 - 10
Fennel	Slices	perforated + solid	Steam	100	10 - 14
Vegetable flan	-	1.5 l bain-marie dish + perforated cooking container at level 2	Steam	100	50 - 70
Green beans	-	perforated + solid	Steam	100	20 - 25
Carrots	Slices	perforated + solid	Steam	100	10 - 20
Kohlrabi	Slices	perforated + solid	Steam	100	15 - 20
Leeks	Slices	perforated + solid	Steam	100	4 - 6
Sweetcorn	whole	perforated + solid	Steam	100	25 - 35
Swiss chard*	Shredded	perforated + solid	Steam	100	8 - 10
Green asparagus*	whole	perforated + solid	Steam	100	7 - 12
White asparagus*	whole	perforated + solid	Steam	100	10 - 15
Spinach*	-	perforated + solid	Steam	100	2 - 3
Romanesco	Florets	perforated + solid	Steam	100	8 - 10
Brussels sprouts	Florets	perforated + solid	Steam	100	20 - 30
Beetroot	Whole	perforated + solid	Steam	100	40 - 50
Red cabbage	Shredded	perforated + solid	Steam	100	30 - 35
White cabbage	Shredded	perforated + solid	Steam	100	25 - 35
Courgettes	Slices	perforated + solid	Steam	100	2 - 3
Mangetout	-	perforated + solid	Steam	100	8 - 12

* Preheat the appliance

Side dishes and pulses

Add water or liquid in the proportion specified. For example: 1:1.5 = add 150 ml liquid for every 100 g rice.

You may select any shelf position you wish for the solid cooking container.

Food	Ratio	Accessories	Level	Operating mode	Temperature in °C	Cooking time in min.
Unpeeled boiled potatoes (medium size)	-	perforated + solid	3 1	Steam	100	35 - 45
Boiled potatoes (quartered)	-	perforated + solid	3 1	Steam	100	20 - 25
Brown rice	1:1.5	solid	-	Steam	100	30 - 40
Long grain rice	1:1.5	solid	-	Steam	100	20 - 30
Basmati rice	1:1.5	solid	-	Steam	100	20 - 30
Parboiled rice	1:1.5	solid	-	Steam	100	15 - 20
Risotto	1:2	solid	-	Steam	100	30 - 35
Lentils	1:2	solid	-	Steam	100	30 - 45
Canellini beans, pre-softened	1:2	solid	-	Steam	100	65 - 75
Couscous	1:1	solid	-	Steam	100	6 - 10
Unripe spelt grain, coarse ground	1:2.5	solid	-	Steam	100	15 - 20
Millet, whole	1:2.5	solid	-	Steam	100	25 - 35

Food	Ratio	Accessories	Level	Operating mode	Temperature in °C	Cooking time in min.
Wheat, whole	1:1	solid	-	Steam	100	60 - 70
Dumplings	-	perforated + solid	3 1	Steam	95	20 - 25

Poultry and meat

Poultry

Food	Amount	Accessories	Level	Operating mode	Temperature in °C	Cooking time in min.
Chicken breast	per 0.15 kg	solid	2	Steam	100	15 - 25
Duck breast*	per 0.35 kg	solid	2	Steam	100	12 - 18

* Sear first and wrap in foil

Beef

Food	Amount	Accessories	Level	Operating mode	Temperature in °C	Cooking time in min.
Thin slice of sirloin, medium*	1 kg	solid	2	Steam	100	25 - 35
Thick piece of sirloin, medium*	1 kg	perforated + solid	3 1	Steam	100	30 - 40

* Sear first and wrap in foil

Pork

Food	Amount	Accessories	Level	Operating mode	Temperature in °C	Cooking time in min.
Pork fillet*	0.5 kg	solid	2	Steam	100	10 - 12
Pork medallions*	approx. 3 cm thick	solid	2	Steam	100	10 - 12
Smoked pork ribs	Sliced	solid	2	Steam	100	15 - 20

* Sear first and wrap in foil

Sausages

Food	Accessories	Level	Operating mode	Temperature in °C	Cooking time in min.
Wiener sausages	perforated + solid	3 1	Steam	80 - 90	12 - 18
Bavarian veal sausages	perforated + solid	3 1	Steam	80 - 90	15 - 20

Fish

Food	Amount	Accessories	Level	Operating mode	Temperature in °C	Cooking time in min.
Sea bream, whole	per 0.3 kg	perforated + solid	3 1	Steam	80 - 90	15 - 25
Sea bream fillet	per 0.15 kg	perforated + solid	3 1	Steam	80 - 90	10 - 20
Fish terrine	Bain-marie 1.5 l	solid	2	Steam	70 - 80	40 - 80
Trout, whole	per 0.2 kg	perforated + solid	3 1	Steam	80 - 90	12 - 15
Cod fillet	per 0.15 kg	perforated + solid	3 1	Steam	80 - 90	10 - 14
Salmon fillet	per 0.15 kg	perforated + solid	3 1	Steam	100	8 - 10
Mussels	1.5 kg	solid	2	Steam	100	10 - 15

Food	Amount	Accessories	Level	Operating mode	Temperature in °C	Cooking time in min.
Ocean perch fillet	per 0.15 kg	perforated + solid	3 1	Steam	80 - 90	10 - 20
Sole rolls, stuffed		perforated + solid	3 1	Steam	80 - 90	10 - 20

Soup vegetables, Miscellaneous

Food	Accessories	Level	Operating mode	Temperature in °C	Cooking time in min.
Royale	solid	2	Steam	90	15 - 20
Semolina dumplings	perforated + solid	3 1	Steam	90 - 95	7 - 10
Hard-boiled eggs (Size M, max. 1.8 kg)	perforated + solid	3 1	Steam	100	10 - 12
Soft-boiled eggs (Size M, max. 1 kg)	perforated + solid	3 1	Steam	100	6 - 8

Dessert, compote

Compote:

Weigh the fruit and add approximately $\frac{1}{3}$ of the water, and add sugar and spices according to taste.

Rice pudding

Weigh the rice and add 2.5 times the amount of milk. Ensure the level of rice and milk in the accessory is no higher than 2.5 cm. Stir after cooking. The remaining milk is quickly absorbed.

Yoghurt

Heat the milk to 90 °C on the hob. Then leave to cool to 40 °C. If you are using UHT milk, you do not need to heat it.

Stir in one to two teaspoons of natural yoghurt per 100 ml milk, or the corresponding amount of yoghurt culture into the milk. Pour the mixture into clean jars and seal them.

After preparation, leave the glass jars to cool in the refrigerator.

Food	Accessories	Operating mode	Temperature in °C	Cooking time in min.
Yeast dumplings	solid	Steam	100	20 - 25
Crème caramel	Small moulds + perforated	Steam	90 - 95	15 - 20
Rice pudding*	solid	Steam	100	25 - 35
Yoghurt*	Portion sized jars + perforated	Steam	40	300 - 360
Apple compote	solid	Steam	100	10 - 15
Pear compote	solid	Steam	100	10 - 15
Cherry compote	solid	Steam	100	10 - 15
Rhubarb compote	solid	Steam	100	10 - 15
Plum compote	solid	Steam	100	15 - 20

* You can also use the appropriate programme (see section: Automatic programmes)

Reheating food

Using Reheat, dishes can be gently reheated. They taste and look like they have been freshly prepared.

Food	Accessories	Level	Operating mode	Temperature in °C	Cooking time in min.
Vegetables	solid cooking container	3	Steam	100	12 - 15
Pasta, potatoes, rice	solid cooking container	3	Steam	100	5 - 10

Defrosting

When freezing, lay the food as flat as possible and in portion-sized pieces at -18 °C. Do not freeze excessively large quantities. Once defrosted, food will not keep for as long and spoils more quickly than fresh food.

Leave the food to defrost in the freezer bag, on a plate or on the perforated cooking container. Always insert the solid cooking container underneath. The food is then not left lying in the defrost water and the cooking compartment remains clean.

Use the Defrost operating mode.

If necessary, the food can occasionally be split apart or pieces which have already defrosted can be removed from the appliance.

After defrosting, allow the food to stand for a further 5 - 15 minutes to come up to room temperature.

Health risk!

When defrosting food from animal sources, you must remove the liquid that escapes during defrosting. It must never come into contact with other food. Bacteria could be transferred.

After defrosting, operate the steam oven for 15 minutes at 100 °C using the Steam type of heating.

Defrost meat

Allow pieces of meat which are to be breadcrumbed to defrost to the point where seasoning and breadcrumbs adhere to the meat.

Defrosting poultry

Remove from packaging before defrosting. You must tip the defrost liquid away.

Food	Amount	Accessories	Level	Temperature in °C	Cooking time in min.
Chicken drumsticks	0.25 kg	perforated + solid	3 1	45 - 50	55 - 60
Berries	0.5 kg	perforated + solid	3 1	50 - 55	15 - 20
Fish fillet	0.4 kg	perforated + solid	3 1	40 - 45	50 - 55

Proving dough

With the Steam operating mode dough proves significantly more quickly than at room temperature.

You may select any shelf position you wish for the perforated cooking container.

Place the dough bowl in the perforated cooking container. Do not cover the dough.

Dish	Amount	Accessories	Temperature in °C	Cooking time in min.
Yeast dough	1 kg	Bowl + perforated container	35	20 - 30
Sourdough	1 kg	Bowl + perforated container	35	20 - 30

Juicing

Before juicing, place the berries in a bowl and sprinkle with sugar. Leave to stand for at least one hour to draw out the juice.

Add the berries to the perforated cooking container and insert at level 3. Insert the solid cooking container at level 1 to catch the juice.

Finally, place the berries in a cloth and squeeze out the rest of the juice.

Food	Accessories	Level	Operating mode	Temperature in °C	Cooking time in min.
Raspberries	perforated + solid	3 1	Steam	100	30 - 45
Redcurrants	perforated + solid	3 1	Steam	100	40 - 50

Preserving

Preserve food which is as fresh as possible. When foods are stored for a relatively long period, their vitamin content is reduced and they ferment and spoil more easily.

Only use fruit and vegetables which are in perfect condition.

The following foods cannot be preserved with your appliance: Contents of tins, meat, fish or pastry dough.

Check preserving jars, rubber rings, clips and springs.

Clean rubber rings and jars thoroughly with hot water. The "Sterilise bottles" programme is also suitable for cleaning glasses.

Place the jars in the perforated cooking container. They must not be in contact with each other.

After the specified cooking time, open the appliance door.

Do not remove the preserving jars from the appliance until they have completely cooled down.

Food	Accessories	Level	Operating mode	Temperature in °C	Cooking time in min.
Vegetables	1-litre preserving jars	2	Steam	100	30 - 120
Stone fruits	1-litre preserving jars	2	Steam	100	25 - 30
Pip fruits	1-litre preserving jars	2	Steam	100	25 - 30

Frozen products

Observe the instructions on the packaging.

The cooking times indicated apply to dishes placed in a cold cooking compartment.

Food	Accessories	Level	Operating mode	Temperature in °C	Cooking time in min.
Pasta, fresh, refrigerated*	solid	2	Steam	100	5 - 10
Trout	perforated + solid	3 1	Steam	80 - 100	20 - 25
Salmon fillet	perforated + solid	3 1	Steam	80 - 100	20 - 25
Broccoli	perforated + solid	3 1	Steam	100	4 - 6
Cauliflower	perforated + solid	3 1	Steam	100	5 - 8
Beans	perforated + solid	3 1	Steam	100	4 - 6
Peas	perforated + solid	3 1	Steam	100	4 - 6
Carrots	perforated + solid	3 1	Steam	100	3 - 5
Mixed vegetables	perforated + solid	3 1	Steam	100	4 - 8
Brussels sprouts	perforated + solid	3 1	Steam	100	5 - 10

* Add a little liquid

Siemens-Electrogeräte GmbH
Carl-Wery-Straße 34
81739 München
Germany



9000765420 45 920906