

SIEMENS

Making cooking as much fun as eating

Please read this instruction manual. This will ensure that you make use of all the technical benefits the cooker has to offer. You will be given important safety information. You will then be introduced to the individual components of your new cooker and we will show you how to adjust it step by step. It is quite simple.

The tables list the settings and shelf heights for numerous well-known dishes. All these dishes are tested in our cooking studio.

In the unlikely event of a fault, look here for information on how to rectify minor faults yourself.

A detailed table of contents will help you to find your way around quickly.

Enjoy your meal!

Instruction manual



HB 37L.60
HB 37R.60

en

9000 067 196

Table of contents

Important information	6
Before installation	6
Safety information	6
Reasons for damage	7
Your new cooker	8
The control panel	8
Control panels and displays	9
Arrows for selecting the type of heating	10
Symbols for adjusting the values set	11
Types of heating	11
Oven and shelving accessories	14
Cooling fan	17
Before using for the first time	18
Heating up the oven	18
Pre-cleaning the accessories	18
Switching the oven on and off	19
Main switch	19
Setting the oven	19
Setting procedure	20
You want the oven to switch off automatically	21
You want the oven to switch on and off automatically	22
Residual heat indicator	23

Table of contents

Rapid heating	24
Automatic program	25
Ovenware	25
Preparing food	25
Programs	26
How long will the meal take to cook?	28
Setting procedure	28
You want the oven to switch on and off automatically	29
Tips on the automatic program	30
Time	32
Setting procedure	32
Timer	33
Setting procedure	33
Basic settings	34
Changing the basic settings	35
Child-proof lock	36
Automatic time limiter	36

Table of contents

Care and cleaning	37
Oven exterior	37
Oven	37
Self-cleaning oven roof and side walls	39
Cleaning the rails	40
Cleaning the glass panels	41
Seal	43
Accessories	43
Steam filter	44
Troubleshooting	45
Replacing the oven light	47
Replacing the oven light	47
After-sales service	49
Packaging and old appliances	49

Table of contents

Tables and tips	50
Cakes and pastries	50
Baking tips	54
Meat, poultry, fish	55
Tips for roasting and grilling	58
Bakes, gratins, toast	58
Frozen foods	59
Slow cooking	60
Tips on slow cooking	61
Special meals	62
Defrosting	62
Drying	63
Preserving	63
Energy saving tips	65
Acrylamide in food	66
What can you do?	67
Test dishes	68

Important information

Read this instruction manual carefully. Only then will you be able to operate your cooker safely and correctly.

Please keep the instruction and installation manual in a safe place. Please pass on the instruction manual to the new owner if you sell the appliance.

Before installation

Transport damage

Check the appliance after unpacking it. Do not connect the appliance if it has been damaged in transport.

Electrical connection

The cooker may only be connected by an approved specialist. Losses resulting from damage caused by incorrect connection will invalidate warranty claims.

Safety information

Hot oven



This appliance is intended for domestic use only. Only use the cooker for food preparation.

Open the oven door carefully. Hot steam may escape. Never touch the internal surfaces of the oven or the heating elements. There is a risk of burning. Children must be kept at a safe distance from the appliance.

Never store combustible items in the oven. Risk of fire

Never clamp leads of electrical appliances in the hot oven door. The insulation on the leads could melt. There is a risk of short-circuiting.

Repairs



Incorrectly done repairs are dangerous. There is a risk of electrocution.

Repairs may only be carried out by after-sales service technicians who have been fully trained by BSH.

If there is a fault, switch off the oven fuse at the fuse box.

Call the after-sales service.

Reasons for damage

Baking sheet or aluminium foil on the oven floor

Do not place baking sheets on the oven floor. Do not line the oven floor with aluminium foil.

This causes heat to accumulate. Baking and roasting times will no longer be correct and the enamel will be damaged.

Water in the oven

Never pour water directly into a hot oven. This could damage the enamel.

Fruit juice

When baking very moist fruit cakes, do not put too much on the baking sheet. Fruit juice dripping from the baking sheet leaves stains that cannot be removed.

It is recommended that you use the deeper universal pan.

Cooling with the oven door open

Only leave the oven to cool with the door closed. Do not allow anything to become trapped in the oven door. Even if you only leave the oven door open slightly, the fronts of adjacent units may become damaged over time.

Very dirty oven seal

If the oven seal is very dirty, the oven door will no longer close properly when the oven is in use. The fronts of adjacent units could be damaged. Keep the oven seal clean.

Using the oven door as a seat

Do not stand or sit on the oven door.

Your new cooker

Here you will learn more about your new oven. The control panel and its switches and indicators are explained here. The heating modes and the accessories included with your oven will be explained here.

The control panel

Details vary according to the appliance model.

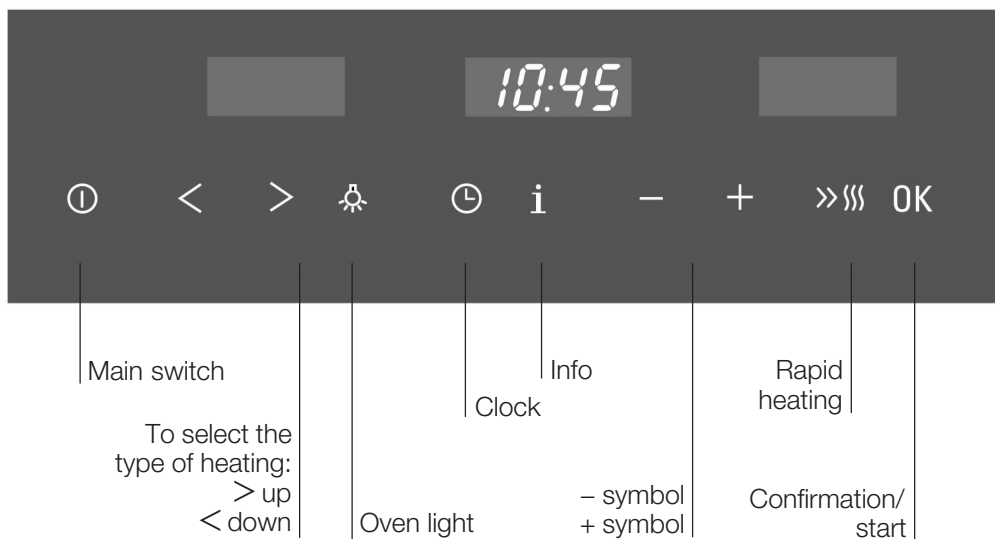

Control panels and displays

There are sensors underneath the individual control panels. Touch the relevant symbol with your index finger.

Symbol		
ⓘ	Main switch	This is used to switch the oven on and off.
<>	Arrows for selecting the type of heating	Use these arrows to select the type of heating: > up < down
💡	Oven light	Use this symbol to switch the oven light on and off.
🕒	Clock	Use this symbol to set the time, the timer ⏰, the duration → and the end time → .
i	Info	You can use this symbol to call up the heating temperature and the weight set for the automatic program.
- +	Symbols for adjusting the values set	Use these symbols to adjust the default values and values set: - symbol = to set a lower value + symbol = to set a higher value
»»»	Rapid heating	Use this symbol to heat up the oven quickly.
OK	Confirmation/start	Use this symbol to confirm a setting or to start the oven.

The values set can be seen in the display. Settings can be made as long as a symbol in the display is flashing.

Important

The setting will be cleared after a few minutes if you do not start the oven using the OK symbol. Always start the oven using the OK symbol.

The rise in temperature or the residual heat in the oven is shown in the preheating indicator below the temperature display.

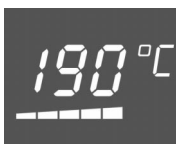

Arrows for selecting the type of heating

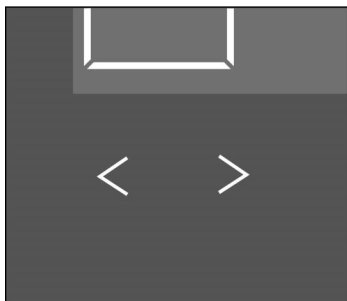

You can select the type of heating for the oven using the > up or < down arrows.

Touch the relevant arrow until the type of heating required appears in the display.

A default value appears in the temperature display for each type of heating.

Settings

	Top/bottom heating
	Conventional baking*
	Intensive heat
	3D hot air
	Intensive hot air/pizza setting
	Bottom heating
	Hot air grilling
	Radiant grill - small area
	Radiant grill - large area
	Defrost
P	Automatic program

*Type of heating with energy efficiency class determined in accordance with EN50304.

Oven light

The oven light switches on when you select a type of heating.

Exception:

The light does not come on during defrosting at temperatures between 30 and 60 °C.

If the oven is set to switch on and off automatically, the oven light will only come on after the oven is switched on.

You can switch the light off and on again using the oven light symbol.

Exception: Defrosting at 20 °C.

Symbols for adjusting the values set

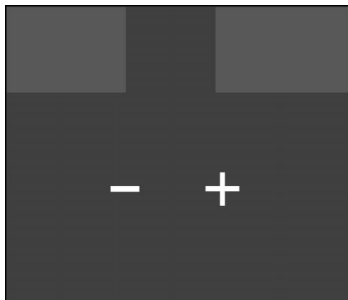



You can adjust all default values and values set using the + symbol or – symbol.

+ = to set a higher value

– = to set a lower value

Ranges

50 - 300	Temperature in °C Maximum temperature for 3D hot air  and intensive hot air/pizza setting  = 270 °C Defrost at temperatures between 20 and 60 °C
1 - 3	Grill levels
1 min - 23.59 h	Duration
1 sec - 23.55 h	Timer period
P 1 - P 26	Programs

Types of heating

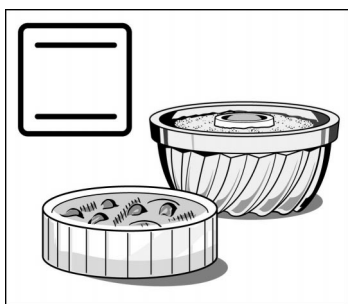

Different types of oven heating are available. You can therefore select the best method for cooking any dish.

Top and bottom heating

This ensures the even distribution of heat onto the cake or roast from the top and bottom of the oven.

This type of heating is best for cake mixtures in tins or for bakes. Top and bottom heating is also suitable for cooking lean roasts of beef, veal and game.

Gentle cooking in the 70 °C to 100 °C temperature range makes all tender meat particularly juicy.

To keep food warm : You can keep food warm in the 65-100 °C temperature range. Do not keep food warm for longer than two hours.

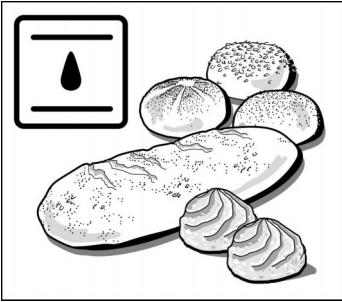

Conventional baking

is the most energy-efficient type of heating. This type of heating also ensures even distribution of heat to the food from the top and bottom of the oven. The moisture extracted during the baking is retained as steam in the oven. The food does not dry out. Leavened food such as bread, bread rolls or plaited loaves turn out especially well when cooked using this type of heating. This type of heating is also best for cooking choux pastries such as cream puffs.

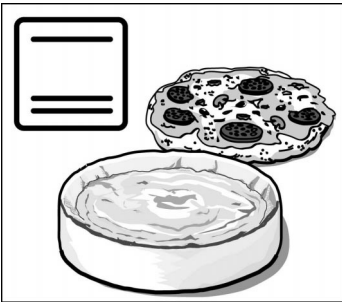

Intensive heat

Due to the intensive heat from below, foods such as pizza will acquire a particularly crispy base. It is no longer necessary to preheat the oven to bake spiced cakes and savoury pies such as quiche lorraine. Intensive heat is also the ideal type of heating when baking in moulds made from tin, glass or porcelain, which tend to reflect heat or are poor conductors of heat.

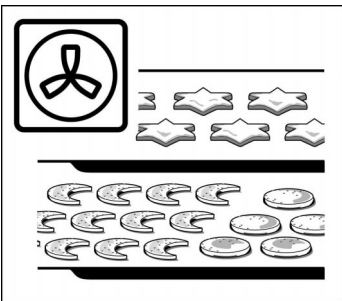

3D hot air

A fan in the rear panel distributes the heat from the ring heating element evenly inside the oven. Using 3D hot air, it is possible to bake cakes and pizza on two shelves. You can cook cookies and puff pastry on three levels at the same time. The required oven temperatures are lower than those for top and bottom heating. Additional baking trays may be obtained from specialist shops. 3D hot air is ideal for drying food.



Pizza setting/intensive hot air

This type of heating uses bottom heating and the ring heating element. This type of heating is particularly suitable for deep-frozen foods. It is ideal for cooking pizzas, chips or strudels, without requiring preheating.

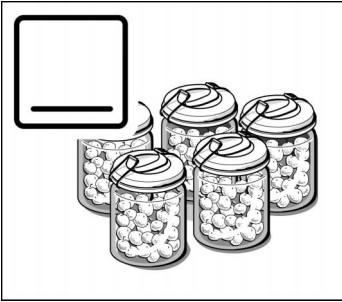

Bottom heating

You can reheat or brown meals using bottom heating. It is also the most suitable type of heating for preserving food.

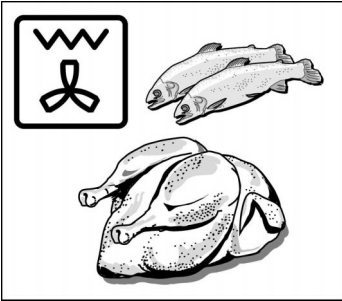

Hot air grilling

This type of heating involves the grill element and the fan alternating between on and off. During the pause in heating, the fan circulates the heat generated by the grill around the food. This ensures that cuts of meat are crisped and brown on all sides.

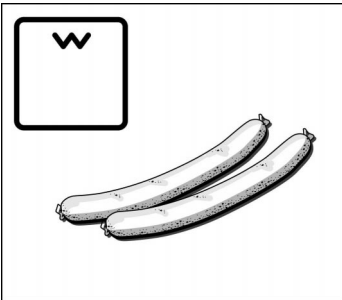

Radiant grilling, small area

This involves only the middle section of the grill heating element being switched on. This type of heating is ideal for cooking small quantities. This saves energy. Place the pieces to be grilled in the centre of the wire grill.

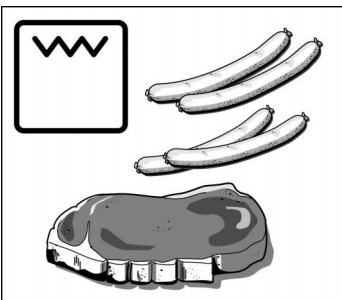

Radiant grilling, large area

The entire area under the grill element becomes hot. This is ideal if you wish to cook several steaks, sausages, fish or slices of toast.

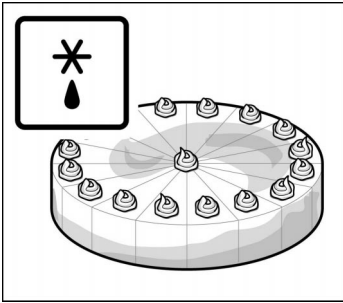

Defrost

A fan in the rear wall of the oven circulates the air in the oven around the frozen food. Frozen pieces of meat, poultry, bread and cakes defrost evenly.

Notes

Heating is interrupted if you open the oven door while the oven is in operation.

To ensure that the heat is well distributed, the fan switches on for a short time during preheating for types of heating with top and bottom heating.

Oven and shelving accessories

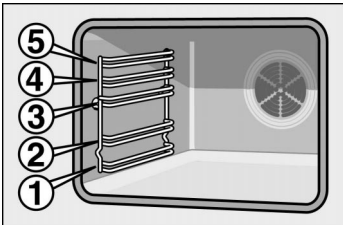

The shelf can be inserted at 5 different heights in the oven.

You can remove the shelf two thirds of the way without it tipping. This makes it easier to take food out of the oven.

Accessories

Accessories may be purchased at a later date from the after-sales service or from specialist shops. Please specify the HZ number.

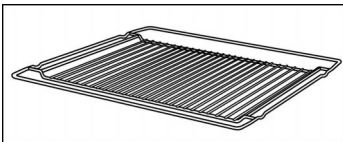

HZ 334000 wire rack

For ovenware, cake tins, roasts, grilling and frozen meals.

Insert the wire rack curving downwards .

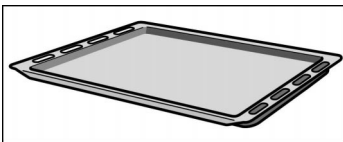

Enamel baking tray HZ 331000

for cakes and biscuits.

Push the baking tray with the sloping edge facing towards the oven door.

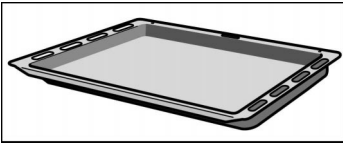

Universal pan 332000

for moist cakes, pastries, frozen food and large roasts. It can also be used to catch dripping fat when you are grilling directly on the wire grill.

Push the universal pan with the sloping edge facing towards the oven door.

Optional accessory

Optional accessories may be purchased from the after-sales service or from specialist shops.

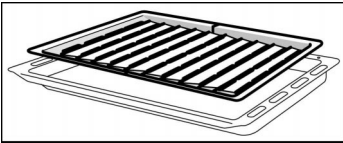

Grill pan HZ 325000

Can be used for grilling instead of the wire grill or as a spray guard to protect the oven against dirt. Only use the grill pan in the universal pan.

To grill using the grill pan: use the same shelf height as for the wire grill.

Using the grill pan as a spray guard: insert the universal pan with the grill pan under the wire grill.

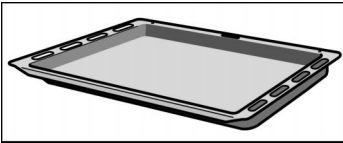

Universal pan HZ 332010 with non-stick coating

Moist cakes, biscuits, frozen meals and large roast joints come away from the universal pan more easily.

Push the universal pan with the sloping edge facing towards the oven door.

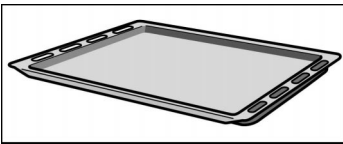

Enamel baking tray HZ 331010 with non-stick coating

Cakes and biscuits can be removed from the baking tray more easily.

Push the baking tray with the sloping edge facing towards the oven door.

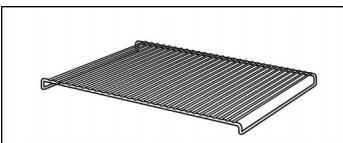

HZ 324000 wire rack

for grilling. Always place the wire grill in the universal pan. Fat and meat juices are collected.

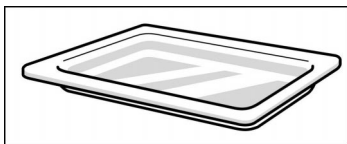

Glass pan HZ 336000

A deep baking tray made from glass. Can also be used as a serving dish.

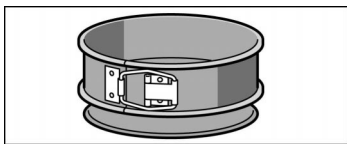

Baking tin HZ 26001

You can bake especially moist cakes using the leak-proof baking tin. The extra wide rim prevents leakage and your cooker stays clean. The baking tin has a non-stick coating on the inside.

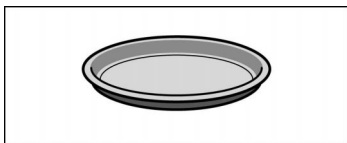

Pizza tray HZ 317000

Ideal for pizza, frozen foods and large round cakes, for example. You can use the pizza tray instead of the universal pan. Place the tray on the wire grill. Observe the information provided in the tables.

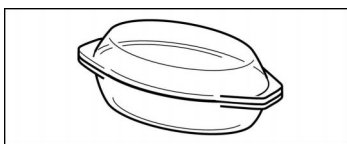

Glass roasting dish HZ 915000

for braised dishes and bakes that are cooked in the oven. It is especially suitable for the automatic roasting function.

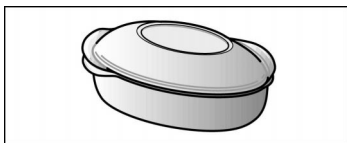

Metal roasting dish HZ26000

It is intended for use in the extended cooking zone of the glass ceramic hob. The dish is suitable for the sensor cooking system as well as for the automatic roasting function. The roasting dish is enamel on the outside and has a non-stick coating on the inside.

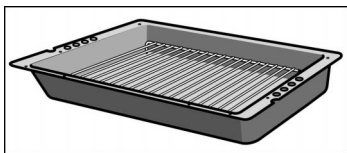

Profi extra-deep pan HZ 333000

for cooking large quantities of food.

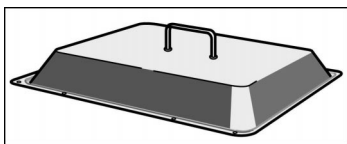

Lid for the Profi extra-deep pan HZ 333001

Converts the Profi extra-deep pan into the Profi roasting dish.

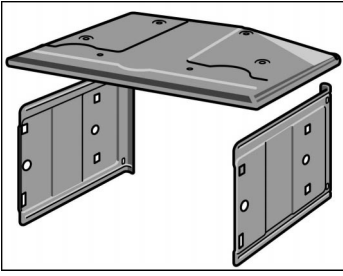

Self cleaning oven roof and side walls (ecoClean) HZ 329022

You can retrofit your cooker with these. The oven cleans itself while it is in operation.

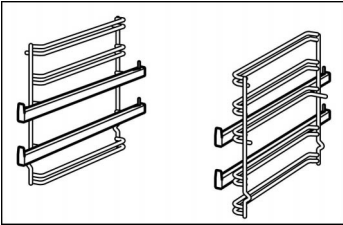

2 tier telescopic shelf HZ 338200

The ledges at heights 2 and 3 allow you to pull the shelf out further without it tipping.

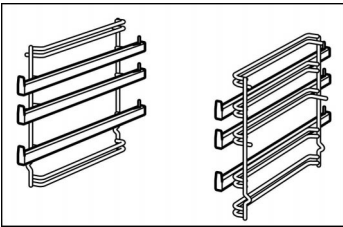

3 tier telescopic shelf HZ 338300

The ledges at heights 2, 3 and 4 allow you to pull the shelf out further without it tipping.

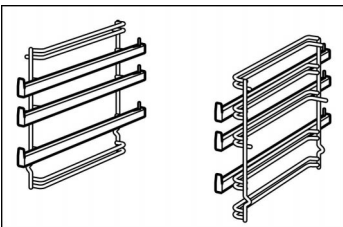

3 tier telescopic shelf HZ 338305

The ledges at heights 2, 3 and 4 allow you to pull the shelf out further without it tipping.

Cooling fan

The oven is fitted with a cooling fan. It switches itself on and off as necessary. The warm air escapes above the door.

Before using for the first time



This section tells you everything you need to do before using the cooker for the first time.

Heat the oven and clean the accessories. Read the safety instructions in the “Important information” section.

Firstly, check to see if the  symbol and three zeros are flashing in the display.

If the  symbol and three zeros are flashing in the display





Set a time.

1. Touch the  clock symbol.
12:00 appears and the  clock symbol flashes in the display.
2. Set the current time with the – or + symbol.
3. Confirm with the OK symbol.
The oven is ready for operation.

Heating up the oven

Heat the empty oven with the door closed to remove the new oven smell.

Method

1. Touch the  main switch until the  symbol appears in the display.
2. Set  top/bottom heating. To do this, touch the > up arrow until the  symbol appears in the display.
3. Touch the + symbol until 240 °C appears in the temperature display.
4. Start the oven by touching the OK symbol.

Switch the oven off after 60 minutes using the  main switch.

Pre-cleaning the accessories

Please wash the accessories thoroughly with soapy water and a cleaning cloth before using them.

Switching the oven on and off

Main switch

Switching on

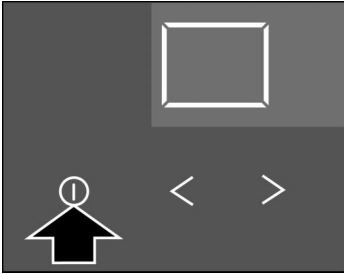

The ① main switch is used to switch the oven on and off.

Touch the ① main switch until the □ symbol appears in the display.

The main switch switches off automatically if you do not set the oven within the next few minutes. The □ symbol goes out.

Switching off

Touch the ① main switch until the setting disappears.

The time, any timer period set and, if applicable, the residual heat indicator are independent of the main switch.

Setting the oven

Switching off the oven manually

You have various options for setting the oven.

When your meal is ready, switch off the oven yourself.

The oven switches off automatically

You can leave the kitchen for a long period.

The oven switches on and off automatically



You can put your meal in the oven in the morning, for example, and set the oven so that your meal is ready at midday.

Tables and tips

The correct settings for many dishes can be found in the Tables and tips section.

Setting procedure

Example: Top/bottom heating , 190 °C

1. Switch on the  main switch. The  symbol lights up in the display.
2. Set the required type of heating with the < down or > up arrow.

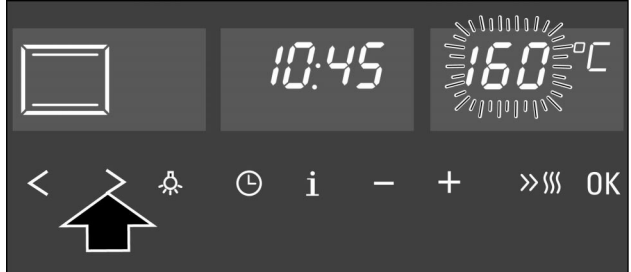

3. Set the desired temperature or grill setting with the - or + symbol.

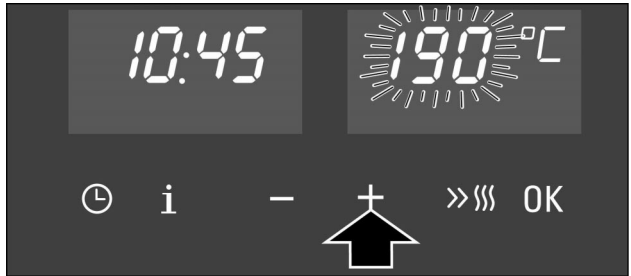

4. Start the oven by touching the OK symbol.



Short beep

If you forget to start the oven, a short beep reminds you after a few seconds that you must touch the OK symbol to start.

Switching off

Switch off the  main switch when the meal is ready.

Changing the setting

You may change the type of heating, temperature or grill setting at any time. Confirm the change by touching the OK symbol.

Preheating indicator





The preheating indicator provides a visual display of the oven temperature increase. It is best to insert the dish in the oven when all segments are lit.

The preheating indicator does not appear during grilling and defrosting (20 °C).

While the oven is heating up, you can call up the current heating temperature with the **i** Info button. It appears in the display for a few seconds. The heating temperature does not appear if you are grilling.

The thermal inertia of the oven means that a temperature may be displayed during the heating up phase which differs from the actual oven temperature.

You want the oven to switch off automatically

5. Touch the  clock symbol repeatedly until the  duration symbol flashes in the display.

Set as described in points 1 to 4. Set the duration (cooking time) for your meal.

Example: for a duration of 45 minutes



6. Set the required duration with the – or + symbol.

+ plus
default value = 30 min.
– minus
default value = 10 min.



7. Start with the OK symbol or extend the end time, as described under the section entitled “You want the oven to switch on and off automatically”.

The  duration symbol lights up in the display when you start the oven by touching the OK symbol.

The duration has elapsed

A signal sounds. The oven switches off. 0:00 is shown in the clock display. You can cancel the signal in advance by touching the ⌚ clock symbol. The time appears again when you switch off the Ⓜ main switch.

Clearing the duration

Touch the ⌚ clock symbol repeatedly until the ⌚→ duration symbol flashes. Touch the – symbol until zero appears in the display. Touch the OK symbol. The oven is interrupted if it is in operation.

Changing the setting

Touch the ⌚ clock symbol. Change the duration with the + or – symbol. Confirm with the OK symbol.

Cancelling the setting

Switch off the Ⓜ main switch.

Calling up settings

To call up the end time →| or time ⌚: touch the ⌚ clock symbol until the relevant symbol appears in the display. The value called up will then appear in the display for a few seconds.

You want the oven to switch on and off automatically

Please remember that foods which spoil easily must not be allowed to remain in the oven for too long.

Example: the time is 10:45. The meal will take 45 minutes to cook and must be ready at 12:45 pm.

Set the oven as described in steps 1 to 6. The oven should not be switched on yet.

7. Touch the ⌚ clock symbol.
The ⌚→ end time symbol flashes.
In the display you will see the time when the meal will be ready.



8. Extend the end time with the + symbol.



9. Confirm with the OK symbol.

The display will show the end time until the oven is switched on. The duration then counts down in the display.

The duration has elapsed

A signal sounds. The oven switches off. 0:00 is shown in the clock display. The time appears again when you switch off the ⓐ main switch.

Note

You can change the settings as long as a symbol in the display goes out. When the symbol lights up, the setting has been adopted. You can change the time before which a setting is adopted. See the Basic settings section for more details.

Residual heat indicator

When you switch off the oven, the residual heat in the oven is indicated in the preheating indicator. When all segments are lit, the temperature in the oven is approximately 300 °C.

The preheating indicator goes out when the temperature has fallen to approximately 60 °C.

Using the residual heat







You can keep food warm in the oven using the residual heat.

For meals with long cooking times, you may switch off the oven 5 to 10 minutes earlier. The residual heat will finish cooking the meal, thereby saving energy.

Rapid heating

This allows you to preheat the oven particularly quickly.

You may use the rapid heating function with the following types of heating:

-  = Top/bottom heating
-  = Conventional baking
-  = Intensive heat
-  = 3D hot air
-  = Pizza setting
-  = Hot air grilling

Method

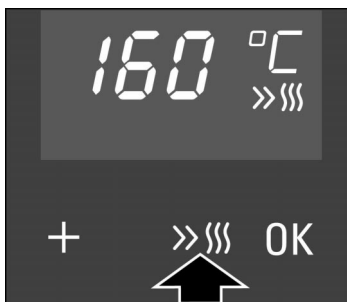

Cancelling the rapid heating function

Notes

Set the oven as required.

Touch the »»» rapid heating symbol.

The »»» symbol lights up in the temperature display.

The oven will heat up. The segments of the preheating indicator will light up.

When all segments of the preheating indicator are lit, a signal sounds and the »»» symbol goes out. Place the food in the oven.

Touch the »»» rapid heating symbol. The »»» symbol goes out in the temperature display.

The rapid heating function will not work if the temperature set is below 100 °C. If the temperature in the oven is only slightly below the temperature set, the rapid heating function is not necessary. It will not switch on.

The rapid heating function is interrupted if you change the type of heating.

You can call up the current heating temperature during rapid heating. Touch the **i** Info symbol. The temperature appears for several seconds in the display.

Automatic program

Using the automatic program, you will be able to produce delicious braised meals, juicy roasts and tasty stews without the need for turning or basting the meat which, in turn, keeps your oven clean.

Ovenware

The automatic program is only suitable for roasting in a covered dish. Only use a roasting dish with a suitable lid.

Suitable dishes

Suitable dishes are heat-resistant (up to 300 °C), glass or glass ceramic dishes.

Add more liquid when roasting in enamelled steel, cast-iron or pressed aluminium dishes. The base of the pan should be covered by liquid to at least ½ cm. The food will brown more.

Please observe the instructions of the dish manufacturers.

Stainless steel dishes are only suitable in some cases. The food will not brown as much and the meat will not cook as well.

Unsuitable dishes

Dishes made of shiny aluminium, unglazed clay or dishes with plastic handles are not suitable.

Dish size

The meat should cover around two thirds of the base of the dish. This ensures that the meat juices turn out well.

There should be at least 3 cm between the meat and the lid. The meat may expand while roasting.

Preparing food

Select a suitable dish.

Weigh the fresh or deep-frozen meat, the fish or the vegetables if it is a vegetarian dish. You need this weight to adjust cooking times etc.

Cover the dish with the lid. Place it on the wire grill at shelf position 2.

Meat

If indicated in the program table, add liquid to the empty dish. The base of the dish must be covered.

Season meat, place it in the dish and close with the lid.

Fish

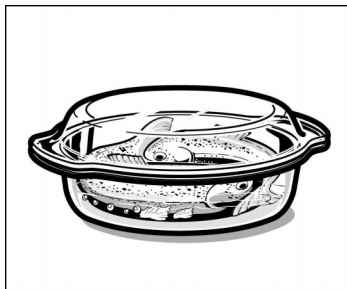

Clean the fish and add lemon juice and salt to taste.

Steamed fish: Add the fluid, e.g. wine or lemon juice, to a depth of ½ cm.

Baked fish: Toss the fish in flour and coat with melted butter.

Note: Fish cooks best when placed in the “swimming position” in the dish.

Stew

You can combine different kinds of meat and fresh vegetables.

Cut the fish into bite-size pieces. Do not cut up chicken portions.

Add up to twice the amount of vegetables to meat.
Example: Use between 0.5 kg and 1 kg fresh vegetables for 0.5 kg meat.

Always put the meal into the cold oven.

Programs

Fresh meals	Use for	Program number	Weight range	Add liquid
Beef: pot-roast	Spare ribs, shoulder, sides, braised marinated beef	01	0.5-3.0 kg	Yes
Sirloin		02	0.5-2.5 kg	No
Sirloin, rare		03	0.5-2.5 kg	No
Roast pork	Neck, collar, sides, thick flank, fillet	04	0.5-3.0 kg	Yes
Roast pork with crackling	Shoulder with rind, belly	05	0.5-2.0 kg	No
Ham		06	0.5-2.5 kg	Yes
Leg of lamb	Boned	07	0.5-2.5 kg	Yes

Fresh meals	Use for	Program number	Weight range	Add liquid
Leg of lamb, medium rare	Boned	08	0.5-2.5 kg	No
Poultry	Chicken, duck, goose, baby turkey	09	0.5-2.5 kg	No
Poultry drumsticks	Chicken, turkey, duck, goose drumsticks	10	0.3-1.5 kg	No
Turkey breast	Turkey breast, fillet	11	0.5-2.5 kg	Yes
Mutton, venison	Shoulder, neck, breast	12	0.5-2.5 kg	Yes
Gammon, venison, sm.game	Leg of venison, leg of hare	13	0.5-3.0 kg	Yes
Meat loaf	Beef/pork meatloaf	14	0.3-3.0 kg	No
Stews	Roulade, meat and vegetable stew, Szegedin goulash	15	0.3-3.0 kg	Yes
Steamed fish	Trout, pike-perch, carp, whole cod	16	0.3-1.5 kg	Yes
Baked fish	Trout, pike-perch, carp, whole cod	17	0.5-1.5 kg	No

Frozen meals*	Use for	Program number	Weight range	Add liquid
Beef: pot-roast	Spare ribs, shoulder, sides	18	0.5-2.0 kg	Yes
Beef, medium	Roast beef, spare rib	19	0.5-2.0 kg	No
Roast pork	Neck, collar, sides, thick flank, fillet	20	0.5-2.0 kg	Yes
Roast veal	Shoulder, shank, thick flank, topside, stuffed breast of veal	21	0.5-2.0 kg	Yes
Leg of lamb	Boned	22	0.5-2.0 kg	Yes
Leg of lamb, med. rare	Boned	23	0.5-2.5 kg	No
Poultry drums	Chicken, turkey, duck, goose drumsticks	24	0.3-1.5 kg	No
Mutton, venison	Shoulder, neck, breast	25	0.5-2.0 kg	Yes
Small game	Leg of venison, leg of hare	26	0.5-2.0 kg	Yes

* Important: If preparing frozen meat, extending the end time is not recommended. The meat would thaw out before the program starts and would be inedible.

How long will the meal take to cook?

So that you know how long the meal will take to cook, set the oven as described in steps 1 to 6. The duration will appear in the display.

To interrupt the program: change the type of heating or switch off the ① main switch.

Setting procedure

Select the appropriate program from the program table.

Example: well-done roast beef, 1.2 kg, program P2.

1. Switch on the ① main switch.
2. Select the automatic program with the > up or < down arrow. P appears in the display.

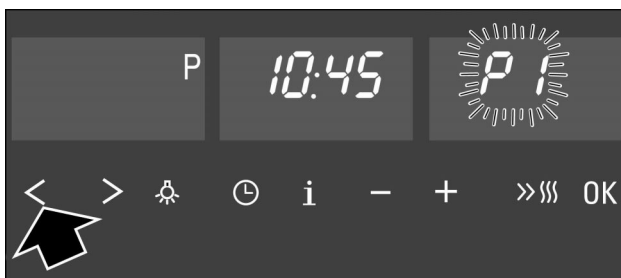

3. Set the program number required with the + symbol.



4. Confirm with the OK symbol. The default weight appears in the clock display.

5. Set the weight with the + or – symbol.



6. Confirm with the OK symbol.

7. Start the program with the OK symbol or extend the end time as subsequently described.

The duration has elapsed

A signal sounds. The oven switches off. The time appears again when you switch off the Ⓛ main switch.

Cancelling the program

Change the type of heating or switch off the Ⓛ main switch.

You want the oven to switch on and off automatically

Only use fresh meat or fresh fish.

Do not leave the food to stand in the oven for too long. Meat and fish will spoil easily when not in the refrigerator.

Example: program P2. You want the meal to be ready by 12:15.

Set the oven as described in steps 1 to 6.

7. While the set program is flashing, touch the Ⓛ clock symbol until the → end time symbol flashes.

In the display you will see the time when the meal will be ready.

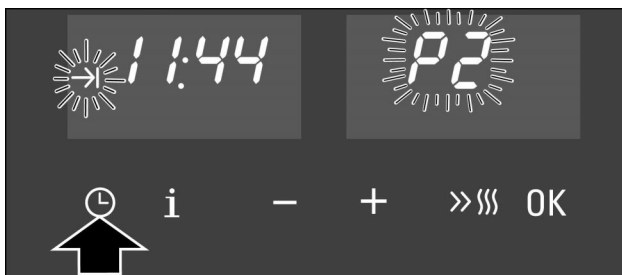

8. Extend the duration with the + symbol.



9. Confirm with the OK symbol.

The end time is shown in the display. The →| end symbol lights up. The oven switches on at the appropriate time.

The duration has elapsed



A signal sounds. The oven switches off. The time appears again when you switch off the ⌚ main switch.

Note

To call up the weight: Touch the i Info symbol. The weight appears for a few seconds in the display after the program has started.

Tips on the automatic program

The weight of meat or poultry exceeds the specified weight range

The weight range is deliberately limited. It is rare to find roasting dishes of sufficient size for cooking large pieces of meat. Cook large pieces of meat using top/bottom heating  or hot air grilling .

The meat is good, but the juices are too dark

Use a smaller dish and more liquid.

The meat is good, but the juices are too clear and watery.

Use a larger dish and less liquid.

The top of the roast is too dry.	Use a roasting dish with a firmly fitting lid. Very lean meat stays juicier if it is covered with bacon rashers.
While the meat is roasting, it smells as though it is burning even though the meat looks good.	The lid on the roasting dish is not properly closed or the meat has risen and raised the lid. Always use a suitable lid. Ensure that there is a minimum distance of 3 cm between the meat and the lid.
You want to cook frozen meat	Season the frozen meat in exactly the same way as fresh meat. N.B. The end time cannot be set to a later time if cooking meat from frozen. The meat would defrost before the program starts.
You want to roast several chicken drumsticks or other poultry drumsticks at the same time	The drumsticks must be of approximately the same size. Enter the weight of the heaviest drumstick. Example: Two turkey drumsticks weighing 1.4 and 1.5 kg. Enter 1.5 kg.
You want to poach or bake several fish at the same time	The fish must be approximately the same size. Enter the total weight. Example: Two trout weighing 0.6 and 0.5 kg. Enter 1.1 kg.
You want to cook stuffed poultry	This method of cooking is not suitable for stuffed poultry. This is best cooked uncovered on the wire grill. Look up poultry in the table.
The meat in the stew is not sufficiently browned	Next time place the pieces of meat around the edge of the dish. Place the vegetables in the middle.
The vegetables in the stew are too hard	When cooking a stew, enter the weight of the meat. This ensures that the vegetables are crunchy. If you want the vegetables to be softer, enter the combined weight of the vegetables and meat.
You want to cook a vegetarian stew	Only use firm vegetables, such as carrots, green beans, white cabbage, celery and potatoes. The smaller you cut the vegetables, the softer they will be. Cover the vegetables with liquid to prevent them from browning excessively.
You wish to use your stainless steel roasting dish	The stainless steel dish is only suitable to a certain degree. The shiny surface reflects much of the heat radiation. The meal will not brown as much and the meat will be less well done. If you use the stainless steel roasting dish: Remove the lid once the program has ended. Grill the meat at grill setting 3  for a further 8 to 10 minutes.

Time

When the oven is first connected or following a power cut, the ⌚ symbol and three zeros flash in the display. Set a time.

Setting procedure

Example: 13:00

1. Touch the ⌚ clock symbol. 12:00 appears in the display and the ⌚ symbol flashes.

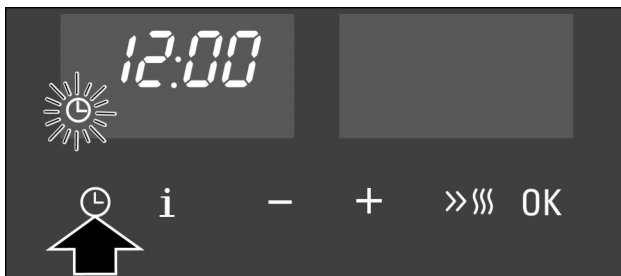

2. Adjust the time using the – or + symbol.



3. Confirm by pressing OK. The time appears. The ⌚ symbol will go out.

Changing the time e.g. from summer to winter time

The oven must be switched off. Touch the ⌚ clock symbol repeatedly until the ⌚ symbol flashes in the display. Adjust the time using the – or + symbol. Confirm by pressing OK.

Hiding the time

You can adjust the setting for the time so that it is only shown when the oven is in operation. To do this, you must change the basic setting. See the Basic settings section.

Timer

You can use the timer as a kitchen timer. It operates independently of the oven.
The timer has a special signal.

Setting procedure

Example: 20 minutes

1. Touch the ⌚ clock symbol repeatedly until the ⚠ timer symbol appears in the display.

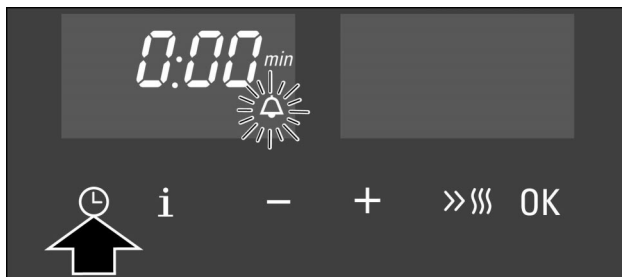

2. Set the timer period with the – or + symbol.

+ plus
default value = 10 min.
– minus
default value = 5 min.



3. Start the timer with the OK symbol.
The time counts down visibly.

The time has elapsed

A signal sounds. Touch the ⌚ clock symbol. The timer display will go out.

Changing the timer period

Touch the ⌚ clock symbol. The ⚠ symbol will flash.
Change the time with the + or – symbol.
Start with the OK symbol.

Cancelling the setting

If you switch off the main switch, the timer continues as set.

Touch the ⌚ clock symbol. Reset the time to 0:00 with the – symbol. Confirm with the OK symbol. The time reappears in the display.

The timer and duration count down simultaneously

Both symbols light up in the display. The timer period counts down in the display.

To call up the duration **I→I**, end time **→I** or time **⊖**: touch the **⊖** symbol repeatedly until the **I→I** or **→I** symbol or the time **⊖** appears.

The value called up will then appear in the display for a few seconds.

Basic settings

Your oven has several basic settings. You can adapt these settings to your own preferences.

	Function	Option 1	Option 2	Option 3
In 1	Time in the clock display	The time is always displayed.	The time is only shown when the oven is in operation*	-
In 2	Signal duration after a set time has elapsed	Short	Medium	Long
In 3	Adoption time for adjustment increments	Approximately 20 seconds	Approximately 30 seconds	Approximately 40 seconds
In 4	The cooling fan runs on until the oven reaches a certain temperature.	Short run-on time	Moderate run-on time	Long run-on time
In 5	Display brightness	Dim	Moderate	Bright
In 6	Audible signal when starting	Off	On	-

* Exception: The time is shown when the residual heat is displayed.

Changing the basic settings

1. Touch the **i** Info symbol until **In 1** appears in the display.

There must be no program set.

Example: The time is only shown when the oven is in operation.

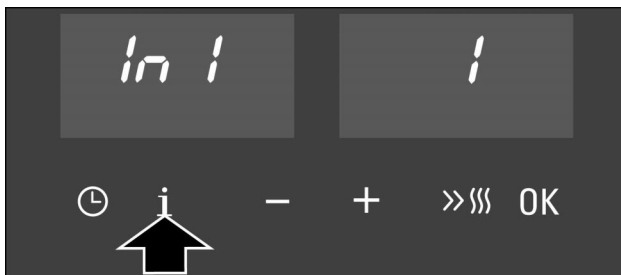

2. Adjust the basic setting using the + or – symbol.

All setting levels can be scrolled through using the **i** Info symbol and altered using the + or – symbol. Press OK to confirm that you have finished adjusting the settings.



Correction

You may change your settings again at any time.

Child-proof lock

The oven has a child-proof lock to prevent children switching it on accidentally or changing the setting.

Locking the oven

Touch the OK symbol until the  key symbol lights up in the display.

The oven can no longer be set. A setting cannot be changed.

N.B. The current setting will be deleted if you touch the  main switch symbol. The childproof lock remains activated.

Unlocking

Touch the OK symbol until the  key symbol in the display goes out.

Note

The  symbol will flash in the display if you attempt to make settings on the oven when the childproof lock is activated. Release the lock.

Automatic time limiter

If you have forgotten to switch off the oven, the automatic time limiter will be activated. Oven operation will be interrupted. The time when this happens depends on the selected temperature or grill setting.

A **5** appears in the display when the oven is no longer heating up. If the heating function is interrupted a signal sounds.

The heating function is interrupted until you switch off the  main switch. The **5** will disappear. Now you can reset the oven.

Cancelling the automatic time limiter

If you enter a duration, the oven will then switch off at the required time.

The time limiter is cancelled.

Care and cleaning

Do not use high-pressure cleaners or steam jets.

Oven exterior

Wipe the oven with water and a little washing-up liquid. Dry it with a soft cloth.

Caustic or abrasive substances are not suitable. If any such substances come into contact with the frontage, wipe it off immediately with water.

Note

Slight differences in the colours on the appliance front are caused by the use of different materials, such as glass, plastic and metal.

Shadows on the door panel which resemble smears are reflections from the oven light.

Appliances with stainless steel fronts

Always remove any flecks of limescale, grease, cornflour and egg white immediately. Corrosion can form under such flecks.

Use stainless steel care products. Follow the manufacturer's instructions. Try out the product on a small area first, before using on the whole surface.

Appliances with aluminium fronts

Use a mild window-cleaning detergent. Wipe the area with a soft window cloth or a fluff-free micro-fibre cloth, using a horizontal action without applying pressure.

Aggressive cleaning products, scratchy sponges and rough cleaning cloths are not suitable.

Oven

Never use coarse scouring pads or cleaning sponges. Oven cleaner may only be used on enamelled oven surfaces.

For ease of cleaning

you can fold down the grill element in the top of the oven.

Folding down the grill element

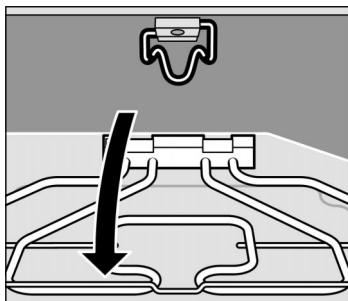
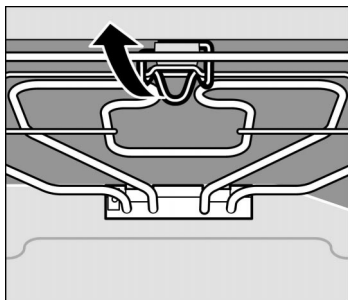

Fold down the grill element to facilitate cleaning of the oven cover.

Warning: the oven must be cold. There is a risk of burning.

Pull the handle on the folding grill towards the front and push it upwards until you hear it click into place. At the same time, hold the grill element and fold it down.

After cleaning:

Fold the grill element back up. Push the handle down until the grill element engages.

Cleaning the catalytic surfaces of the oven

The rear wall of the oven is coated with self-cleaning enamel. The surface cleans itself while the oven is in operation. Large splashes sometimes only disappear after the oven has been used several times.

Never use oven cleaner on the back wall of the oven.

Should the enamel become slightly stained, this will not affect its self-cleaning properties.

Cleaning the oven floor, the oven ceiling and the side walls

Use hot soapy water or a vinegar solution.

It is best to use oven cleaner if the oven is very dirty. Only use oven cleaner in a cold oven.

Never use oven cleaner on the self-cleaning rear wall of the oven.

Cleaning the glass cover for the oven light

Note:

Enamel is baked on at very high temperatures. This can cause some slight colour variation. This is normal and does not affect the function. Do not use coarse scouring pads or strong cleaning agents to remove such discolorations.



The edges of thin trays cannot be completely enamelled. As a result, these edges can be rough. Anti-corrosion protection is guaranteed.

It is best to clean the glass cover with washing-up liquid.

Self-cleaning oven roof and side walls

Changing the basic setting

If you retrofit self-cleaning coverings to your oven, you must change the basic setting for the coverings.

1. Select 3D hot air  with the < down or > up arrow.
2. Enter 85 °C with the – symbol.
3. Touch the  rapid heating symbol until 0 or a 1 is shown in the temperature display.
0 = “self-cleaning coverings not retrofitted”
1 = “self-cleaning coverings retrofitted”.
4. You can switch between the settings with the – or + symbol.
5. Confirm the setting with the OK symbol.

Checking the setting

Repeat steps 3 to 5.

Regenerating the self-cleaning oven back wall, roof and sides

It is possible to regenerate self-cleaning parts of the oven if self-cleaning is no longer as effective. The parts will then be fully operational again.

Remove accessories and ovenware from the oven.

Caution: The oven floor must be thoroughly cleaned beforehand. Otherwise stains may appear that cannot be removed.

1. Switch on the ① main switch.
2. Press the up arrow > to select 3D hot air 🌀.
3. Set a temperature of 270 °C using the + plus symbol.
4. Touch OK.
5. Touch the ⌚ clock symbol repeatedly until the I→I cooking time symbol flashes.
6. Set a time of 60 minutes using the + plus symbol.
7. Press OK to start cooking. The cooking time will appear in the display.

The oven will switch off automatically after one hour.

Cleaning the rails

The rails can be removed for cleaning.

To unhook the rails:

1. Lift the rail at the front in an upwards direction
2. and unhook it.
3. Then pull the whole rail forward and take it out.

Clean the rails using either washing-up liquid and a sponge or a brush.

To hook rails back into position:

First insert the rail in the rear socket, push it back slightly and then hook it into the front socket.

The rails fit both the left and right sides. Recess (a) must always be at the bottom.

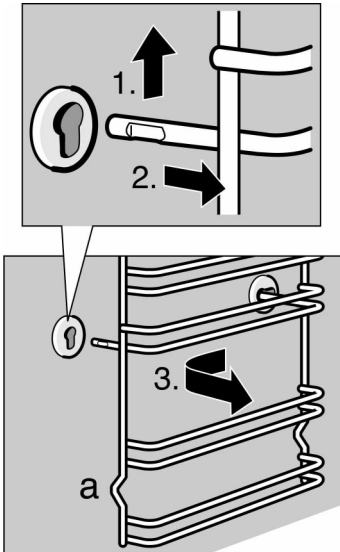

Cleaning the glass panels

The glass panels on the oven door can be removed to assist in cleaning.

Make sure when removing the inner glass panels that you replace the panels in the same order. Use the numbers on the panels to do this.

Removal

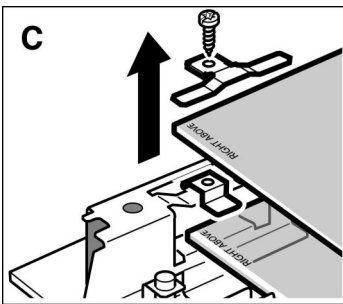
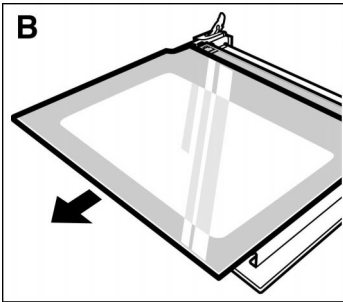
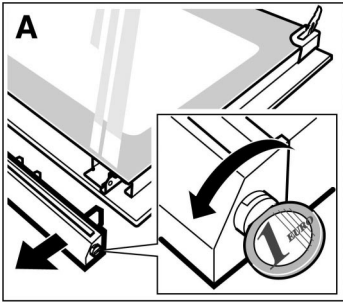

1. Remove the oven door and lay it down on a cloth with the handle facing downwards.
2. Unscrew the cover at the top of the oven door. To do this, undo the right and left-hand screws with a coin (Fig. A).
3. Raise the upper panel and remove it (Fig. B).

Points 4 and 5 depend on the cooker type

4. Unscrew the large clips on the left and right and remove them (Fig. C). Remove the middle glass panel.
5. Remove the small clips from the lower glass panel and remove the panel upwards at an angle (Fig. C).

Clean the glass panels with glass cleaner and a soft cloth.

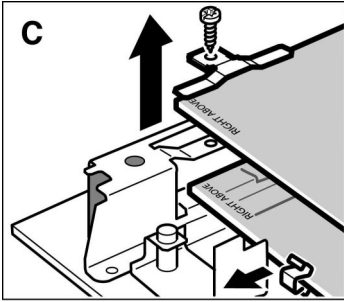

or

4. Unscrew the large clips on the left and right and remove them (Fig. C). Remove the middle panel.
5. Remove the small clips from the lower glass panel and remove the panel upwards at an angle (Fig. C).

Installation

Make sure that the message “Right above” is upside down at the bottom left of both panels.

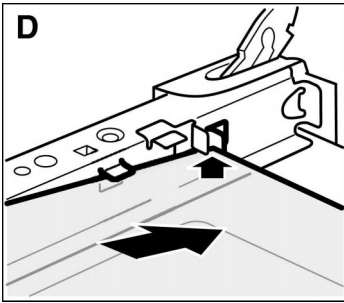

1. Slide in the lower glass panel at an angle towards the rear (Fig. D).
2. Put the small clips on the left and right-hand sides of the lower panel.

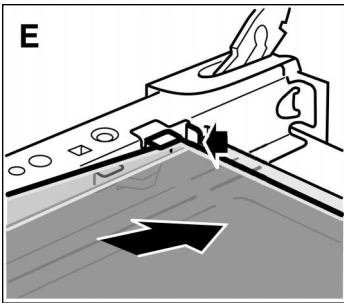

3. Insert the middle glass panel (Fig. E).

Points 4 and 5 depend on the cooker type

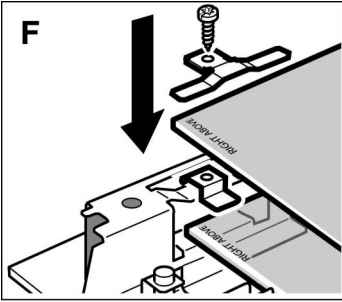

4. Put the small clips on the left and right-hand sides of the lower panel (Fig. F).
5. Position the large clips over the small clips, align them and screw them in place (Fig. F).

or

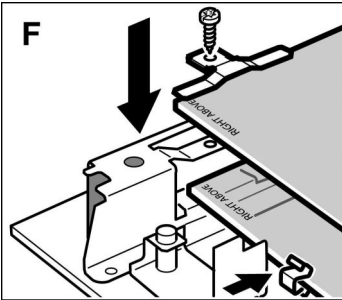

4. Replace the small clips back onto the bottom glass panel (Fig. F).
5. Fit the large clips and screw them in (Fig. F).

6. Insert the upper panel. The smooth surface must face outwards.
7. Replace the cover and screw it back on.
8. Refit the oven door.

The oven must not be used again until the panels have been correctly fitted.

Seal

Clean the seal on the oven with washing-up liquid. Never use caustic or abrasive detergents.

Accessories

Immediately after use, soak the accessories in washing-up liquid. Food residues can then be easily removed with a brush or sponge.

Steam filter

The oven cover features a steam filter. This filters out grease particles in the extracted air, thereby reducing odours.

The filter must be cleaned occasionally.

Method

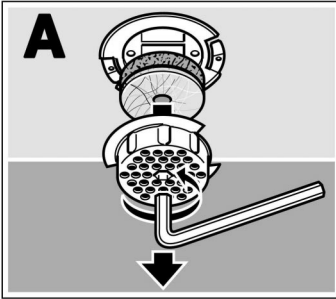

1. Using an Allen (6 mm), turn the filter head anticlockwise and remove. Figure A.

2. Remove both filter elements.

The filter head and the thin, single-layer filter element can be cleaned with washing-up liquid or washed in the cutlery basket of the dishwasher. You must not wash the thicker filter element. The coating could be damaged.

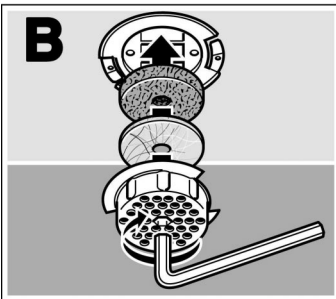



3. Place the single-layer filter element and then the double-layer filter element back in the filter head.

4. Insert the filter head and, using the Allen key, tighten it by turning it clockwise.

The filter head must be inserted as shown in Figure B. Only then can it be re-fitted securely.

Troubleshooting

Should a malfunction occur, it is often only due to a minor fault. Please read the following notes before calling the after-sales service.

Problem	Possible cause	Comments/remedy
The oven does not work.	Blown fuse.	Look in the fuse box to make sure that the fuse for the appliance is okay.
	Power cut	Check whether the kitchen light switches on.
	The oven is locked.	Touch the + and OK symbols simultaneously until the  key symbol goes out in the display.
The clock display flashes.	Power cut	Reset the time.
The oven does not heat up.	The oven door is not properly closed.	Close the oven door fully.
	The oven does not start heating.	Touch the OK symbol.
The oven does not heat up. A square appears in the temperature display.	The appliance is currently in demo mode.	Switch off the fuse in the fuse box. Wait for approximately 20 seconds. Switch on the fuse again. Within the next 2 minutes, press the rapid heating symbol for 6 seconds until the square in the display disappears.
A "5" appears in the clock display.	The oven was operated for a long period without the setting being changed. The automatic time limiter was activated.	Switch off the  main switch.

Problem	Possible cause	Comments/remedy
"E01" or "E04" appear in the display.	The temperature sensor has failed.	Contact the after-sales service.
"E02" appears in the display.	Faulty mains connection.	Switch off the fuse in the fuse box and connect the cooker properly.
"E03" appears in the display.	The electronic circuits have overheated.	The cooling fan is operating. "E03" will clear after cooling and the oven will continue heating.
"E05" appears in the display.	Communication error	Switch off the fuse in the fuse box, wait approximately 20 seconds and then switch it on again. Reset the time. If this error occurs frequently, call the after-sales service.
"E10" appears in the display.	Data error	Switch off the fuse in the fuse box, wait approximately 20 seconds and then switch it on again. Reset the time. If this error occurs frequently, call the after-sales service.
"E11" appears in the display.	A symbol was touched for too long.	Touch all control buttons individually. If the error message remains, please contact the after-sales service.
"E15" appears in the display.	The oven has become too hot.	Let the oven cool and then you will be able to operate it again. If this error occurs frequently, call the after-sales service.

Repairs may only be carried out by fully trained after-sales service technicians.

Incorrect repairs may result in serious injury to the user.

Replacing the oven light

If the oven light fails, it must be replaced. 40 watt heat-resistant spare bulbs can be obtained from the after-sales service or specialist shops. Only use these bulbs.

Method



1. Switch off the oven fuse in the fuse box.
2. Place a tea towel in the cold oven to prevent damage.
3. Unscrew the glass cover by turning it anti-clockwise.
4. Replace the oven light with one of the same type.
5. Screw the glass cover back on.
6. Remove the tea towel and switch the fuse back on.

Replacing the oven light

If the oven light fails, it must be replaced. 25 watt heat-resistant spare bulbs can be obtained from the after-sales service or specialist shops. Only use these bulbs.

Method

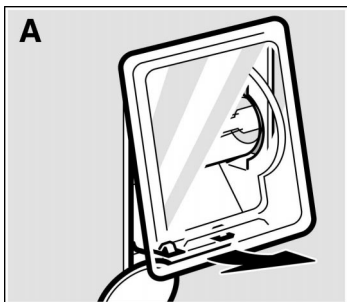

1. Switch off the oven fuse in the fuse box.
2. Place a tea towel in the cold oven to prevent damage.
3. Remove the glass cover. To do this, open the glass cover at the bottom with your hand. Figure A.
If the glass cover is difficult to remove, use a spoon to help you.

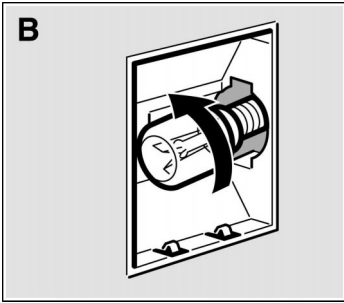

4. Unscrew the bulb and replace it with one of the same type. Figure B.

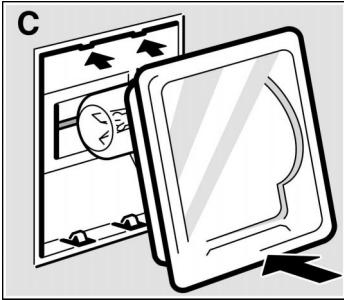

5. Fit the glass cover back on. Ensure that the curvature in the glass is on the right. Insert the glass cover at the top and press it firmly on at the bottom. Figure C. The glass cover will now click into place.
6. Remove the tea towel and switch the fuse back on.

Replacing the glass cover

The glass cover on the oven light must be replaced if it is damaged. Replacement glass covers may be obtained from the after-sales service. To this end, please specify the E number and FD number of your appliance.

After-sales service

Our after-sales service is there for you if your oven needs repairing. You will find the address and telephone number of your nearest after-sales service centre in the phone book. The after-sales service centres listed will also be happy to advise you of a service point in your area.

E number and production number

Please quote the E number (product number) and the FD number (production number) of your appliance when contacting the after-sales service. The rating plate bearing these numbers is found on the side of the oven door. You can make a note of these numbers in the space below to save time in the event of your appliance malfunctioning.

E no.	FD no.
After-sales service ☎	

Packaging and old appliances

Disposing in an environmentally-responsible manner



Unpack the appliance and dispose of the packaging in an environmentally-responsible manner.

This appliance is labelled in accordance with the European Directive 2002/96/EG concerning used electrical and electronic appliances (waste electrical and electronic equipment – WEEE).

The guideline determines the framework for the return and recycling of used appliances as applicable.

Tables and tips

This table contains a selection of dishes and the optimum settings at which to cook them. You can find out which type of heating and temperature is best for your dish, which accessories to use, and at which oven level the dish should be inserted. You will find a variety of tips about ovenware and preparation, and a small troubleshooting section in case anything should go wrong.

Cakes and pastries

Baking on one level

If you are baking cakes on one level, you should use top/bottom heating . This will give the best results for your cakes.

Baking tins

It is best to use dark baking tins. You should use 3D hot air when using thin baking tins, or glass containers. This means, however, that the baking time is increased and the cake does not brown so evenly.

Always place the cake tin on the wire grill.

If you are cooking using three tins at the same time, position these as illustrated.

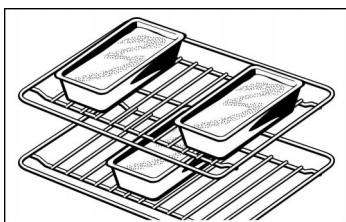

Tables











The values in the table apply to dishes placed in a cold oven. This saves energy. Shorten the baking times indicated by 5 to 10 minutes if you have preheated the oven.

The tables show which type of heating is best for different cakes and bakes.

The temperature and cooking time you select depends on the quantity and type of pastry. This is why “ranges” are given in the tables. You should try to use a lower temperature setting to start with, since this allows more even browning. If necessary, use a higher temperature setting the next time.











Note: Condensation may form on the inner pane in the oven door as a result of the high moisture content created when cooking using  conventional baking. Steam escapes when you open the oven door.

More information can be found in the “Baking tips” section which follows the tables.



Cakes in tins	Tin on the wire grill	Level	Type of heating	Temperature in °C	Baking time in minutes
Sponge cake, simple	Round/Vienna ring/ rectangular tin	2		160-180	50-60
	3 cake tins*	1+3		140-160	70-100
Sponge cake, delicate (e.g. pound cake)	Round/Vienna ring/ rectangular tin	2		140-160	60-70
	3 cake tins*	1+3		140-160	70-100
Short pastry base with edge	Springform cake tin	1		170-190	25-35
Cake base made from sponge mixture	Fruit cake base	2		160-180	20-30
Sponge cake	Springform cake tin	2		160-180	30-40
Fruit cake or cheesecake, short crust pastry**	Non-stick springform cake tin	2		170-190	70-90
Fruit cake, fine sponge mixture	Springform cake tin/ bowl mould	2		160-180	50-60
Savoury bakes** (e.g. quiche/onion tart)	Springform cake tin	1		200-220	40-50

* Please position the tins correctly. Additional wire grills may be obtained as optional accessories from specialist shops.











** Allow cakes to cool in the oven for approximately 20 minutes.

Cakes on the tray		Level	Type of heating	Temperature in °C	Baking time in minutes
Sponge or yeast pastry with dry topping	Baking tray	2		170-190	20-30
	Baking tray + universal pan*	2+4		150-170	35-45
Sponge or yeast pastry with fruit topping	Universal pan	3		170-190	40-50
	Baking tray + universal pan*	2+4		140-160	50-60
Swiss roll (preheat)	Baking tray	2		170-190	15-20
Plaited loaf made with 500 g flour	Baking tray	2		170-190	25-35
Stollen made with 500 g flour	Baking tray	3		160-180	60-70
Stollen made with 1 kg flour	Baking tray	3		150-170	90-100
Strudel, sweet	Universal pan	2		190-210	55-65
Pizza	Baking tray	2		190-210	25-35
	Baking tray + universal pan*	2+4		170-190	40-50

* Always place the universal pan above the tray when you are cooking on two levels at once.

Bread and rolls		Level	Type of heating	Temperature in °C	Cooking time in minutes
Bread made from 1.2 kg flour* (preheat)	Universal pan	2		300	5
				190	30-40
Sour dough bread made from 1.2 kg flour* (preheat)	Universal pan	2		300	8
				200	35-45
Bread rolls (e.g. rye rolls)	Baking tray	4		200-220	20-30

* Never pour water directly into a hot oven.

Small baked products		Level	Type of heating	Temperature in °C	Baking time in minutes
Biscuits	Baking tray	3		150-170	10-20
	Baking tray + universal pan**	2+4		130-150	25-35
	2 baking trays* + universal pan***	2+3+5		130-150	30-40
Meringue	tray	3		80-100	100-150
Cream puffs	tray	2		210-230	30-40
Macaroons	Baking tray	2		110-130	30-40
	Baking tray + universal pan**	2+4		100-120	35-45
	2 baking trays* + universal pan***	2+3+5		100-120	40-50
Puff pastry	Baking tray	3		180-200	20-30
	Baking tray + universal pan**	2+4		180-200	25-35
	2 baking trays* + universal pan***	2+3+5		170-190	35-45

* Additional baking trays may be obtained as optional accessories from specialist shops.

** Always place the universal pan above the tray when you are cooking on two levels at once.

*** Insert the universal pan at the bottom of the oven. This can be removed before cooking.

Baking tips

You wish to cook to your own recipe.

Refer to the instructions in the tables for similar types of food.

How to check that a sponge cake is cooked properly.

Approximately 10 minutes before the end of the baking time given in the recipe, pierce the tallest point of the cake with a cocktail stick. The cake is done if the cocktail stick comes out clean.

The cake collapses.

Next time, use less liquid or decrease the oven temperature by 10 degrees. Observe the cooking times in the recipe.

The cake has risen in the centre but is lower at the edges.

Do not grease the sides of the springform cake tin. As soon as the cake is done, carefully loosen the cake around the edges using a knife.

The cake is too dark at the top.

Insert it at a lower level in the oven, select a lower temperature and cook the cake a little while longer.

The cake is too dry.

Use a toothpick to make small holes in the finished cake. Then drizzle fruit juice or alcohol over the top. Next time you should decrease the temperature by around 10 degrees and reduce the baking times.

The bread or cake (e.g. cheesecake) looks fine, but is soggy on the inside (soft, with watery areas).

Next time you should add a little less liquid and cook for a little longer at a lower temperature. Cakes with fruit topping: Precook the base first of all. Sprinkle with almonds or breadcrumbs and then place the topping over this. Please observe the recipe and the baking times.

The pastry is unevenly browned.

Select a slightly lower temperature to ensure that the pastry is baked more evenly. Delicate pastry should be baked on one level using top/bottom heating . Baking paper that protrudes over the food can affect the air circulation. For this reason, always cut the baking paper to fit the baking tray.

The fruit cake is too light at the bottom. The fruit juice flows over.

Use the deeper universal pan next time.

You were baking on several levels. The food on the top baking tray is darker than that on the bottom baking tray.

Always use 3D hot air  when baking on several levels. Baking trays that are placed in the oven at the same time will not necessarily be ready at the same time.

Condensation is formed when baking cakes containing fresh fruit.

Baking may result in the formation of water vapour. It escapes above the door handle. The steam may settle and form water droplets on the control panel or on the fronts of adjacent units. This is a normal physical process.

Meat, poultry, fish

Ovenware

You may use any heat-resistant dishes. The universal pan is also suitable for larger roasts.

Always place the dishes in the centre of the wire grill.

Hot glass dishes should be placed on a dry kitchen towel after being removed from the oven. The glass could crack if placed on a cold or wet surface.

Advice on roasting

The roasting result depends on the type and quality of meat.

Add 2 to 3 soup spoons of liquid to lean meat, and 8 to 10 soup spoons of liquid to pot roasts, depending on the size.

Meat should be turned half way through the cooking time.

When the roast is ready, switch off the oven and leave the roast to stand for 10 minutes with the oven door closed. This allows the meat juices to distribute more favourably.

Advice on grilling

Always close the oven door when grilling.

If possible, use pieces of meat which are of the same thickness. They should be at least 2 to 3 cm thick. Such pieces will be browned evenly and stay juicy and soft in the middle. Only salt the steaks after they have been grilled.





















Place the pieces of meat directly onto the wire grill. If you are grilling just one piece of meat, it will turn out best if you place it in the centre of the wire grill. You should also insert the universal pan at level 1. The meat juices are collected here and the oven is kept clean.

Turn the pieces of meat after two thirds of the cooking time indicated.

The grill element automatically switches itself off and back on again. This is normal. The number of times this happens depends on the grill setting you have selected.

Meat

The table applies to insertion into a cold oven. The time specifications are provided as guidelines only and depend on the type and quality of the meat.

Meat	Weight	Ovenware	Level	Type of heating	Temperature in °C, grill	Cooking time in minutes
Beef pot roast (e.g. ribs)	1 kg		2		200-220	100
	1.5 kg	Covered	2		190-210	120
	2 kg		2		180-200	140
Sirloin of beef	1 kg		2		200-220	80
	1.5 kg	Uncovered	2		190-210	90
	2 kg		2		180-190	100
Sirloin, medium-rare*	1 kg	Uncovered	1		230-240	60
Steaks, well done		Wire rack***	5		3	20
Steaks, medium rare		Wire rack***	5		3	15
Pork without rind (e.g. neck)	1 kg		1		190-210	120
	1.5 kg	Uncovered	1		180-200	150
	2 kg		1		170-190	170
Pork with rind** (e. g. shoulder, leg)	1 kg		1		190-210	130
	1.5 kg	Uncovered	1		180-200	160
	2 kg		1		170-190	190
Smoked pork on the bone	1 kg	Covered	2		210-230	70
Meat loaf	750 g	Uncovered	1		180-200	70
Sausage	approx. 750 g	Wire rack***	4		3	12
Roast veal	1 kg	Uncovered	2		180-200	110
	2 kg		2		160-180	130
Leg of lamb without bone	1.5 kg	Uncovered	1		160-180	120

* Turn roast beef after half the cooking time. After cooking, wrap the sirloin in aluminium foil and leave in the oven to stand for 10 minutes.

** Make cuts in the pork rind and place the pork in the dish if the pork is to be turned, first place the pork with the rind side down.

*** Insert the universal pan at level 1.

Poultry

The table applies to dishes placed in a cold oven.







The weights indicated in the table refer to oven-ready poultry (without stuffing).

If you are grilling directly on the wire rack, you should also insert the universal pan at level 1.

Pierce the skin of duck or goose under the wings to enable the fat to run off.





Turn whole poultry after two thirds of the grilling time.

Poultry will turn out particularly crispy and brown if you baste it towards the end of the roasting time with butter, salted water or orange juice.

Poultry	Weight	Ovenware	Level	Type of heating	Temperature in °C	Cooking time in minutes
Chicken halves, 1 to 4	400 g each	Wire rack	2		210-230	40-50
Chicken pieces	250 g each	Wire rack	2		210-230	30-40
Whole chickens, 1 to 4	1 kg each	Wire rack	2		200-220	50-80
Duck	1.7 kg	Wire rack	2		180-200	90-100
Goose	3 kg	Wire rack	2		160-180	110-130
Young turkey	3 kg	Wire rack	2		180-200	80-100
2 turkey drumsticks	800 g each	Wire rack	2		180-200	90-110

Fish

The table applies to dishes placed in a cold oven.

Fish	Weight	Ovenware	Level	Type of heating	Temperature in °C, grill	Cooking time in minutes
Grilled fish	300 g each	Wire grill*	2		2	20-25
	1 kg		2		200-220	40-50
	1.5 kg		2		190-210	50-60
Sliced fish (e.g. steaks)	300 g each	Wire grill*	3		2	20-25





* Insert the universal pan at level 1.





Tips for roasting and grilling

The table does not contain specifications for the weight of the roast.	Select the next lowest weight from the instructions and extend the time.
How can you tell when the roast is ready.	Use a meat thermometer (available from specialist stores) or implement a “spoon test”. Press a spoon onto the roast. If it feels firm, it is ready. If it can be pressed in, it needs to be cooked for a little longer.
The roast is too dark and the crackling is partly burnt.	Check the insertion level and temperature.
The roast looks good, but the sauce is burnt.	Next time, use a smaller roasting dish and add more liquid.
The roast looks good, but the sauce is too light and watery.	Next time, use a larger roasting dish and add less liquid.
Steam rises from the roast when the stock is added.	Most escapes through the steam outlet, some may condense on the cool control panel front or the surrounding cabinets where it will drip off. This will be dependent on the physical conditions.

Bakes, gratins, toast

The table applies to dishes placed in a cold oven.

Meal	Ovenware	Level	Type of heating	Temperature in °C, grill	Cooking time in minutes
Sweet bakes (e.g. quark and fruit bake)	Casserole dish	2		170-190	50-60
Savoury bakes made from cooked ingredients (e.g. pasta bake)	Casserole dish, universal pan	2		210-230	30-40
		2		210-230	20-30
Savoury bakes made from raw ingredients* (e.g. potato gratin)	Casserole dish or universal pan	2		160-180	50-60
		2		160-180	50-60

Meal		Ovenware	Level	Type of heating	Temperature in °C, grill	Cooking time in minutes
Toast	4 pieces	Wire rack	5		3	6-7
	12 pieces		5		3	4-5
Toast with topping	4 pieces	Wire rack**	4		3	7-10
	12 pieces		4		3	5-8















* The bake must be no higher than 2 cm.

** Always insert the universal pan at level 1.

Frozen foods

Please observe the instructions on the packaging.

The values in the table apply to dishes placed in a cold oven.

Meal	Use for	Level	Type of heating	Temperature in °C	Cooking time in minutes
Pizza*	Pizza with a thin base	2		200-220	15-25
	Pizza with a thick base	2		180-200	20-30
	Pizza baguette	2		180-200	20-30
	Mini pizza	2		190-210	10-20
Potato products*	Chips	2		200-220	20-30
	Duchess potatoes	2		200-220	20-30
	Fried potatoes	2		200-220	20-30
	Filled potato skins	2		200-220	15-25
Baked goods*	Rolls	3		190-210	10-20
	Pretzels	3		200-220	10-20
Fried foods*	Fish fingers	2		200-220	5-15
	Chicken nuggets	2		200-220	10-25
	Vegetable burgers	2		200-220	15-30
Strudel*	Apple strudel	3		190-210	30-40

* Line the universal pan with greaseproof paper. Please ensure that the greaseproof paper is suitable for use at these temperatures.



Slow cooking

Slow cooking is the ideal cooking method for all tender pieces of meat which are to be cooked rare or very rare. The meat remains very juicy and turns out as soft as butter. Advantages: The benefit of this cooking method is that it allows lots of scope for menu planning because slow-cooked meat is easy to keep warm.

Suitable dishes

Use a shallow dish, e.g. a porcelain serving dish.

Method

1. Touch the  main switch.
2. Select top/bottom heating  using the  up arrow.
3. Touch the – symbol until 90 °C appears.
4. Preheat the oven and also warm up a serving dish on the wire rack at shelf position 2.
5. Heat a little fat in a pan to a high temperature. Sear the meat over a high heat and then place directly on the warmed plate.
6. Put the dish with the meat back into the oven and complete the cooking. For most pieces of meat a cooking completion temperature of 90 °C is ideal.
7. Touch the OK symbol to start the oven.

Notes on slow cooking

Only use perfectly fresh meat for this.

Sear the meat at a very high temperature and for a sufficient amount of time.

When completing the cooking in the oven, do not cover the meat.

The meat should not be turned even if it is a large joint.

The meat can be cut immediately after slow cooking. It is not necessary to leave the meat to stand.

This particular cooking method always leaves the inside of the meat medium rare. However, this does not mean that it is raw or not cooked properly.

Table

All tender joints of beef, pork, veal and lamb are suitable for slow cooking. The length of time for searing and completing are worked out according to the size of the piece of meat.

The times for searing refer to the meat being inserted in hot fat.

Meal	Searing on the hotplate (time in minutes)	Completing in the oven (time in minutes)
Small pieces of meat		
Cubes or strips	1-2 all over	20-30
Small cutlets, steaks or médaillons	1-2 per side	35-50
Medium-sized pieces of meat		
Whole fillet (400 - 800 g)	4-5 all over	75-120
Saddle of lamb (approx. 450 g)	2-3 per side	50-60
Double cutlet	7-9 all over	100-120
Large pieces of meat		
Whole fillet (over 900 g)	6-8 all over	120-150
Roast (600 g - 1 kg)	8-10 all over	120-150
Roast (1.1 - 2 kg)	8-10 all over	180-270

Tips on slow cooking

Meat that has been cooked using slow cooking is not as hot as meat that has been cooked conventionally.





Warm the plates and serve the sauce at a high temperature.

If you want to keep slow-cooked meat warm.

Turn the temperature down to 70 °C after slow-cooking. Small pieces of meat can be kept warm for up to 45 minutes, and large pieces for up to two hours.

Special meals

You can set temperatures of up to 300 °C with this cooker. This makes it particularly good for cooking crispy pizzas or savoury flans. Just try it.

	Ovenware	Level	Type of heating	Temperature in °C	Cooking time
Preheat	Pizza dish or universal pan	1		300	7-12 Minutes
Pizza	universal pan	3		300	7-12 Minutes
Savoury flans (yeast dough with thin topping)					
Meat in pastry (preheat to 280 - 300 °C)	Universal pan	2		170-190	110-120 Minutes
750 g to 1 kg of meat and the same amount of bread dough.					
Fish, whole, 2 kg (e.g. fresh salmon)	Rack*	2		280-300 95	10 Minutes 50-60 Minutes

Place the prepared fish on the wire grill. Preheat the oven to 280-300 °C, sear the fish for 10 minutes at this temperature, and then lower the temperature to 95 °C.

* Insert the universal pan at level 1.

Defrosting

Remove the food from its packaging and place it in a suitable dish on the wire grill.

Please observe the instructions on the packaging.

The defrosting times depend on the type and amount of food.

Meal	Accessories	Level	Type of heating	Temperature in °C
Delicate frozen foods e.g. cream gateaux, cream cakes, cakes with chocolate or icing, fruit etc.	Wire rack	2		20 °C

Meal	Accessories	Level	Type of heating	Temperature in °C
Other frozen foods* Chicken, sausage and meat, bread, bread rolls and other pastries	Wire rack	2		50 °C

* Cover frozen food with microwave foil. Place poultry onto the plate with the breast side down.





In the 30 to 60 °C range, the oven light remains switched off. This gives best control.

Drying

Only use perfectly fresh fruit and vegetables, and wash them thoroughly.

Allow the food to drain well and dry it yourself.

Line the universal pan and wire rack with baking paper or greaseproof paper.

Meal	Level	Type of heating	Temperature in °C	Cooking time in hours
600 g apple rings	2 + 4		80	Approx. 5
800 g sliced pears	2 + 4		80	Approx. 8
1.5 kg prunes or plums	2 + 4		80	Approx. 8 - 10
200 g fresh herbs, washed	2 + 4		80	Approx. 1½

Note

Very moist fruit or vegetables should be turned several times. Once dried, remove the food from the paper immediately.

Preserving

Preparation

The jars and rubber sealing rings must be clean and intact. Use jars of the same size if possible. The instructions in the table refer to round 1-litre jars. Caution Do not use larger or taller jars. The lid could crack.



Only use perfectly fresh fruit and vegetables. Wash them thoroughly.

Pour the fruit or vegetables into the jars. Wipe clean the tops of the jars again if necessary. They must be clean. Place a wet rubber sealing ring and lid on each jar and lock the jars using clamps.

Do not place more than six jars in the oven.

The times specified in the tables are guidelines only. They can be influenced by the room temperature, the number of jars and the amount and temperature of the jar contents. Before you change settings or switch off the appliance, make sure that the contents of the jars are actually bubbling.

Setting procedure

1. Place the universal pan on level 2. Place the jars inside the pan so that they do not come into contact with each other.
2. Pour ½ litre of hot water (approx. 80 °C) into the universal pan.
3. Close the oven door.
4. Touch the  main switch.
5. Set bottom heating  using the downward arrow .
6. Touch the + symbol until 170 - 180 °C appears in the display.
7. Start the oven by touching the OK symbol.

Preserving fruit

As soon as the contents of the jars begins to simmer, that is when small bubbles appear at short intervals - after about 40 to 50 minutes - turn off the  main switch.

The jars should be removed from the oven after being reheated for 25 to 35 minutes. If the food is left to cool in the oven for longer, bacteria might form, accelerating spoilage of the preserved fruit.

Fruit in 1-litre jars	After bubbling	Reheating
Apples, red/blackcurrants, strawberries	Turn off	Approx. 25 minutes
Cherries, apricots, peaches, gooseberries	Turn off	Approx. 30 minutes
Apple purée, pears, plums	Turn off	Approx. 35 minutes

Preserving vegetables

As soon as the contents of the jars begin to simmer, set the temperature back to approximately 120 to 140 °C. Start by touching the ok symbol again. The table shows when you can switch off the oven: Allow the vegetables to stand in the oven for a further 30-35 minutes.

Vegetables with cold stock in 1-litre jars	After bubbling 120-140 °C	Reheating
Cucumbers	-	Approx. 35 minutes
Beetroot	Approx. 35 minutes	Approx. 30 minutes
Brussel sprouts	Approx. 45 minutes	Approx. 30 minutes
Beans, kohlrabi, red cabbage	Approx. 60 minutes	Approx. 30 minutes
Peas	Approx. 70 minutes	Approx. 30 minutes

Remove the jars

Never place the hot jars on a cold or wet surface as this could cause the glass to crack.

Energy saving tips

Only preheat the oven if it specifies in the recipe or in the table in the instruction manual that you should do so.

Use non-stick, black painted or enamelled tins. They absorb the heat especially well.

If you have several cakes to bake it is best to bake them one after the other. The oven is still warm. This shortens the baking time for the second cake. You can also put two baking tins in one after the other.

For long cooking times, the oven can be switched off 10 minutes before the end of the cooking time and the remaining heat can be used to finish the cooking.

Acrylamide in food

Experts are currently discussing how dangerous acrylamide in food can be. We have compiled this information sheet for you on the basis of current research.

Where does acrylamide come from?

Acrylamide in food does not come from external contamination. It is formed in the food itself during preparation - provided that the food contains carbohydrate and protein. Exactly how this happens has not yet been completely explained. However, it appears that the acrylamide content is strongly influenced by:

- high temperatures
- a low water content in food
- intensive browning of the food.

What sort of foods are affected?

Acrylamide forms mostly in grain and potato products that are prepared at high temperatures, e.g.:

- crisps, chips,
- toast, rolls, bread,
- baked goods made from shortcrust pastry (speciality biscuits and cakes).

What can you do?

You can avoid high levels of acrylamide when baking, frying and grilling.

The following recommendations were published by AID¹ and BMVEL² to help you minimise acrylamide levels:

In general

Keep cooking times as short as possible.

“Brown rather than burn” - cook food only until it is golden brown.

The larger and thicker the food is, the less acrylamide it contains.

Baking

Set the temperature to a maximum of 200 °C when using the top/bottom heating setting, and to a maximum of 180 °C for the 3D hot air setting.

Cookies: Set the temperature to a maximum of 190 °C when using the top/bottom heating setting, and to a maximum of 170 °C for the 3D hot air setting. The presence of egg or egg yolk in a recipe reduces the formation of acrylamide.

Spread oven chips evenly over the baking sheet in one layer where possible. To prevent the food from drying out quickly, place at least 400 g on each baking sheet.

¹ AID “Acrylamide” information leaflet, published by AID (German Evaluation and Information Service for Nutrition, Agriculture and Forestry) and BMVEL (German Federal Ministry for Consumer Protection, Food and Agriculture), as at 12/02, Internet: <http://www.aid.de>.











² BMVEL press release 365, as at 4.12.2002, Internet:<http://www.verbraucherministerium.de>

Test dishes

In accordance with DIN 44547 and EN 60350

Baking

The values in the table apply to dishes placed in a cold oven.

Meal	Accessories and notes	Level	Type of heating	Temperature in °C	Baking time in minutes
Viennese whirls	Baking tray	3		160-180	20-30
	Baking tray + universal pan**	2+4		140-160	30-40
	2 baking trays* + universal pan***	2+3+5		140-160	40-50
Small cakes x 20	Tray	5		3	1-2
Small cakes, 20 per baking tray (preheat)	Baking tray + universal pan**	2+4		140-160	25-35
	2 baking trays* + universal pan***	2+3+5		140-160	30-40
Swiss roll	Springform cake tin	2		160-180	30-40
Yeast cakes on a baking tray	Universal pan	3		170-190	40-50
	Baking tray + universal pan**	2+4		140-160	50-60
German apple pie	2 wire racks* + 2 tinplate springform cake tins Ø 20 cm****	2+4		180-200	70-80
	Universal pan + 2 tinplate springform cake tins Ø 20 cm****	1		190-210	70-80

* Baking trays and wire racks may be obtained as optional accessories from specialist shops.



** Always place the universal pan above the tray when you are cooking on two levels at once.

*** Always insert the universal pan at the bottom of the oven. This can be removed before cooking.

**** Place the cakes diagonally on the accessories.

Grilling

The values in the table apply to dishes placed in a cold oven.

Meal	Accessories	Level	Type of heating	Grill setting	Cooking time in minutes
Toast (preheat for 10 mins.)	Wire rack	5		3	1-2
Beefburgers, x 12*	Wire rack	4		3	25-30

* Turn after $\frac{2}{3}$ of the time has elapsed. Always insert the universal pan at level 1.

