

**SIEMENS**



## Fridge-freezer KI86FH...

[siemens-home.bsh-group.com/welcome](https://siemens-home.bsh-group.com/welcome)

en User manual

Register  
your  
product  
online

## en Table of contents

 <b>Safety instructions</b> . . . . .	<b>4</b>	 <b>Operating the appliance</b> . . . . .	<b>12</b>
About these instructions . . . . .	4	Switching on the appliance . . . . .	12
Risk of explosion . . . . .	4	Switching off and disconnecting the appliance . . . . .	12
Risk of electric shock . . . . .	4	Setting the temperature . . . . .	12
Risk of cold burns . . . . .	4	Super cooling . . . . .	13
Risk of injury . . . . .	5	Super freezing . . . . .	13
Fire hazard/Danger due to refrigerants . . . . .	5	Holiday mode . . . . .	14
Fire hazard. . . . .	5	 <b>Alarm</b> . . . . .	<b>14</b>
Avoiding placing children and vulnerable people at risk . . . . .	5	Door alarm . . . . .	14
Damage to property. . . . .	6	Temperature alarm . . . . .	14
Weight . . . . .	6	 <b>Home Connect</b> . . . . .	<b>15</b>
 <b>Intended use</b> . . . . .	<b>6</b>	Setting up Home Connect . . . . .	15
 <b>Green living</b> . . . . .	<b>6</b>	Installing updates for the Home Connect software. . . . .	18
Packaging . . . . .	6	Information on data protection . . . . .	18
Old appliances . . . . .	6	Declaration of Conformity. . . . .	18
 <b>Installation and connection</b> . . . . .	<b>7</b>	 <b>Refrigerator compartment</b> . . . . .	<b>19</b>
Scope of supply. . . . .	7	Note when storing food . . . . .	19
Technical specifications. . . . .	7	Note the chill zones in the refrigerator compartment . . . . .	19
Installing the appliance . . . . .	7	 <b>Cool-fresh compartment</b> . . . . .	<b>20</b>
Cavity dimensions . . . . .	7	Vegetable container . . . . .	20
Side by-side installation . . . . .	7	Cool-fresh container . . . . .	20
Tips for saving energy . . . . .	8	Storage times at 0 °C . . . . .	20
Before using the appliance for the first time. . . . .	9	 <b>Freezer compartment</b> . . . . .	<b>21</b>
Electrical connection . . . . .	9	Freezing small amounts of food . . . . .	21
 <b>Getting to know your appliance</b> . . . . .	<b>10</b>	Maximum freezing capacity . . . . .	21
Appliance. . . . .	10	Fully utilising the freezer volume . . . . .	22
Controls. . . . .	10	Purchasing frozen food . . . . .	22
Features. . . . .	11	When loading products, please note: . . . . .	22
		Freezing fresh food . . . . .	22
		Defrosting frozen food . . . . .	23

-  **Defrosting . . . . . 23**
  - Refrigerator compartment . . . . . 23
  - Freezer compartment . . . . . 23
-  **Cleaning . . . . . 24**
  - Cleaning the equipment . . . . . 24
-  **Odours . . . . . 25**
-  **Lighting. . . . . 25**
-  **Noises. . . . . 25**
  - Normal noises . . . . . 25
  - Preventing noises . . . . . 25
-  **What to do in the event of  
a fault . . . . . 26**
-  **Customer Service . . . . . 28**
  - Appliance self-test . . . . . 28
  - Obtaining advice and ordering  
repairs if a fault occurs. . . . . 28
  - Guarantee. . . . . 28

## Safety instructions

This appliance complies with the relevant safety regulations for electrical appliances and is fitted with noise suppression.

The refrigeration circuit has been checked for leaks.

### About these instructions

- Read and follow the instructions for installation and use. They contain important information on how to install, use and maintain the appliance.
- The manufacturer is not liable if you disregard the notifications and warnings in the operating and installation instructions.
- Retain all documents for subsequent use or for the next owner.

### Risk of explosion

- Never use electric appliances inside the appliance (e.g. heaters or electric ice makers).
- Do not store products which contain flammable propellant (e.g. spray cans) or explosive substances in the appliance.
- Keep high-percentage alcohol tightly sealed and store in an upright position.

- Do not use additional means to accelerate the defrosting process other than those recommended by the manufacturer.

### Risk of electric shock

Improper installations and repairs may put the user at considerable risk.

- When installing the appliance, ensure that the mains cable is not trapped or damaged.
- If the mains cable is damaged: immediately disconnect the appliance from the electricity supply.
- Do not use multi-outlet power strips, extension leads or adapters.
- Have the appliance repaired by the manufacturer, Customer Service or a similarly qualified person only.
- Use original parts supplied by the manufacturer only. The manufacturer guarantees that these parts satisfy the safety requirements.

### Risk of cold burns

- Never put frozen food straight from the freezer compartment into your mouth.

- Avoid prolonged contact between your skin and frozen food, ice or the tubes in the freezer compartment.

### Risk of injury

Containers which contain carbonated beverages may burst.

Do not store containers which contain carbonated beverages in the freezer compartment.



### Fire hazard/Danger due to refrigerants

The tubes of the refrigeration circuit convey a small quantity of an environmentally friendly but flammable refrigerant (R600a). It does not damage the ozone layer and does not contribute to the greenhouse effect. If refrigerant escapes, it may injure your eyes or ignite.

- Do not damage the tubes.

If the tubes are damaged:

- Keep naked flames and ignition sources away from the appliance.
- Ventilate the room.
- Switch off the appliance and pull out the mains plug.
- Please contact Customer Service.



### Fire hazard

Portable multi-outlet power strips or power supplies may overheat, causing a fire.

Never leave portable multi-outlet power strips or portable power supplies behind the appliance.

### Avoiding placing children and vulnerable people at risk

At risk here are:

- Children,
- People with limited physical, mental or sensory abilities,
- People who have inadequate knowledge concerning safe operation of the appliance.

Measures:

- Ensure that children and vulnerable people have understood the hazards.
- A person responsible for safety must supervise or instruct children and vulnerable people who are using the appliance.
- Only children aged 8 years and above may use the appliance.
- Supervise children who are cleaning and maintaining the appliance.
- Never allow children to play with the appliance.

## Risk of suffocation

- If the appliance features a lock: keep the key out of the reach of children.
- Keep children away from the packaging and its parts.

## Damage to property

To prevent damage to property:

- Do not stand or support yourself on the base, runners or doors.
- Keep plastic parts and door seals free of oil and grease.
- Pull on the mains plug – not the power cord.

## Weight

When installing and transporting the appliance, note that it may be very heavy.

→ *"Installation location" on page 7*



## Intended use

Use this appliance

- Only for the cooling and freezing of food and for making ice.
- Only in the home and in the home environment.
- Only according to this user manual.

This appliance is intended for use up to a maximum height of 2000 metres above sea level.



## Green living

### Packaging

All materials are environmentally safe and recyclable:

- Dispose of packaging in an environmentally friendly manner.
- Please ask your dealer or inquire at your local authority about current means of disposal.

### Old appliances

Valuable raw materials can be reclaimed by recycling old appliances.



#### Warning

**Children may become locked in the appliance and suffocate!**

- Leave shelves and containers in the appliance to prevent children from climbing in.
- Keep children away from the redundant appliance.

#### Caution!

**Refrigerant and harmful gases may escape.**

Do not damage the tubes of the refrigerant circuit or the insulation.

1. Pull out the mains plug.
2. Cut through the power cable.
3. Have the appliance disposed of properly.



This appliance is labelled in accordance with European Directive 2012/19/EU on waste electrical and electronic equipment (WEEE).

This Directive provides an EU-wide framework for returning and recycling old appliances.



## Installation and connection

### Scope of supply

After unpacking all parts, check for any damage in transit.

If you have any complaints, contact the dealer from whom you purchased the appliance or our Customer Service.

→ "Customer Service" on page 28

The delivery consists of the following parts:

- Built-in appliance
- Interior fittings (depending on model)
- Installation material
- User manual
- Installation instructions
- Customer service booklet
- Warranty enclosure
- Information on the energy consumption and noises

### Technical specifications

Refrigerant, cubic capacity and further technical specifications can be found on the rating plate.

→ "Getting to know your appliance" on page 10

### Installing the appliance

#### Installation location

The more refrigerant an appliance contains, the larger the room must be in which the appliance is situated. In rooms which are too small leaking refrigerant can form a flammable gas-air mixture.

Per 8 g of refrigerant the room must be at least 1 m<sup>3</sup> in size. The amount of refrigerant in your appliance is indicated on the rating plate inside the appliance.

→ "Getting to know your appliance" on page 10

The weight of the appliance may be up to 75 kg depending on the model.

#### Permitted room temperature

The permitted room temperature depends on the climate class of the appliance.

Information on the climate class can be found on the rating plate.

→ "Getting to know your appliance" on page 10

Climate class	Permitted room temperature
<b>SN</b>	+10°C ... 32°C
<b>N</b>	+16°C ... 32°C
<b>ST</b>	+16°C ... 38°C
<b>T</b>	+16°C ... 43°C

The appliance is fully functional within the permitted room temperature.

If an appliance with climate class SN is operated at colder room temperatures, the appliance will not be damaged up to a room temperature of +5°C.

### Cavity dimensions

#### Cavity depth

A cavity depth of 56 cm is recommended for the appliance. If the cavity depth is smaller – at least 55 cm – the energy consumption increases slightly.

#### Cavity width

An inside cavity width of at least 56 cm is required for the appliance. If this is not the case, problems may occur when installing the appliance.

### Side by-side installation

It is only possible to install appliances side by side with a gap of at least 15 cm.

## Tips for saving energy

If you follow the instructions below, your appliance will use less power.

**Note:** The arrangement of the features does not affect the energy consumption of the appliance.

Installing the appliance	
Keep the appliance out of direct sunlight.	The appliance must cool less frequently at low ambient temperatures and therefore consumes less power.
Install the appliance as far away as possible from heating elements, cooker and other heat sources: 3 cm to electric or gas cookers. 30 cm to an oil or solid-fuel cooker.	
Select an installation location at a room temperature of approx. 20 °C.	
Use a cavity depth of 56 cm. <b>Caution!</b> <b>Risk of burns!</b> Individual parts of the appliance become hot during operation. Touching these parts may result in burns.	The air on the rear panel of the appliance does not warm up so intensely. The appliance consumes less power if the warm air can escape.
Do not cover or block the ventilation openings.	
Ventilate the room daily.	
Using the appliance	
Open the appliance door only briefly.	The air in the appliance does not warm up so intensely. The appliance needs to cool less frequently and therefore consumes less power.
Transport purchased food in a cool bag and place in the appliance quickly.	
Allow warm food and drinks to cool down before placing in the appliance.	
Thaw frozen food in the refrigerator compartment to utilise the low temperature of the food.	
Always leave a space between the food and the back wall.	The air can then circulate and the humidity will remain constant. The appliance needs to cool less frequently and therefore consumes less power.
Pack food airtight.	
Do not cover or block the ventilation openings.	The air on the back wall of the appliance does not warm up so intensely. The appliance consumes less power if the warm air can escape.
Close the freezer compartment door carefully.	The freezer compartment will become covered in thick ice. If greater demands are made of the appliance, the power consumption will increase.



## Before using the appliance for the first time

1. Remove information material, adhesive tape and protective film.
2. Clean the appliance.  
→ "Cleaning" on page 24

## Electrical connection

### Caution!

Do not connect the appliance to electronic energy saver plugs.

**Note:** You can connect the appliance to mains-controlled and sine-controlled inverters.

Mains-controlled inverters are used for photovoltaic systems which are directly connected to the national grid.

Sine-controlled inverters must be used for isolated applications. Isolated applications, e.g. on ships or in mountain lodges, which are not directly connected to the national grid.

1. After installing the appliance, wait at least 1 hour before connecting it to avoid damaging the compressor.
2. Connect the appliance to a correctly installed socket.  
The socket must comply with the following data:  

Socket with	220 V ... 240 V
Protective conductor	50 Hz
Fuse	10 A ... 16 A

 Outside Europe: Check whether the indicated current type of the appliance corresponds with the values of your power supply. The appliance specifications are specified on the rating plate.  
→ "Getting to know your appliance" on page 10
3. Connect the appliance to a socket near the appliance.  
The socket must also be freely accessible after installation of the appliance.

### **Warning**

#### **Risk of electric shock!**

If the length of the mains cable is insufficient, do NOT use multi-outlet power strips or extension leads. Instead, please contact Customer Service for alternative solutions.

## Getting to know your appliance

Fold out the last page with the diagrams. The appliance and diagrams may differ according to features.

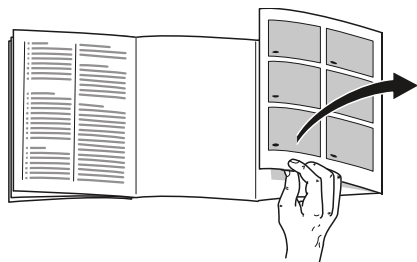

## Appliance

→ Fig. **1**

\* Not all models.

- A** Refrigerator compartment
- B** Cool-fresh compartment
- C** Freezer compartment
  
- 1**...**10** Controls
- 11** Lighting
- 12** Partition with humidity controller
  
- 13** Vegetable container
- 14** Cool-fresh container
- 15**\* Freezer container (flat)
- 16**\* Freezer drawer
- 17** Frozen food container (large)
  
- 18** Freezer container (small)
- 19** Rating plate
- 20** Butter and cheese compartment
- 21** Shelf for large bottles

## Controls

→ Fig. **2**

- 1** Button **⓪**  
Switches the appliance on or off.
- 2** Button **super** freezer compartment  
Switches Super freezing on or off.
- 3** Button **+/-** freezer compartment  
Sets the temperature of the freezer compartment.
- 4** Freezer compartment temperature display  
Indicates the set temperature in °C.
- 5** Button **alarm**  
Switches the warning signal off.
- 6** **hyperFresh 0 °C**  
Lights up when the appliance is in operation.
- 7**  button  
Switches Home Connect on or off.
- 8** Button **+/-** refrigerator compartment  
Sets the temperature of the refrigerator compartment.
- 9** Refrigerator compartment temperature display  
Indicates the set temperature in °C.
- 10** Button **super** refrigerator compartment  
Switches Super cooling on or off.

## Features

(not all models)

### Shelf

→ Fig. **3**

You can vary the shelf:

- Pull out and remove the shelf.

### Vario shelf

→ Fig. **4**

You can store tall items (e.g. cans or bottles):

- Take out the front part of the shelf and push under the rear part.

### Vegetable container

→ Fig. **5**

You can remove the container:

- Lift the container at rear and remove.

You can insert the container:

- Place the container on the telescopic rails and push into the appliance.

### Freezer tray

→ Fig. **6**

You can remove the tray:

1. Pull the container out all the way.
2. Lift tray and remove.

### Frozen food container

→ Fig. **7**

You can remove the container:

- Pull out the container all the way, lift at the front and remove.

## Storage compartment

→ Fig. **8**

You can remove the storage compartment:

- Lift up storage compartment and remove.

## Bottle holder

→ Fig. **9**

When you open and close the door:

- The bottle holder prevents the bottles from overturning.

## Ice cube tray

You can make ice cubes:

1. Fill the ice cube tray 3/4 full with water and place in the freezer compartment.
 

**Note:** If the ice cube tray is stuck to the freezer compartment, loosen with a blunt implement only (e.g. spoon handle).
2. To loosen the ice cubes, twist the ice cube tray slightly or hold briefly under flowing water.

## Ice pack

In the event of a power failure or a fault:

- The ice pack delays the warming of the stored frozen food.

**Note:** The longest storage time is obtained by placing the ice pack on the food in the top compartment.

You can take out the ice pack for temporarily keeping food cool, e.g. in a cool bag.



## Operating the appliance

### Switching on the appliance

1. Press the **ⓘ** button.  
The appliance begins to cool.  
Warning signal, flashing temperature display on the freezer compartment and lit button **alarm** indicate that the freezer compartment is still too warm.
2. Press the **alarm** button.  
The warning signal switches off.
3. Setting the required temperature.  
→ "Setting the temperature" on page 12

### Operating tips

- After the appliance has been switched on, it may take several hours until the set temperatures have been reached. Do not put in any food until the selected temperature has been reached.
- The fully automatic NoFrost system ensures that the freezer compartment remains free of ice. Defrosting is not required.
- The sides of the housing are heated slightly in certain areas. This prevents condensation in the area of the door seal.
- If the freezer compartment door cannot be immediately re-opened after it has been closed, wait until the resulting low pressure has equalised.

## Switching off and disconnecting the appliance

### Switching off the appliance

- Press the **ⓘ** button.  
The appliance no longer cools.

### Disconnecting the appliance

If you do not use the appliance for a prolonged period:

1. Press the **ⓘ** button.  
The appliance no longer cools.
2. Pull out the mains plug or switch off the fuse.
3. Clean the appliance.
4. Leave the appliance open.

### Setting the temperature

#### Recommended temperature

Refrigerator compartment:	+4 °C
Freezer compartment:	-18 °C

#### Refrigerator compartment

- Keep pressing the button **+/-** until the display indicates the required temperature.

#### Cool-fresh compartment

The temperature in the cool-fresh compartment is kept at around 0 °C.

**Note:** If frost forms on the food items in the cool-fresh compartment, set a higher temperature. → "What to do in the event of a fault" on page 26

#### Freezer compartment

- Keep pressing the button **+/-** until the display indicates the required temperature.

## Super cooling

Super cooling cools the refrigerator compartment to make it as cold as possible.

Switch on super cooling mode, e.g.:

- Before placing large quantities of food in the compartment
- For cooling beverages quickly

**Note:** When super cooling is switched on, increased operating noises may occur.

After 15 hours the appliance switches to normal operation.

Switching Super cooling on/off:

- Press the **super** button.  
The button is lit when Super cooling is switched on.

## Super freezing

### Automatic super freezing

Automatic super freezing automatically switches on when warm food is placed in the freezer.

With automatic super freezing the freezer compartment cools down to a much lower temperature than for normal mode.

Super freezing freezes food quickly right through to the centre.

**Note:** When automatic super freezing is switched on, the **super** button lights up and increased operating noise may occur.

Once the automatic super freezing has finished, the appliance automatically switches to normal mode.

Manually cancelling automatic super freezing:

- Press **super** button.

### Manual super freezing

Manual super freezing cools the freezer compartment as cold as possible.

Switch on super freezing mode, e.g.:

- to freeze food solid as quickly as possible
- 4 ... 6 hours before freezing food weighing 2 kg or more
- to use the max. freezing capacity  
→ "*Maximum freezing capacity*"  
on page 21

**Note:** When super freezing is switched on, increased operating noises may occur.

After approx. 2 ½ days, the appliance switches to normal operation.

Switching Super freezing on/off:

- Press the **super** button.  
The button is lit when Super freezing is switched on.

## Holiday mode

If leaving the appliance for a long period of time, you can switch the appliance over to the energy-saving holiday mode.

The temperature in the refrigerator compartment is automatically switched to +14 °C.

Do not store any food in the refrigerator compartment during this time.

The temperature in the freezer compartment remains unchanged.

Switch on holiday mode:

- Press button + refrigerator compartment until the display  shows **Ho**.

When holiday mode is switched on, the refrigerator compartment temperature display no longer indicates a temperature.

Switch off holiday mode:

- Press button – refrigerator compartment until the display  shows the required temperature.



## Alarm

### Door alarm

If the appliance door is open for a while, the door alarm switches on.

- Close the door or press **alarm** button.  
The warning signal is switched off.

## Temperature alarm

If the freezer compartment becomes too warm, the temperature alarm is switched on.

**Caution!**  
**Bacteria may develop during the thawing process and spoil the frozen food**

Do not refreeze thawing or thawed food. Refreeze food only after cooking. Do not store the frozen food for the maximum storage period.

**Note:** The alarm may be actuated without risk to the frozen food in the following cases:

- The appliance is switching on.
- Large quantities of fresh food are put in.
- The freezer compartment door has been open too long.

Indicating warmest temperature and switching off warning signal:

- Press the **alarm** button.  
The display briefly indicates the warmest temperature reached in the freezer compartment. Then the display indicates the set temperature again.

From this time on the warmest temperature is recalculated and saved.

**Note:** The button **alarm** remains lit until the set temperature has been reached again.



## Home Connect

This appliance is Wi-Fi-capable and can be remotely controlled using a mobile device.

**Note:** Wi-Fi is a registered trademark of the Wi-Fi Alliance.

In the following cases, the appliance functions like a refrigerator without a network connection and can still be operated manually using the controls:

- The appliance is not connected to a home network.
- The Home Connect service is not available in the country in which the appliance is set up. For an overview of the countries in which Home Connect is available, see [www.home-connect.com](http://www.home-connect.com).

**Note:** Please observe the safety instructions in this user manual. Ensure that these are also observed if you operate the appliance via the Home Connect app and are not at home when doing so.

→ "Safety instructions" on page 4  
Please also follow the instructions in the Home Connect app.

## Setting up Home Connect

### Notes

- Observe the Home Connect supplementary sheet, which is available for download under [www.siemens-home.bshg-group.com](http://www.siemens-home.bshg-group.com) with the instructions. To do so, enter the E-number of your appliance in the search field.

- After switching on the appliance, wait at least two minutes until internal device initialisation is complete. Only then start setting up Home Connect.
- To implement settings with Home Connect, the Home Connect app must be installed on your mobile device.  
Observe the supplied Home Connect documents for this.  
Follow the steps specified by the app to implement the settings.
- The Home Connect menu will close automatically when the appliance is not operated for a lengthy period of time. You can find information on how to open the Home Connect menu at the start of the appropriate sections.

### Automatic connection with the home network (WLAN)

If a WLAN router with WPS function is available, the refrigerator can automatically connect to the home network.

1. Press the button.  
The refrigerator compartment temperature display shows **Cn**.
2. Press button +/- refrigerator compartment until the refrigerator compartment temperature display shows **AC** and the freezer compartment temperature display shows **OF**.
3. Press button +/- freezer compartment.  
The appliance is ready for the automatic connection.  
Freezer compartment temperature display shows an animation for 2 minutes.  
The appliance is ready for the automatic connection for as long as the animation is displayed.

4. Within those 2 minutes, activate the WPS function on the home network router (e.g. using the WPS/WLAN button; observe information on this topic in the router documentation). If the connection is successful, **On** flashes up in the freezer compartment temperature display. The refrigerator is ready to connect with the app.

**Note:** If the freezer compartment temperature display shows **OF**, no connection could be established.

1. Check whether the refrigerator is located within the range of the home network (WLAN).
2. Repeat the process or establish the connection manually.

### Manual connection with the home network (WLAN)

If the WLAN router present does not have a WPS function, or if this is unknown, you can manually connect the refrigerator with the home network.

1. Press the  button.  
The refrigerator compartment temperature display shows **Cn**.
2. Press button +/- refrigerator compartment until the refrigerator compartment temperature display shows **SA** and the freezer compartment temperature display shows **OF**.
3. Press button +/- freezer compartment.  
The appliance is ready for the manual connection.  
The freezer compartment temperature display shows an animation.  
The appliance is ready for the manual connection for as long as the animation is displayed.

4. The refrigerator has now set up its own WLAN network with the network name HomeConnect.  
You can now access this network with your mobile device.
5. Call up the WLAN settings in the settings menu of the mobile device.
6. Connect the mobile device with the WLAN network HomeConnect.  
Password: HomeConnect  
It can take up to 60 seconds to establish the connection.
7. After successfully connecting, open the Home Connect app on the mobile device.  
The app will search for the refrigerator.
8. As soon as the refrigerator has been found, enter the network name (SSID) and the password (Key) of your own home network (WLAN) into the corresponding fields.
9. Confirm with the button **Transmit to domestic appliances**.
  - If the connection is successful, **On** flashes up in the freezer compartment temperature display.  
You can now connect the refrigerator with the app.
  - If the freezer compartment temperature display shows **OF**, no connection could be established.  
Check whether the refrigerator is located within the range of the home network (WLAN).  
Repeat the process.



## Connecting the refrigerator to the Home Connect app

1. Press  button.  
The refrigerator compartment temperature display shows **Cn**.
  2. Keep pressing **+/-** button refrigerator compartment until the refrigerator compartment temperature display shows **PA** and the freezer compartment temperature display shows **OF**.
  3. Press **+/-** button freezer compartment to connect the appliance to the app.  
The freezer compartment temperature display shows an animation.  
As soon as the refrigerator and the app are connected, the freezer compartment temperature display shows **On**.
  4. Open the app and wait until the refrigerator is displayed.  
Use **Add** to confirm the connection between the app and the refrigerator.  
If the refrigerator is not automatically displayed, click on **Add appliance** in the app and follow the instructions.  
As soon as your refrigerator is displayed, add it with **+**.
  5. Follow the instructions in the app until the process is complete.  
The refrigerator compartment temperature display shows **PA** and the freezer compartment temperature display shows **On**.  
The refrigerator has been connected to the app.  
If the connection fails, check whether the mobile device is connected to the home network (WLAN).  
Then try to establish the connection again.  
If **Er** appears in the freezer compartment temperature display, reset the Home Connect settings.
- Note:** On resetting, all Home Connect settings are reset.

## Verify signal strength

You should verify the signal strength if no connection can be established.

1. Press the  button.  
The refrigerator compartment temperature display shows **Cn**.
2. Press button **+/-** refrigerator compartment until the refrigerator compartment temperature display shows **SI**. In the freezer compartment temperature display a value appears between 0 (no signal) and 3 (full signal).  
The signal strength should be at least 2. If the signal strength is too weak, the connection may be interrupted.
  - Place the router and refrigerator closer together.
  - Ensure that the connection is not interfered with by screening walls.
  - Alternatively, install a repeater to make the signal stronger.

## Resetting Home Connect settings

If there is a problem when trying to establish a connection or if you would like to register the appliance in a different home network (WLAN), the Home Connect settings can be reset:

1. Press the  button.  
The refrigerator compartment temperature display shows **Cn**.
2. Press button **+/-** refrigerator compartment until the refrigerator compartment temperature display shows **rE** and the freezer compartment temperature display shows **OF**.
3. Press button **+/-** freezer compartment.  
Freezer compartment temperature display shows an animation for 15 seconds.  
Then the freezer compartment temperature display shows **OF**.  
The Home Connect settings have been reset.

## Installing updates for the Home Connect software

The refrigerator checks at regular intervals whether updates are available for the Home Connect software.

If an update is available, the refrigerator compartment temperature display shows **UP**.

Pressing any button will reset the display to the set temperature.

Installing the update:

1. Press the  button.  
The refrigerator compartment temperature display shows **Cn**.
2. Press button **+/-** refrigerator compartment until the refrigerator compartment temperature display shows **UP** and the freezer compartment temperature display shows **OF**.
3. Press button **+/-** freezer compartment.  
The freezer compartment temperature display shows an animation.  
The update will be installed.  
During the installation, all buttons are locked.
  - If the installation was successfully completed, the freezer compartment temperature display will show **On**.
  - If the installation was not successfully completed, the freezer compartment temperature display will show **Er**.  
Start the update again at a later time.  
Inform the Customer Service if the installation has still not been successfully completed after several attempts.

## Information on data protection

The first time your Home Connect appliance is registered on the WLAN network connected to the Internet, your appliance will transmit the following types of data to the Home Connect server (initial registration):

- Unique appliance identification (consisting of appliance codes as well as the MAC address of the installed Wi-Fi communication module).
- Security certificate of the Wi-Fi communication module (to ensure a secure data connection).
- The current software and hardware version of your home appliance.
- Status of any previous resetting to factory settings.

This initial registration prepares the Home Connect functions for use and is only required when you want to use these Home Connect functions for the first time.

**Note:** Please note that the Home Connect functions can only be utilised with the Home Connect app. Information on data protection can be called up in the Home Connect app.

## Declaration of Conformity

BSH Hausgeräte GmbH hereby declares that the appliance with Home Connect functionality meets the essential requirements and the other relevant provisions of the Directive 2014/53/EU.

A detailed RED Declaration of Conformity can be found online at [www.siemens-home.bshg-group.com](http://www.siemens-home.bshg-group.com) among the additional documents on the product page for your appliance.



2.4 GHz band: 100 mW max.  
5 GHz band: 100 mW max.

	BE	BG	CZ	DK	DE	EE	IE	EL
	ES	FR	HR	IT	CY	LV	LT	LU
	HU	MT	NL	AT	PL	PT	RO	SI
	SK	FI	SE	UK	NO	CH	TR	

5 GHz WLAN: for indoor use only

## Refrigerator compartment

The refrigerator compartment is suitable for storing dairy products, eggs, cooked meals, pastries, preserves once opened and hard cheese.

The temperature can be set from +3 °C ... +8 °C.

The refrigerator compartment can also be used to store highly perishable foods in the short to medium term. The lower the selected temperature, the slower the enzymatic and chemical processes and deterioration by microorganisms. A temperature of +4 °C or lower ensures optimum freshness and safety of the stored foods.

### Note when storing food

- Store fresh, undamaged food. The quality and freshness will then be retained for longer.
- In the case of ready products and bottled goods do not exceed the minimum sell-by date or use-by-date indicated by the manufacturer.

- To retain aroma, colour and freshness, pack or cover food well before placing it in the appliance. This avoids transference of flavours and discolouration of the plastic parts.
- Leave warm food and drinks to cool down before placing them in the refrigerator compartment.

### Note the chill zones in the refrigerator compartment

The air circulation in the refrigerator compartment creates different chill zones.

#### Coldest zone

The coldest zone is on the partition and in the storage area for large bottles.

#### Warmest zone

The warmest zone is at the very top of the door.

#### Notes

- Store e.g. hard cheese and butter in the warmest zone. Cheese can then continue to release its aroma and the butter will still be easy to spread.
- Store perishable food such as fish, sausages and meat in the cool-fresh compartment. → *"Cool-fresh compartment" on page 20*



## Cool-fresh compartment

The temperature in the cool-fresh compartment is kept at around 0 °C.

The low temperature and the optimum moisture provide ideal storage conditions for fresh food.

With cool-fresh storage, you can keep fresh foodstuffs fresh for up to three times longer than in the refrigerator compartment – for even longer freshness, nutrient retention and better flavour.

### Vegetable container

→ Fig. 10

The vegetable container is the best storage location for fresh fruit and vegetables. You can adjust the humidity in the vegetable container via the humidity controller of the division plate and a special seal.

The humidity in the vegetable container can be set according to the type and amount of products to be stored:

- Mainly fruit as well as for a large load – set lower air humidity
- Mainly vegetables as well as for a mixed or small load – set higher air humidity

### Notes

- Fruit sensitive to cold (e.g. pineapple, banana, papaya and citrus fruit) and vegetables sensitive to cold (e.g. aubergines, cucumbers, courgettes, peppers, tomatoes and potatoes) should be stored outside the appliance at temperatures of approx. +8 °C ... +12 °C for optimum preservation of quality and flavour.
- Condensation may form in the vegetable container depending on the food and quantity stored. Remove condensation with a dry cloth and adjust the humidity in the vegetable container with the humidity controller.

### Cool-fresh container

→ Fig. 1/14

The storage climate in the cool-fresh container offers ideal conditions for the storage of fish, meat and sausage.

### Storage times at 0 °C

The storage times are dependent on the original quality.

Fresh fish, seafood:	up to 3 days
Poultry, meat (boiled/fried):	up to 5 days
Beef, pork, lamb, sausage products (cold meat):	up to 7 days
Smoked fish, broccoli:	up to 14 days
Salad greens, fennel, apricots, plums:	up to 21 days
Soft cheese, yoghurt, quark, buttermilk, cauliflower:	up to 30 days



## Freezer compartment

The freezer compartment is suitable for:

- Storing frozen food
- Making ice cubes
- Freezing food

The temperature can be set from  $-16\text{ }^{\circ}\text{C}$  ...  $-24\text{ }^{\circ}\text{C}$ .

The freezer compartment can be used to store perishable foods long-term almost without any noticeable reduction in quality, as the low temperatures considerably slow down or stop deterioration. Appearance, flavour and all valuable ingredients are largely retained.

Long-term storage of food should be at  $-18\text{ }^{\circ}\text{C}$  or lower.

The time between putting fresh food in the freezer compartment and it freezing solid depends on the following factors:

- set temperature
- type of food
- amount of food in the freezer compartment
- quantity and type of storage

### Freezing small amounts of food

Freezing food:

- in the freezer tray positioned at the rear on the large freezer container or in the flat freezer container  
→ *"Getting to know your appliance" on page 10*
- starting from the outer right
- over a wide area

Food will freeze most quickly this way.

## Maximum freezing capacity

The maximum freezing capacity indicates the quantity of food that can be frozen right through to the centre within 24 hours.

Information about the maximum freezing capacity can be found on the rating plate.

→ *"Getting to know your appliance" on page 10*

To use the maximum freezing capacity, switch on super freezing 24 hours before placing the fresh food in the freezer compartment.

→ *"Super freezing" on page 13*

### Prerequisites for max. freezing capacity

1. Approx. 24 hours before inserting fresh produce: switch on super freezing.  
→ *"Manual super freezing" on page 13*
2. Take the container out of the freezer compartment and stack the food directly on the shelves and on the floor of the freezer compartment.
3. Fill the upper compartment with food first. This is where the food will freeze most quickly.
4. If the top compartment is inadequate, store the remaining quantity in the compartment underneath starting at the front right side.
5. Freeze fresh food as close as possible to the side panels.

## Fully utilising the freezer volume

To place the maximum quantity of frozen food in the freezer compartment:

- Remove all fittings.
- Store food directly on the shelves and on the floor of the freezer compartment.

## Purchasing frozen food

- Check the packaging is not damaged.
- Check there is a sell-by date.
- The temperature in the supermarket freezer must be  $-18^{\circ}\text{C}$  or lower.
- Do not interrupt the freezing chain. If possible, transport frozen food in a cool bag and place in the freezer compartment quickly.

## When loading products, please note:

- Freeze large quantities of food in the top compartment.  
Food will freeze very quickly and gently here.
- Distribute food across the compartments or frozen food containers, leaving plenty of space.
- Do not bring food to be frozen into contact with food already frozen. If required, restack frozen food in the frozen food containers.
- Important for unrestricted air circulation in appliance:  
Push in frozen food containers as far as they will go.

## Freezing fresh food

Freeze only fresh and undamaged food.

Food which is boiled, fried or baked is more suitable for freezing than food which is raw.

Before freezing food, make preparations appropriate to the food in order to retain the best possible nutritional value, flavour and colour:

- Vegetables: wash, chop, blanch.
- Fruit: wash, pit and perhaps peel, possibly add sugar or ascorbic acid solution.

Information on how to do this can be found in the relevant literature.

## Suitable for freezing

- Baked goods
- Fish and seafood
- Meat
- Poultry and game
- Vegetables, fruit and herbs
- Eggs without shells
- Dairy products, e.g. cheese, butter and quark
- Ready meals and leftovers, e.g. soups, stews, cooked meat and fish, potato dishes, bakes and desserts

## Not suitable for freezing

- Types of vegetables which are usually eaten raw, e.g. lettuce or radishes
- Unpeeled or hard boiled eggs
- Grapes
- Whole apples, pears and peaches
- Yoghurt, soured milk, sour cream, creme fraiche and mayonnaise

## Packing frozen food

The correct type of packaging and material selection are decisive factors in the retention of the product quality, and prevent the development of freezer burn.

1. Place food in packaging.
2. Squeeze out the air.
3. Pack food airtight to prevent it from losing flavour and drying out.
4. Label packaging with contents and date of freezing.

Suitable packaging:

- Plastic film
- Tubular film made of polyethylene (PE)
- Aluminium foil
- Freezer containers

Suitable sealing materials:

- Rubber bands
- Plastic clips
- Cold-resistant adhesive tape

Unsuitable packaging:

- Wrapping paper
- Greaseproof paper
- Cellophane
- Rubbish bags and used shopping bags

## Shelf life of frozen food at $-18^{\circ}\text{C}$

Fish, sausage, ready meals, baked goods:	Up to 6 months
Meat, poultry:	Up to 8 months
Fruit, vegetables:	Up to 12 months

## Freezer calendar

The imprinted freezer calendar indicates the maximum storage duration in months at a constant temperature of  $-18^{\circ}\text{C}$ .

## Defrosting frozen food

The defrosting method must be adjusted to the food and application in order to retain the best possible product quality.

Defrosting methods:

- In the refrigerator compartment (especially suitable for animal-based foods such as fish, meat, cheese, quark)
- At room temperature (bread)
- In the microwave (food for immediate consumption or immediate preparation)
- In the oven/cooker (food for immediate consumption or immediate preparation)

### Caution!

Do not refreeze food after it has been defrosted or started to defrost. You can only refreeze the food after it has been used for a ready-to-eat meal (boiled or fried).

The frozen food can no longer be stored for the maximum duration.



## Defrosting

### Refrigerator compartment

The defrost process is performed automatically.

### Freezer compartment

The fully automatic NoFrost system ensures that the freezer compartment remains free of ice. Defrosting is no longer required.



## Cleaning

### Caution!

#### Avoid damaging the appliance and the fittings.

- Do not use abrasive, chloride or acidic cleaning agents or solvents.
- Do not use scouring or abrasive sponges.  
Metallic surfaces may corrode.
- Never clean shelves or containers in the dishwasher.  
These parts may become deformed.

Proceed as follows:

1. Switch off the appliance.
2. Pull out the mains plug or switch off the fuse.
3. Take out the food and store in a cool location.  
If present: place ice pack on the food.
4. If present: wait until the layer of frost has thawed.
5. Clean the appliance with a soft cloth, lukewarm water and a little pH-neutral washing-up liquid.

### Caution!

The rinsing water must not run into the light or through the drainage hole into the evaporation area.

6. Wipe door seal with clear water and dry thoroughly with a cloth.
7. Reconnect and switch on appliance and put in food.

## Cleaning the equipment

To clean, take the variable parts out of the appliance.

→ "Features" on page 11

## Partition and vegetable container cover

### Taking out the partition

→ Fig. 11

- Remove glass plate, press levers on the underside on both sides, pull partition forwards, lift and swivel out to the side.

### Taking out the vegetable container cover

- Lift cover, pull forwards and swivel out to the side.

### Inserting vegetable container cover and partition

→ Fig. 12

1. Insert vegetable container cover.
2. Insert partition.
3. Insert glass plate.

## Telescopic rails

→ Fig. 13

### Removing telescopic rails

1. Pull out telescopic rail.
2. Push lock in the direction of the arrow.
3. Detach telescopic rail from the rear pin.
4. Push telescopic rail together, push backwards above the rear pin and disengage.

### Installing telescopic rails

1. Place the extended telescopic rail on the front pin.
2. Pull the telescopic rail forwards slightly until it engages.
3. Insert telescopic rail on the rear pin.
4. Push lock backwards.



## Odours

If you experience unpleasant odours:

1. Switch off the appliance with the On/Off button ①.
2. Take all food out of the appliance.
3. Clean the inside. → "Cleaning" on page 24
4. Clean all packages.
5. Seal strong smelling food in order to avoid odours from forming.
6. Switch the appliance on again.
7. Store food in the appliance.
8. Check whether the formation of odours is still occurring after 24 hours.

## Lighting

Your appliance features a maintenance-free LED light.

Only Customer Service or authorised technicians may repair the light.

## Noises

### Normal noises

**Note:** When automatic or manual super freezing is switched on, increased operating noises may occur.

**Droning:** A motor is running, e.g. refrigerating unit, fan.

**Bubbling, buzzing or gurgling:** Refrigerant is flowing through the tubes.

**Clicking:** The motor, switches or solenoid valves are switching on and off.

**Cracking:** Automatic defrosting is running.

### Preventing noises

**Appliance is not level:** Align appliance using a spirit level. If required, place a little packing underneath.

**Containers, shelves or storage compartments wobble or stick:** Check the removable fittings and re-insert if required.

**Bottles or receptacles are touching each other:** Move bottles or receptacles away from each other.



## What to do in the event of a fault

Before you call Customer Service, use this table to check whether you can rectify the fault yourself.

### Temperature differs greatly from the set value.

Switch off appliance for 5 minutes.  
→ "Switching off and disconnecting the appliance" on page 12  
If the temperature is too warm, check temperature again after a couple of hours.  
If the temperature is too cold, check temperature again on the following day.

### Displays do not illuminate.

The mains plug has not been inserted properly.	Connect mains plug.
The fuse has been tripped.	Check the fuses.
The power has failed.	Check whether the power is on.

### Display shows E....

Electronics have detected a fault.	Call Customer Service. → "Customer Service" on page 28
------------------------------------	---

### A warning signal sounds and the alarm button is lit.

	Press the <b>alarm</b> button. Alarm is switched off.
Appliance door is open.	Close the appliance door.
Ventilation openings have been covered.	Clear ventilation openings.
Large quantities of fresh food were placed in the appliance.	Do not exceed max. freezing capacity.

### Display flashes, warning signal sounds and button alarm is lit.

	Press the <b>alarm</b> button. Alarm is switched off.
Appliance door is open.	Close the appliance door.
Ventilation openings have been covered.	Clear ventilation openings.
Large quantities of fresh food were placed in the appliance.	Do not exceed max. freezing capacity.

### Display flashes.

The temperature in the freezer compartment was too warm.

When button **alarm** has been pressed, the warmest temperature reached in the freezer compartment is displayed for 5 seconds. Press the **alarm** button. The display stops flashing.

### Appliance is not cooling, display and lighting are lit.

Showroom mode switched on.

Start the appliance self-test.

→ *"Appliance self-test" on page 28*

When the programme has ended, the appliance switches over to normal operation.

### Automatic super freezing does not switch on.

The appliance decides independently whether automatic super freezing is required and switches it on or off automatically.

### It is too warm or too cold in the cool-fresh compartment.

The standard setting has been set too high or low (e.g. frost in the cool-fresh compartment).

You can set the temperature in the cool-fresh compartment to be 3 settings warmer or colder. If the temperature in the refrigerator compartment is set to setting 0, the cool-fresh compartment has a temperature of around 0 °C.

1. Press and hold the refrigerator compartment **super** button until the display temperature refrigerator compartment flashes.
2. Press **+/-** button to change the setting. Setting -3 corresponds to the coldest setting. Setting +3 corresponds to the warmest setting. The selected setting is saved after one minute.

## Customer Service

If you are unable to rectify the fault, please contact our Customer Service. We will always find a suitable solution to avoid unnecessary visits by technicians.

The contact information for your nearest Customer Service office can be found here or on the enclosed Customer Service list.

When calling, please state the product number (E-Nr.) and the production number (FD), which can be found on the rating plate.

→ *"Getting to know your appliance" on page 10*

**You can trust in the manufacturer's expertise.** You can therefore be sure that the repair is carried out by trained service technicians who carry original spare parts for your home appliances.

## Appliance self-test

Your appliance features a self-test programme; this displays the fault which your Customer Service team can rectify.

1. Switch off the appliance and wait 5 minutes.
  2. Switch on the appliance.
  3. Within the first 10 seconds, press and hold the freezer compartment **super** button for 3 ... 5 seconds until an audible signal sounds. The self-test programme starts. While the self-test is running, a long audible signal sounds in the meantime.
- If 2 audible signals sound after the end of the self-test and the set temperature is displayed, your appliance is OK.

- If, at the end of the self-test, 5 audible signals sound and the freezer compartment **super** button flashes for 10 seconds, inform customer service.

When the programme has ended, the appliance switches over to normal operation.

## Obtaining advice and ordering repairs if a fault occurs

Contact information for all countries can be found on the enclosed Customer Service list.

GB	0344 892 8999	Calls charged at local or mobile rate.
IE	01450 2655	€0.03 per minute at peak. Off peak: €0.0088 per minute.
US	866 447 4363	Toll-free

## Guarantee

Detailed information on the warranty period and warranty conditions in your country are available from your customer service, your dealer and on our website.









---

---

---

---

---

---

---

---

---

---

---

---

---

---

---

---

---

---

---

---

---







\_\_\_\_\_

\_\_\_\_\_

\_\_\_\_\_

\_\_\_\_\_

\_\_\_\_\_

\_\_\_\_\_

\_\_\_\_\_

\_\_\_\_\_

\_\_\_\_\_

\_\_\_\_\_

\_\_\_\_\_

\_\_\_\_\_

\_\_\_\_\_

\_\_\_\_\_

\_\_\_\_\_

\_\_\_\_\_

\_\_\_\_\_

\_\_\_\_\_

\_\_\_\_\_

\_\_\_\_\_

\_\_\_\_\_

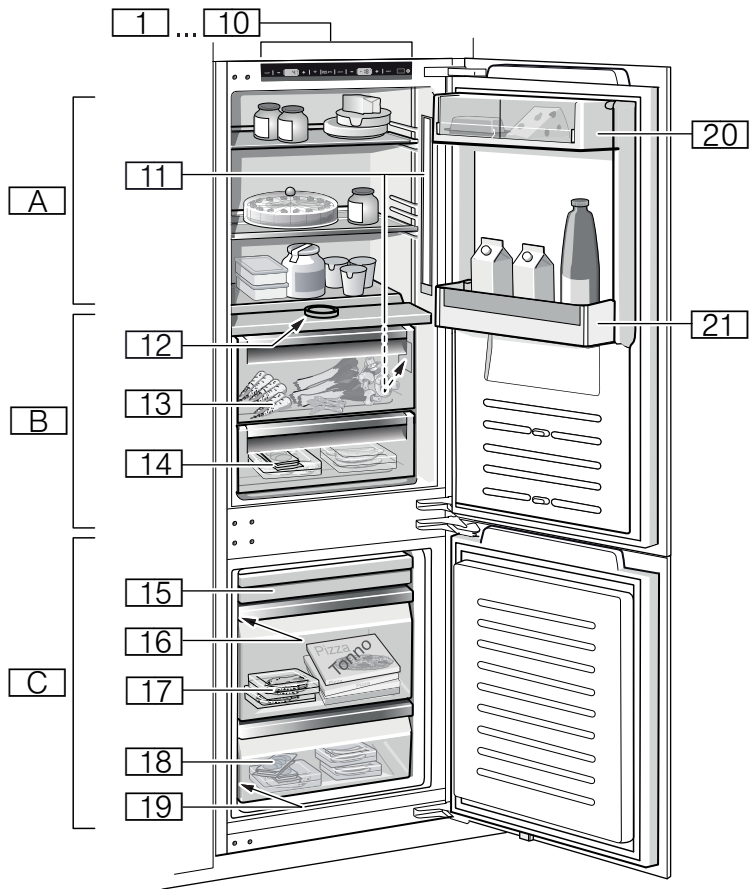

**1**

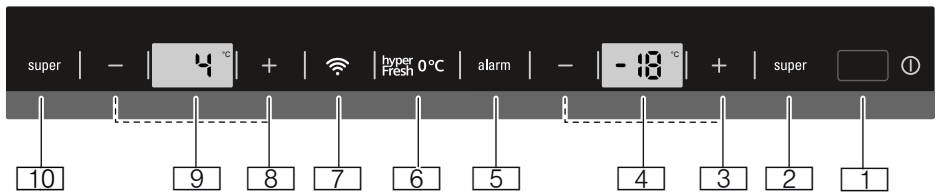

**2**



3



4

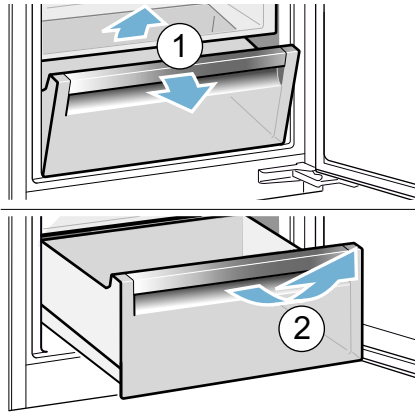

5

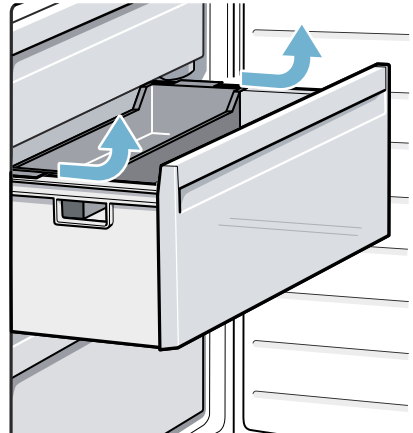

6



7

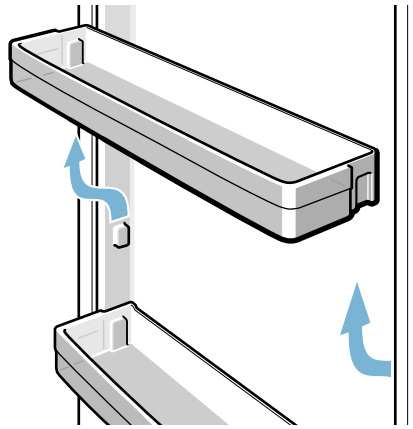

8

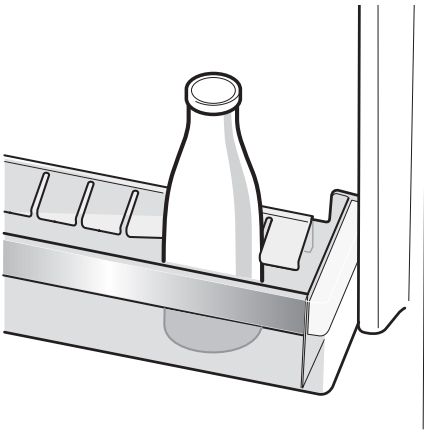

9

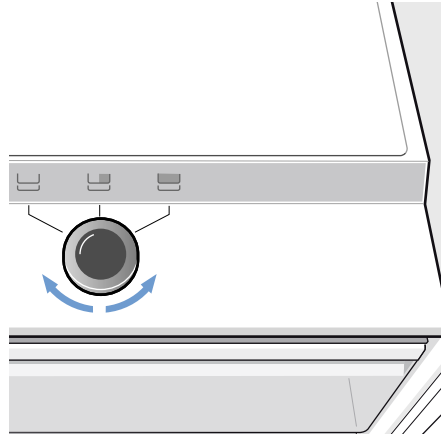

10

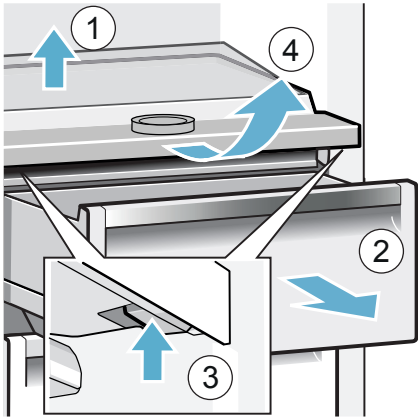

11

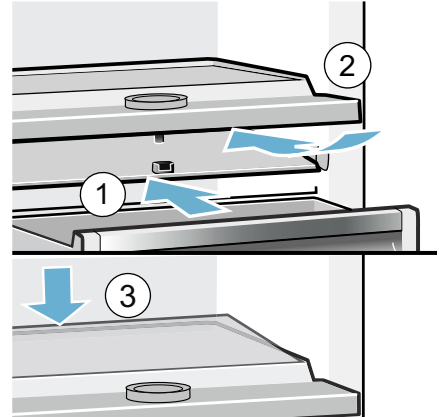

12

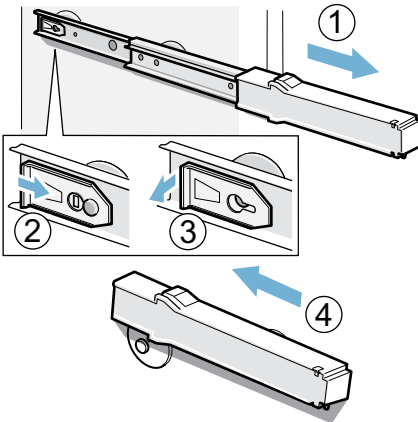

13

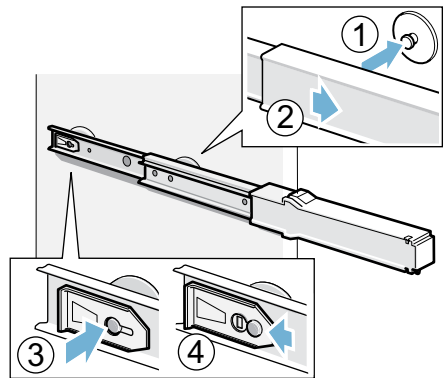

BSH Hausgeräte GmbH  
Carl-Wery-Straße 34,  
81739 München, GERMANY

[siemens-home.bsh-group.com](https://siemens-home.bsh-group.com)

Manufactured by BSH Hausgeräte GmbH under Trademark License of Siemens AG



**8001121463 (9811)**  
en