



Register your new Bosch now:
www.bosch-home.com/welcome



BGL4...



en Instruction manual

zh 使用說明

Safety information	4
Your vacuum cleaner	6
Replacement parts and special accessories	7
Before using your appliance for the first time	8
Initial use	8
Vacuuming	10
When the work is done	12
Changing the filter	12
Replacing the exhaust filter	15
Care	16
Customer service	17
Disposal information	18
Conditions of guarantee	19

安全信息20
您的吸塵機21
更換零件和特殊配件22
首次使用電器前23
初次使用23
吸塵25
使用後27
更換濾網27
更換排氣濾網30
護理31
客戶服務32
棄置資訊33

Safety information

Congratulations on your purchase of the Bosch GL40 vacuum cleaner.

This instruction manual describes various GL40 models, which means that some of the equipment features and functions described may not apply to your model. You should only use original Bosch accessories, which have been specially developed for your vacuum cleaner, in order to achieve the best possible vacuuming results.

Please keep this instruction manual. When passing the vacuum cleaner on to another person, please also hand over this instruction manual.

Intended use

This appliance is intended for domestic use only. This appliance is intended for use up to a maximum height of 2000 metres above sea level. Only use this vacuum cleaner in accordance with the instructions in this instruction manual.

Therefore, please note the following points!

The vacuum cleaner must only be operated with:

- Original replacement parts, accessories or special accessories
- In order to avoid invalidating the warranty, we recommend that you operate your appliance using only original dust bags.

In order to prevent injuries and damage, the vacuum cleaner must not be used for:

- Vacuum-cleaning persons or animals
- Vacuuming up:
 - insects or spiders.
 - hazardous, sharp-edged, hot or glowing substances.
 - damp or liquid substances.
 - highly flammable or explosive substances and gases.
 - ash, soot from tiled stoves and central heating systems.
 - toner dust from printers and copiers.

Safety information

This vacuum cleaner complies with the recognised rules of technology and the relevant safety regulations.

- The appliance may be used by children over the age of 8 years and by persons with reduced physical, sensory or mental capacity or by persons with a lack of experience or knowledge if they are supervised or have been instructed on the safe use of the appliance and the have understood the potential dangers of using the appliance.

- Children must never play with the appliance.
- Cleaning and user maintenance must never be carried out by children without supervision.
- Plastic bags and films must be kept out of the reach of children before disposal.
=> Risk of suffocation.

Proper use

- Only connect and use the vacuum cleaner in accordance with the specifications on the rating plate.
- Never vacuum without the dust bag or dust container, motor protection or exhaust filter.
=> This may damage the vacuum cleaner.
- Always keep the vacuum cleaner away from your head when using nozzles and tubes.
=> This could cause injury!
- When vacuuming stairs, the appliance must always be positioned below the user.
- Do not use the power cord or the hose to carry or transport the vacuum cleaner.
- For safety reasons, if this appliance's mains power cable becomes damaged, it must be replaced by the manufacturer, their after-sales service department or a similarly qualified person.
- If using the appliance for longer than 30 minutes, pull out the power cord completely.
- When disconnecting the appliance from the mains, pull on the plug itself to remove it; do not pull on the power cord.
- Do not pull the power cord over sharp edges or allow it to become trapped.
- When the cable is being automatically rewound, ensure that the mains plug is not thrown towards persons, body parts, animals or objects.
=> Use the mains plug to guide the power cord.
- Pull out the mains plug before carrying out any work on the vacuum cleaner.
- Do not operate the vacuum cleaner if it is damaged. Unplug the appliance from the mains if a fault is detected.
- For safety reasons, only authorised after-sales service personnel are permitted to carry out repairs and fit replacement parts to the vacuum cleaner.
- Protect the vacuum cleaner from the weather, moisture and sources of heat.
- Do not pour flammable substances or substances containing alcohol onto the filters (dust bag, motor protection filter, exhaust filter, etc.).
- The vacuum cleaner is not suitable for use on construction sites.
=> Vacuuming up building rubble could damage the appliance.
- When not in use, switch off the appliance and pull out the mains plug.
- At the end of its life, the appliance should immediately be rendered unusable, then disposed of in an appropriate manner.

! Please note

The mains socket must be protected by at least a 16 amp circuit breaker.

If a circuit breaker is tripped when you switch on the vacuum cleaner, this may be because other electrical appliances which have a high current draw are connected to the same power circuit.

To prevent the circuit breaker from tripping, select the lowest power setting before switching the appliance on, and increase the power only once it is running.

Notes on the energy label

This vacuum cleaner is a general purpose vacuum cleaner with a primary hose.

To achieve the declared energy efficiency and cleaning performance class on carpet, please use the interchangeable universal nozzle.

To achieve the declared energy efficiency and cleaning performance class on hard floor with nooks and crannies, please use the hard floor nozzle provided.

These calculations are based on the Commission Delegated Regulation (EU) No. 665/2013 of 3rd May 2013 supplementing Directive 2010/30/EU.

Unless otherwise stated, all the procedures referred to in these instructions were carried out in accordance with the EN 60312-1:2017* standard.

*As the motor service test is carried out with the dust collector empty, the stated motor service life must be increased by 10% for tests with the dust collector half filled.

Your vacuum cleaner

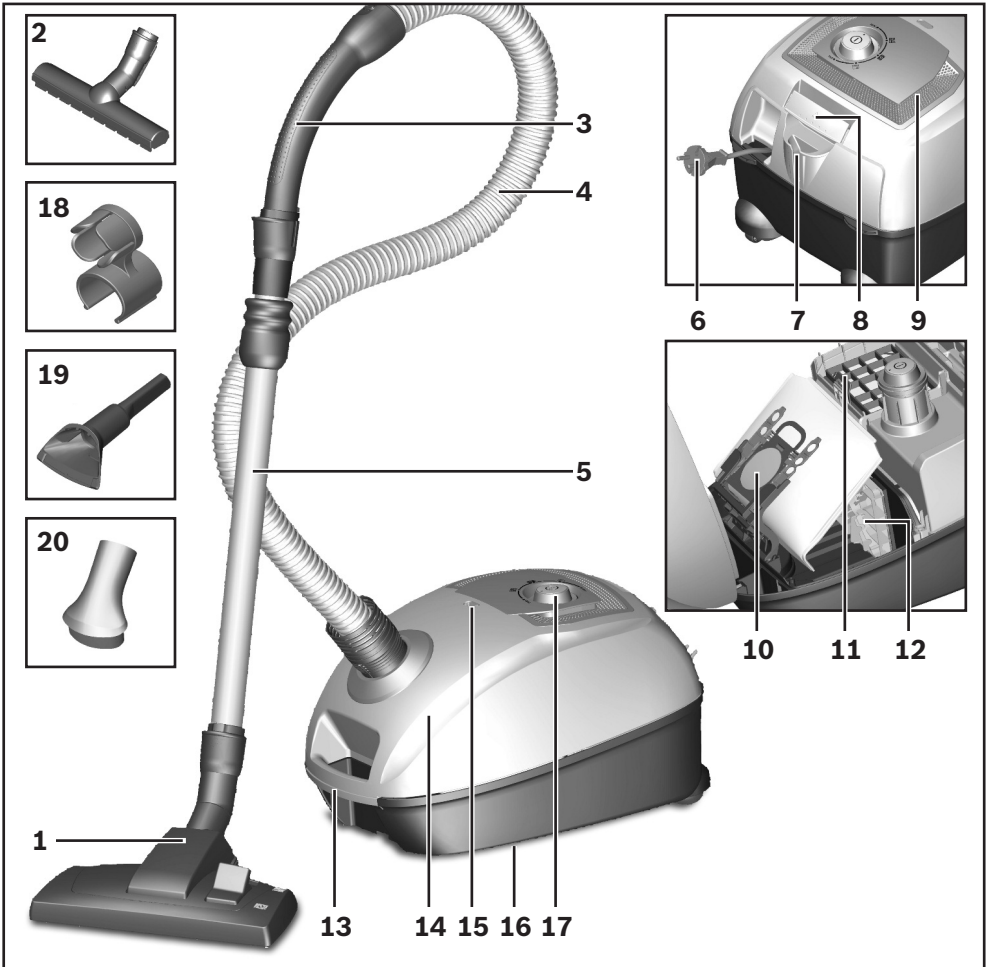

- | | |
|--|---|
| 1 Adjustable floor tool (with locking collar) | 11 Exhaust filter* |
| 2 Hard-floor brush (with locking collar) | 12 Motor protection filter, washable |
| 3 Hose hand grip | 13 Carrying handle |
| 4 Flexible hose | 14 Dust bag compartment lid |
| 5 Telescopic tube with adjusting sleeve (and locking collar) | 15 Dust bag change indicator |
| 6 Power cord | 16 Storage aid (on underside of appliance) |
| 7 Parking aid | 17 On/off button and power controller |
| 8 Locking lever | 18 Accessories holder for multi-purpose nozzle* |
| 9 Exhaust grille | 19 Multi-purpose nozzle |
| 10 Dust bag | 20 Hard furnishing brush |

Replacement parts and special accessories

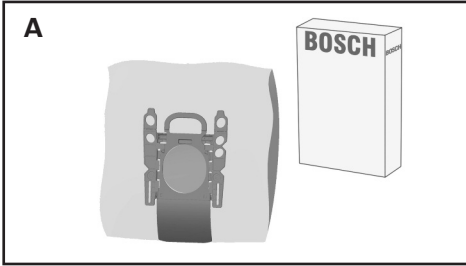

A Dust bag

To get the most out of your appliance, we recommend using PowerProtect genuine replacement bags (BBZ41FGALL).

Contents:

- 4 dust bags with fasteners
- 1 micro-hygiene filter

PLEASE NOTE

- Your appliance is a highly efficient vacuum cleaner that can only achieve its best cleaning results using genuine dust bags.

Only if high-quality dust bags are used, such as genuine Bosch dust bags, can the figures specified on the EU energy label pertaining to energy efficiency class, suction and dust retention capacity be achieved.

Additionally, using inferior quality dust bags (e.g. paper bags) can have a significant impact on the service life and performance of your appliance.

Warranty claims can only be made if genuine Bosch dust bags are used.

For more information and to order genuine Bosch dust bags, go to

www.bosch-home.com/dust-bag

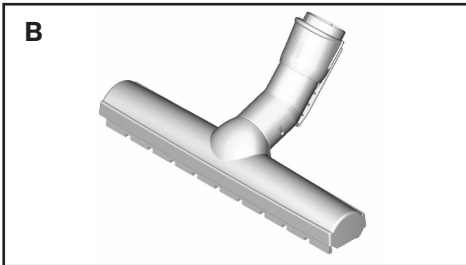

B Hard floor brush BBZ123HD

For vacuuming hard floors
(parquet, tiles, terracotta, etc.)

Before using your appliance for the first time

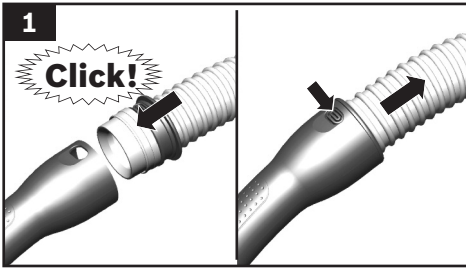

Figure 1

- Push the hand grip onto the flexible hose and lock it in place.
- To remove the hand grip, press the two catches together and pull out the flexible hose.

Initial use

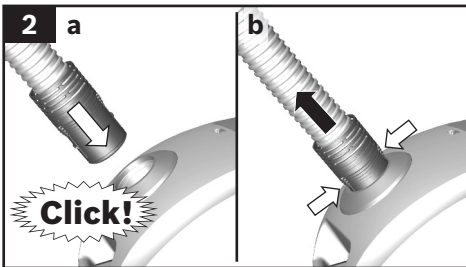

Figure 2

- a) Push the flexible hose adapter into the air intake opening in the vacuum cleaner lid until it locks in place.
- b) To remove the flexible hose, press the two catches together and pull out the hose.

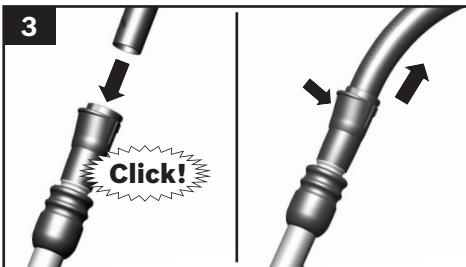

Figure 3

- Push the hand grip into the telescopic tube until it engages. To release the connection, squeeze the collar sleeve and pull the handle out.

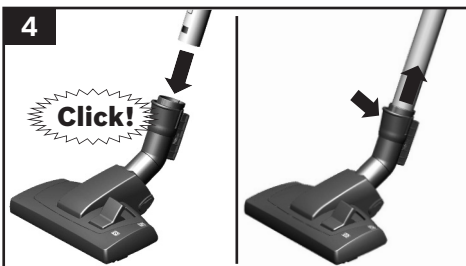

Figure 4

- Push the telescopic tube into the connecting piece of the floor tool until it locks in place. To release the connection, press on the locking collar and pull out the telescopic tube.

Initial use

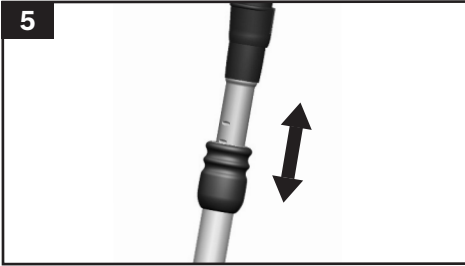

Figure 5

- Move the adjusting sleeve/slider button in the direction of the arrow to unlock the telescopic tube and adjust it to the length required.

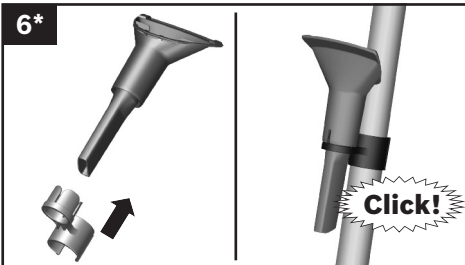

Figure 6*

- Attach the accessories holder to the multi-purpose nozzle and clip it onto the suction pipe/telescopic tube.

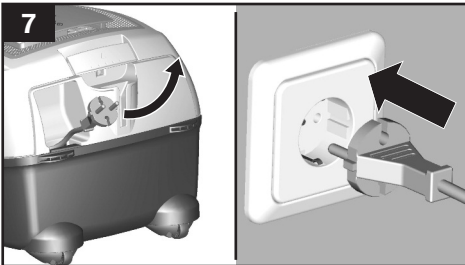

Figure 7

- Holding the power cord by the plug, pull out to the required length and insert the plug into the mains socket.

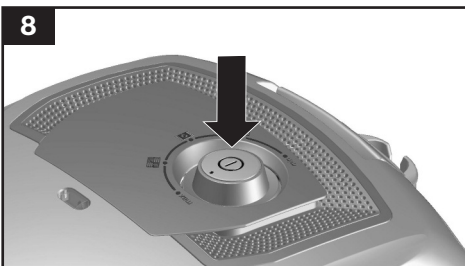

Figure 8 **Switching on and off**



- Press the ON/OFF button in the direction of the arrow to switch your vacuum cleaner on.

Initial use



Figure 9 Controlling the suction level

The suction level can be infinitely adjusted to the level required by turning the control knob in the direction of the arrow.

- Low power range
For vacuuming delicate materials, e.g. upholstery, curtains, etc. => 
- Medium power range
For the daily vacuuming of light dirt deposits. => 
- High power range
For vacuuming durable floor coverings, hard floors and heavily soiled surfaces. => 

Vacuuming

Caution:

- Floor tools are subject to a certain amount of wear, depending on the type of hard floor you have (e.g. rough, rustic tiles). Therefore, you must check the underside of the floor tool at regular intervals. Worn undersides of floor tools may have sharp edges that can damage sensitive hard floors, such as parquet or linoleum. The manufacturer does not accept any responsibility for damage caused by worn floor tools.

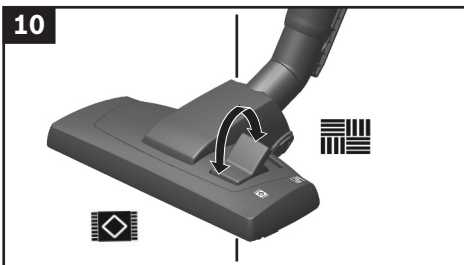

Figure 10

Set the adjustable floor nozzle:

- Rugs and carpets => 
- Hard floors => 

If you are vacuuming up relatively large particles, make sure that you vacuum them up successively and carefully to ensure that the vacuum channel of the floor tool does not become blocked. If necessary, you should raise the nozzle in order to better vacuum up the dirt particles.

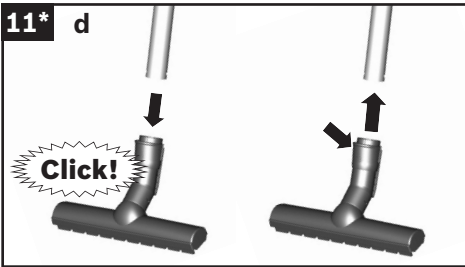
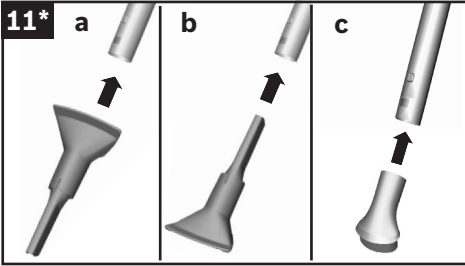

Figure 11* Vacuuming with accessories

Attach the nozzles to the suction pipe or hand grip as required:

- a) Crevice nozzle for vacuuming crevices and corners, etc.
- b) Upholstery nozzle for vacuuming upholstered furniture, curtains, etc.
- c) Hard furnishing brush

d) Hard-floor tool

For vacuuming hard floor coverings (tiles, parquet flooring, etc.)

- Push the telescopic tube into the connecting piece of the hard floor tool until it locks in place.
- To release the connection, press the locking collar and pull out the telescopic tube.

Turbo brush

If your appliance is equipped with a turbo brush, consult the accompanying instruction manual for instructions on its use and maintenance.

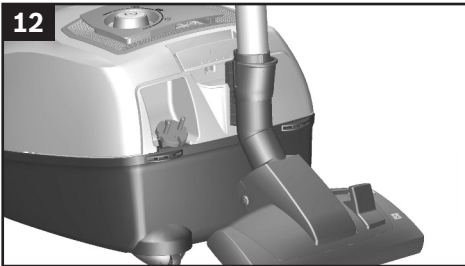

Figure 12

You can use the parking aid on the back of the vacuum cleaner if you wish to stop vacuuming for a short time.

- Once you have switched off the appliance, slide the hook on the floor tool into the recess on the rear of the appliance.

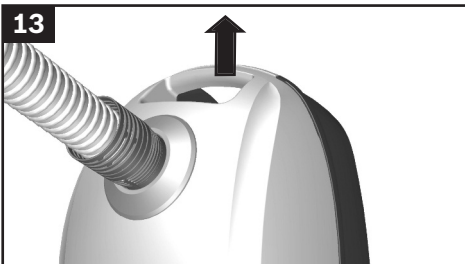

Figure 13

To overcome obstacles, e.g. steps, the appliance can also be carried by the handle on the appliance body.

When the work is done

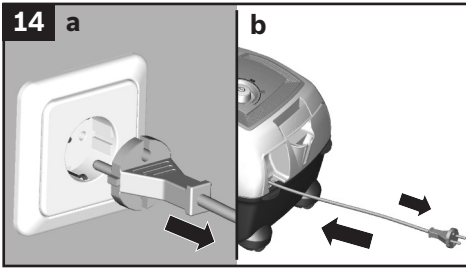

Figure 14

- a) Pull out the mains plug.
- b) Briefly pull on the power cord and then release it (the power cord retracts automatically).

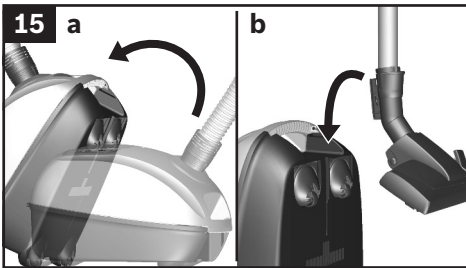

Figure 15

To store/transport the appliance, you can use the storage aid on the underside of the appliance.

- a) Stand the appliance upright on its end.
- b) Slide the hook on the floor tool into the recess on the underside of the appliance.

Changing the filter

- ! **Caution: Always switch off the appliance before changing the filter.**

Replacing the dust bag

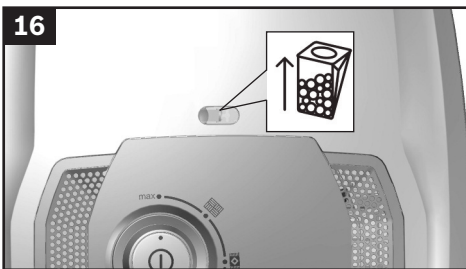

Figure 16

- If the dust bag change indicator in the lid is filled completely when the floor tool is lifted from the floor with the highest suction level selected, the dust bag must be changed, even though it may not yet be full. Even if the dust bag is not full, it may still need changing, due to the type of dust which has been vacuumed. First check that the nozzle, suction pipe and flexible hose are not blocked, as this would also lead to the dust bag change indicator being triggered.
- The hand grip can easily be detached from the hose to remove blockages.

Changing the filter

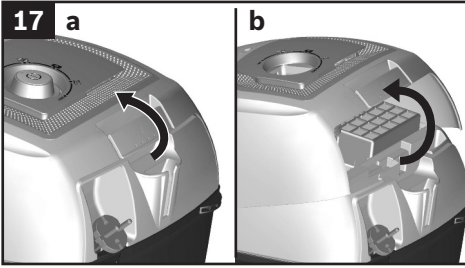

Figure 17 Opening the lid

- a) Unlock the lid by pulling on the locking lever in the direction of the arrow.
- b) Open the lid in the direction of the arrow.

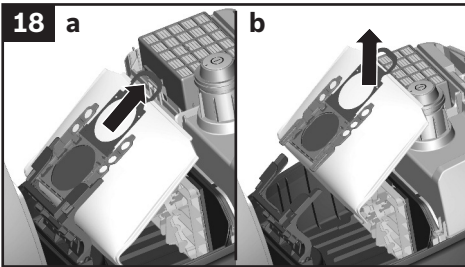
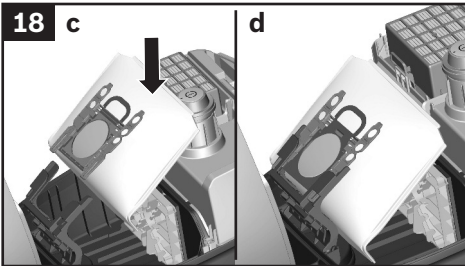

Figure 18

- a) Close the dust bag by pulling on the locking tab.
- b) Take out the dust bag.



- c) Insert a new dust bag.
- d) Push the dust bag fully into the holder.

! Please note: the lid will only close if a dust bag has been inserted.

Changing the filter

Cleaning the motor protection filter

The motor protection filter should be cleaned regularly by knocking out the dirt and rinsing.

Figure 19

Open the dust bag compartment lid. **Figure 17**

a) Release the motor protection filter from the catch by pulling it sideways, and pull it out in the direction of the arrow.

b) Clean the motor protection filter by tapping out the dirt.

c) If it is very dirty, the motor protection filter should be rinsed.

- The filter must then be left to dry for at least 24 hours.

d) After cleaning, refit the motor protection filter into the appliance, lock it in place and close the dust bag compartment lid.

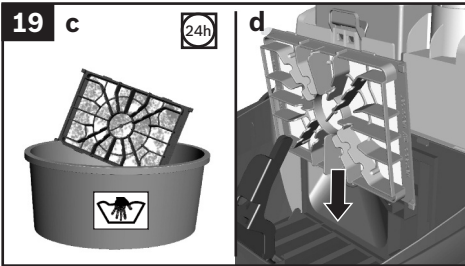
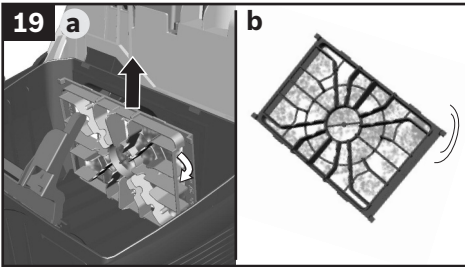

Replacing the exhaust filter

Vacuum cleaner with micro-hygiene filter

This should be replaced with every replacement filter pack.

Figure 20*

Open the dust bag compartment lid. **Figure 17**

a) Release the filter holder by moving the locking lever in the direction of the arrow.

b) Remove the micro-hygiene filter.

c) The micro-hygiene filter can be rinsed out.

- The filter must then be left to dry for at least 24 hours.

d) Remove the micro-hygiene filter. Insert the new micro-hygiene filter into the appliance.

e) Insert the filter holder into the appliance and lock it in place.

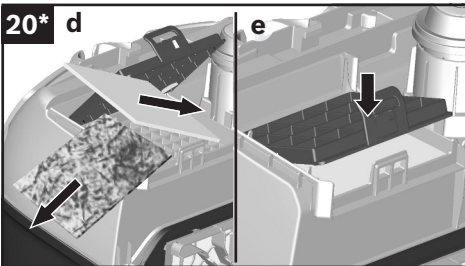
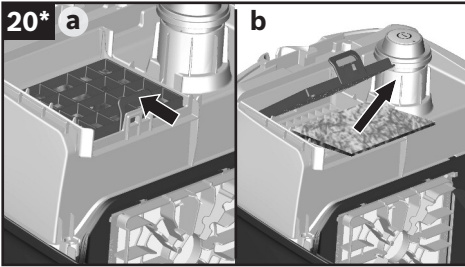

Replacing the exhaust filter

Vacuum cleaner with HEPA filter

If your vacuum cleaner is equipped with a HEPA filter, this must be replaced once a year.

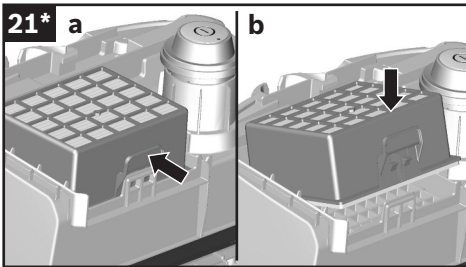

Figure 21*

Open the dust bag compartment lid. **Figure 17**

- a) Unlock the HEPA filter by moving the locking lever in the direction of the arrow and remove the filter from the appliance.
- b) Insert the new HEPA filter and lock it in place.

After vacuuming fine dust particles, clean the motor protection filter and, if necessary, replace the microhygiene filter or HEPA filter.

Care

Always switch off the vacuum cleaner and disconnect it from the mains before cleaning the vacuum cleaner. The vacuum cleaner and plastic accessories can be cleaned with ordinary plastic cleaner.

- ! Do not use abrasive materials, glass-cleaning agents or all-purpose cleaning products. Never immerse the vacuum cleaner in water.

If required, the dust compartment can be vacuumed out with a second vacuum cleaner or simply with a dry duster/dusting brush.

Subject to technical modifications.

GB Great Britain

BSH Home Appliances Ltd.
Grand Union House
Old Wolverton Road
Wolverton
Milton Keynes MK12 5PT

To arrange an engineer visit, to order spare parts and accessories or for product advice please visit

www.bosch-home.co.uk

or call

Tel.: 0844 892 8979*

*Calls from a BT landline will be charged at up to 3 pence per minute. A call set-up fee of up to 6 pence may apply.

HK Hong Kong, 香港

BSH Home Appliances Limited
Unit 1 & 2, 3rd Floor
North Block, Skyway House
3 Sham Mong Road
Tai Kok Tsui, Kowloon
Hong Kong
Tel.: 2565 6151
Fax: 2565 6681
mailto:bosch.hk.service@bshg.com
www.bosch-home.cn

SG Singapore, 新加坡

BSH Home Appliances Pte. Ltd.
TECHPLACE I and
Mo Kio Avenue 10
Block 4012 #01-01
569628 Singapore
Tel.: 6751 5000
Fax: 6751 5005
mailto:bshsgp.service@bshg.com
www.bosch-home.com.sg

Disposal information

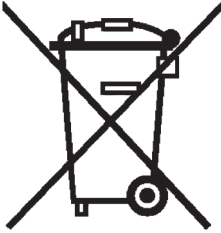

This appliance is labelled in accordance with European Directive 2012/19/EU concerning used electrical and electronic appliances (waste electrical and electronic equipment - WEEE). The guideline determines the framework for the return and recycling of used appliances as applicable throughout the EU.

■ Packaging

The packaging is designed to protect the vacuum cleaner from being damaged during transportation. It is made of environmentally friendly materials and can therefore be recycled. Dispose of packaging that is no longer required at an appropriate recycling point.

■ Old appliance

Old appliances still contain many valuable materials. Therefore, please take appliances that have reached the end of their service life to your retailer or recycling centre so that they can be recycled. For current disposal methods, please enquire at a retailer or your local council.

■ Disposal of filters and dust bags

Filters and dust bags are manufactured from environmentally friendly materials. Provided they do not contain substances that are not permitted in household waste, you can dispose of them with your normal household waste.

Conditions of guarantee

For this appliance the guarantee conditions as set out by our representatives in the country of sale apply. Details regarding same may be obtained from the dealer from whom the appliance was purchased. For claims under guarantee the sales receipt must be produced.

安全信息

感謝您購買博世GL40吸塵機。

本說明書為GL40系列通用，某些功能與配備或不適用於您的型號。請務必使用此吸塵機專用的博世原廠配件，以達到最佳吸塵效果。

請妥善保存本說明書。如果將此吸塵機轉交給他人，請同時轉交本說明書。

適用範圍

本機僅限於私人家庭及非商業環境中使用。本機適合在海拔最高 2,000 公尺以下使用。僅可依照使用說明書上的指示使用本吸塵器。

吸塵機必須配合以下使用：

- 原裝配件或特殊配件

為防止受傷和損壞，切勿將吸塵機用於：

- 清潔人或動物
- 吸取
 - 昆蟲或蜘蛛。
 - 危險、鋒利、發熱或灼熱的物質。
 - 潮濕或液態的物質。
 - 極易燃燒或爆炸的物質和氣體。
 - 由磚爐和中央供暖系統產生的灰及黑煙灰。
 - 打印機和複印機的碳粉塵。

安全信息

此吸塵機符合認可的技術規範和相關的安全守則。

- 在受監督，或已被指導如何安全使用，及理解使用此產品的潛在危險下，此產品可供8歲以上兒童，及行動不便、感覺或智力退化，及缺乏經驗或知識的人使用。
- 兒童絕不可將此產品當作玩具。
- 在沒有監督情況下，兒童絕不可以清潔及維修此產品。
- 塑料袋和薄膜在被棄置前必須放置於遠離兒童的位置。
=>有窒息的危險。

正確使用

- 請按指示牌上所列的規格要求連接和使用吸塵機。
- 切勿在無配備塵袋或容器、摩打保護或排氣濾網時吸塵。
=>這可能令吸塵機損壞。
- 使用刷頭和延伸管吸塵時切勿貼近頭部。
=>這可能導致受傷!
- 進行樓梯吸塵時，吸塵機必須經常保持放在使用者下方。
- 請勿使用電線或喉管拖曳吸塵機。
- 為安全起見，如果吸塵機主電源線損壞，請聯絡本公司客戶服務部安排合資格技師替換。
- 如吸塵持續數小時，請將電線完全拉出。
- 要切斷吸塵機電源時，請拔掉插頭，切勿拉扯電線。
- 請勿在鋒利邊上拉扯電線，或令電線纏繞。
- 要為吸塵機作出任何修整前，請先拔掉電源插頭。
- 請勿使用已損壞的吸塵機。如發現有異常情況，請切斷吸塵機電源。
- 為安全起見，只有本公司技師才可以維修和替換吸塵機配件。
- 請保護好吸塵機，勿暴露在惡劣天氣下，及潮濕和接近熱源的地方。
- 請勿把易燃物質或含酒精物質倒在濾網上(塵袋、摩打保護濾網、排氣濾網等)。
- 此吸塵機不適合在建築工地使用。
=>吸取建築碎屑可能會損壞吸塵機。
- 不使用時請關掉吸塵機。
- 當吸塵機的壽命完結時，應立即停止使用，然後以適當的方法棄置。

!

請注意

電源插座必須有至少16安培斷路器保護。開動吸塵機時如果斷路器跳擊，可能是有消耗較高電流的電器連接在同一電路上。為防止電流短路，請在開動吸塵機前選用最低功率，然後在運行時才將功率調高。

能源標籤的備註

本吸塵器為配備主要吸塵管之一般用途吸塵器。

如需在地毯和上達到標示的能源效益和清潔效果，請使用可替換的通用吸嘴。如需在硬質地板上達到標示的能源效益和清潔效果，請使用可替換的硬質地板吸嘴。

計算方式基於授權規定(歐盟)編號665/2013由委員會於2013年5月3日制訂以補充規範2010/30/EU的內容。

指示內未有詳述的所有程序已按照DIN EN 60312-1:2017*列出。

*由於馬達運轉試驗是在集塵容器為空時進行，在集塵容器半滿時，所述之馬達運轉壽命必須增加10%。

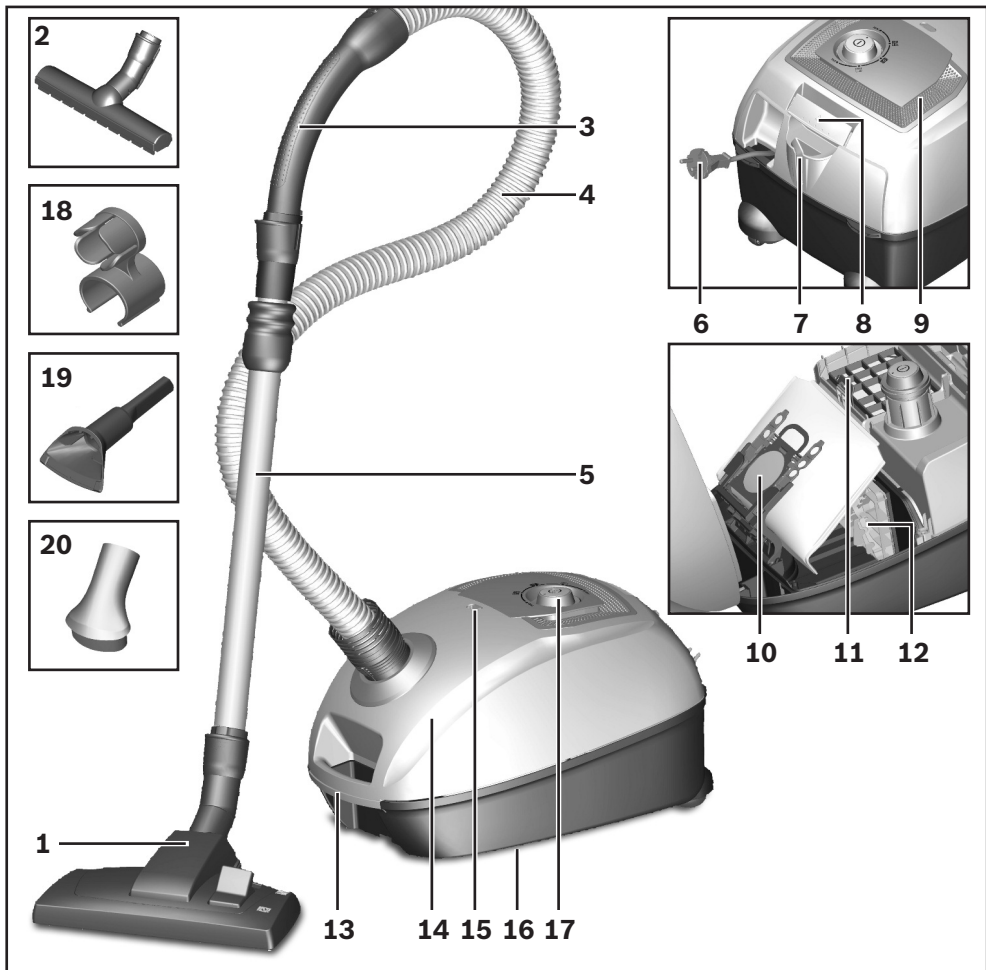

- | | |
|------------------|------------------|
| 1 可調式地板工具(含固定環) | 11 排氣濾網* |
| 2 硬質地板刷頭(含固定環) | 12 摩打保護濾網, 可清洗 |
| 3 軟管握柄 | 13 手把 |
| 4 伸縮軟管 | 14 塵袋艙 |
| 5 伸縮管含調整套筒(及固定環) | 15 塵袋更換指示器 |
| 6 電源線 | 16 存放輔助設計(在電器底部) |
| 7 輔助掛鉤 | 17 開關按鈕與功率控制器 |
| 8 鎖定撥片 | 18 多功能吸嘴專用的配件固定座 |
| 9 排氣柵 | 19 多功能吸嘴 |
| 10 塵袋 | 20 硬質傢俬刷頭 |

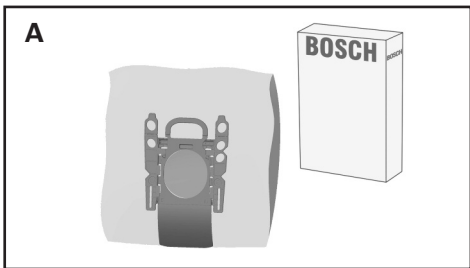

A 塵袋

為了達到最佳集塵效果，我們建議您使用PowerProtect原廠集塵袋(BBZ41FGALL)

內容：

- 4 個塵袋，含扣件
- 1 個微細濾網

！請注意

- 使用原廠塵袋，您的吸塵機才能達到最佳的清潔效果。只有使用高品質的原廠博世塵袋，才能達到歐盟能源標籤所標示的節能效率分級、吸力和集塵能力。如果使用品質不佳的塵袋(例如紙袋)，將會大幅影響電器使用壽命和效能。

未使用原廠博世塵袋或會導致保養失效。

關於訂購原廠博世塵袋的資訊，請瀏覽

www.bosch-home.com/dust-bag

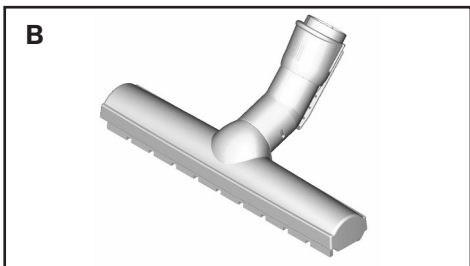

B 硬質地板刷頭BBZ123HD

硬質地板吸塵專用

(木質地板、瓷磚、紅土等)

首次使用電器前



圖 1

- 將握柄推入伸縮軟管並鎖至定位。
- 若要拆下握柄，請同時按下兩個固定扣，然後拉出伸縮軟管。

初次使用

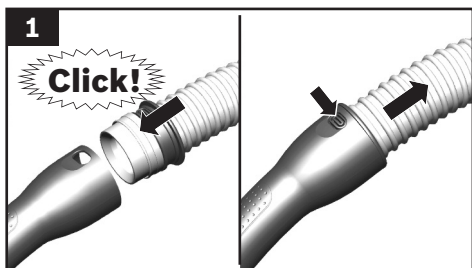

圖 2

- a) 將伸縮軟管推入吸塵機蓋的入氣開口，直到鎖定為止。
- b) 若要拆下伸縮軟管，請同時按下兩個固定扣，然後拉出軟管。

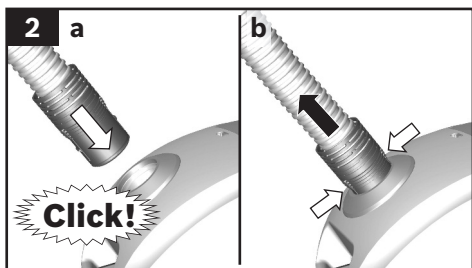

圖 3

- 將握柄推入伸縮管內直到卡住。若要將兩者分開，請擠壓套筒後再拉出握柄。

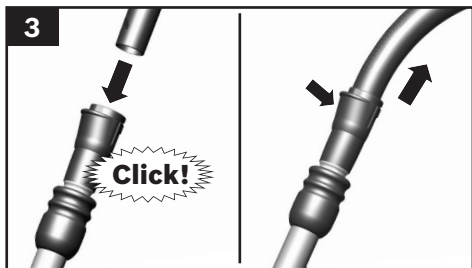

圖 4

- 將伸縮管推入地板工具的連接部分，直到鎖定為止。若要將兩者分開，請按住固定環並拉出伸縮管。

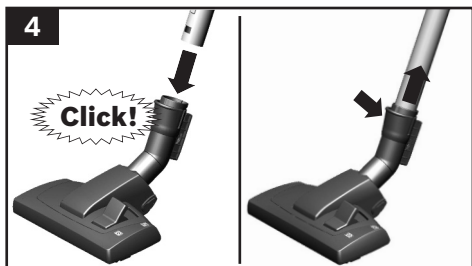

圖 5

- 依照箭頭方向移動調整套筒 / 滑動按鈕以解鎖伸縮管並調整所需長度。

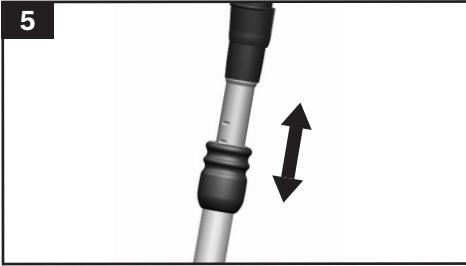

圖 6*

- 將多功能吸嘴安裝在配件座上，然後夾在吸塵管或伸縮管上。

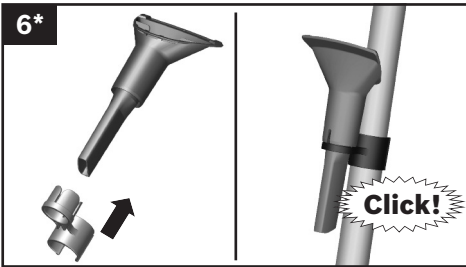

圖 7

- 抓住插頭，視乎所需長度拉出電源線，然後將插頭插入電源插座中。





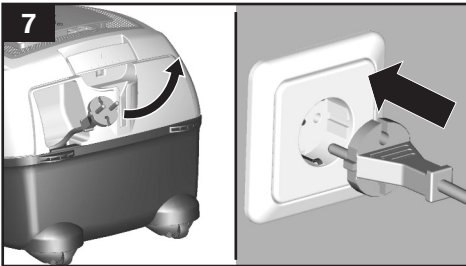

圖 8 開啟和關閉

- 依照箭頭方向按下開關按鈕，以啟動吸塵機。

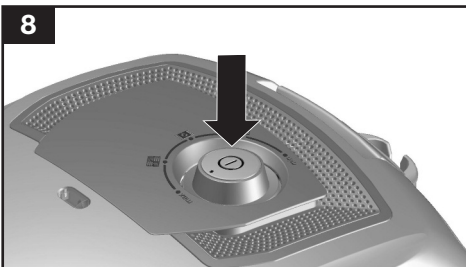

圖 9 控制吸力

若要調較所需吸力，請依照箭頭方向旋轉控制旋鈕。

- 低吸力
清理纖幼物品，例如墊毯類、窗簾等。 => 
- 中等吸力
日常清理少量灰塵。 => 
- 高吸力
清理抗磨的地板覆蓋物、硬質地板和非常骯髒的表面。 => 

吸塵

注意：

- 地板工具會受到一定程度的磨損，視乎地板的硬度而定(例如表面粗糙的瓷磚)。因此，每隔一段時間必須檢查地板工具的底部。地板工具底部因磨損所造成的尖銳表面或會造成拼花或亞麻地板等精緻的硬質地板表面受損。因磨損的地板工具所造成的損壞，製造商將不負任何責任。



圖 10

設定可調式地板吸嘴：

- 地墊或地毯 => 
- 硬質地板 => 

若要吸起較大的物件，請確認物件已連續地吸起，而且並未阻塞吸塵通道。您可以視乎需要抬起吸嘴，更易於吸入灰塵。

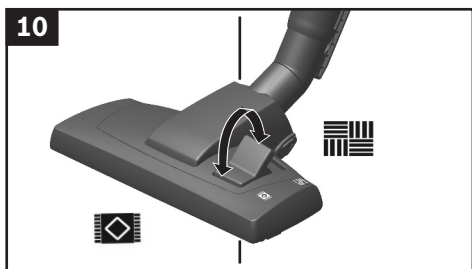

圖 11* 使用配件吸塵

視乎需要，在吸塵管或握柄上安裝吸嘴：

- a) 適合清理縫隙和角落等的尖頭吸嘴
- b) 適合軟墊傢俬、窗簾等的室內吸嘴
- c) 硬質傢俬刷頭專用的室內吸嘴

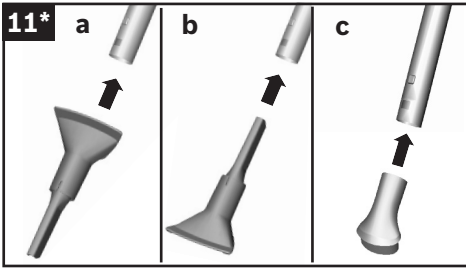
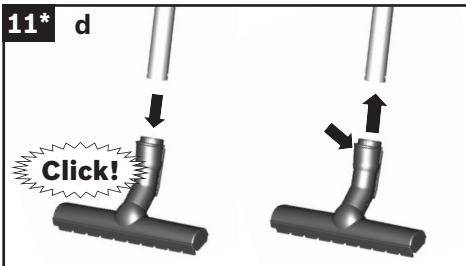

- d) 硬質地板工具
清理硬質地板覆蓋物
(瓷磚、拼花地板等)

- 將伸縮管推入硬質地板工具的連接部分，直到鎖定為止。
- 若要將兩者分開，請按住固定環並拉出伸縮管。

高速刷頭

相關的使用和維護說明，請參閱高速刷頭隨附的說明書。



圖 12

若您想暫停吸塵，可以使用吸塵機後方的輔助掛鉤。

- 關閉電器後，將地板工具上的掛鉤推入電器後方的凹槽。

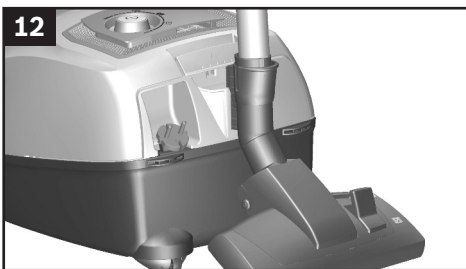

圖 13

電器上有一個手把，方便越過階梯等障礙物。

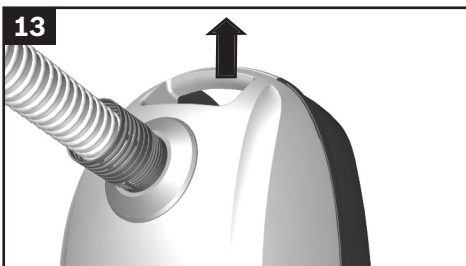

圖 14

- a) 請拔掉電源插頭。
- b) 稍微拉出電源線後放開(電源線將會自動捲回)。

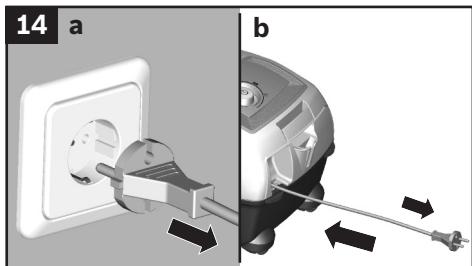

圖 15

若要放置 / 運送電器，您可以使用電器底部的存放輔助設計。

- a) 將電器立起。
- b) 將地板工具上的掛鉤推入電器後方的凹槽。

更換濾網

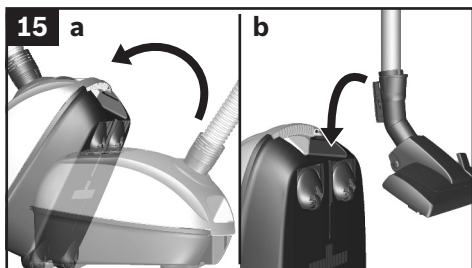
注意:更換濾網前必須將電器關掉。

更換塵袋



圖 16

- 当选择了最高吸尘水平将吸尘机从地面抬起时，如果盖子上的集尘袋更换指示器完全充满，那么，即便集尘袋可能还没有装满，也必须更换集尘袋。由于通过真空吸入的灰尘类型不一，即便集尘袋没有装满，也可能需要更换。首先检查吸嘴、吸尘管和活动软管是否堵塞，如有堵塞则可能触发集尘袋更换指示器。
- 先将握柄拆除，即可取出阻塞物體。

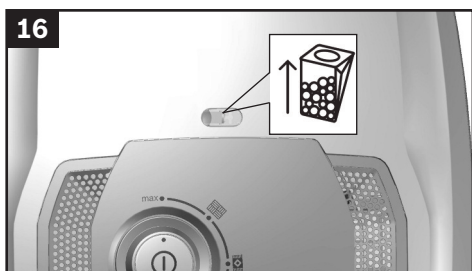

圖 17 打開蓋子

- a) 依箭頭方向拉起鎖定撥片。
- b) 依箭頭方向打開蓋子。

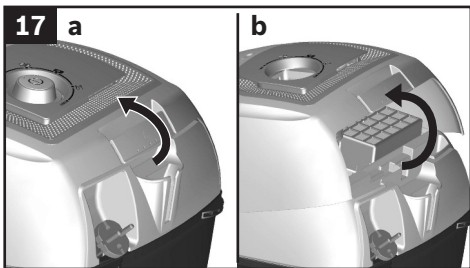

圖 18

- a) 拉起塵袋的凸出部分以關上塵袋。
- b) 取出塵袋。

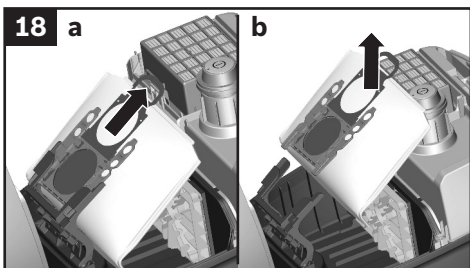
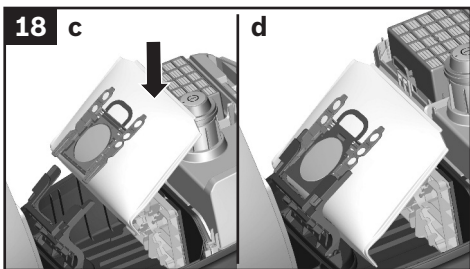

- c) 放入新塵袋。
- d) 將塵袋推回固定處。

❗ 請注意:如果未放入塵袋, 蓋子將無法關上。

清潔摩打保護濾網

應定期清潔摩打保護濾網上方的灰塵，並用水沖洗。



圖 19

打開塵袋艙。圖 17

- a) 請依照箭頭方向，將摩打保護濾網由側面解除固定並取出。
- b) 清理摩打保護濾網上的灰塵。

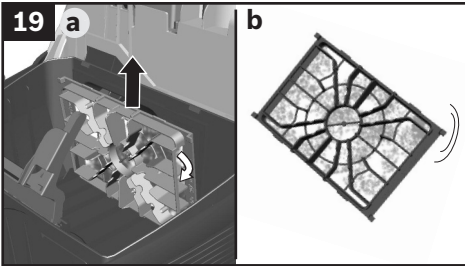
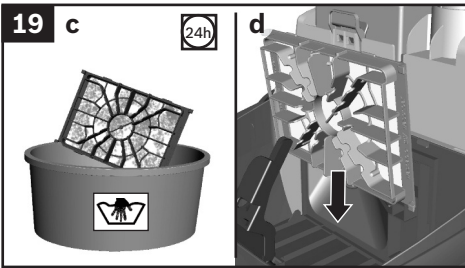

c) 如果摩打保護濾網非常骯髒，請以水沖洗。

- 濾網需要至少24小時晾乾。

d) 清洗完成後，將摩打保護濾網重新裝回並鎖定，然後關上塵袋艙。

更換排氣濾網

含微細濾網的吸塵機

請依照濾網替換包的指示更換



圖 20*

打開塵袋倉。圖 17

- 依照箭頭方向拆下濾網固定器。
- 取出微細濾網。

- 您可以用水沖洗微細濾網。
 - 濾網需要至少24小時晾乾。

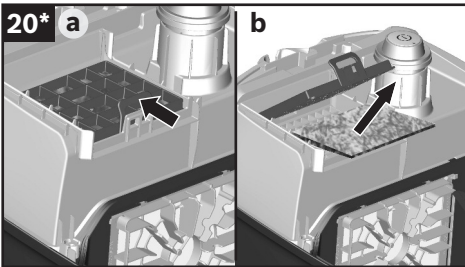
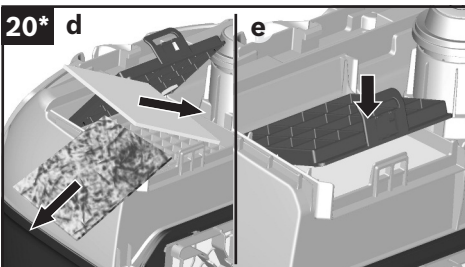

- 取出微細濾網。將新的微細濾網裝入電器中。
- 插入濾網固定器並固定。

更換排氣濾網

含HEPA濾網的吸塵機

吸塵機若配備HEPA濾網，則必須每年更換一次濾網。



圖 21*

打開塵袋艙。圖 17

- a) 依照箭頭方向移動鎖定撥片以解開HEPA濾網，然後取出濾網。
- b) 將新的HEPA濾網裝入定位。

清理細微灰塵後，請清潔摩打保護濾網，並視乎需要更換微細濾網或HEPA濾網。

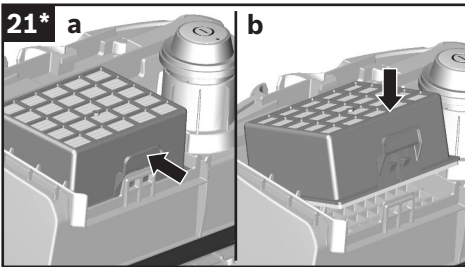
護理

清潔吸塵機前，請務必關閉吸塵機電源並拔下插頭。您可以使用一般塑膠清潔劑保養吸塵機和塑膠配件。

！切勿使用含研磨效果的物品、玻璃清潔劑或其他清潔產品。切勿將吸塵機浸在水中。

如有需要，可以使用其他吸塵機清潔塵袋艙，或用乾布 / 塵刷清潔。

本說明書可能因技術變更而修改。

GB Great Britain

BSH Home Appliances Ltd.
Grand Union House
Old Wolverton Road
Wolverton
Milton Keynes MK12 5PT

To arrange an engineer visit, to order spare parts and accessories or for product advice please visit

www.bosch-home.co.uk

or call

Tel.: 0844 892 8979*

*Calls from a BT landline will be charged at up to 3 pence per minute. A call set-up fee of up to 6 pence may apply.

HK Hong Kong, 香港

BSH Home Appliances Limited
Unit 1 & 2, 3rd Floor
North Block, Skyway House
3 Sham Mong Road
Tai Kok Tsui, Kowloon
Hong Kong
Tel.: 2565 6151
Fax: 2565 6681
mailto:bosch.hk.service@bshg.com
www.bosch-home.cn

SG Singapore, 新加坡

BSH Home Appliances Pte. Ltd.
TECHPLACE I and
Mo Kio Avenue 10
Block 4012 #01-01
569628 Singapore
Tel.: 6751 5000
Fax: 6751 5005
mailto:bshsgp.service@bshg.com
www.bosch-home.com.sg

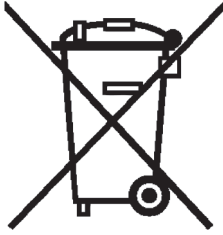

此吸塵機受歐盟2012/19/EU有關蓄電器及電子產品(廢棄電器和電子設備- WEEE)指引監管，該指引確立了適用於整個歐盟的蓄電器回收和再造的規章制度。

■ **包裝**

產品包裝旨在保護吸塵機於運輸過程中不受損壞，以環保材料製成，因此可被循環再造，不再需要找專門的回收點棄置。

■ **舊電器**

舊電器裡仍有很多可用的物料。因此，請將無法使用的電器送交零售商或回收中心，讓它們可循環再造。有關目前的棄置方法，請聯絡零售商或當地有關政府部門。

■ **棄置濾網及塵袋**

濾網及塵袋以環保材料製造。除了含有不能以家居廢物棄置的物質外，濾網及塵袋均可當作一般家居廢物處理



8001067002

970420