

SIEMENS



Free-standing appliance

KA..D..

siemens-home.com/welcome

en Installation instructions and instructions for use

Register
your
product
online

en Table of Contents

Safety and warning information	3
Information concerning disposal	4
Scope of delivery	4
Installing the appliance	5
Installation dimensions	6
Door opening angle	6
Aligning the appliance	7
Connecting the appliance	7
Removing appliance doors and handles	8
Getting to know your appliance	9
Switching the appliance on	11
Setting the temperature unit	11
Setting the temperature	11
Special functions	11
Sabbatical mode	13
Alarm function	13
Usable capacity	13
Freezer compartment	14
Max. freezing capacity	14
Freezing fresh food	14
Super freezing	15
Thawing frozen food	15
Refrigerator compartment	15
Super cooling	16
“Cool-fresh” container	16
Ice and water dispenser	17
Water filter	18
Specification and performance data sheet	19
Bar compartment	20
Features of the freezer compartment	20
Interior fittings of refrigerator compartment	21
Variable interior design	21
Switching off and disconnecting the appliance	22
Defrosting	22
Cleaning the appliance	23
Light	24
Tips for saving energy	25
Operating noises	25
Eliminating minor faults yourself	26
Appliance self-test	28
Customer service	28

⚠ Safety and warning information

Before you switch ON the appliance

Please read the operating and installation instructions carefully! They contain important information on how to install, use and maintain the appliance.

The manufacturer is not liable if you fail to comply with the instructions and warnings. Retain all documents for subsequent use or for the next owner.

Technical safety

The appliance contains a small quantity of environmentally friendly but flammable refrigerant R600a. Ensure that the tubing of the refrigerant circuit is not damaged during transportation and installation. Leaking refrigerant may cause eye injuries or ignite.

If damage has occurred

- Keep naked flames and/or ignition sources away from the appliance,
- thoroughly ventilate the room for several minutes,
- switch off the appliance and pull out the mains plug,
- inform customer service.

The more refrigerant an appliance contains, the larger the room must be in which the appliance is situated. Leaking refrigerant can form a flammable gas-air mixture in rooms which are too small.

The room must be at least 1 m³ per 8 g of refrigerant. The amount of refrigerant in your appliance is indicated on the rating plate inside the appliance.

If the power cord of this appliance is damaged, it must be replaced by the manufacturer, customer service or a similarly qualified person. Improper installations and repairs may put the user at considerable risk.

Repairs may be performed by the manufacturer, customer service or a similarly qualified person only.

Only original parts supplied by the manufacturer may be used. The manufacturer guarantees that only these parts satisfy the safety requirements.

A extension cable may be purchased from customer service only.

Important information when using the appliance

- Never use electrical appliances inside the appliance (e.g. heater, electric ice maker, etc.). Explosion hazard!
- Never defrost or clean the appliance with a steam cleaner! The steam may penetrate electrical parts and cause a short-circuit. Risk of electric shock!
- Do not use pointed and sharp-edged implements to remove frost or layers of ice. You could damage the refrigerant tubes. Leaking refrigerant may cause eye injuries or ignite.
- Do not store products which contain flammable propellants (e.g. spray cans) or explosive substances in the appliance. Explosion hazard!
- Do not stand on or lean heavily against base of appliance, drawers or doors, etc
- For cleaning pull out mains plug or switch off fuse. Do not pull out the mains plug by tugging on the power cord.
- Store high-percentage alcohol tightly closed and standing up.
- Keep plastic parts and the door seal free of oil and grease. Otherwise, parts and door seal will become porous.
- Never cover or block the ventilation openings of the appliance!
- **Avoiding placing children and vulnerable people at risk:**
At risk are children, people who have limited physical, mental or sensory abilities, as well as people who have inadequate knowledge concerning safe operation of the appliance.
Ensure that children and vulnerable people have understood the hazards. A person responsible for safety must supervise or instruct children and vulnerable people who are using the appliance.
Only children from 8 years and above may use the appliance.
Supervise children who are cleaning and maintaining the appliance.
Never allow children to play with the appliance.
- Do not store bottled or canned drinks (especially carbonated drinks) in the freezer compartment. Bottles and cans may burst!

- Never put frozen food straight from the freezer compartment into your mouth.
Risk of low-temperature burns!
- Avoid prolonged touching of frozen food, ice or the evaporator pipes, etc.
Risk of low-temperature burns!

Children in the household

- Keep children away from packaging and its parts.
Danger of suffocation from folding cartons and plastic film!
- Do not allow children to play with the appliance!
- If the appliance features a lock:
keep the key out of the reach of children!

General regulations

The appliance is suitable

- for refrigerating and freezing food,
- for making ice,
- for dispensing drinking water.

This appliance is intended for use in the home and the home environment.

The appliance is suppressed according to EU Directive 2004/108/EC.

The refrigeration circuit has been checked for leaks.

This product complies with the relevant safety regulations for electrical appliances (EN 60335-2-24).

This appliance is intended for use up to a maximum height of 2000 metres above sea level.

Information concerning disposal

Disposal of packaging

The packaging protects your appliance from damage during transit. All utilised materials are environmentally safe and recyclable. Please help us by disposing of the packaging in an environmentally friendly manner.

Please ask your dealer or inquire at your local authority about current means of disposal.

Disposal of your old appliance

Old appliances are not worthless rubbish! Valuable raw materials can be reclaimed by recycling old appliances.



This appliance is labelled in accordance with European Directive 2012/19/EU concerning used electrical and electronic appliances (waste electrical and electronic equipment - WEEE). The guideline determines the framework for the return and recycling of used appliances as applicable throughout the EU.

Warning

Redundant appliances

1. Pull out the mains plug.
2. Cut off the power cord and discard with the mains plug.
3. Do not take out the trays and receptacles: children are therefore prevented from climbing in!
4. Do not allow children to play with the appliance once it has spent its useful life. Danger of suffocation!

Refrigerators contain refrigerant and gases in the insulation. Refrigerant and gases must be disposed of professionally. Ensure that tubing of the refrigerant circuit is not damaged prior to proper disposal.

Scope of delivery

After unpacking all parts, check for any damage in transit.

If you have any complaints, please contact the dealer from whom you purchased the appliance or our customer service.

The delivery consists of the following parts:

- Free-standing appliance
- Interior fittings (depending on model)
- Bag containing installation materials
- Operating instructions
- Installation manual
- Customer service booklet
- Warranty enclosure
- Information on the energy consumption and noises

Installing the appliance

Transporting

The appliance is heavy. Secure in position during transportation and installation.

Due to the weight/dimensions of the appliance and to minimise the risk of injury and damage to the appliance at least two persons are necessary to set-up the appliance safely.

Installation location

Install the appliance in a dry, well ventilated room. The installation location should neither be exposed to direct sunlight nor near a heat source, e.g. a cooker, radiator, etc. If installation next to a heat source is unavoidable, use a suitable insulating plate or observe the following minimum distances to a heat source:

- 3 cm to electric or gas cookers.
- 30 cm to an oil or coal-fired cooker.

If installing the appliance next to another refrigerator or freezer, ensure a minimum lateral distance of 25 mm to prevent the formation of condensation.

If a panel or cupboard is installed above the appliance, ensure that a gap of 30 mm is left so that the appliance can be pulled out of the recess if required.

The air heated on the rear side of the appliance must be allowed to escape unhindered.

Subsurface

Caution

The appliance is very heavy.

Model with dispenser: 143 kg

The floor of the installation location must not give way; if required, reinforce floor.

To ensure that the doors can open all the way, observe lateral minimum distances when installing the appliance in a corner or recess (see chapter "Installation dimensions").

If the depth of the adjacent kitchen equipment is more than 60 cm, observe lateral minimum distances in order to utilise the full door opening angle (see chapter "Door opening angle").

Observe ambient temperature and ventilation

Ambient temperature

The climate class can be found on the rating plate. The climate class indicates within which ambient temperatures the appliance can be operated. The rating plate is located in the refrigerator compartment at the bottom right side.

Climate class	Permitted ambient temperature
SN	+10 °C to 32 °C
N	+16 °C to 32 °C
ST	+16 °C to 38 °C
T	+16 °C to 43 °C

Note

The appliance is fully functional within the room temperature limits of the indicated climatic class. If an appliance of climatic class SN is operated at colder room temperatures, the appliance will not be damaged up to a temperature of +5 °C.

Ventilation

Never cover the ventilation openings on the rear of the appliance. Conduction of the heated air must not be obstructed. Otherwise, the refrigeration unit must work harder. This increases power consumption.

Place the enclosed spacers in the designated holders on the back of the appliance. This ensures that there is a minimum distance between the appliance and the wall.

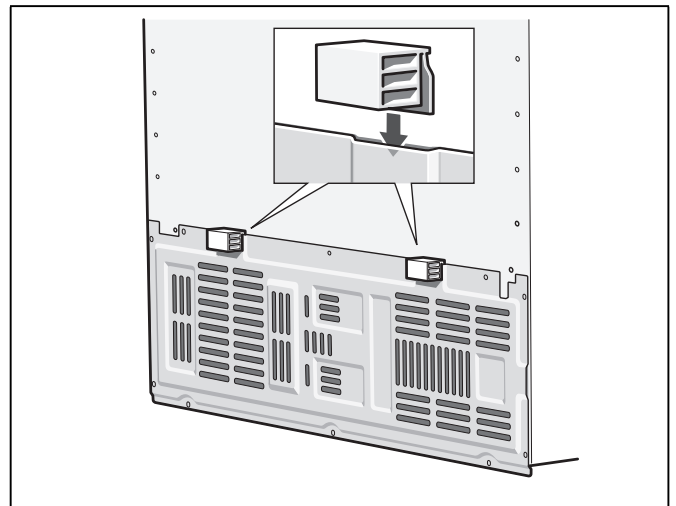

Installation dimensions

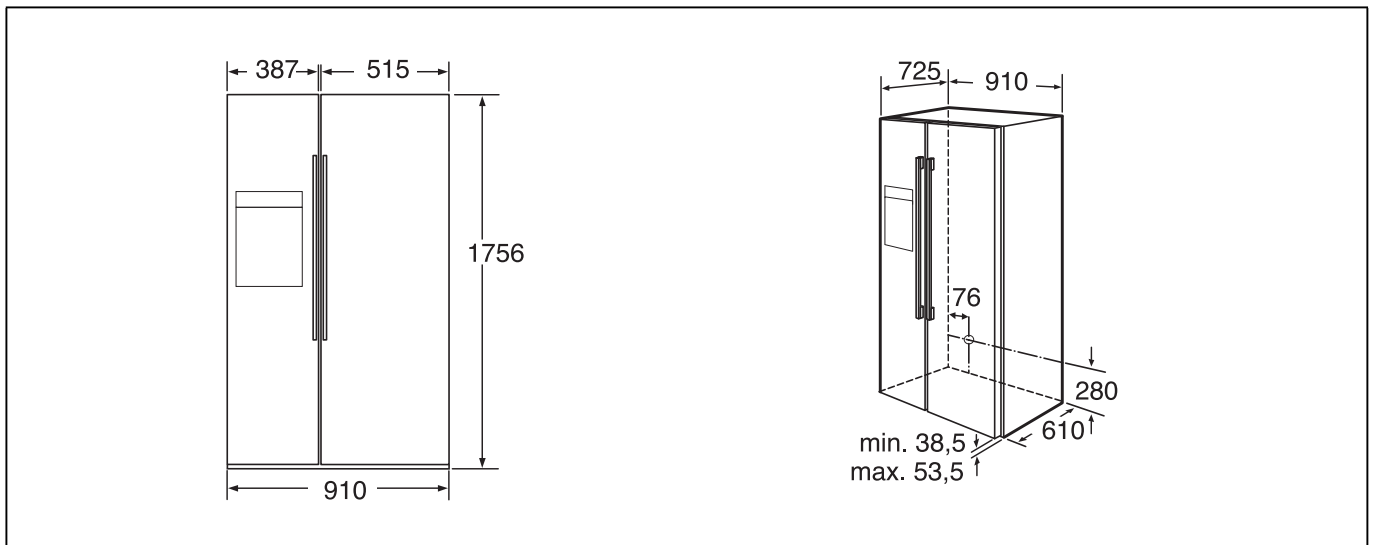

Door opening angle

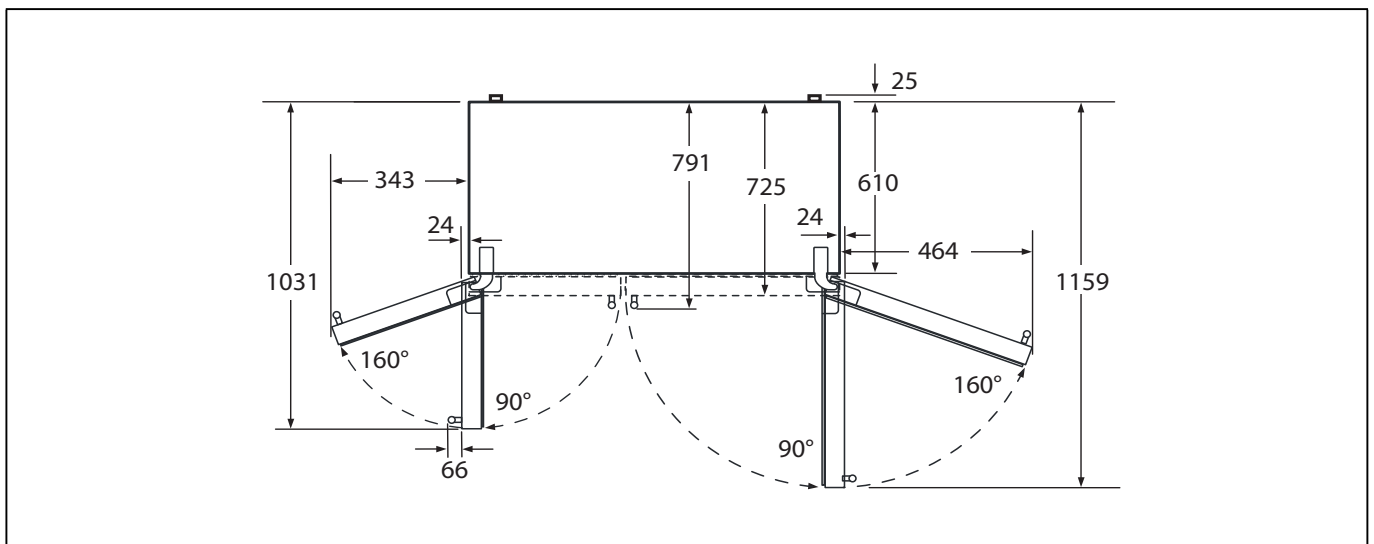

Aligning the appliance

To ensure that the appliance functions correctly, it must be set level with a spirit level.

If the appliance is not level, water may flow out of the ice maker, ice cubes may be irregular or the doors may not close properly.

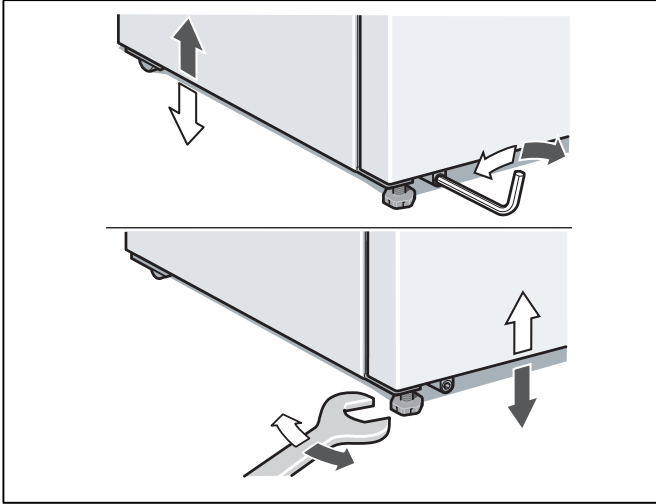

To align the appliance:

1. Place the appliance in the designated location.
2. Align front feet with a hexagon wrench.
3. Align rear feet with an Allen key.

Connecting the appliance

Have a technician install and connect the appliance according to the enclosed installation instructions.

Do not remove the transportation protection devices from the shelves and storage compartments until the appliance has been installed.

Always connect the water before the power.

Apart from statutory national regulations, you should stick to the connection terms relating to the local electricity and water companies.

After installing the appliance, wait at least 1 hour until the appliance starts up. During transportation the oil in the compressor may have flowed into the refrigeration system.

Before switching on the appliance for the first time, clean the interior of the appliance (see chapter "Cleaning the appliance").

Water connection

The water may be connected only by a competent fitter according to the local regulations of the appropriate water supply company.

⚠ Caution

Use only the enclosed hose set for connection to the drinking water mains. Do not use existing or already used hose sets.

Connect the appliance to a drinking water line only:

- Minimum pressure: 0.2 Mpa (2 bar)
- Maximum pressure: 0.8 Mpa (8 bar)
- Pressure over 0.8 MPa (8 bar): install a pressure limiter between drinking water connection and hose set

Note

The maximum outside diameter of the water mains (without connecting pieces) is 10 mm.

Electrical connection

Do not use extension cables or distributors. This appliance must be connected to a permanently installed socket.

The socket must be near the appliance and also freely accessible following installation of the appliance.

The appliance complies with the protection class I. Connect the appliance to 220-240 V/50 Hz alternating current via a correctly installed socket with protective conductor. The socket must be fused with a 10 A to 16 A fuse or higher.

For appliances operated in non-European countries, the identification plate should be checked whether the electric supply and the current model stated match the values of your mains supply. The rating plate is situated in the bottom right-hand side of the appliance. The power cord may be replaced by a technician only.

⚠ Warning

Never connect the appliance to electronic energy saver plugs.

Our appliances can be used with mains and sine-controlled inverters. Mains-controlled inverters are used for photovoltaic systems which are connected directly to the national grid. Sine-controlled inverters must be used for isolated applications (e.g. on ships or in mountain lodges) which are not connected directly to the national grid.

Removing appliance doors and handles

If the appliance will not fit through the house door, the appliance doors and handles can be unscrewed.

⚠ Caution

Only customer service may unscrew the appliance doors.

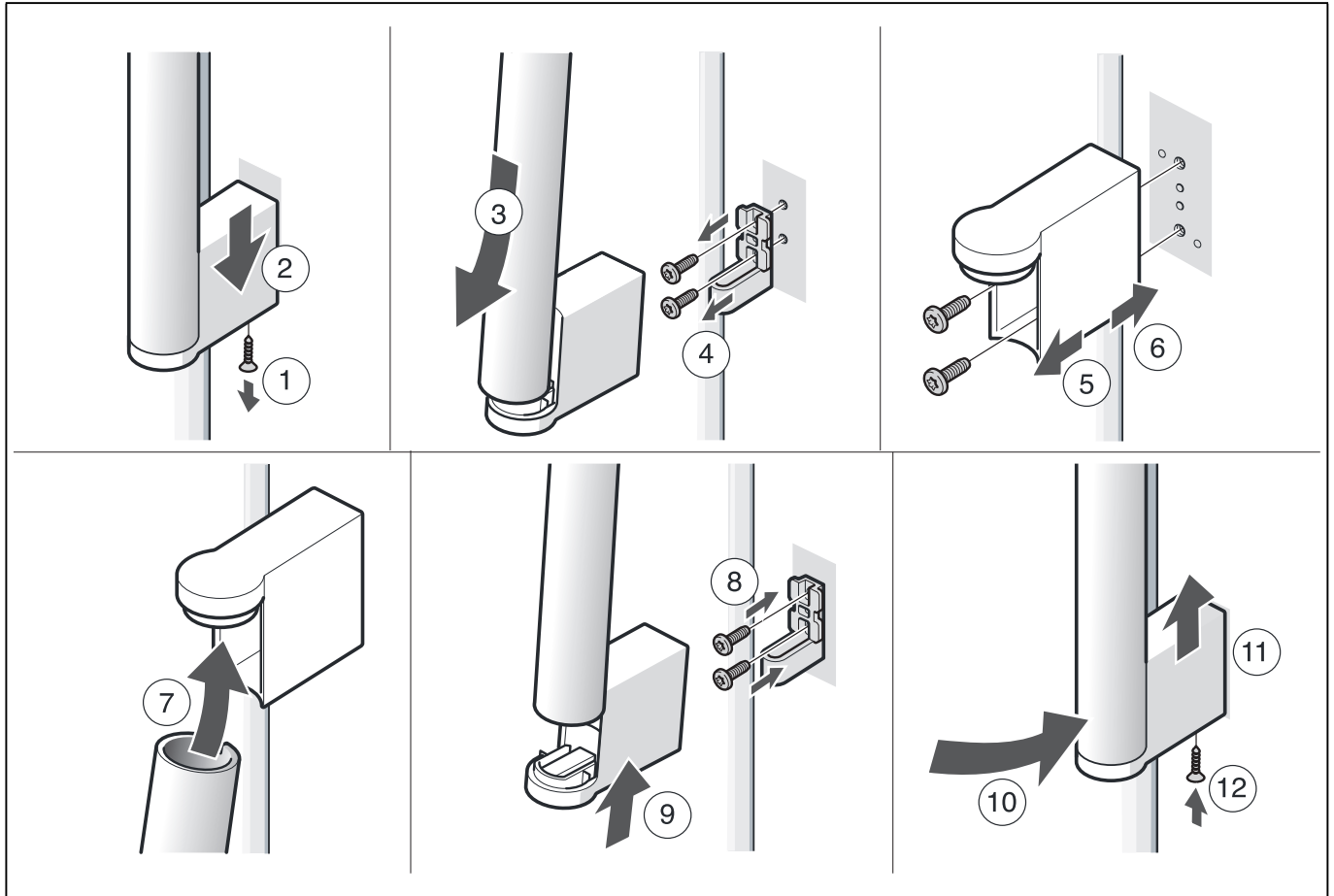

Getting to know your appliance

These operating instructions refer to several models. The diagrams may differ.

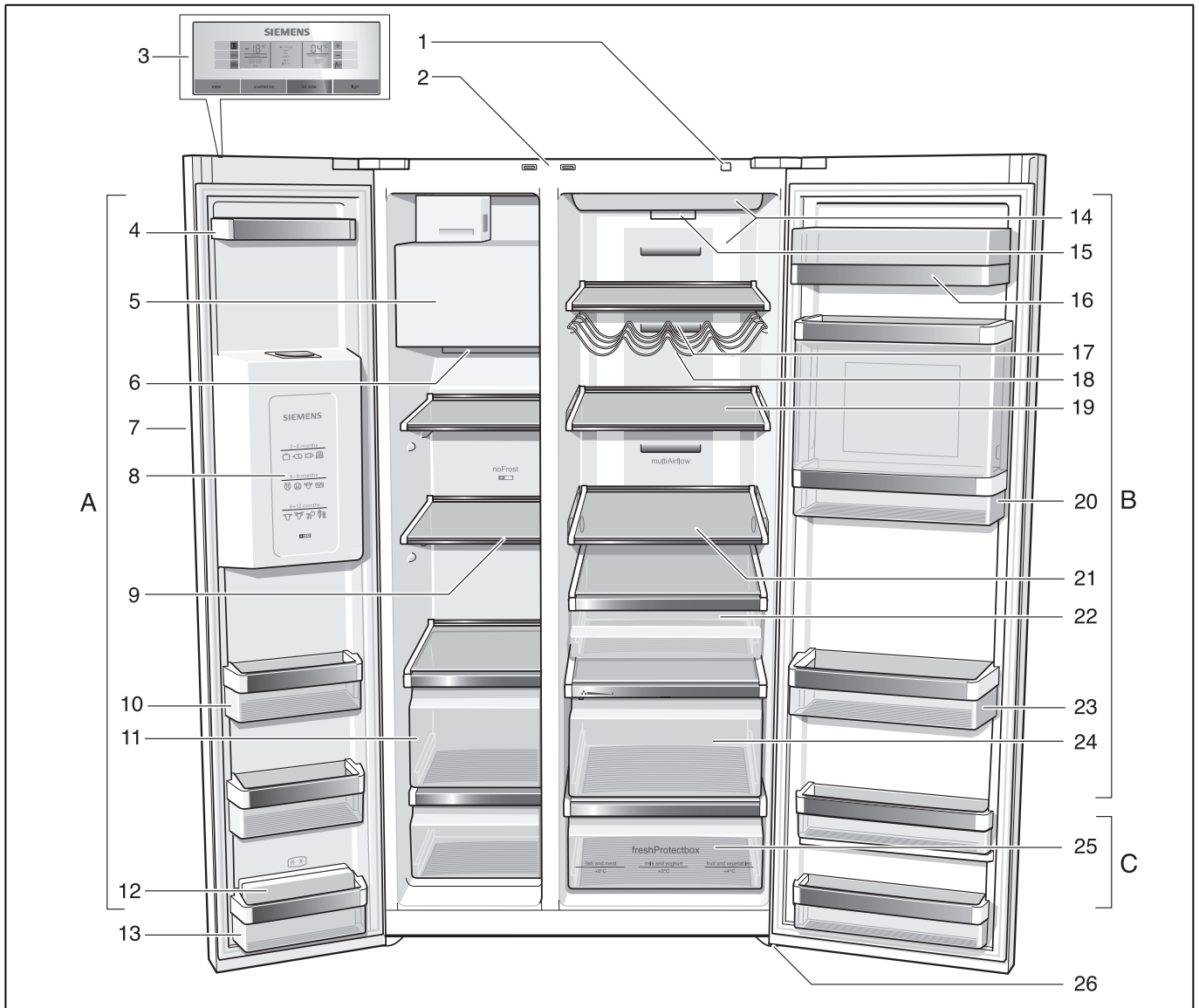

* Not all models.

- | | |
|--|---|
| <p>A Freezer compartment</p> <p>B Refrigerator compartment</p> <p>C Cool-fresh compartment</p> <p>1 On/Off button</p> <p>2 Light switch for refrigerator and freezer compartments</p> <p>3 Control and display panel</p> <p>4 Door shelf</p> <p>5 Ice maker/Ice cube container</p> <p>6 Air outlet opening</p> <p>7 Ice and water dispenser</p> <p>8 Freezer calendar</p> <p>9 Glass shelf in the freezer compartment</p> <p>10 Door shelf</p> <p>11 Frozen food container</p> | <p>12 Ice pack *</p> <p>13 Door shelf (2 star compartment) for short-term storage of food and ice cream</p> <p>14 Light</p> <p>15 Particle filter/Water filter</p> <p>16 Butter and cheese compartment</p> <p>17 Air outlet opening</p> <p>18 Bottle shelf *</p> <p>19 Glass shelf in the refrigerator compartment</p> <p>20 Bar compartment *</p> <p>21 Adjustable glass shelf</p> <p>22 Delicatessen container</p> <p>23 Shelf for large bottles</p> <p>24 Vegetable container with humidity filter</p> <p>25 "Cool-fresh" container</p> <p>26 Height-adjustable feet</p> |
|--|---|

Control and display panel

The display panel and display panel on the door consists of a touch pad.
Touch the keypad to actuate the corresponding function.

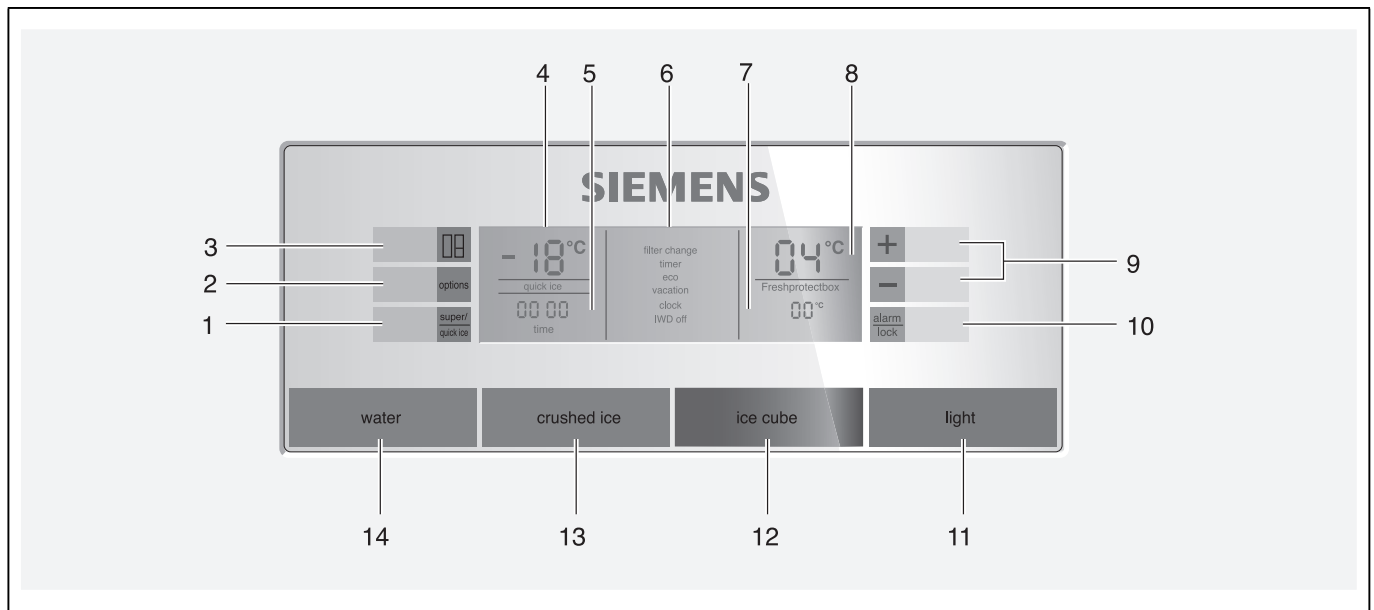

1 "super/quick ice" button

The button is used to

- switch on the super cooling (refrigerator compartment) or super freezing (freezer compartment) function (see chapter entitled "Super cooling" or "Super freezing").
- activate the [quick ice] function (see chapter "Special functions").

2 "options" button

For selecting the special functions. Keep pressing the button until the required function is selected with an arrow (see chapter entitled "Special functions").

3 "select" button

For making settings in the different temperature zones (freezer compartment, refrigerator compartment, "cool-fresh" container). Keep pressing the button until the required zone is marked with an arrow.

4 Freezer compartment display

Indicates the current temperature setting in the freezer compartment.

5 Time display

Displays the current time or the time sequence when a special function of the timer is activated.

6 Special functions display

Indicates the available special functions (see chapter "Special functions").

7 "Cool-fresh" container display

Indicates the current temperature setting in the "cool-fresh" container.

8 Refrigerator compartment display

Indicates the current temperature setting in the refrigerator compartment.

9 Setting buttons +/-

The buttons are used to

- set the temperatures in the different cooling zones,
- switch the special functions on and off,
- change the time setting of the "timer" special function.

10 "alarm/lock" button

The button is used to

- switch off the warning signal (see chapter Alarm function),
- switch the button lock on and off.

To switch the button lock on and off, press button for 5 seconds. When the function is switched on, "lock" is indicated on the display panel.

Except the button lock:

If a warning signal sounds, the "alarm/lock" button can be pressed.

11 On/Off "light" button for ice and water dispenser

12 Ice dispenser button

13 Dispenser button for crushed ice

14 Water dispenser button

Switching the appliance on

Switch on the appliance with the ON/OFF button. A warning signal sounds.

Press the "alarm/lock" button. The warning signal switches off.

Display "alarm" goes out when the appliance has reached the set temperature.

The preset temperatures are reached after several hours. Do not put any food in the appliance beforehand.

The factory has recommended the following temperatures:

- Freezer compartment: -18 °C
- Refrigerator compartment: +4 °C
- "Cool-fresh" container: +2 °C

Setting the temperature unit

The temperature can be displayed in degrees Celsius (°C) or degrees Fahrenheit (°F).

Setting the temperature unit

To set the temperature unit, simultaneously press the "super/quick ice" button and the "options" button for 5 seconds.

Depending on the previous setting, the display switches to the other temperature unit.

Setting the temperature

The required area must be selected before temperatures can be set for the different climatic zones (refrigerator compartment, freezer compartment, "cool-fresh" container):

1. Keep pressing the "select" button until the required climatic zone is marked with an arrow.
2. Set the temperature with the + (warmer) or - (cooler) setting buttons.

The value last indicated is saved by the system.

Freezer compartment

The freezer compartment can be set from -14 °C to -24 °C.

We recommend a setting of -18 °C.

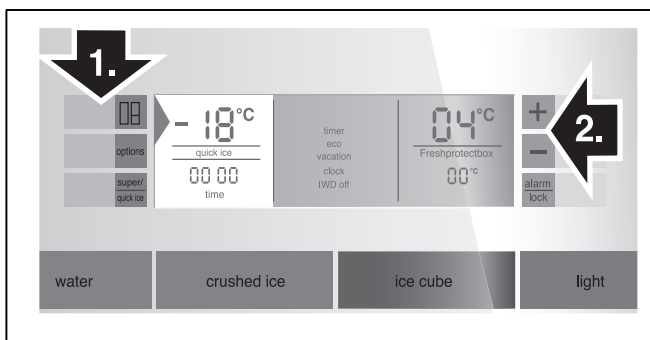

Refrigerator compartment

The refrigerator compartment can be set from +2 °C to +8 °C.

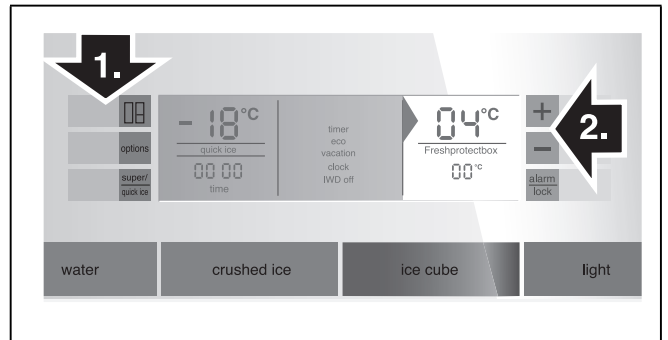

The temperature can be set at 1 °C intervals.

Perishable food should not be stored above +4 °C.

We recommend a setting of +4 °C.

"Cool-fresh" container

The "cool-fresh" container can be set within temperature ranges of 0 °C/+2 °C/+4 °C.

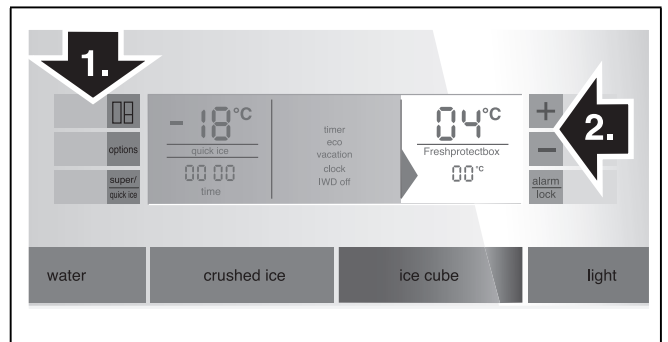

Special functions

[timer]

You can use this function to set a period of time of 0-99 minutes. A signal reminds you, e.g. when food is to be taken out of the compartment after a certain time. A value of 20 minutes has been preset at the factory.

⚠ Caution

Drinks bottles may crack if they are stored for longer than 20 minutes in the freezer compartment.

Switching on the [timer]

1. Keep pressing the "options" button, until the [timer] function is marked with an arrow.
2. Activate by pressing the setting button + (function is framed).
3. Press the setting buttons +/- to set the required time.

Note

Repeatedly press the button to change the time in one minute intervals. If the button is held down, the time changes in 3 minute intervals.

4. Press the "options" button to start the time cycle.

Switching off [timer]

To deactivate the function, simultaneously press the setting buttons + and - for 3 seconds.

[eco]

This function switches the appliance to energy-saving mode.

The appliance automatically sets the following temperatures:

- Freezer compartment: -16 °C
- Refrigerator compartment: +6 °C

Switching on the [eco]

1. Keep pressing the “options” button, until the [eco] function is marked with an arrow.
2. Activate by pressing the setting button + (function is framed).

Switching off the [eco]

1. Keep pressing the “options” button, until the [eco] function is marked with an arrow.
2. Deactivate by pressing the setting button - (function is no longer framed).

[vacation]

If leaving the appliance for a long period of time, you can switch the appliance over to the energy-saving vacation mode. The refrigerator compartment temperature is automatically switched to +14 °C.

⚠ Caution

Do not store any food in the refrigerator compartment during this time!

Switching on the [vacation]

1. Keep pressing the “options” button, until the [vacation] function is marked with an arrow.
2. Activate by pressing the setting button + (function is framed).

Switching off the [vacation]

1. Keep pressing the “options” button, until the [vacation] function is marked with an arrow.
2. Deactivate by pressing the setting button - (function is no longer framed).

[clock]

The time is indicated on the time display panel. You can set the time with the [clock] function.

Setting the time

1. Keep pressing the “options” button, until the [clock] function is marked with an arrow.
2. Activate by pressing the setting button + (function is framed).
3. Press the setting buttons +/- to set the required time.
4. Save the set time with the “options” button.

Note

If the [timer] function is switched on, the time is not displayed.

[IWD off]

You can use this function to switch off the ice and water dispenser.

⚠ Caution

- Before switching off the ice maker, it is most important that you switch the water supply to the appliance off for a few hours.
- Empty and clean ice cube container. Re-attach the ice cube container. Ensure that the ice cube container engages with the support.

Switching on [IWD off]

1. Keep pressing the “options” button, until the [IWD off] function is marked with an arrow.
2. Activate by pressing the setting button + (function is framed).

Switching off [IWD off]

1. Keep pressing the “options” button, until the [IWD off] function is marked with an arrow.
2. Deactivate by pressing the setting button - (function is no longer framed).

[quick ice]

You can use this function to accelerate the production of ice cubes.

Switching [quick ice] on and off

1. Activate by pressing “super/quick ice” button. [quick ice] is indicated on the display panel.

Notes

- The [quick ice] function can only be activated if the freezer compartment, refrigerator compartment and “cool-fresh” container displays have not been selected.
 - If the function is activated, the power of your appliance is increased intermittently. This increases the energy consumption.
2. Deactivate by pressing “super/quick ice” button.

[filter change]

After 6 months you are prompted via the [filter change] display message to replace the filter cartridge.

Activating new filter cartridge

When the filter cartridge has been replaced, the [filter change] function must be re-activated.

1. Change filter cartridge (see chapter “Water filter”).
2. Keep pressing the “options” button, until the [filter change] function is marked with an arrow.
3. Activate by pressing the setting buttons +/- . [filter change] display goes out.

Sabbatical mode

Sabbatical mode settings:

- Accoustic signal is switched off.
- Super cooling or super freezing is then ended (if activated).
- The light is switched off.
- The light on the display panel is reduced to basic lighting.
- Buttons are locked (except “options” button and setting button +).

Switching sabbatical mode on and off

1. To activate, simultaneously press the “options” button and setting button + for 5 seconds. [sabbath] is redisplayed on the display panel.
2. To deactivate, simultaneously press the “options” button and setting button + for 5 seconds.

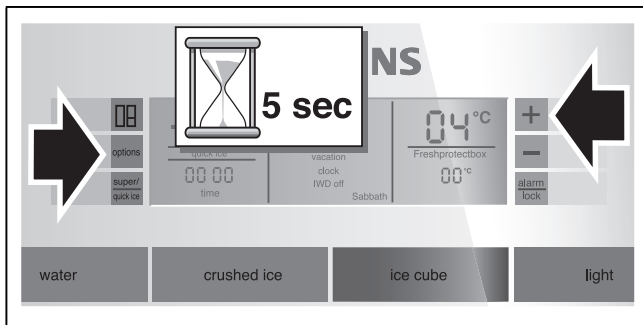

Alarm function

Press the “alarm/lock” button to switch off the warning signal.

In the following cases an alarm may be actuated:

Door opening alarm

If the appliance is left open for longer than one minute, the door alarm (continuous sound) switches on. Close the door or press the Alarm button to switch the warning signal off again.

Temperature alarm

The temperature alarm switches on if the freezer and refrigerator compartment is too warm and the food is at risk of thawing.

The acoustic and optical signals may be actuated without risk to the frozen food when:

- The appliance is switched on.
- Large quantities of fresh food are placed in the freezer.

Freezer compartment

“AL” flashes on the freezer compartment display panel and “alarm” is displayed.

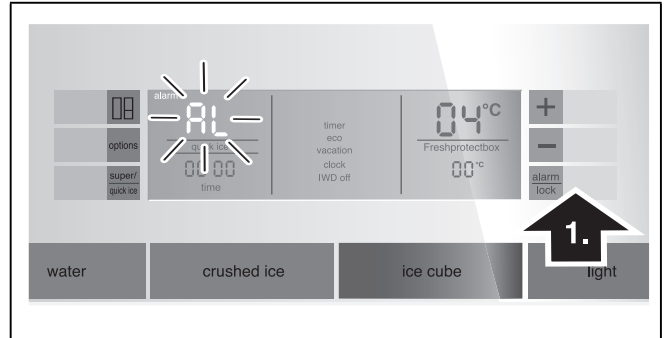

The temperature display indicates for 10 seconds the warmest temperature which was reached in the freezer compartment. Then the set temperature is displayed again.

The alarm display goes out as soon as the set temperature has been reached again.

Note

Do not refreeze thawing or thawed food. Only ready meals (boiled or fried) may be refrozen.

No longer store the frozen produce for the max. storage period.

Refrigerator compartment

“AL” flashes on the refrigerator compartment display panel and “alarm” is displayed.

⚠ Caution

If the refrigerator compartment has become too warm, cook warmed refrigerated food before consumption. If in doubt, do not use raw food.

Usable capacity

Information on the usable capacity can be found inside your appliance on the rating plate (see diagram at chapter “Customer service”).

Fully utilising the freezer volume

To place the maximum amount of food in the freezer, the top frozen food container can be taken out of the appliance. The food can then be placed directly on the shelves and stacked in the lower frozen food container.

Freezer compartment

Use the freezer compartment

- To store deep-frozen food.
- To make ice cubes.
- To freeze food.

Note

Ensure that the freezer compartment door has been closed properly. If the door is open, the frozen food will thaw. The freezer compartment will become covered in thick ice. Also: waste of energy due to high power consumption!

When the freezer compartment door is closed, a low pressure occurs, causing a sucking noise. Wait two to three minutes until the low pressure has adjusted itself.

We recommend leaving the ice cube container in the appliance. This ensures optimum temperature distribution in the freezer compartment.

Purchasing frozen food

- Packaging must not be damaged.
- Use by the “use by” date.
- Temperature in the supermarket freezer must be -18 °C or lower.
- If possible, transport deep-frozen food in an insulated bag and place quickly in the freezer compartment.

Max. freezing capacity

Information about the max. freezing capacity within 24 hours can be found on the rating plate (see diagram at chapter “Customer service”).

Freezing fresh food

Freeze fresh and undamaged food only.

To retain the best possible nutritional value, flavour and colour, vegetables should be blanched before freezing. Aubergines, peppers, zucchini and asparagus do not require blanching.

Literature on freezing and blanching can be found in bookshops.

Note

Keep food which is to be frozen away from food which is already frozen.

- The following foods are suitable for freezing:
 - Cakes and pastries, fish and seafood, meat, game, poultry, vegetables, fruit, herbs, eggs without shells, dairy products such as cheese, butter and quark, ready meals and leftovers such as soups, stews, cooked meat and fish, potato dishes, soufflés and desserts.
- The following foods are not suitable for freezing:
 - Types of vegetables, which are usually consumed raw, such as lettuce or radishes, eggs in shells, grapes, whole apples, pears and peaches, hard-boiled eggs, yoghurt, soured milk, sour cream, crème fraîche and mayonnaise.

Packing frozen food

To prevent food from losing its flavour or drying out, place in airtight containers.

1. Place food in packaging.
2. Remove air.
3. Seal the wrapping.
4. Label packaging with contents and date of freezing.

Suitable packaging:

Plastic film, tubular film made of polyethylene, aluminium foil, freezer containers.

These products are available from specialist outlets.

Unsuitable packaging:

Wrapping paper, greaseproof paper, cellophane, bin liners and used shopping bags.

Items suitable for sealing packaged food:

Rubber bands, plastic clips, string, cold-resistant adhesive tape, etc.

Bags and tubular film made of polyethylene can be sealed with a film heat sealer.

Shelf life of frozen food

Storage duration depends on the type of food.

At a temperature of -18 °C:

- Fish, sausage, ready meals and cakes and pastries:
 - up to 6 months
- Cheese, poultry and meat:
 - up to 8 months
- Vegetables and fruit:
 - up to 12 months

Super freezing

Food should be frozen solid as quickly as possible in order to retain vitamins, nutritional value, appearance and flavour.

Several hours before placing fresh food in the freezer compartment, switch on super freezing to prevent an unwanted temperature rise.

As a rule, 4–6 hours is adequate.

This appliance runs constantly and the freezer compartment drops to a very low temperature.

If the max. freezing capacity is to be used, super freezing must be switched on for 24 hours before the fresh produce is placed in the freezer compartment.

You can freeze smaller quantities of food (up to 2 kg) without fast freezing.

Note

When super freezing is switched on, increased operating noises may occur.

Switching on Super freezing

1. Keep pressing the “select” button until the freezer compartment climate zone is marked with an arrow.
2. Press “super/quick ice” button.

If “super freezing” is switched on, “SU” and “super” are indicated on the display panel.

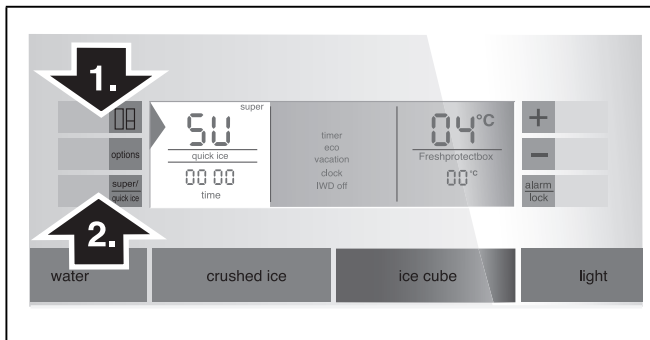

Switching off Super freezing

1. Keep pressing the “select” button until the freezer compartment climate zone is marked with an arrow.
2. Press “super/quick ice” button.

If super freezing is switched off, “SU” and “super” go out on the display panel.

Note

Super freezing automatically switches off after approx. 2½ days.

Thawing frozen food

Depending on the type and application, select one of the following options:

- at room temperature
- in the refrigerator
- in an electric oven, with/without fan assisted hot-air
- in the microwave

⚠ Caution

Do not refreeze thawing or thawed food. Only ready meals (boiled or fried) may be refrozen.

No longer store the frozen produce for the max. storage period.

Refrigerator compartment

The refrigerator compartment is the ideal storage location for ready meals, cakes and pastries, preserved food, condensed milk and hard cheese.

Arranging food in the appliance

- Wrap or cover food before placing in the appliance. This will retain the aroma, colour and freshness of the food. In addition, flavours will not be transferred between foods and the plastic parts will not become discoloured.
- Allow warm food and drinks to cool down before placing in the appliance.
- Do not block air outlet openings with food, otherwise the air circulation will be impaired. Food which is stored directly in front of the air outlet openings may be frozen by the cold air flowing out.
- Keep plastic parts and the door seals free of oil and grease.
- Bottles which contain a high percentage of alcohol must be sealed and stored in an upright position.

Super cooling

Super cooling sets the refrigerator temperature to the coldest temperature setting for approx. 6 hours. Then the appliance automatically switches to the temperature set prior to super cooling mode.

Switch on super cooling mode, e.g.

- before placing large quantities of food in the refrigerator compartment.
- for the fast cooling of drinks.

Note

When super cooling is switched on, increased operating noises may occur.

Switching on Super cooling

1. Keep pressing the “select” button until the refrigerator compartment climate zone is marked with an arrow.
2. Press “super/quick ice” button.

If “super cooling” is switched on, “SU” and “super” are indicated on the display panel.

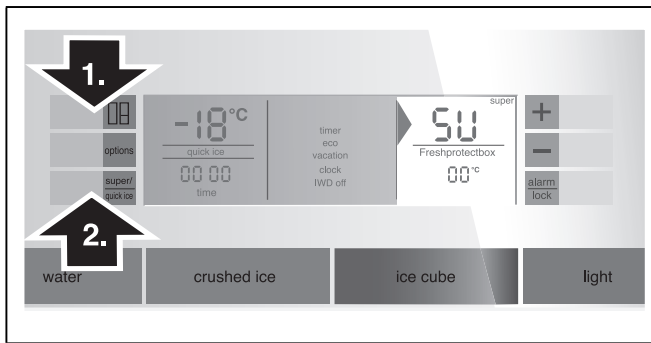

Switching off Super cooling

1. Keep pressing the “select” button until the refrigerator compartment climate zone is marked with an arrow.
2. Press “super/quick ice” button.

If super cooling is switched off, “SU” and “super” go out on the display panel.

“Cool-fresh” container

(not all models)

The temperature in the “cool-fresh” container is about 0 °C. The low temperature and the optimum moisture provide ideal storage conditions for fresh food.

Food can be kept fresh up to three times longer than in the normal cooling zone – for even longer freshness, nutrient retention and flavour.

Select the temperature to be set according to the food in the “cool-fresh” container:

- fish and meat, 0 °C
- milk and yoghurt, +2 °C
- fruit and vegetables, +4 °C

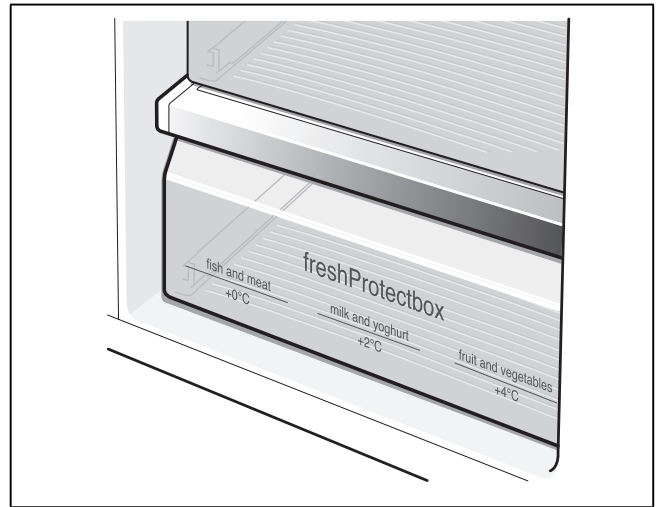

Foods suitable for “cool-fresh” container:

In principle all foods which are fresh and are to remain fresh for even longer, such as: fish, seafood, meat and sausage, dairy products, and ready meals.

Foods not suitable for the “cool-fresh” drawer:

Fruit and vegetables sensitive to cold (e.g.: tropical fruit such as pineapples, bananas, papaya, citrus fruits, melons as well as tomatoes, aubergines, zucchini, capsicums, cucumbers, potatoes).

The ideal storage location for these foods is the refrigerator compartment.

When purchasing food, please note:

The “purchase freshness” is important for the shelf-life of your food.

In principle, the following applies: the fresher you store the food in the appliance, the longer it will remain fresh. Therefore, when buying food, pay attention to the degree of freshness.

In the case of ready-made products and bottled goods, observe the best-before date or use-by date specified by the manufacturer.

Ice and water dispenser

The following can be dispensed as required:

- cooled water,
- crushed ice,
- ice cubes.

⚠ Warning

Never reach into the ice cube dispenser opening! **Risk of injury!**

⚠ Caution

Do not place bottles or food in the cube container in order to cool them quickly. The ice maker may block and be damaged.

* Not all models.

Using the ice and water dispenser

The ice and water dispenser only works when the appliance is connected to the water mains.

When the appliance has been switched on, it takes approx. 24 hours until the first batch of ice cubes are ready.

When the appliance has been connected, there are still air bubbles in the lines.

Run off drinking water and pour away until water can be dispensed without bubbles. Pour away the first 5 glasses.

When using the ice maker for the first time, do not use the first 30-40 ice cubes for reasons of hygiene.

Operating the ice maker

As soon as the freezer compartment has reached its freezing temperature, ice cube production starts. After 2-3 hours the ready ice cubes are automatically discharged into the ice cube container.

Note

The appliance produces more ice if you lower the freezer compartment temperature. This will slightly increase the energy consumption of your appliance.

Occasionally ice cubes will freeze together and block the dispenser:

1. Open the door and check inside whether ice cubes are sticking to the ice and water dispenser.
2. If the ice and water dispenser is not blocked:

⚠ Caution

A full ice cube container is heavy!

- Carefully pull out ice cube container and remove ice cubes which are frozen together.

When the ice cube container is full, ice making switches off automatically.

When ice cubes are being made, the buzzing water valve, the water flowing into the ice cube tray and the falling ice cubes can be heard.

Observing drinking water quality

All materials used in the drinks dispenser are odourless and tasteless.

If the water has an aftertaste, this may be caused by:

- Mineral and chlorine content of the drinking water.
- Material of the domestic water line and connection line.
- Freshness of the drinking water. If water has not been dispensed for a long time, the water may have a "stale" taste. In this case fill approx. 15 glasses of water and throw away.

We recommend that you regularly dispense a little fresh water from the water maker and that you do not switch off the appliance. This will ensure that the best water quality is retained.

The enclosed water filter will filter only particles out of the supply water, not bacteria or microbes.

Dispensing ice/water

- Select the ice and water dispenser button (water, crushed ice or ice cubes).
- Keep pressing the button until the required quantity is in the glass.

Dispensing water



Note

The water from the water dispenser is cooled to a palatable temperature. If you would like the water colder, place ice cubes in the glass before dispensing the water.

Note

When dispensing fairly large amounts of water, the dispensed water may become warmer.

Dispensing ice



Disconnecting the ice maker

If ice cubes are not to be dispensed for longer than 1 week (e.g. holiday), temporarily disconnect the ice cube maker to prevent the ice cubes from freezing together.

To disconnect the ice maker:

1. Remove the ice cube container.
2. Keep pressing the “options” button, until the [IWD off] function is marked with an arrow.
3. Deactivate by pressing the setting button - (function is no longer framed).
4. Empty and clean ice cube container. Re-attach the ice cube container. Ensure that the ice cube container engages with the support.

Switching on the ice cube maker again:

1. Keep pressing the “options” button, until the [IWD off] function is marked with an arrow.
2. Activate by pressing the setting button + (function is framed).

Water filter

⚠ Warning

Do not use the appliance in places where the water quality is risky or not sufficiently known about without suitable disinfection, before and after filtering.

A filter cartridge for filtering particles can be obtained from customer service or a specialist dealer.

⚠ Caution

- After installing a new filter, always discard the ice produced within the first 24 hours after switching on the ice maker.
- If the ice has not been used for a prolonged period, pour all ice cubes out of the container and also discard the ice produced within the next 24 hours.
- If the appliance or the ice has not been used actively for several weeks or months or if the ice cubes have an unpleasant taste or odor, change the water filter.

- Air trapped in the system may cause water to escape and the filter cartridge to be ejected. Caution when removing.
- The filter must be changed at least every 6 months.

Important information concerning the water filter

- After use, the water system is subject to low pressure. Be careful when removing the filter!
- Rinse the water system through if the appliance has not been used for a long period, or if the water tastes or smells unpleasant. In addition to this, draw water from the water dispenser for several minutes. If the unpleasant taste or smell persists exchange the filter.

Exchanging the filter cartridge

After 6 months you are prompted via the [filter change] display message to change the filter cartridge (see chapter “Special functions”).

Take out the filter cartridge as follows:

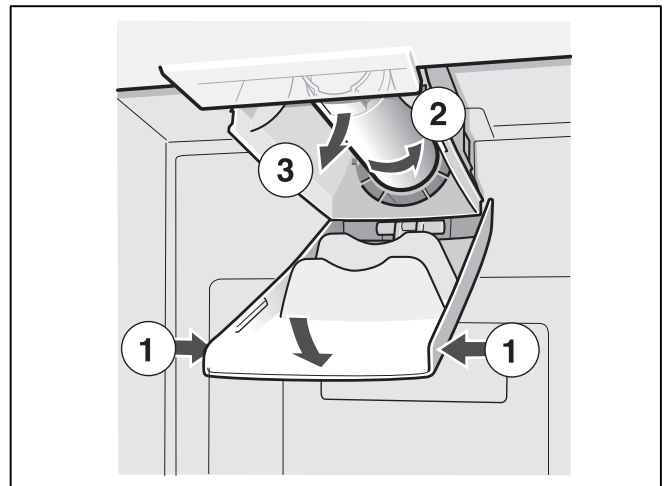

- Insert new filter cartridge.
- Draw a few litres of water from the water dispenser. Doing this removes air from the water system.
- Pour water out of the used filter cartridge. The filter cartridge can be disposed of in the household rubbish.

Specification and performance data sheet

For filter model: 9000 225 170

Using replacement cartridge: 9000 077 104

The model was tested by NSF International with reference to ANSI/NSF Standards 42 & 53 and certified for a reduction in the substances cited below.

The concentration of the indicated substances which are dissolved in water and penetrate the system was reduced to a value below or equal to the permitted limit value in accordance with ANSI/NSF 42 and 53 for water discharged out of the appliance.

Note

Even though the tests were conducted under standard laboratory conditions, the actual performance may deviate from these tests.



The system was tested and certified on model 9000 225 170 by NSF International with reference to ANSI/NSF Standard 53 for a reduction in cysts and turbidity, as well as with reference to ANSI/NSF Standard 42 for a reduction in the taste and odour of chlorine.

Nominal particle class: I

Nominal service life: 2.800 litres

Substance	Average in inflow	Inflow concentration	Waste water concentration	Average reduction as %	Max. permitted concentration in waste water	Max. waste water	Min. reduction as %	NSF test
Cysts *	166.500	Min. 50.000/l	1	99.99	99.95	1	99.99	511077-03
Turbidity	10.7	11 x 1 NTU	0.3 l	97.10	0.5 NTU	0.49	95.42	511078-03
Particle class I Particle size > 0.5 to < 1.0 µm	5.700.000	At least 10.000 particles/ml	30.583	99.52	> 85%	69.000	98.9	511079-03
Taste of chlorine and turbidity	1.9	2.0 mg/l + -10%	0.05	97.3	> 50%	0.06	96.84	511081-03

* Based on the use of Cryptosporium parvum oocysts.

Application guidelines / Water supply parameters:

Water pressure	207 - 827 kPa
Water temperature *	0.6 °C - 38 °C
Flow rate	2.83 l/min.

- The system is to be installed and operated according to the guidelines recommended by the manufacturer.
- The filter is to be changed every 6-9 months.
- Rinse new filter thoroughly for 5 minutes.
- More detailed information can be found on the warranty card.

Without appropriate disinfection before and after connecting it to the system, this product should NOT be used if the water is microbiologically contaminated or if the quality has not been ascertained. A system certified for cyst reduction should be used for disinfected water which possibly contains filterable cysts.

A one-year warranty is issued for the entire system (except disposable cartridge). With reference to disposable cartridges a warranty is issued for material and processing faults only. As the service life of disposable cartridges depends on the local water conditions, no warranty is issued for them.

More detailed information on the prices of spare parts is available from your appliance dealer or parts salesman on site.

Manufactured by:

3 M Material Technology (Guangzhou) Ltd.
9 Nanxiang Er road, Science City,
Guangzhou, 510663, P.R. China

Bar compartment

(not all models)

To remove drinks from the refrigerator compartment, it is not necessary to open the door.

Loading the bar compartment

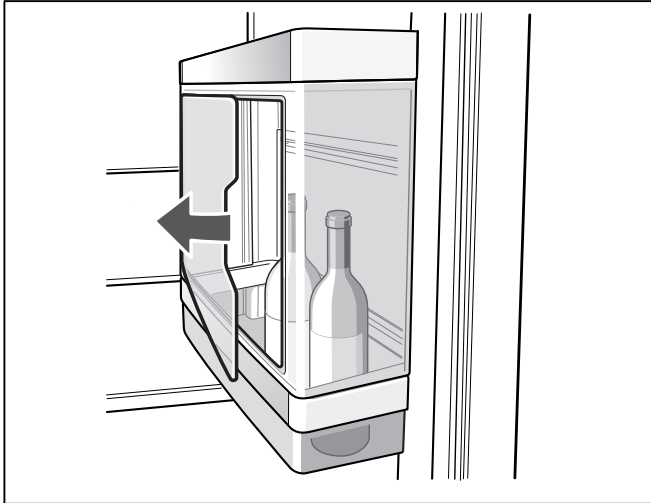

Taking out drinks

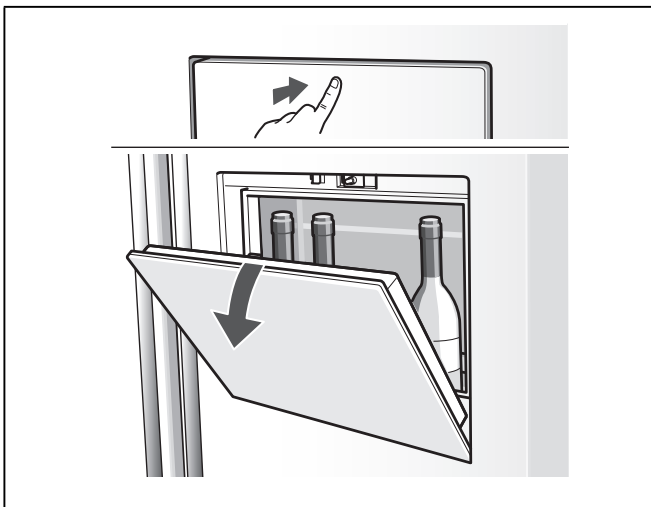

Note

Maximum load: 5 kg

Features of the freezer compartment

(not all models)

Freezer calendar



To prevent the quality of the frozen food from deteriorating, do not exceed the storage duration. The storage period depends on the type of produce. The figures next to the symbols indicate the permitted storage period of the produce in months. In the case of commercially available frozen food observe the date of manufacture or use-by date.

Ice block

If a power failure or malfunction occurs, the ice blocks can be used to slow down the thawing process. The longest storage time is obtained by placing the ice pack on the food in the top compartment.

The ice blocks can also be used to cool food temporarily, e. g. in a cold bag.

Interior fittings of refrigerator compartment

Vegetable container with humidity filter

The vegetable container is covered by a special filter which optimises retention of the air humidity in the storage compartment. This ensures the ideal storage climate for fresh fruit, lettuce, vegetables, herbs and mushrooms.

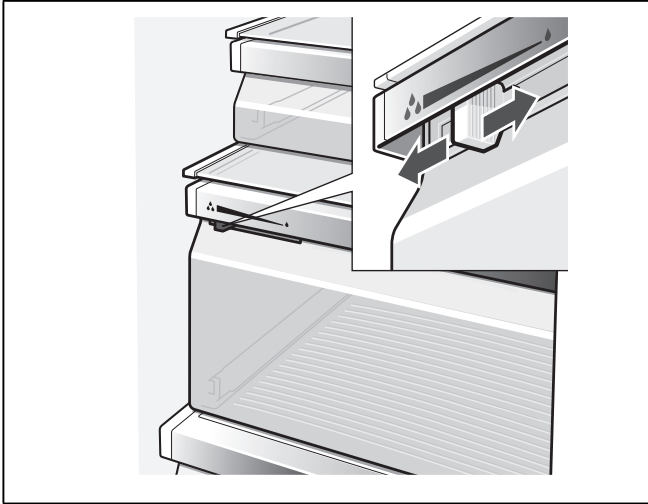

The air humidity in the vegetable container can be regulated according to the quantity stored:

Smaller quantities of food –
slide the regulator to the right.

Large quantities of food –
slide the regulator to the left.

A high air humidity keeps leafy vegetables fresh for longer. Vegetables and fruit should be stored at a slightly lower air humidity.

Note

If the air humidity is too high, drips may form and cause decay.

Variable interior design

You can vary the shelves inside the appliance and the door shelves as required.

- Pull shelf forwards, lower and swing out to the side.

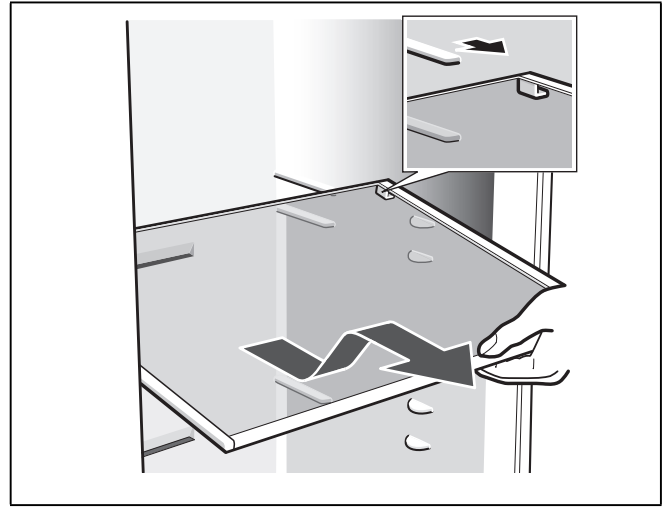

- Lift the door shelf and remove.

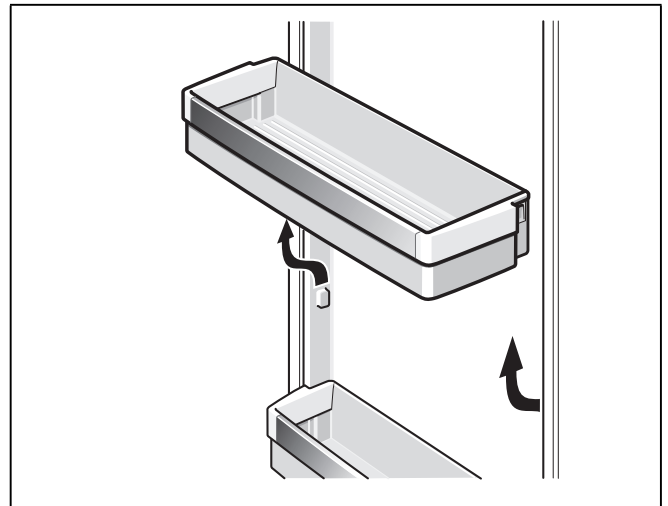

Special features

(not all models)

Adjustable glass shelf "easy Lift"

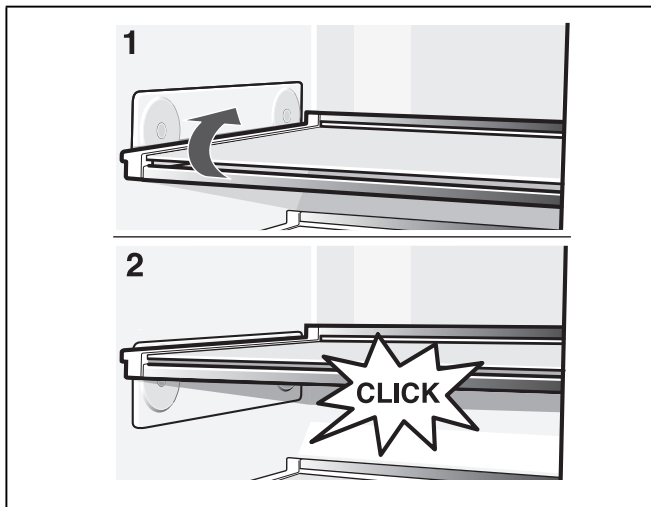

The height of the shelf can be adjusted without taking it out. Take food off the shelf beforehand.

The max. shelf load: 3 kg

Adjustable "easy Lift" door shelf

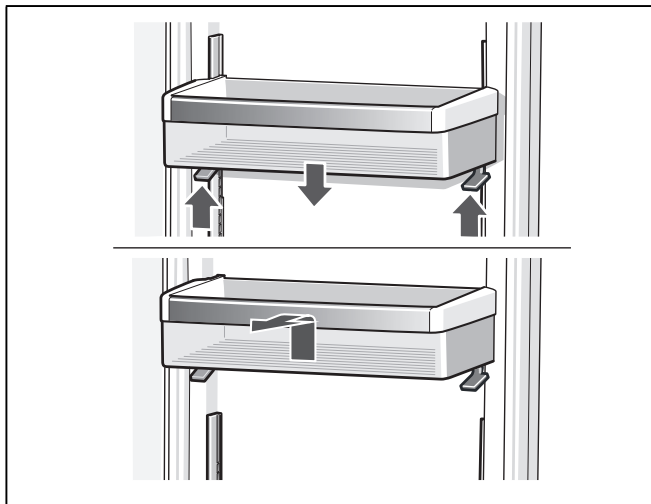

Press lever upwards to move the door shelf down.

The shelf can be moved up without pressing the levers.

To take out, lift the door shelf and take out.

Switching off and disconnecting the appliance

Switching the appliance off

Press the On/Off button.

Pull out the mains plug.

Disconnecting the appliance

If you do not use the appliance for a prolonged period:

1. Before switching off, it is most important that you switch the water supply to the appliance off for a few hours.
2. Take all food out of the appliance.
3. Switch the appliance off.
4. Pull out mains plug or switch off fuse.
5. Empty and clean the ice cube container (see chapter Cleaning the appliance).
6. Clean the appliance interior (see chapter Cleaning the appliance).
7. Leave the appliance doors open to prevent odours from forming.

Defrosting

Freezer compartment

The fully automatic NoFrost system ensures that the freezer compartment remains free of ice. Defrosting is no longer required.

Refrigerator compartment

Defrosting is actuated automatically.

The condensation runs through the drainage hole into an evaporation pan on the rear of the appliance.

Cleaning the appliance

⚠ Warning

Never clean the appliance with a steam cleaner!

⚠ Caution

Do not use abrasive, chloride or acidic cleaning agents or solvents.

⚠ Caution

Do not use scouring or abrasive sponges. The metallic surfaces could corrode.

⚠ Caution

Never clean shelves and containers in the dishwasher. The parts may become deformed!

Proceed as follows:

1. Before cleaning: Switch off the appliance.
2. Pull out mains plug or switch off fuse.
3. Take out the frozen food and store in a cool location. Place the ice pack (if enclosed) on the food.
4. Wait until the layer of frost has thawed.
5. Clean the appliance with a soft cloth, lukewarm water and a little pH neutral washing-up liquid. The rinsing water must not run into the light.
6. Wipe the door seal with clear water only and then wipe dry thoroughly.
7. After cleaning reconnect and switch the appliance back on.
8. Put the frozen food back into the appliance.

Interior fittings

To clean the equipment, all variable parts of the appliance can be taken out (see chapter Variable interior design).

Note

To take out and clean the containers, open the doors fully beyond 90°.

Removing the container

Pull out container all the way, lift to detach it from the holder and take out.

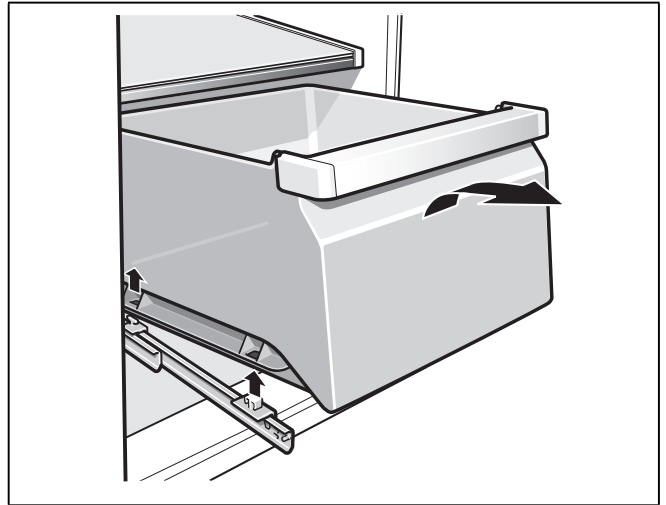

To insert the container, place on the telescopic rails and push into the appliance. Attach the container by pressing it down.

Removing the humidity filter

Take out the vegetable container first. Then, pull out the humidity filter.

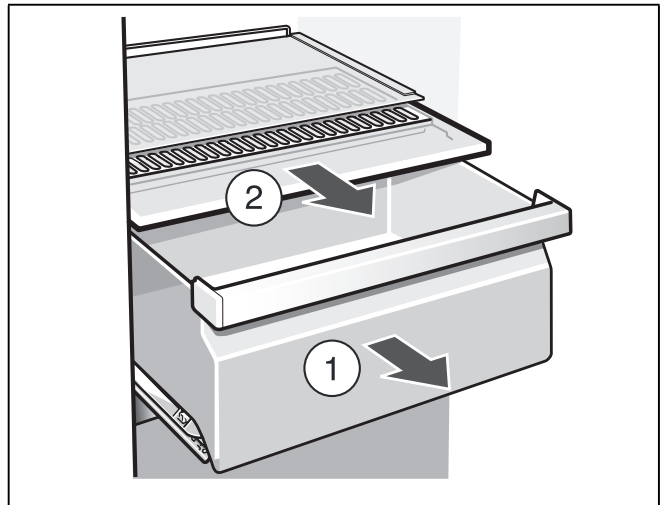

Lift off the filter cover, take out the filter, clean in lukewarm water, leave to dry and re-assemble.

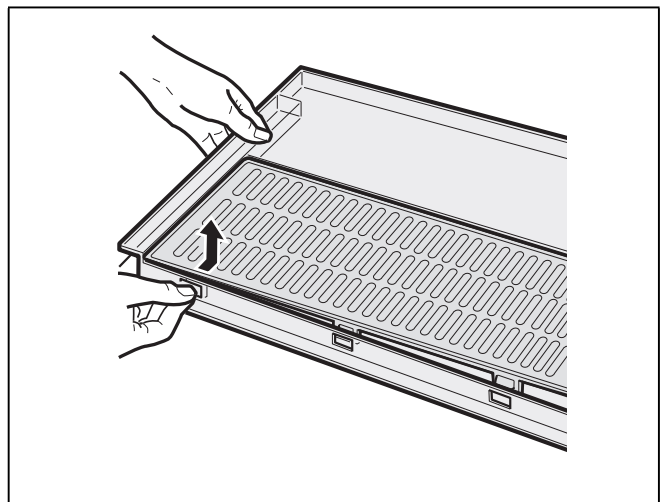

Cleaning the water collection tray

Spilled water collects in the water collecting tray. To empty and clean, remove the filter. Wipe out water collecting tray with a sponge or absorbent cloth.

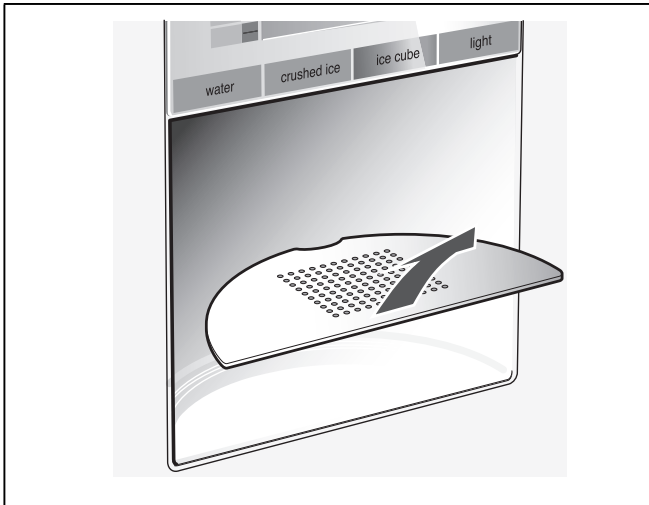

Cleaning the ice cube container

If ice cubes have not been dispensed for a prolonged period, they will shrink, have a stale taste and stick together.

Pull out the container, empty and clean with lukewarm water.

⚠ Caution

A full ice cube container is heavy!

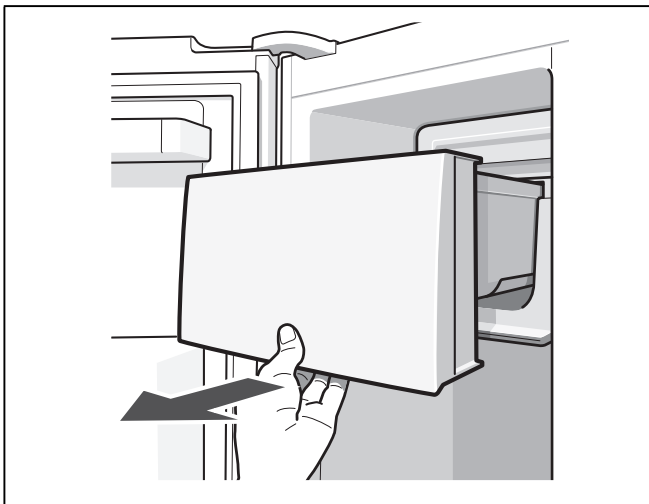

After cleaning, dry the container and feed screw thoroughly to prevent the new ice cubes from sticking.

Inserting the ice cube container

Push the ice cube container all the way back onto the supports until it locks into position. Ice cube production continues.

Note

If the container cannot be pushed all the way back, twist the screw conveyor in the container or remove frozen ice cubes from the area of the shelf.

Light

(not all models)

Light (LED)

Your appliance features a maintenance-free LED light. These lights may be repaired by customer service or authorised technicians only.

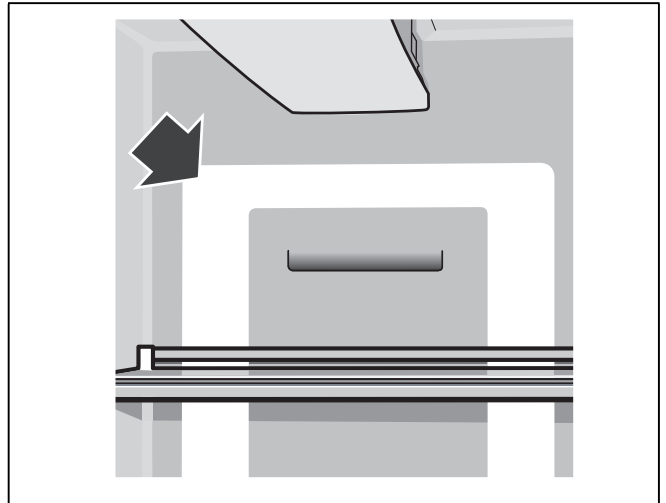

Change LED bulb in cooling compartment

1. Switch off the appliance with the On/Off button.
2. Pull out the mains plug or switch off the fuse.
3. Remove the cover strip.

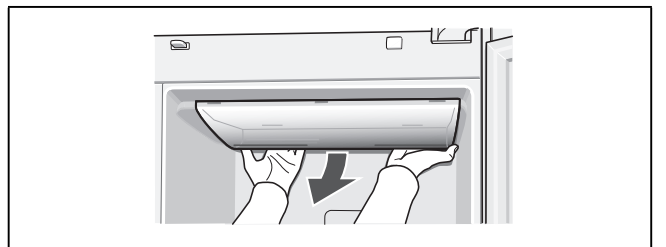

4. Change the LED bulb (LED replacement bulb: 220-240 V AC, E14 bulb holder, see defective bulb for wattage).
5. Reattach the cover strip.

Tips for saving energy

- Install the appliance in a dry, well ventilated room!
The appliance should not be installed in direct sunlight or near a heat source (e.g. radiator, cooker).
If required, use an insulating plate.
- Do not block the ventilation openings in the appliance.
- Allow warm food and drinks to cool down before placing in the appliance.
- Thaw frozen food in the refrigerator compartment and use the low temperature of the frozen food to cool refrigerated food.
- Open the appliance as briefly as possible.
- Ensure that the freezer compartment door is always closed properly.
- If available:
Fit wall spacers to obtain the indicated energy rating of the appliance (see “Installing the appliance”, section “Ventilation”). A reduced wall gap will not restrict the function of the appliance. The energy rating may then increase slightly.
- The arrangement of the fittings does not affect the energy rating of the appliance.

Operating noises

Quite normal noises

Droning

Motors are running (e.g. refrigerating units, fan).

Bubbling, humming or gurgling noises

Refrigerant is flowing through the tubing or water is flowing into the ice maker.

Clicking

Motor, switches or solenoid valves are switching on/off.

Rumbling

Ready ice cubes from the ice maker are falling into the ice cube container.

Preventing noises

The appliance is not level

Please align the appliance with a spirit level. Use the height-adjustable feet or place packing underneath them.

The appliance is not free-standing

Please move the appliance away from adjacent units or appliances.

Containers or storage areas wobble or stick

Please check the removable parts and re-insert them correctly if required.

Bottles or receptacles are touching each other

Move the bottles or receptacles slightly away from each other.

Eliminating minor faults yourself

Before you call customer service:

Please check whether you can eliminate the fault yourself based on the following information.

Run an appliance self-test (see chapter "Appliance self-test").

Customer service will charge you for advice even if the appliance is still under guarantee!

Fault	Possible cause	Remedial action
Temperature differs greatly from the set value.		In some cases it is adequate to switch off the appliance for 5 minutes. If the temperature is too high wait a few hours and check whether the temperature has approached the set value. If the temperature is too low check the temperature again the next day.
Displays do not illuminate.	Power failure; the fuse has been switched off; the mains plug has not been inserted properly.	Connect mains plug. Check whether the power is on, check the fuses.
Display indicates "E..".	Electronics have detected a fault.	Call customer service.
Warning signal sounds and the temperature display on the freezer compartment flashes. The freezer compartment is too warm! Frozen food is at risk!		To switch off the warning signal, press the "alarm/lock" button. The display stops flashing. The warmest temperature reached in the freezer compartment is indicated on the temperature display for 10 seconds.
	Freezer compartment door is open.	Close the door.
	Ventilation openings have been covered.	Remove obstacles.
	Too much food was placed in the freezer compartment at once.	Do not exceed max. freezing capacity.
		Note Frozen food which has started thawing or which has thawed can be refrozen if meat and fish were above +3 °C for not more than one day or other frozen food for not more than three days.
The light does not work.	Light switch is jammed.	Check whether the light switch can move.
	The light is defective.	(See chapter "Light".)
Appliance has no refrigeration capacity.	Appliance has been switched off.	Press the On/Off button.
The light does not work.	Power failure.	Check whether the power is on.
The display does not illuminate.	The fuse has been switched off.	Check the fuse.
	The mains plug has not been inserted properly.	Check whether the mains plug is secure.
The refrigerating unit is switching on more frequently and for longer.	Appliance opened frequently.	Do not open the appliance unnecessarily.
	The ventilation openings have been covered.	Remove obstacles.
	Large quantities of fresh food are being frozen.	Do not exceed max. freezing capacity.

Water and ice dispenser

Fault	Possible cause	Remedial action
Despite prolonged operating time, ice cubes are not being dispensed.	Tap turned off.	Turn on tap.
	Water supply is interrupted. Water pressure too low.	Inform plumber.
	Ice and water dispenser is switched off. "IWD off" is lit on the display panel.	Switch on ice and water dispenser (see "Switching on and off the ice and water dispenser").
	Freezer compartment too warm.	Lower temperature in the freezer compartment (see chapter "Setting the temperature").
Ice cubes are in the ice cube container but are not being dispensed.	Ice cubes are frozen together.	Remove and empty the ice cube container.
Ice cubes are jammed in the outlet of the ice cube container or in the ice crusher.		Remove the ice cube container and rotate the screw conveyor by hand. Loosen any jammed chunks of ice with a wooden chopstick.
Ice cubes are watery. Ice cubes have melted.		Remove the ice cube maker, empty and rub dry.
	Freezer compartment door is open.	Close the door.
	Power failure.	Check whether the power is on.
Water dispenser is not functioning.	Tap turned off.	Turn on tap.
	Water supply is interrupted. Water pressure too low.	Inform plumber.
The ice maker does not make enough ice or the ice is deformed.	The appliance or ice maker has only just been switched on.	Approx. 24 hours is needed until ice production starts.
	A lot of ice has been taken.	Approx. 24 hours is needed until the ice cube container is filled again.
	Low water pressure.	Connect the appliance to the stipulated water pressure only (see chapter Connecting the appliance, section Water connection).
	The water filter is bunged up or used.	Change the water filter.
	Temperature in the freezer compartment is too warm.	Set temperature slightly colder in the freezer compartment.
Bubbling, gurgling noises in the water line.	Water supply is interrupted or water line is blocked.	<ol style="list-style-type: none"> 1. Check water supply. 2. Check whether the water line is blocked. 3. In some cases it is adequate to switch off the ice and water dispenser briefly (see chapter "Switching on and off the ice and water dispenser").

Appliance self-test

Your appliance features an automatic self-test program which shows you sources of faults which may be repaired by customer service only.

Starting the appliance self-test

1. Switch off the appliance and wait 5 minutes.
2. Switch the appliance on again.
3. Simultaneously press “options” and “select” buttons for 5 seconds.

The self-test programme starts. If “E..” is indicated on the display panel, an error has occurred. If this fault is displayed, inform customer service.

Ending the appliance self-test

Simultaneously press again “options” and “select” buttons for 5 seconds.

Customer service

Your local customer service can be found in the telephone directory or in the customer-service index. Please provide customer service with the appliance product number (E-Nr.) and production number (FD-Nr.).

These specifications can be found on the rating plate.

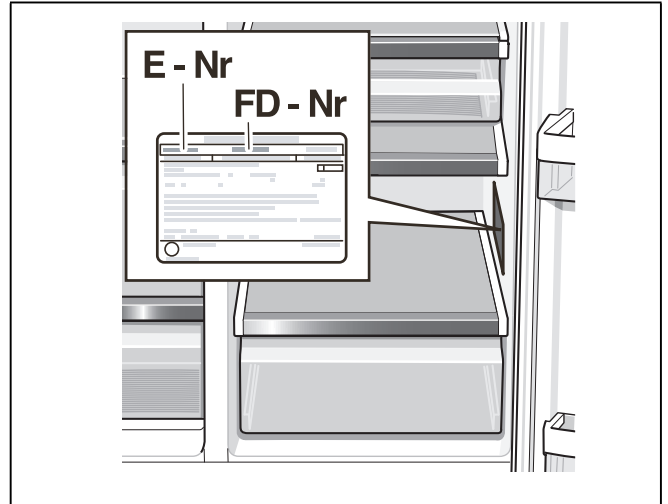

To prevent unnecessary call-outs, please assist customer service by quoting the product and production numbers. This will save you additional costs.

Repair order and advice on faults

Contact information for all countries can be found on the enclosed customer service list.

GB	0344 892 8999	Calls charged at local or mobile rate.
IE	01450 2655	0.03 € per minute at peak. Off peak 0.0088 € per minute.
US	866 447 4363	toll-free

BSH Hausgeräte GmbH
Carl-Wery-Straße 34
81739 München, GERMANY

siemens-home.com

Manufactured by BSH Hausgeräte GmbH under Trademark License of Siemens AG



8001027806 (9510)
en