

EN VDE COVER ASSEMBLY INSTRUCTIONS

This spare part may be assembled by qualified and instructed specialized personnel (electricians) only. The proper function and the safety of the appliance can be affected by an improper repair and even serious threats to life or physical condition may arise. We are not liable for damages caused by the improper use of third persons. For repairs on domestic appliances the approved technical regulations are applied. Any existing additional country-specific requirements and regulations must be observed. In case of doubt please contact our factory own customer service.

Bag contents:

- 4 small screws (Type A)



- 4 large screws (Type B)

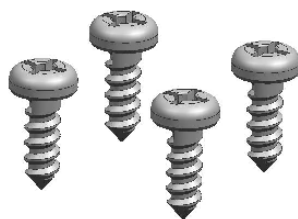

1 Metal plate



General procedure:

Remove wooden worktop: First, get out two screws on the back side, Second, slide the worktop to the rear part and finally up. Washing machine then looks like Figure 1. Until metal plate is totally installed, the plug of the machine must be disconnected.

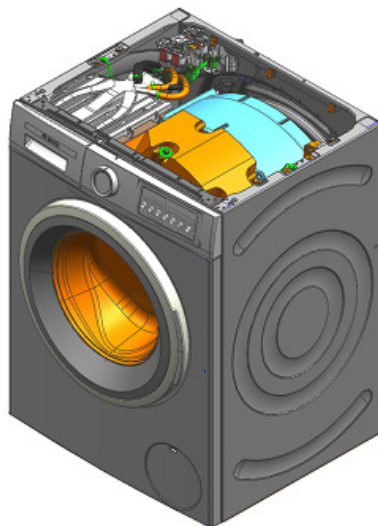
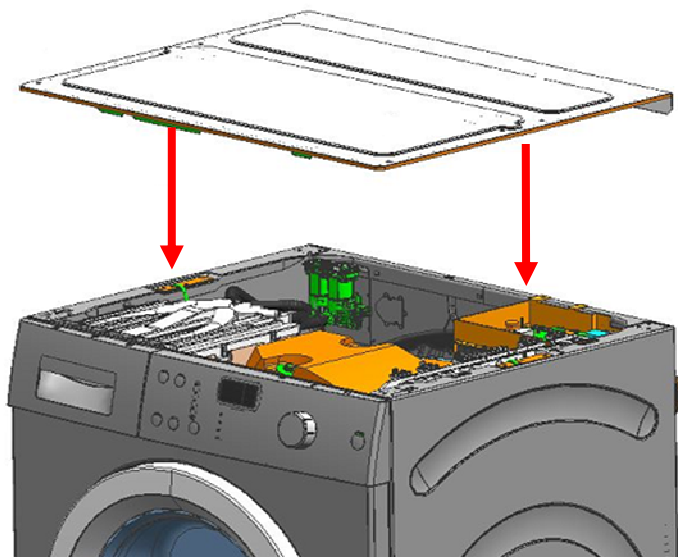
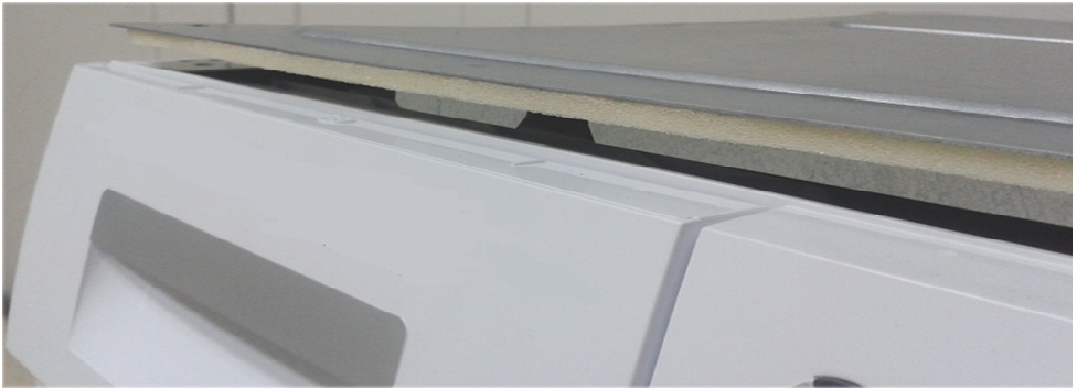

Fig. 1

1. Fit the metal plate onto the washing machine





Adjust the frontal metallic wall behind the control panel

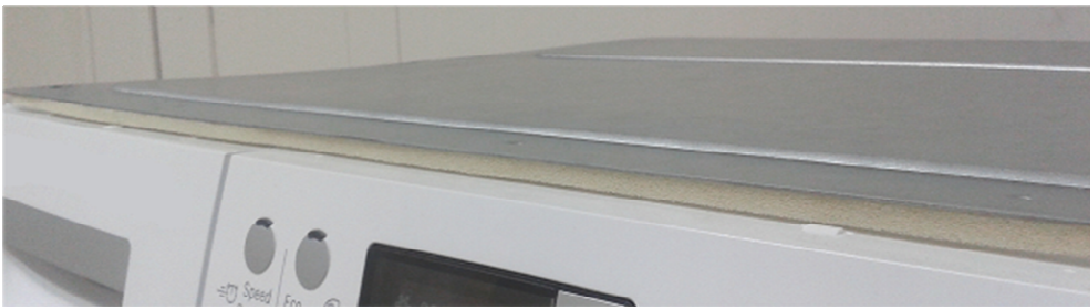

2. Tight two front screws (type A)

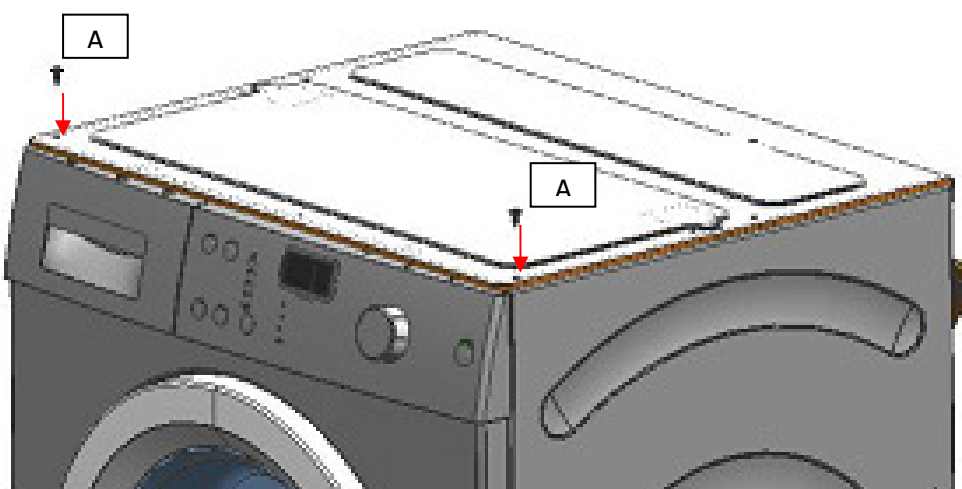

3. Tight two rear screws (type A)

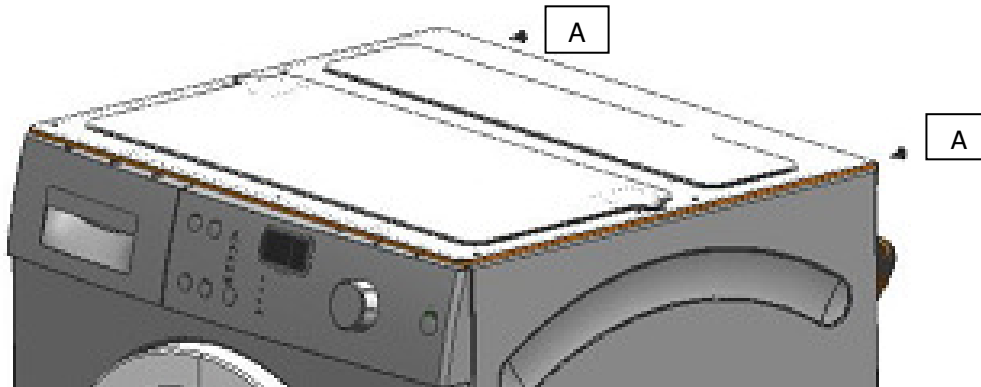

1. Tight four screws (type B) on the lateral area

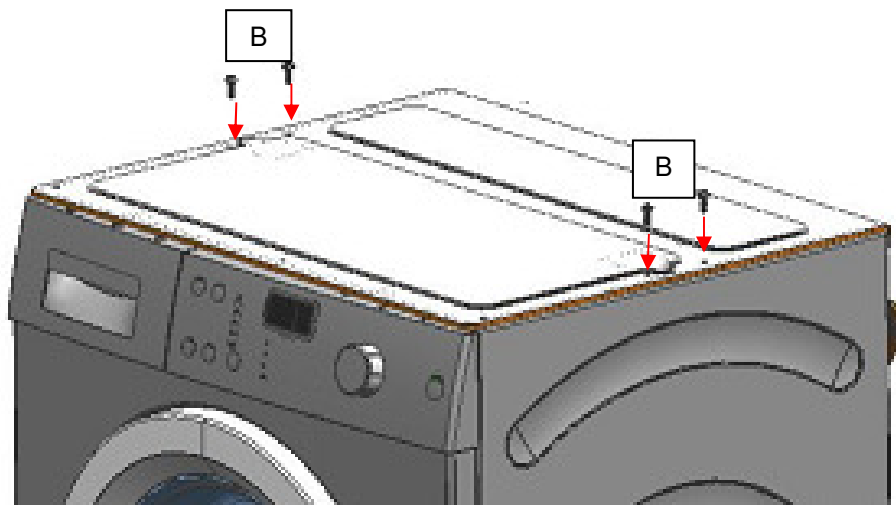

There is a video of this assembly process in the official web page