

studioLine





Fusion of elegance and innovation in your kitchen

Siemens Home Appliances provides the studioLine series for individuals who aspire to elevate their kitchen experience to unprecedented levels of sophistication and excellence. studioLine embodies the pursuit of remarkable design, integrating the latest innovations, and ensuring the ultimate kitchen experience.

Artful minimalism in kitchen elegance

In architecture, lines are the blueprint for structure, guiding how buildings take shape, while symmetry is the secret sauce that interior designers use for a balanced look. Our minimalist design not only enhances your kitchen's aesthetics but also simplifies your experience, ensuring both elegance and efficiency. Even in the smallest details, like our glass door handles only in our new studioLine oven, we prioritize seamless design, aiming to elevate every aspect of your kitchen.





Design elegance

Siemens Home Appliances' studioLine series is a testament to exquisite design, crafted for individuals aspiring to elevate their kitchen experience. This line embodies a pursuit of remarkable aesthetics, ensuring that each appliance harmonizes seamlessly with a modern lifestyle. Meticulous attention to detail and sophisticated design principles define studioLine, catering not just to functionality but also to the visual appeal that integrates effortlessly into contemporary kitchens.



Technological mastery

Beyond its captivating design, studioLine by Siemens champions the forefront of innovation and technology in kitchen appliances. Each product within this series integrates cutting-edge technological advancements, promising an unparalleled culinary experience. From state-of-the-art functionalities to precision engineering, studioLine appliances are meticulously crafted to deliver superior performance, transforming ordinary kitchen tasks into seamless, efficient processes that align with the demands of modern living.

HS958GED1B

Built-in oven with steam function

Step into the future of cooking with the award-winning iQ700 built-in oven. This oven isn't just any oven. It's like having a chef in your kitchen thanks to its powerful steam feature and cool built-in camera. That means delicious, tasty meals and keeping an eye on your food while it cooks. Plus, it's designed to make your kitchen look super sleek and works like a dream.



Flawless and precise results



Individual Browning

Achieves the excellent level of brownness through the camera and AI. The built-in camera continuously captures images, allowing AI to perform background comparisons, ensuring flawless and precise results every time.



fullSteam Plus

Easily create nutritious steam-cooked meals with fullSteam Plus. Connect to tap water for a continuous fresh supply. Try vacuum-sealed sous-vide bags for enhanced flavors.



Camera

Experience convenience with the built-in oven camera. Monitor your food from anywhere, courtesy of this innovative feature.



cookControl Pro

Concerned about overcooking your meals? Our oven's preset programs and sensors handle it. Pick your dish, it suggests automatic settings based on the selected dish and cooking type, offering suggested configurations that can be easily used or adjusted as needed.



TFT-Touchdisplay Pro

Use your oven easily and comfortably with its huge screen and user-friendly menu, soft touch navigation and high-contrast color screen.

HB978GNB1B

Built-in oven

Experience culinary excellence with the award-winning iQ700 built-in oven. A fusion of style and functionality, this oven redefines modern cooking. Alongside its standout features such as automatic cooking, seamless connectivity, and advanced baking and cooking sensors, this appliance boasts effortless cleanability.



cookControl Pro

Concerned about overcooking your meals? Our oven's preset programs and sensors handle it. Pick your dish, it suggests automatic settings based on the selected dish and cooking type, offering suggested configurations that can be easily used or adjusted as needed.

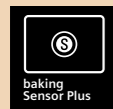

bakingSensor Plus

No more worries about excellent baking! The bakingSensor Plus measures the moisture level in the oven during the fully automatic baking process, guaranteeing excellent results.



humidClean Plus

Ready for fast cleaning of your oven? Remove the dirt easily by vaporizing soapy water with humidClean Plus.

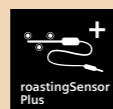

roastingSensor Plus

Worried about burning your meat? Measure your meat temperature for highest accuracy with roastingSensor Plus.

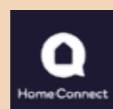

Home Connect

Control remotely as you wish and access next level connectivity. Manage cooking programs, settings, and get updates on your oven's status from anywhere.

Every dish as
it's meant to be

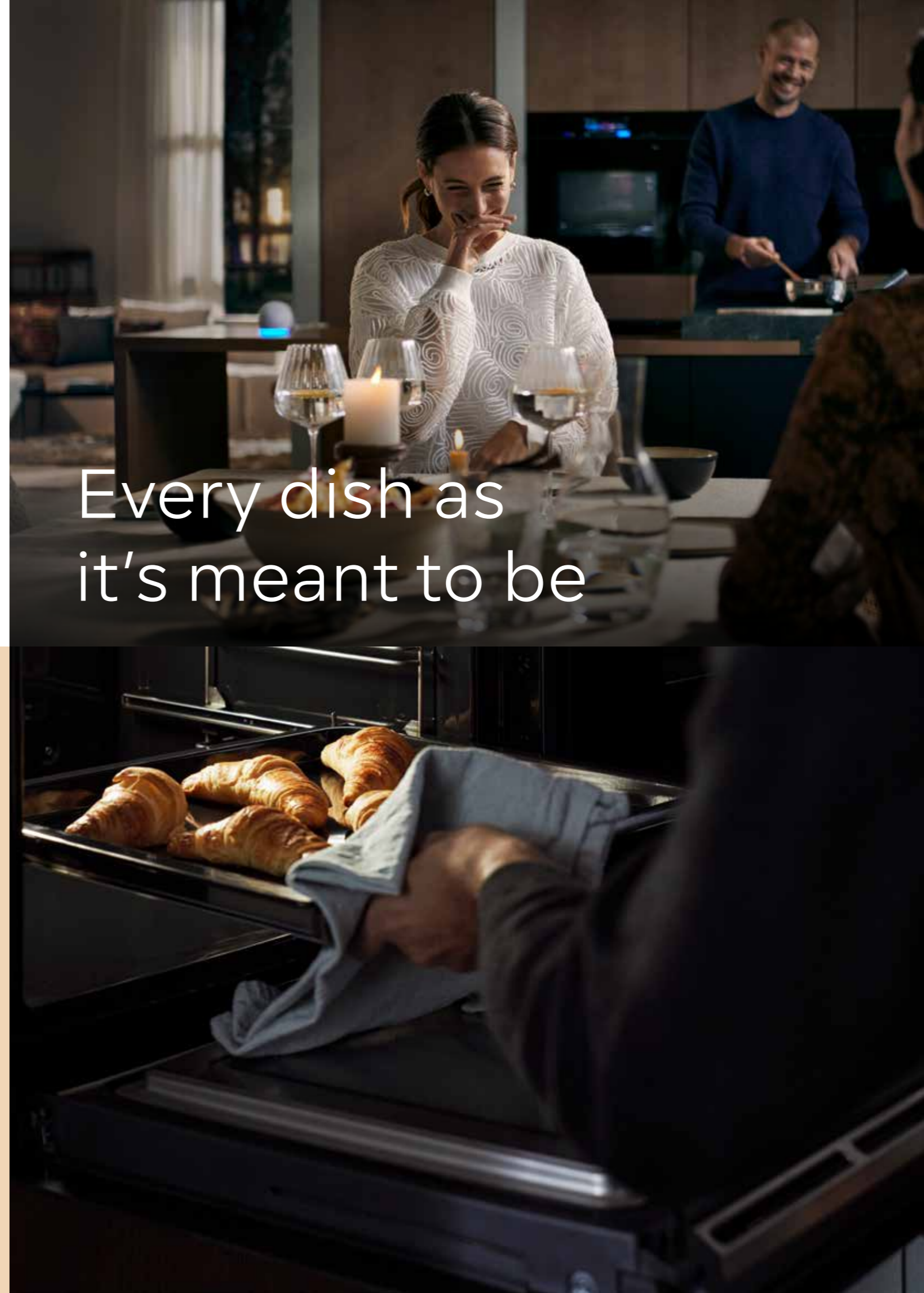

HS958GDD1

Combi-steam oven

Elevate kitchen with the award-winning combi-steam oven, honored with the iF 2023 and German Design 2023 awards. Redefining culinary innovation, this oven seamlessly merges style with functionality. With its intuitive controls and versatile steam-convection cooking, it's more than an appliance; it's a symbol of sophistication and precision in modern cooking. Experience excellence in every dish with the combi-steam Oven.



Automatic and smart



cookControl Pro

Concerned about overcooking your meals? Our oven's preset programs and sensors handle it. Pick your dish, It suggests automatic settings based on the selected dish and cooking type, offering suggested configurations that can be easily used or adjusted as needed.



fullSteam Plus

Easily create nutritious steam-cooked meals with fullSteam Plus. Connect to tap water for a continuous fresh supply. Try vacuum-sealed sous-vide bags for enhanced flavors.



Home Connect

Control remotely as you wish and access next level connectivity. Manage cooking programs, settings, and get updates on your oven's status from anywhere.

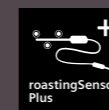
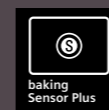

bakingSensor Plus & roastingSensor Plus

With the innovative bakingSensor and roastingSensor, achieving instead of excellence.

LR18HLT65

Ceiling cooker hood

The iQ700 ceiling cooker hood harmonizes cutting-edge design with unparalleled performance. Its distinctive design ensures ergonomic use, featuring adjustable settings for personalized functionality. Seamlessly integrating modern convenience, this hood is equipped with voice control, standing ready to assist in your kitchen tasks.



Elevate your cooking experience

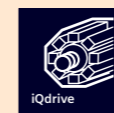

iQdrive Motor

Experience top-notch performance with our silent and efficient motor, effectively eliminating steam and odors to elevate your cooking experience to its fullest delight.



varioLift

The VarioLift design hoods offer effortless usability, allowing for easy attachment and removal whenever necessary. This exceptional feature grants remarkable flexibility without any compromise on performance.

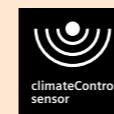

climateControl system with cookConnect

climateControl seamlessly detects and delivers optimal performance. With cookConnect, the system effortlessly links with your stove, enabling the hood to autonomously adjust according to the stove's settings and operation, ensuring an ideal environment.



Home Connect

Control remotely as you wish and access next level connectivity. Effortlessly oversee cooking programs, adjust settings, and receive real-time updates on your oven's status from any location.

LC97FVW69I

Wall-mounted cooker hood

The iQ700 wall-mounted cooker hood redefines kitchen sophistication and performance. With its sleek design and powerful functionalities, it effortlessly elevates your cooking experience. The adjustable features ensure personalized usage, while its contemporary look seamlessly integrates into your kitchen's aesthetic. Voice control adds an extra layer of convenience, making it an indispensable tool for culinary enthusiasts seeking both style and efficiency in their cooking space.

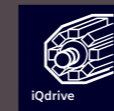

iQdrive Motor

Experience top-notch performance with our silent and efficient motor, effectively eliminating steam and odors to elevate your cooking experience to its fullest delight

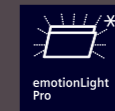

emotionLight Pro

Your hood effortlessly mirrors your mood each day. With the Home Connect App, make your kitchen match fit into your day, allowing you to pick the excellent one that resonates with your current feelings.

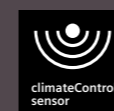

climateControl system with cookConnect

climateControl seamlessly detects and delivers optimal performance. With cookConnect, the system effortlessly links with your stove, enabling the hood to autonomously adjust according to the stove's settings and operation, ensuring an ideal environment.



Home Connect

Control remotely as you wish and access next level connectivity. Effortlessly oversee cooking programs, adjust settings, and receive real-time updates on your oven's status from any location.



LC91KWW61I

Wall-mounted cooker hood

The iQ700 wall-mounted cooker hood represents a pinnacle of both style and functionality in your kitchen. Its elegant design merges seamlessly with top-notch performance, promising an elevated cooking atmosphere. Tailor your experience with its adjustable features, ensuring optimal use for your culinary needs. Even when not in action, its modern aesthetic becomes an eye-catching addition to your kitchen space. And with voice control, it stands ready to assist, making cooking a more efficient and enjoyable affair.



Effective elimination
of steam and odors

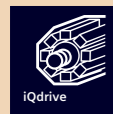

iQdrive Motor

Experience top-notch performance with our silent and efficient motor, effectively eliminating steam and odors to elevate your cooking experience to its fullest delight

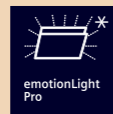

emotionLight Pro

Your hood effortlessly mirrors your mood each day. With the Home Connect App, you're spoiled for choice with a myriad of colors, allowing you to pick the excellent one that resonates with your current feelings.



climateControl system with cookConnect

climateControl seamlessly detects and delivers optimal performance. With cookConnect, the system effortlessly links with your stove, enabling the hood to autonomously adjust according to the stove's settings and operation, ensuring an ideal environment.

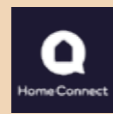

Home Connect

Control remotely as you wish and access next level connectivity. Effortlessly oversee cooking programs, adjust settings, and receive real-time updates on your oven's status from any location.



EX677NYV6E

Induction hob

Siemens' iQ700 Induction Hob received the 2023 Red Dot and 2023 iF awards for its exceptional design and innovative features. With a sleek appearance that complements modern kitchens, this hob boasts intuitive controls, precise temperature settings, and energy efficiency. Its recognition by both the Red Dot and iF awards highlight its excellence in both design and functionality.



Seamless adaptation to your lifestyle

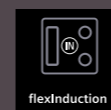

flexInduction Plus

A hob that adapts to your lifestyle. Adjust cooking zones according to your cookware with up to 30cm expansion in diameter.

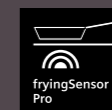

fryingSensor Plus

Excellent frying results, over and over again. Alerts you when the pan reaches the correct temperature and maintains the same heat level as you cook.



Blue dual lightSlider

Allows you to select cooking zones on both sides of your hob. Just touch and swipe to control your hob.



powerMove Plus

For the perfect versatility in cooking, powerMove Plus divides your cooktop into three distinct heating zones. Whether you're roasting at high temperatures in the rear or keeping dishes warm at the front, each zone activates when cookware is placed upon it.



Home Connect

Home Connect, seamlessly integrates intelligent software and a user-friendly app, they lighten your workload and open up new possibilities for unprecedented comfort and convenience.





Measurements in mm

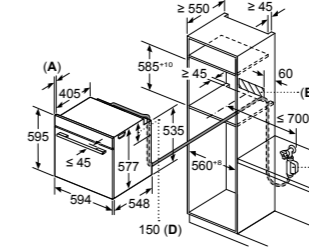

- A: 19.5 mm
- B: Space for appliance connection 320 x 115 mm
- C: Water connection for supply hose must always be accessible
- D: Water connection must be 150 mm lower than upper edge of appliance
- E: Measured from centre of appliance

Measurements in mm

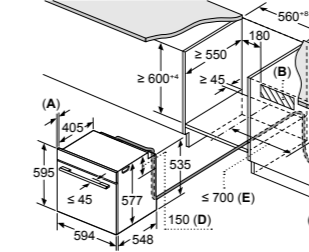

- A: 19.5 mm
- B: Space for appliance connection 320 x 115 mm
- C: Water connection for supply hose must always be accessible
- D: Water connection must be 150 mm lower than upper edge of appliance
- E: Measured from centre of appliance

Installing two appliances on top of each other
Air exchange

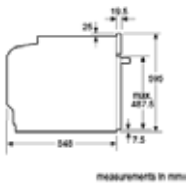
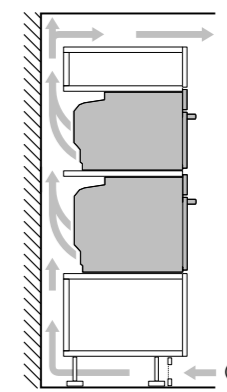

A: Air inlet $\geq 200 \text{ cm}^2$

Technical Details of studioLine Products

Short Description	60 cm Oven with Steam
Key Highlights	<ul style="list-style-type: none"> • Oven capacity: 71 Litres • 160x70mm TFT-Touchdisplay Pro-color and graphics display with direct touch function • 4D Hot Air • Full Steam functions • roastingSensor Plus • bakingSensor Plus
Design & Innovation features	<ul style="list-style-type: none"> • Combi-steam oven with 15: heating methods: 4D hot air, hot air eco, hot air grilling, conventional heat, conventional heat ECO, full width grill, half width grill, pizza setting, coolStart, bottom heat, intensive heat, slow cooking, drying, keep warm setting, plate warming • Additional heating methods with steam: Steamplus, reheating, proving, defrosting, sous-vide • Full Glass Inner door • Integrated glass sturdy handle • Integral cooling fan • Water inlet system: Fixed connection • varioClip rails Plus, full extension, with Stop function • softMove door • 5 shelf levels • Automatic rapid heat function • Sabbath function • Oven assistant with voice control, supports Alexa, Fitbit, Google assist mini, IFTTT
Cleaning Features	<ul style="list-style-type: none"> • Drying function • ecoClean Plus function for back, ceiling & side liners • descaling programme
Safety & Quality features	<ul style="list-style-type: none"> • Residual heat indicator • Childproof lock function • Automatic safety switch off
Dimensions	<ul style="list-style-type: none"> • Appliance dimensions (HxWxD): 59.5cm x 59.4cm x 54.8cm • Cutout dimensions (HxWxD): 58.5cm - 59.5cm x 56cm - 56.8cm x 55cm
Technical Information	<ul style="list-style-type: none"> • Connecting cable: 120cm • Total connected load: 3.45 kW • Heating temperature: 30°C - 250°C

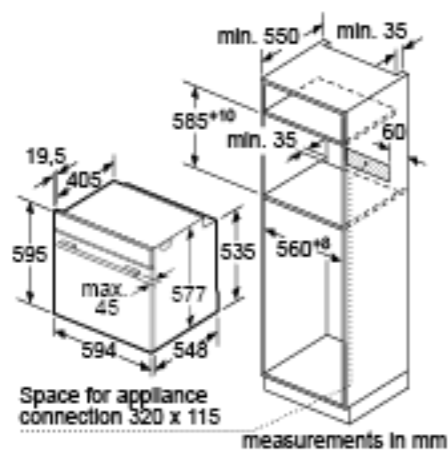

Installing two appliances on top of each other
Air exchange

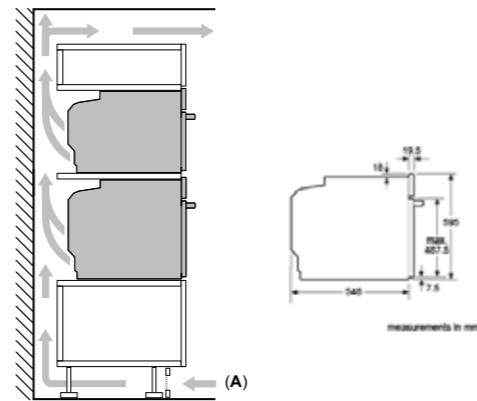

Short Description	60 cm Oven
Key Highlights	<ul style="list-style-type: none"> Oven capacity: 71 Litres 160x70mm -TFT-color and graphics display with direct touch function 4D Hot Air display with direct touch function coolStart function Oven LED Interior Light Telescopic rails
Design & Innovation features	<p>Type of oven / heating system:</p> <ul style="list-style-type: none"> Oven with 13 heating methods: 4D hotair, Hotair eco, conventional heat, conventional heat ECO, hotAir grilling, full width grill, half width grill, pizza setting, coolStart, bottom heat, slow cooking, plate warming setting, keep warm setting, plate warming Full Glass Inner door Integral cooling fan softMove door Automatic rapid heat function Sabbath function cookControl Plus
Cleaning Features	<ul style="list-style-type: none"> Automatic System for Effortless Cleaning- activeClean humidClean Plus
Safety & Quality features	<ul style="list-style-type: none"> Residual heat indicator Childproof lock function Automatic safety switch off
Dimensions	<ul style="list-style-type: none"> Appliance dimensions (HxWxD): 59.5cm x 59.4cm x 54.8cm Cutout dimensions (HxWxD): 58.5cm - 59.5cm x 56cm - 56.8cm x 55cm
Technical Information	<ul style="list-style-type: none"> Connecting cable: 120cm Total connected load: 3.6 kW Heating temperature: 30°C - 300°C



Measurements in mm

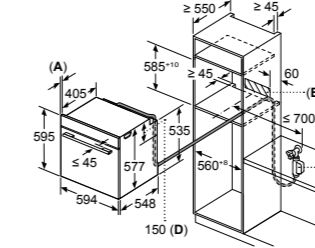

- A: 19.5 mm
- B: Space for appliance connection 320 x 115 mm
- C: Water connection for supply hose must always be accessible
- D: Water connection must be 150 mm lower than upper edge of appliance
- E: Measured from centre of appliance

Installing two appliances on top of each other
Air exchange

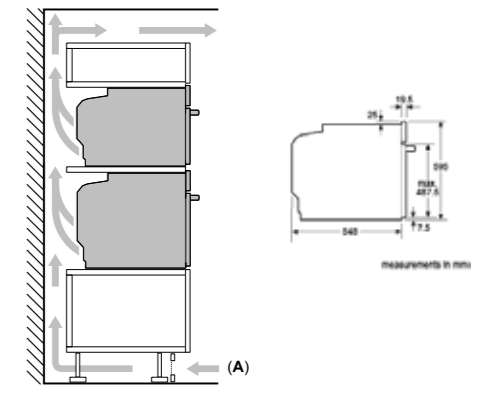

Measurements in mm

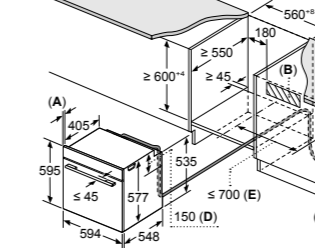

- A: 19.5 mm
- B: Space for appliance connection 320 x 115 mm
- C: Water connection for supply hose must always be accessible
- D: Water connection must be 150 mm lower than upper edge of appliance
- E: Measured from centre of appliance

Short Description	60 cm Oven with camera
Key Highlights	<ul style="list-style-type: none"> Oven capacity: 71 Litres Individual Browning with camera 160x70mm TFT-Touchdisplay Pro-color and graphics display with direct touch function 4D Hot Air Full Steam Functions roastingSensor Plus bakingSensor Plus cookControl Pro
Design & Innovation features	<ul style="list-style-type: none"> Combi-steam oven with 15: Heating methods: 4D hot air, hot air eco, hot air grilling, conventional heat, conventional heat ECO, full width grill, half width grill, pizza setting, coolStart, bottom heat, intensive heat, slow cooking, drying, keep warm setting, plate warming Additional heating methods with steam: Steamplus, Reheating, Proving, Defrosting, Sous-vide Full Glass Inner door Integrated glass sturdy handle Integral cooling fan Water inlet system: Fixed connection varioClip rails Plus, full extension, with Stop function softMove door 5 shelf levels Automatic rapid heat function Sabbath function Oven assistant with voice control, supports Alexa, Fitbit, Google assist mini, IFTTT
Cleaning Features	<ul style="list-style-type: none"> Drying function ecoClean Plus function for back, ceiling & side liners descaling programme
Safety & Quality features	<ul style="list-style-type: none"> Residual heat indicator Childproof lock function Automatic safety switch off
Dimensions	<ul style="list-style-type: none"> Appliance dimensions (HxWxD): 59.5cm x 59.4cm x 54.8cm Cutout dimensions (HxWxD): 58.5cm - 59.5cm x 56cm - 56.8cm x 55cm
Technical Information	<ul style="list-style-type: none"> Connecting cable: 120cm Total connected load: 3.45 kW Heating temperature: 30°C - 250°C

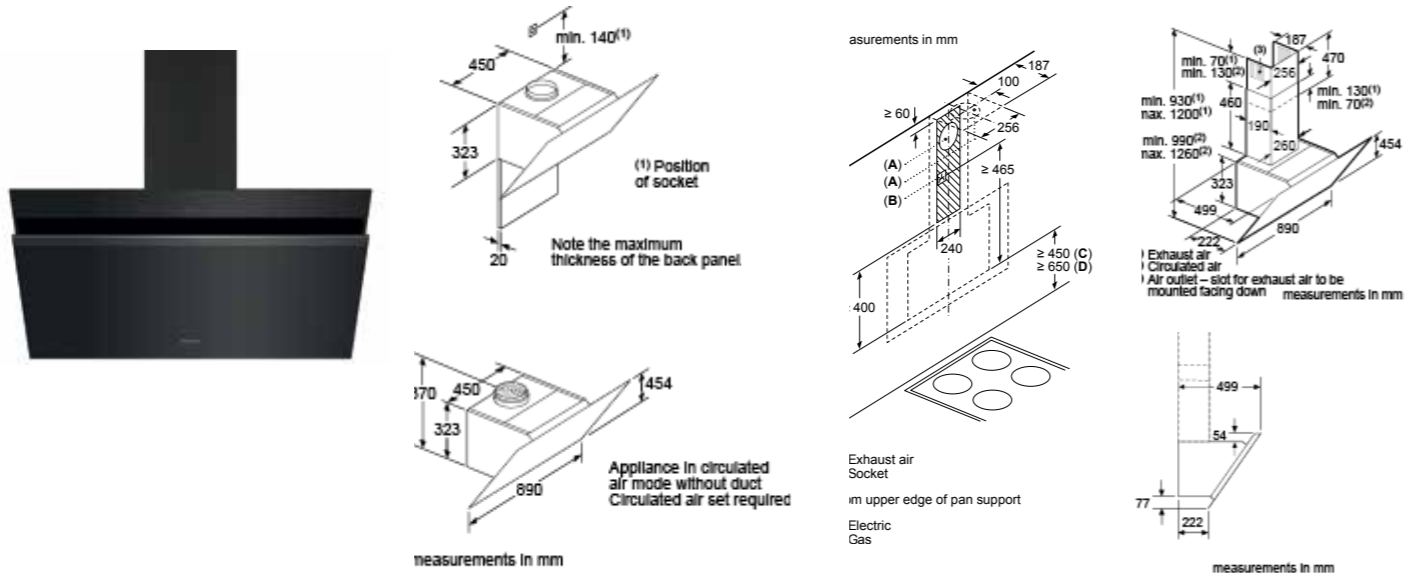

Short Description	90 cm Wall Mounted Hood
Key Highlights	<ul style="list-style-type: none"> Efficient BLDC Motor Technology: iQdrive Fan speed: 3 Stage + 2 Intensive LED softLight with dimmer function Maximum extraction power: 788 m³/h
Design & Innovation features	<ul style="list-style-type: none"> Inclined Hood Touch control with LED Display 2 x LED lights Automatic Fan run - on Function: Duration 10 mins Automatic Intensive revert function: Duration 6mins. Metal grease filter, dishwasher safe Air quality sensor Noise level: 56 dB Suitable for ducted or re-circulated operations
Dimensions	<ul style="list-style-type: none"> Exhaust dimensions (HxWxD): 93-120cm x 89cm x 49.9 cm Re-circulating dimensions (HxWxD): 99 - 126 cm x 89cm x 49.9cm
Technical Information	<ul style="list-style-type: none"> Connecting cable: 130 cm Total connected load: 270 W

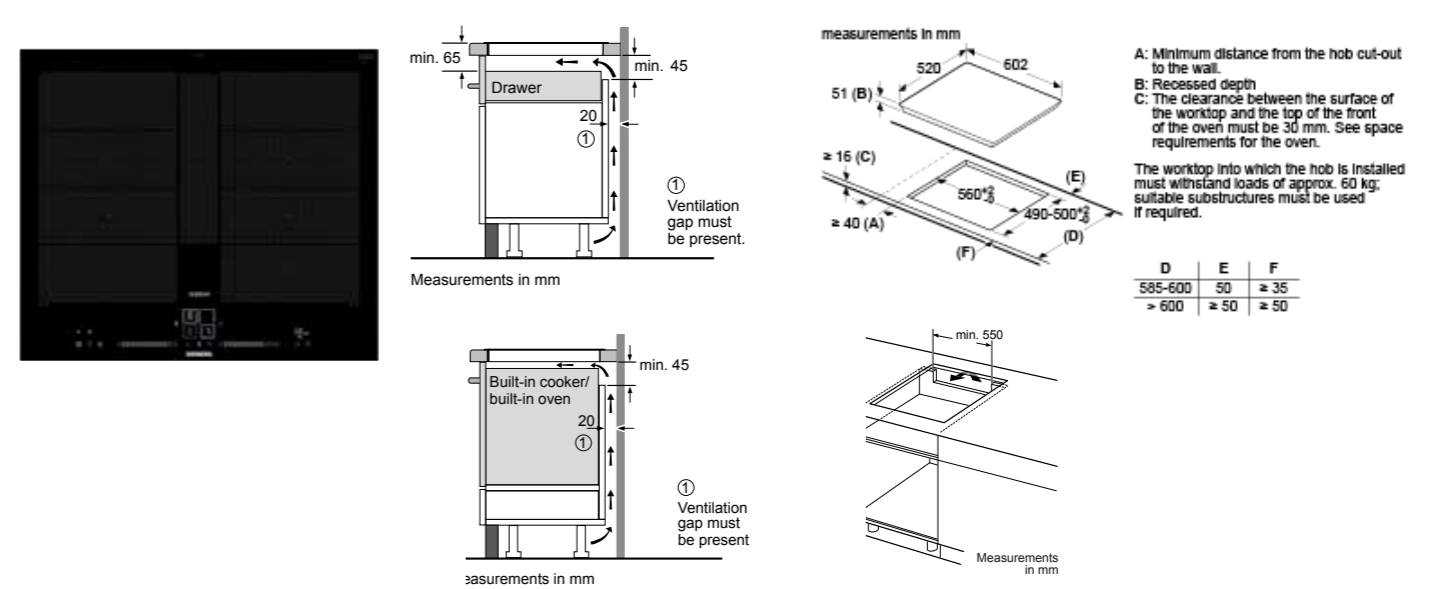

Short Description	60 cm flexInduction Hob
Key Highlights	<ul style="list-style-type: none"> flexInduction Plus 2 Flex zone Dual blue lightSlider touch control Switch off timer for every cooking zone reStart Function quickStart Function Keep warm function for all cooking zones Home Connect Energy consumption display <p>Quickness:</p> <ul style="list-style-type: none"> PowerBoost function for all zones panBoost
Design & Innovation features	<ul style="list-style-type: none"> 17 power levels Black ceramic cover for covering while not being used Count up timer FryingSensor Plus: Maintains the desired pan temperature automatically after heating up to avoid scorching. powerMove Plus: Adjust heat levels in three steps just by moving the cookware
Safety & Quality features	<ul style="list-style-type: none"> Digital - Two step residual heat indicator Automatic pan recognition sensor powerManagement function Automatic safety switch off Childproof lock function Wipe protection function Quick Stop
Dimensions	<ul style="list-style-type: none"> Appliance dimensions (HxWxD): 5.1cm x 60.2cm x 52cm Cut out dimensions (HxWxD): 5.1cm x 56cm x 49-50cm
Technical Information	<ul style="list-style-type: none"> Connection cable: 110 cm Connected load: 7.4 KW

Welcome to your Siemens kitchen.

Discover the new possibilities
of the progressive Siemens
technology.

SIEMENS

Siemens Home Appliances