

Planning Information

WARMING & STORAGE DRAWERS

Model Options

Thermador 30-inch Warming Drawers are available in a push-to-open design with a stainless front or a Custom Panel design. These drawers pair beautifully with a Thermador speed oven or microwave. Thermador 30-inch Storage Drawers are available in a standard or short design. The short design pairs perfectly with a Thermador steam and convection oven. Be sure to reference the correct model information in this design guide.

Installation Considerations

The information in this design guide provides key features, product dimensions, cutouts and installation specifications. Before installing a Thermador Warming Drawer or Storage Drawer, be sure to verify the cabinet dimensions and electrical connections (if required). Installation instructions are subject to change. Always consult with the installation manual included with the product for complete details prior to the installation.

Electrical Specifications

Be sure your appliance is properly installed and grounded by a qualified technician. Installation, electrical connections and grounding must comply with all applicable local codes.

All Thermador Warming Drawers are designed to be connected to a 120V AC, 60 Hz, 3-wire, grounded outlet with a 15 A circuit breaker.

Electrical Location

The outlet can be installed in the back wall directly behind the drawer. A recessed power receptacle must not exceed 5 1/2 ft. (1.7 m) maximum distance from either side of the warming drawer cutout. Installation clearances permit for the excess power cord to be coiled behind the appliance.

Custom Front Panel

The Thermador Custom Panel Warming Drawer requires a custom front panel. You may build a custom drawer front panel to coordinate with your cabinetry. Custom panels must meet the following requirements:

- Have a handle
- Have the dimensions shown below
- Have a minimum thickness of 3/4" (19 mm)
- Have all edges finished
- If using wood, the back must be sealed to prevent moisture damage
- Be capable of withstanding a temperature of 158°F (70° C)

Installation Options

Wall-Mounted Installation

Thermador Warming Drawers may be installed below any Thermador Single or Double Built-in Oven. A minimum space of 1" (25.4 mm) is recommended between the bottom of the oven and the top of the warming drawer.

Under-Counter Installation

Thermador Warming Drawers may also be installed below any Thermador Electric or Non-professional Gas Cooktop as long as there is not contact between the bottom of the cooktop and the top of the warming drawer. When installing below a Thermador

Induction Cooktop, a minimum 1" (25.4 mm) air gap must be maintained between the bottom of the cooktop and the top of the warming drawer. When installing below a Thermador Professional Rangetop, a minimum 2 3/4" (70 mm) air gap must be maintained between the bottom of the rangetop and the top of the warming drawer.

The cabinet base must be flat and capable of supporting a weight of at least 110 lbs. (50 kg).

Side-by-Side Installation

Thermador Warming Drawers and Storage Drawers may be installed side-by-side in combination with a single wall oven. Accessory kit TWO30YS may be required. See page 73 for details on approved combinations for side-by-side installation.

Installation

WARMING & STORAGE DRAWERS

Custom Panel Warming Drawer

WD30W

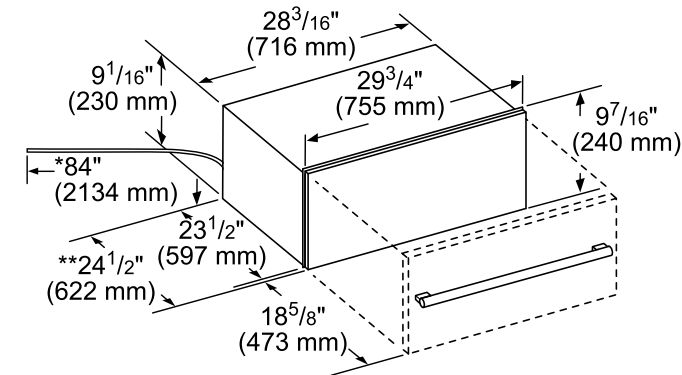

- * Power cable on warming drawer is 84" (2134 mm).
- ** For WD30W, the installed dimension may differ. This is based on 3/4" (19 mm) thick custom panel.
- *** Customer to provide custom panel and drawer handle

measurements in inches (mm)

Cutout Dimensions

WD30W, WD30WC AND SD30WC

Standard Installation

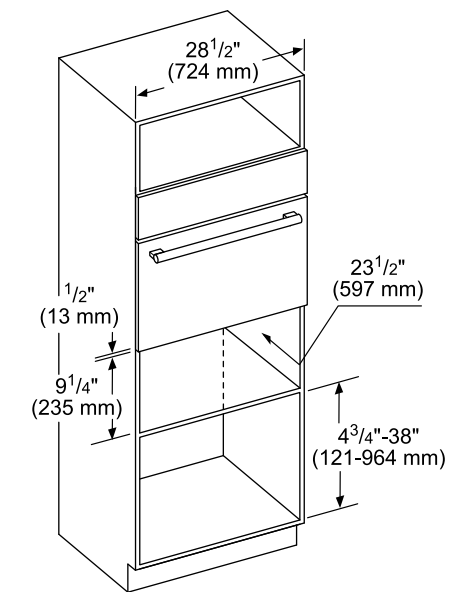

measurements in inches (mm)

Warming Drawer and Storage Drawer

WD30WC AND SD30WC

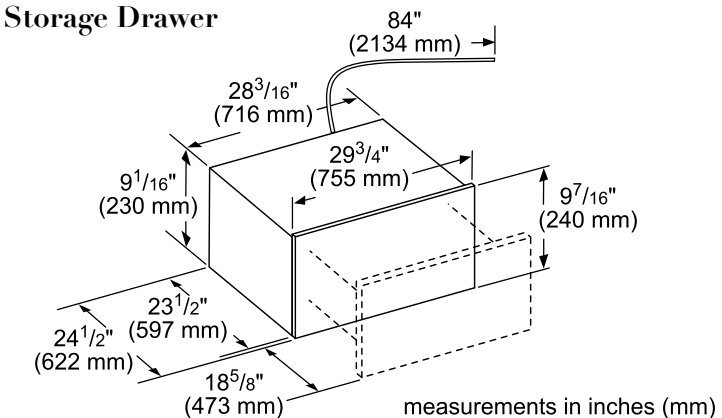

measurements in inches (mm)

Flush Installation

WD30W, WD30WC OR SD30WC

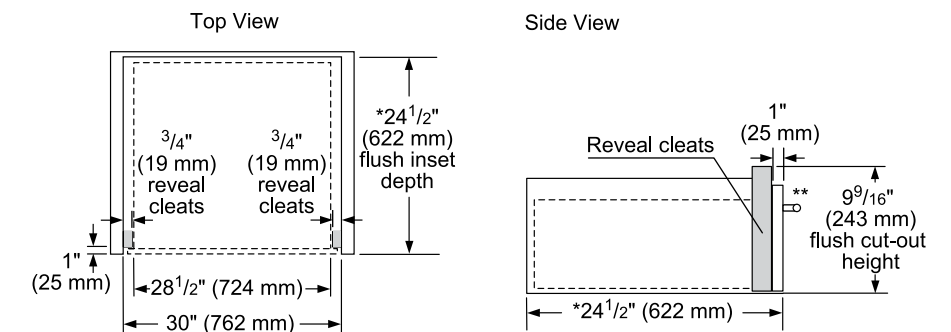

- * For WD30W, the installed dimension may differ. This is based on 3/4" (19 mm) thick custom panel.
- ** Customer to provide custom panel and drawer handle.

measurements in inches (mm)

Installation

WARMING & STORAGE DRAWERS

Flush Installation

SINGLE OVEN OVER STORAGE OR WARMING DRAWER
WD30W, WD30WC OR SD30WC

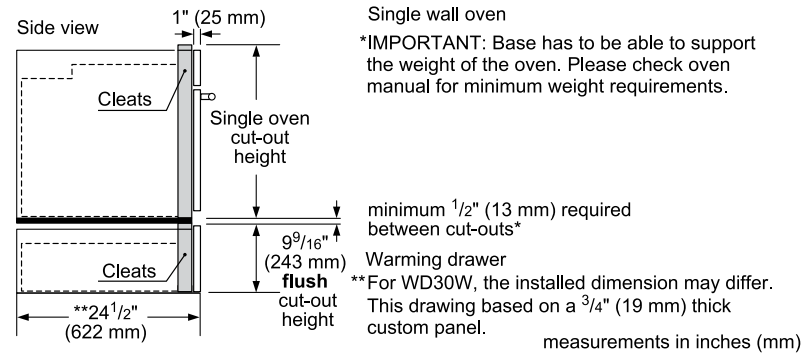

Standard Installation

SINGLE OVEN, DOUBLE OVEN OR COMBO OVEN OVER WARMING OR STORAGE DRAWER
WD30W, WD30WC OR SD30WC

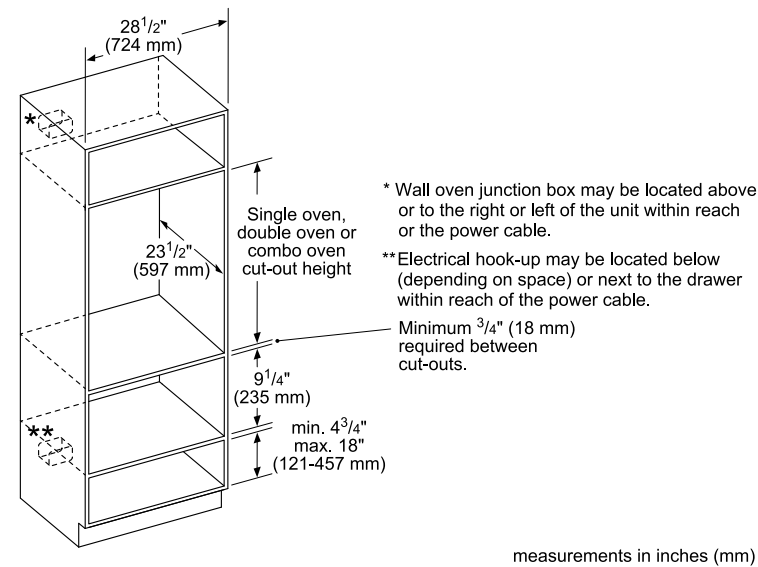

Flush Installation

DOUBLE OR COMBO OVEN OVER STORAGE OR WARMING DRAWER
WD30W, WD30WC OR SD30WC

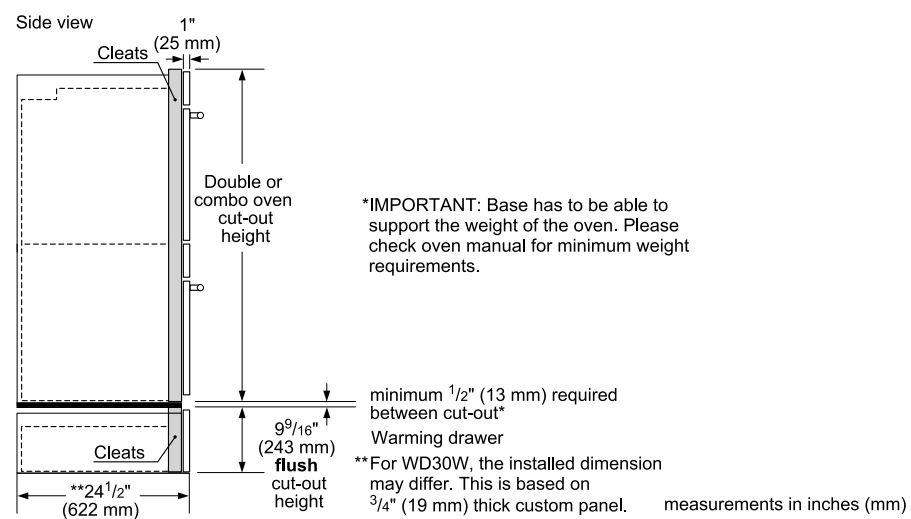

Installation

WARMING & STORAGE DRAWERS

30-Inch Storage Drawer and Cutout Dimensions

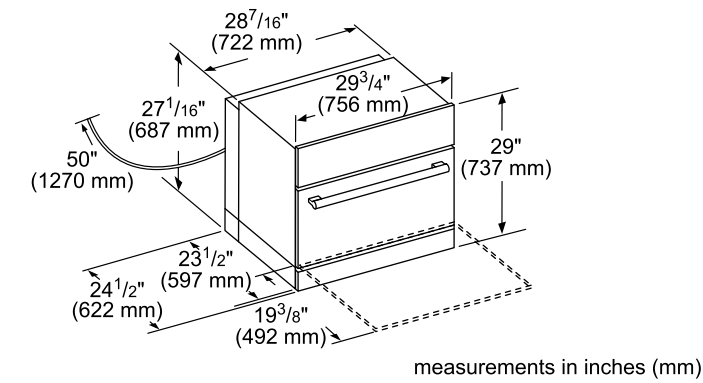

Masterpiece Series Handle

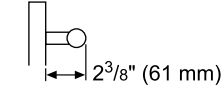

Professional Series Handle

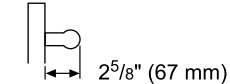

30-Inch Storage Drawer and Cutout Dimensions

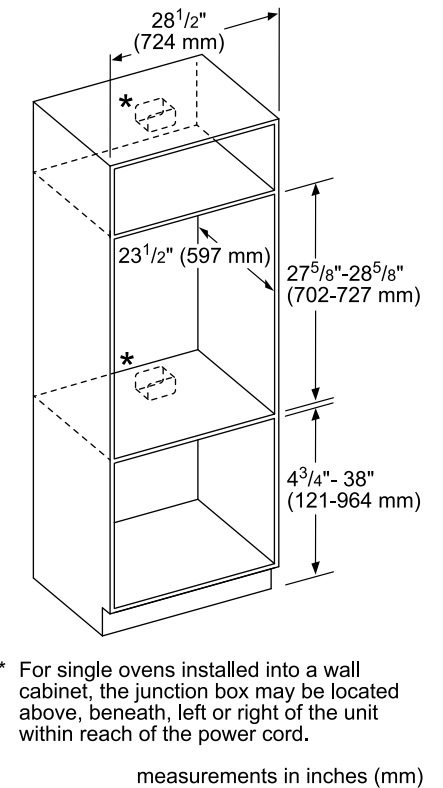

30-Inch Storage Drawer and Cutout Dimensions

Steam Oven with Storage Drawer – Side View

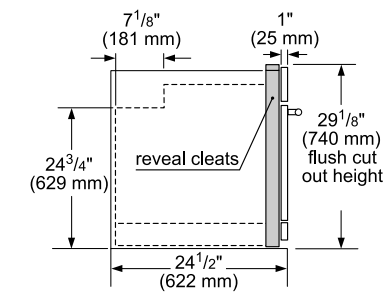

Top View

