

Project Business in Sub-Saharan Africa



BOSCH

Invented for life



www.bosch-home.com.ng
www.bosch-home.co.ke



Bosch: Your Partner for Project Business

By offering built-in appliances that excel in terms of quality, function and design Bosch is your competent partner. After all, quality engineered in Germany is in demand right across the world.

Bosch appliances perfectly combine highest quality and energy efficient products with contemporary European design. Bosch is able to supply a kitchen with appliances ranging from ovens to kettles or coffee machines.

A premium appearance and long term value retention are key characteristics of the brand, providing quality you can see and touch.



BOSCH
Invented for life

Flagship Projects



Weily Kakimo
Conakry, Guinea



Indigo Homes
Accra, Ghana



Eko Pearl Tower
Lagos, Nigeria

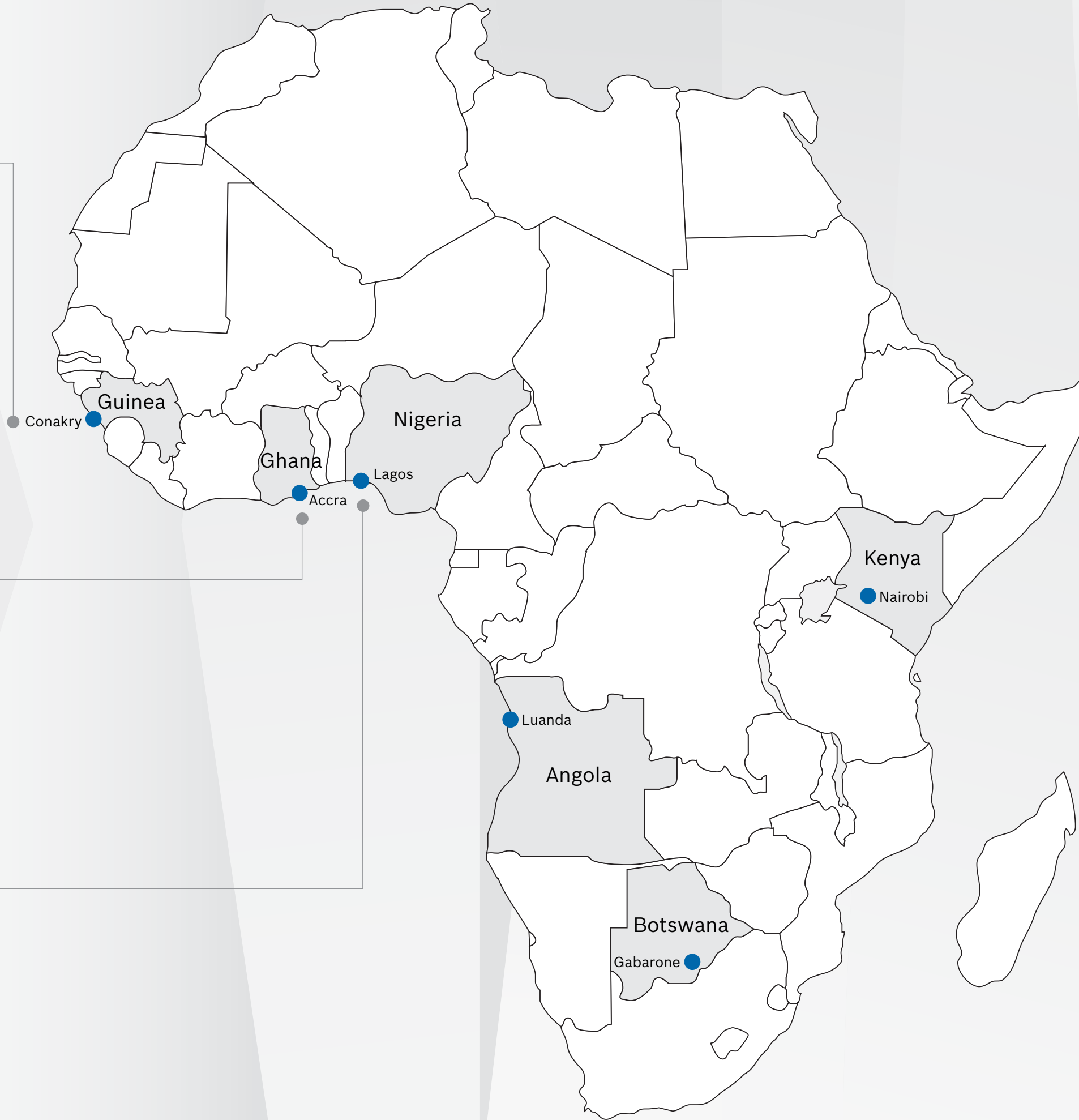

red dot award: product design
Since 1955, the Design Zentrum Nordrhein Westfalen has been marking outstanding international product design with its famous dot. Manufacturers and designers of a wide variety of industrial products can enter their work all year round in eleven product groups for the coveted red dot award.



iF product design award
The iF product design award is one of the world's three leading design awards and can look back proudly on a 50-old-year history. Every year some 2,000 products from around 37 nations are judged by renowned experts, with the best of them receiving an iF seal of outstanding design quality.



Sustainability
The Green Technology inside signet stands for the resource-efficiency of our products – quite simply, a BSH products reflect environmental consciousness.

Customise your own Appliance Set

We have developed a series of options that showcase different set combinations from our range of ovens, hobs, extractors, dishwashers, laundry and refrigeration. Create your own custom configuration or select a package from the combinations listed.

Example Set One

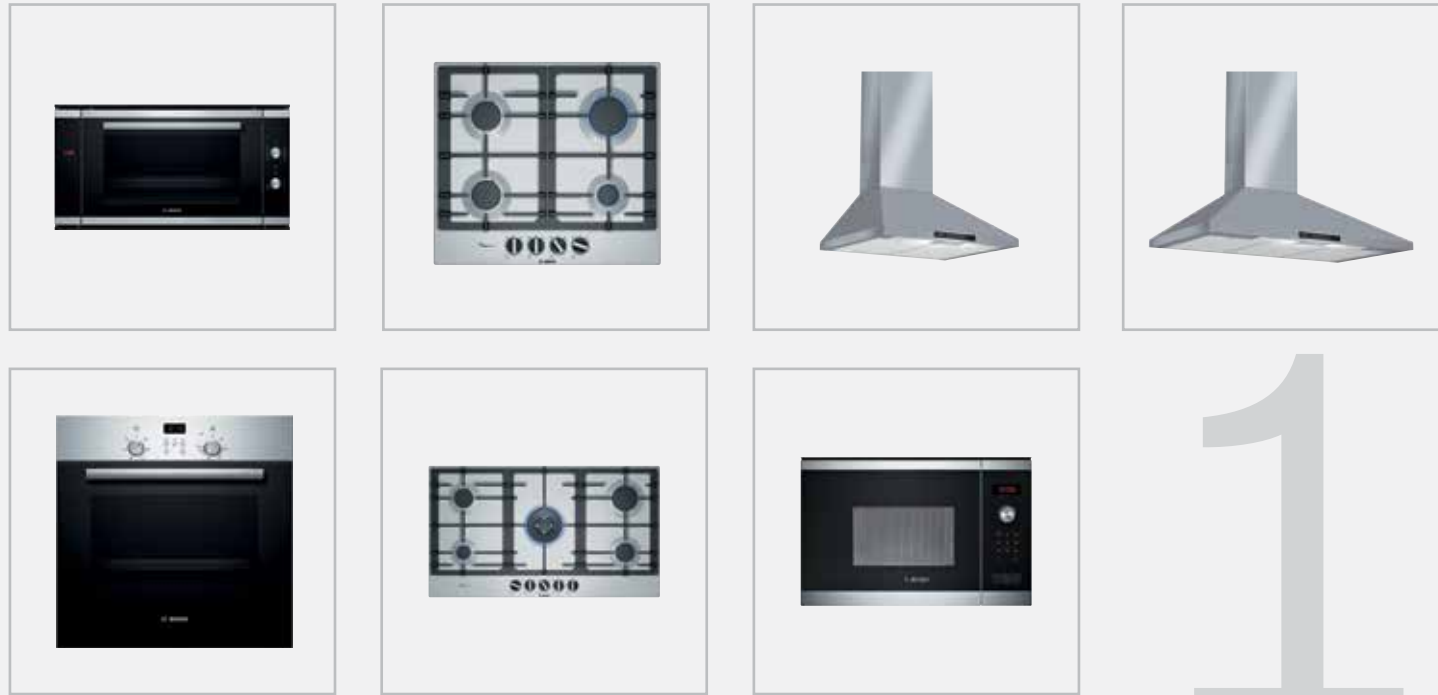

Example Set Three



Example Set Two



Example Set Four



Technical Diagrams

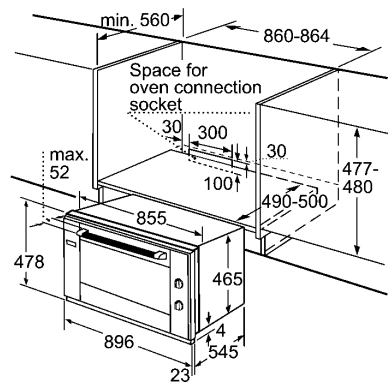

HVA531NS0

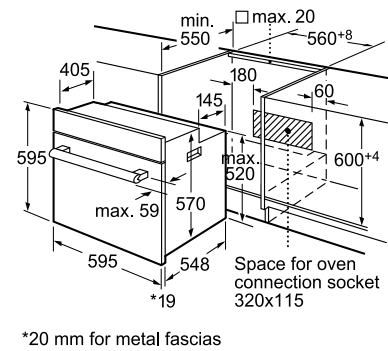

*20 mm for metal fascias
Measurements in mm

HBN231E2M

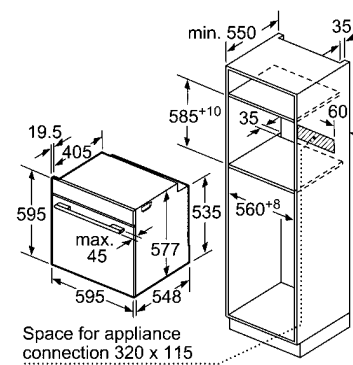

HBG634BS1

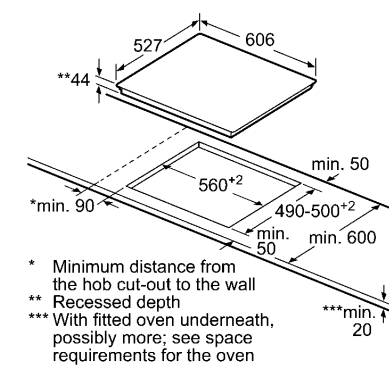

PKF675FP1E

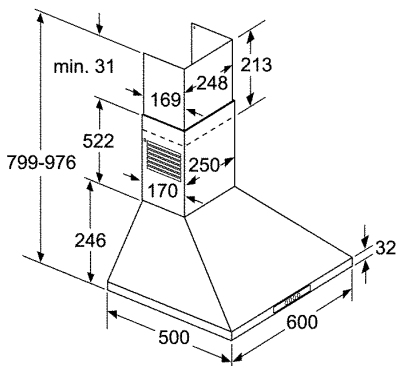

DWW06W450B

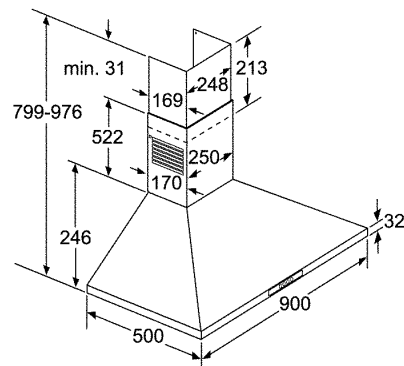

DWW09W45B

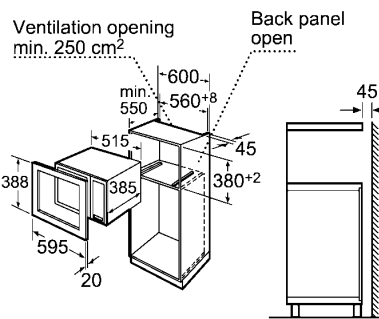

HTM84G654W

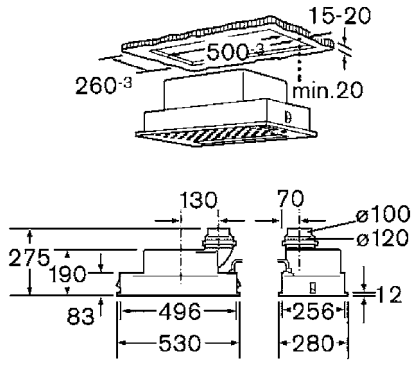

DHL535C

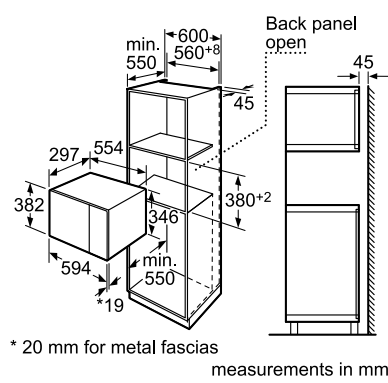

HMT75M654B

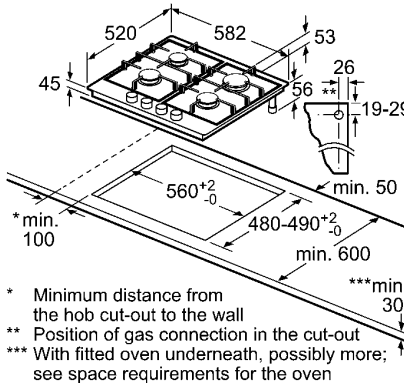

PCP6A5B90

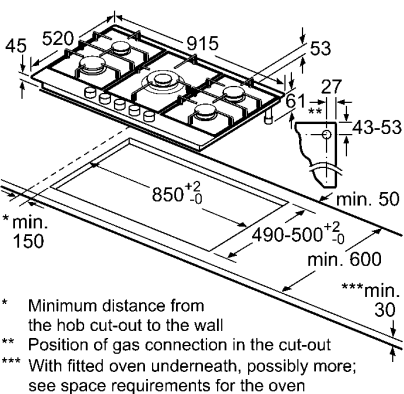

PCR9A5B90

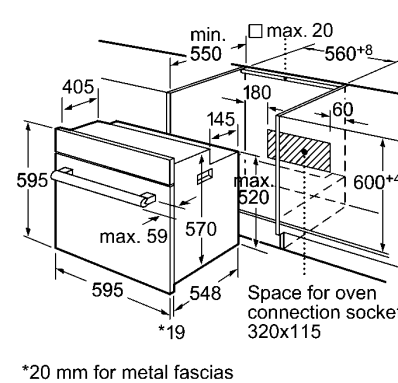

HEN201E2

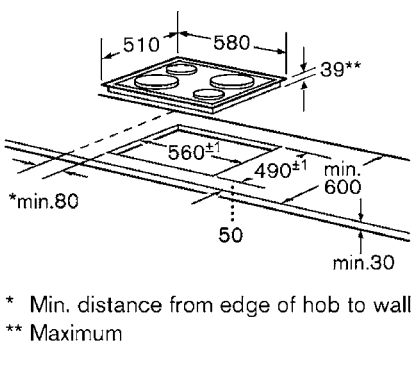

PKE645C17E

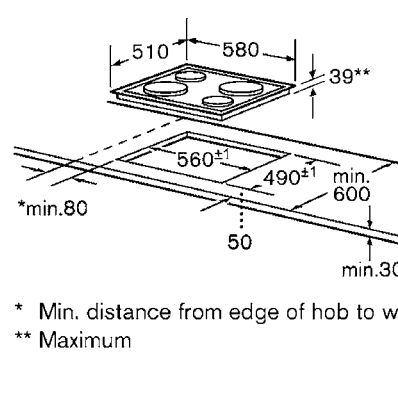

NCM615A01

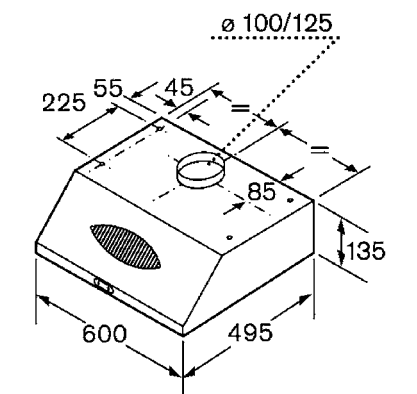

DHU635GZA

Project business expertise

Providing the vital preconditions for successful cooperation – Planning expertise, excellent realisation of plans and reliable maintenance. BSH is the leading partner in the industry chosen to equip large, prestigious real estate properties with home appliances.

After Sales Service

BSH has an extensive customer service network across Africa. Information can be accessed from the Business Development Manager assisting with the Project

BSH Guarantee

BSH prides itself in its products as well as its customer care service. All our appliances come out with guarantee's that vary in length.

Other brands under the BSH banner

SIEMENS

GAGGENAU

Additional products on offer



Security Cameras



Alarms



Water Heaters



Air Conditioners

