



Gaggenau

en-us User manual

DF211700

Dishwasher

Table of contents

1 IMPORTANT SAFETY INSTRUCTIONS.....	3	13 Basic Operation	20
1.1 Safety definitions.....	3	13.1 Protection against unintentional operation	20
1.2 General information.....	3	13.2 Opening the appliance door	20
1.3 Intended use	3	13.3 Switching on the appliance	20
1.4 Restrictive Use.....	3	13.4 Setting a cycle	20
1.5 Grounding instructions	3	13.5 Setting options.....	20
1.6 Safe use.....	3	13.6 Setting the electronic delay time	20
1.7 Risk to children	4	13.7 Starting the wash cycle	20
1.8 State of California Proposition 65 Warnings	4	13.8 Interrupting the wash cycle	20
2 Preventing material damage	5	13.9 Terminating the wash cycle.....	20
3 Environmental protection and energy-saving	5	13.10 Displaying wash cycle information	20
3.1 Saving energy.....	5	13.11 Switching off the appliance	21
3.2 AquaSensor	5	14 Basic settings	22
3.3 Sensors.....	5	14.1 Overview of the basic settings	22
4 Familiarizing yourself with your appliance	6	14.2 Changing the basic settings.....	23
4.1 Appliance	6	14.3 Setting the time.....	23
4.2 Controls	7	15 Home Connect™	23
5 Dishwasher Cycles	9	15.1 Home Connect™ quick start	23
5.1 Energy Guide	9	15.2 Home Connect™ settings	23
5.2 Personalization function 	9	15.3 Remote start 	24
6 Options	10	15.4 Remote Diagnostics	24
7 Features.....	10	15.5 Software update.....	24
7.1 Upper rack	10	15.6 Data Protection.....	24
7.2 Lower rack	11	16 Cleaning and maintenance	24
7.3 Silverware Basket	11	16.1 Cleaning the tub.....	24
7.4 Silverware drawer	12	16.2 Cleaning agent.....	24
7.5 Cup shelf.....	12	16.3 Tips on appliance care.....	24
7.6 Flip tines	12	16.4 Filter system	25
7.7 Baking sheet spray head.....	13	16.5 Cleaning the spray arms	26
7.8 Rack heights	13	17 Troubleshooting	27
8 Before using for the first time	14	18 Transportation, storage and disposal	33
8.1 Initial use.....	14	18.1 Removing the appliance	33
9 Water softening system.....	14	18.2 Vacation and Storage	33
9.1 Overview of water hardness settings.....	14	18.3 Transporting the appliance	34
9.2 Setting the water softening system.....	14	18.4 Disposal of your old appliance	34
9.3 Special Dishwasher Salt	15	19 Customer service.....	34
9.4 Switching off the water softening system.....	15	19.1 Model number (E-Nr.), production number (FD) and consecutive numbering (Z-Nr.).....	34
10 Rinse aid system.....	15	19.2 AquaStop® Pledge	34
10.1 Rinse aid.....	15	20 Technical specifications	35
10.2 Setting the amount of rinse aid.....	16	20.1 Information regarding Free and Open Source Software	35
10.3 Switching the rinse aid system off	16	21 Statement of Limited Product Warranty.....	35
11 Detergent.....	16	21.1 What this Warranty Covers & Who it Applies to	35
11.1 The correct detergents	16	21.2 How Long the Warranty Lasts.....	35
11.2 Incompatible detergents.....	16	21.3 Extended Warranty	35
11.3 Information on Detergent	16	21.4 Repair/Replace as Your Exclusive Remedy.....	36
11.4 Adding Detergent.....	17	21.5 Out of Warranty Product	36
11.5 Detergent table	17	21.6 Warranty Exclusions	36
12 Dishware.....	17	21.7 Obtaining Warranty Service - GG	37
12.1 Damage to glass and dishware	17		
12.2 Loading dishware.....	18		
12.3 Removing dishware.....	18		
12.4 Loading patterns	19		



IMPORTANT SAFETY INSTRUCTIONS

READ AND SAVE THESE INSTRUCTIONS

Read all instructions carefully before use. These precautions will reduce the risk of electrical shock, fire and injury to persons. When using kitchen appliances, basic safety precautions must be followed including those in the following pages.

1.1 Safety definitions

Here you can find explanations of the safety signal words used in this manual.

⚠ WARNING

This indicates that death or serious injuries may occur as a result of non-observance of this warning.

⚠ CAUTION

This indicates that minor or moderate injuries may occur as a result of non-observance of this warning.

NOTICE:

This indicates that damage to the appliance or property may occur as a result of non-compliance with this advisory.

Note: This alerts you to important information and/or tips.

1.2 General information

To reduce the risk of fire, electrical shock, or serious injury, observe the following.

- This appliance is provided with installation instructions and this use and care manual. Read and understand all instructions before using the appliance.
- Keep the manual and the product information in a safe place for future reference or for the next owner.
- Do not connect the appliance if it has been damaged in transit.
- Severe product damage and/or injury could result from the use of unqualified service technicians or non-original parts. All repairs must be performed by an authorized service provider using only original equipment factory replacement parts.
- NSF/ANSI 184 Certified residential dishwashers are not intended for licensed food establishments.

1.3 Intended use

Only use this appliance:

- for cleaning household dishware.
- In private households and in enclosed spaces in a residential environment.

- Up to an altitude of max. 13,100 ft (4000 m) above sea level.

1.4 Restrictive Use

This appliance is not intended for use by persons (including children) with reduced physical, sensory or mental capabilities, or lack of experience and knowledge, unless they have been given supervision or instruction concerning use of the appliance by a person responsible for their safety.

1.5 Grounding instructions

This appliance must be grounded to a metal, permanent wiring system or an equipment grounding conductor must be run with the circuit conductors and connected to the equipment grounding terminal or lead on the dishwasher. See the Installation Instructions included with this dishwasher for more information on electrical requirements.

WARNING

Improper connection of the equipment grounding conductor can result in risk of electric shock.

- ▶ This appliance must be grounded. In the event of a malfunction or breakdown, grounding will reduce the risk of electric shock by providing a path of least resistance for electric current. This appliance is equipped with a cord having an equipment-grounding conductor. Check with an authorized electrician or service representative if you are in doubt whether the appliance is properly grounded.

1.6 Safe use

Follow these safety instructions when using the appliance.

WARNING

To reduce the risk of serious injury, observe the following.

- ▶ Read all instructions before using this dishwasher.
- ▶ Use this dishwasher only for its intended function, which is the washing of household dishware and kitchenware rated as dishwasher safe.
- ▶ Only use detergents or rinsing agents recommended for use in a dishwasher, and keep them out of the reach of children.
- ▶ Do not abuse, sit or stand on the door or dish racks of the dishwasher.



IMPORTANT SAFETY INSTRUCTIONS

READ AND SAVE THESE INSTRUCTIONS

WARNING

Under certain conditions, hydrogen gas may be produced in a hot water system that has not been used for two weeks or more. Hydrogen gas is explosive.

- ▶ Before using a dishwasher that is connected to a hot water system that has been unused for two weeks or longer, turn on all hot water faucets and let the water flow from each for several minutes. This will release any accumulated hydrogen gas. As the gas is explosive, do not smoke or use an open flame during this time.

WARNING

To avoid risk of electric shock, observe the following.

- ▶ Only use the appliance in enclosed residential space according to the installation manual.
- ▶ Never expose the appliance to intense heat or humidity.
- ▶ Do not use any steam cleaners or high-pressure cleaners to clean this appliance. If not followed, excess moisture can accumulate.

WARNING

To avoid risk of injury, when loading items to be washed, observe the following.

- ▶ Locate sharp items so they are not likely to damage the door seal.
- ▶ Load knives and other sharp utensils with their handles up to reduce the risk of cut-type injuries.
- ▶ Do not wash plastic items unless they are marked "dishwasher safe" or the equivalent. For plastic items not so marked, check the manufacturer's recommendations.
- ▶ Do not operate your dishwasher unless all enclosure panels are in place.
- ▶ Do not tamper with or override controls and interlocks.

WARNING

For safe care and operation of your appliance, observe the following.

- ▶ Follow the safety instructions and directions for use on the detergent and rinse aid product labels.
- ▶ Do not use harsh chemicals such as bleach-based products to clean your dishwasher. Some bleach-based products can damage your dishwasher and may present health hazards!

- ▶ Always use caution when opening the door during or following a wash cycle as hot water or steam may escape. Do not fully open the door until water noises have stopped and steam has subsided.
- ▶ To avoid floor damage and possible mold growth, do not allow wet areas to remain around or under the dishwasher.

NOTICE:

Water and power shut off

- ▶ It is highly recommended for the end user to become familiar with the procedure to shut off the incoming water supply and the procedure to shut off the incoming power supply. See the installation instructions or contact your installer for more information.

1.7 Risk to children

Follow these safety instructions if there are children in your home.

WARNING

To reduce risk of injury to children, observe the following.

- ▶ Do not allow children to play in or on the dishwasher.
- ▶ When children become old enough to operate the appliance, it is the responsibility of the parents/legal guardians to ensure the children are instructed in safe practices by qualified persons.
- ▶ Remove the dishwasher door to the washing compartment when removing an old dishwasher for service or discarding.

1.8 State of California Proposition 65 Warnings

This product may contain a chemical known to the State of California, which can cause cancer or reproductive harm. Therefore, the packaging of your product may bear the following label as required by California:

STATE OF CALIFORNIA PROPOSITION 65 WARNING:



WARNING

Cancer and Reproductive Harm - www.P65Warnings.ca.gov

2 Preventing material damage

NOTICE:

Harsh chemicals such as bleach-based products can damage your dishwasher.

- ▶ Do not use harsh chemicals such as bleach-based products to clean your dishwasher.

Unsuitable cleaning products may damage the appliance.

- ▶ Do not use a steam cleaner.
- ▶ So as not to scratch the finish on the appliance, do not use sponges with a rough surface or abrasive cleaning agents.
- ▶ To prevent corrosion, do not use cellulose sponge cloths on dishwashers with a stainless steel front or rinse the cloths thoroughly several times before using them for the first time.

Escaping water vapor can damage cabinetry.

- ▶ When the program ends, let the appliance cool down a bit before opening the door.

Protect your appliance from the elements.

- ▶ Protect against freezing to avoid possible damage to the fill valve. Damage caused by freezing is not covered by the warranty.

Special salt for dishwashers can damage the tub due to corrosion.

- ▶ To make sure that any special salt that escapes is washed out of the tub, add the special salt to the dispenser for special salt immediately before the program starts.

Detergent may damage the water softening system.

- ▶ Only fill the dispenser of the water softening system with special dishwasher salt.

3 Environmental protection and energy-saving

3.1 Saving energy

If you follow these instructions, your appliance will use less power and water.

Use the Eco program.

- ✓ The Eco program is energy-efficient and environmentally friendly.

→ *"Dishwasher Cycles"*, Page 9

Change the sensor setting to the default.

- ✓ Consumption is reduced.

→ *"Sensors"*, Page 5

3.2 AquaSensor

The AquaSensor is an optical measuring device (light barrier) which measures the turbidity of the washing water.

You can save water with the AquaSensor.

The operation of the AquaSensor depends on the selected cycle. If the soiling level is high, the washing water is drained off and replaced with fresh water. If the soiling level is lower, the washing water is used in the next wash cycle, so reducing water consumption by 3-6 liters. In the Auto cycles the temperature and run time are additionally adjusted to the level of soiling.

3.3 Sensors

The sensors adjust the cycle sequence and strength in the Auto cycles depending on the level and type of soiling. The sensor has different sensitivity levels that can be changed in the basic settings.

→ *"Changing the basic settings"*, Page 23

Sensor setting	Description
Standard	Optimal setting for mixed loads and heavily soiled dishware. Saves both energy and water.
Sensitive	Adjusts the program strength for effective removal of food remnants even with low soiling levels. Energy and water consumption are adjusted accordingly.
Very sensitive	Adjusts the program strength for difficult conditions of use, e.g. stubborn dried-on food remnants. Recommended setting when using organic or ecological detergents containing low levels of active agents. Energy and water consumption are adjusted accordingly.

4 Familiarizing yourself with your appliance

4.1 Appliance

Here you can find an overview of the parts of your appliance.

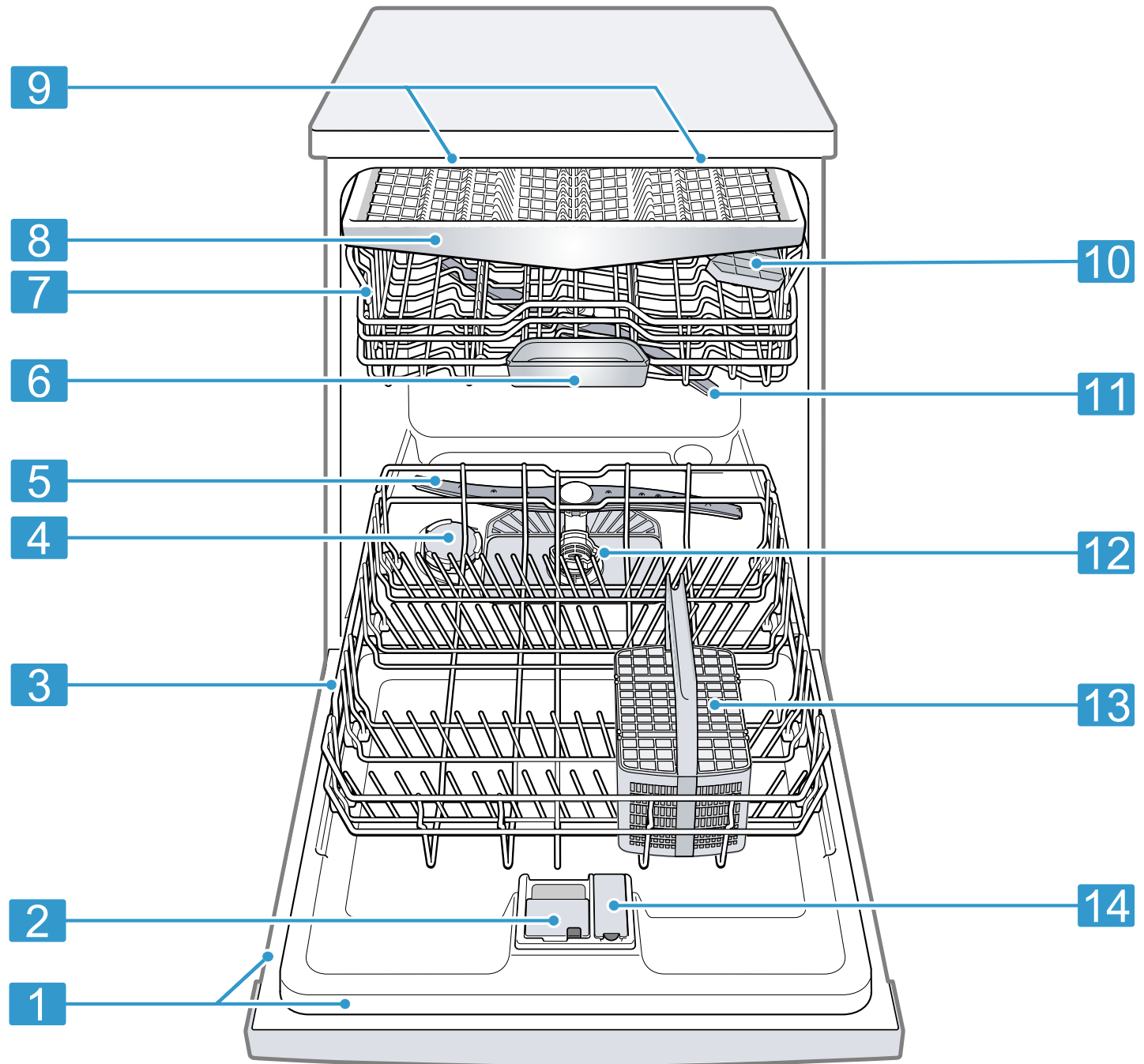

1	Rating plate	Rating plate with E number and FD number → <i>Page 34</i> . You will need this data to contact Customer service → <i>Page 34</i> .
2	Detergent dispenser	Detergent is added to the detergent dispenser.
3	Lower rack	Lower rack → <i>Page 11</i>

¹ Depending on the appliance specifications

4	Dispenser for special salt	Special salt is added to the dispenser for special salt. → "Water softening system", Page 14
5	Lower spray arm	The lower spray arm washes the dishware in the lower rack. If the dishware has not been washed properly, clean the spray arms. → "Cleaning the spray arms", Page 26
6	Detergent tab collecting tray	During the wash cycle, detergent tabs automatically drop out of the detergent dispenser into the tab collecting tray, where they can dissolve fully.
7	Upper rack	Upper rack
8	Silverware drawer	Silverware drawer → Page 12
9	EmotionLight	Interior lighting of the appliance. → "Overview of the basic settings", Page 22
10	Cup shelf ¹	Cup shelf → Page 12
11	Upper spray arm	The upper spray arm washes the dishware in the upper rack. If the dishware has not been washed properly, clean the spray arms. → "Cleaning the spray arms", Page 26
12	Filter system	Filter system → Page 25
13	Silverware basket	Silverware basket
14	Dispenser for rinse aid	Rinse aid is added to the dispenser for rinse aid. → "Rinse aid system", Page 15

¹ Depending on the appliance specifications

4.2 Controls



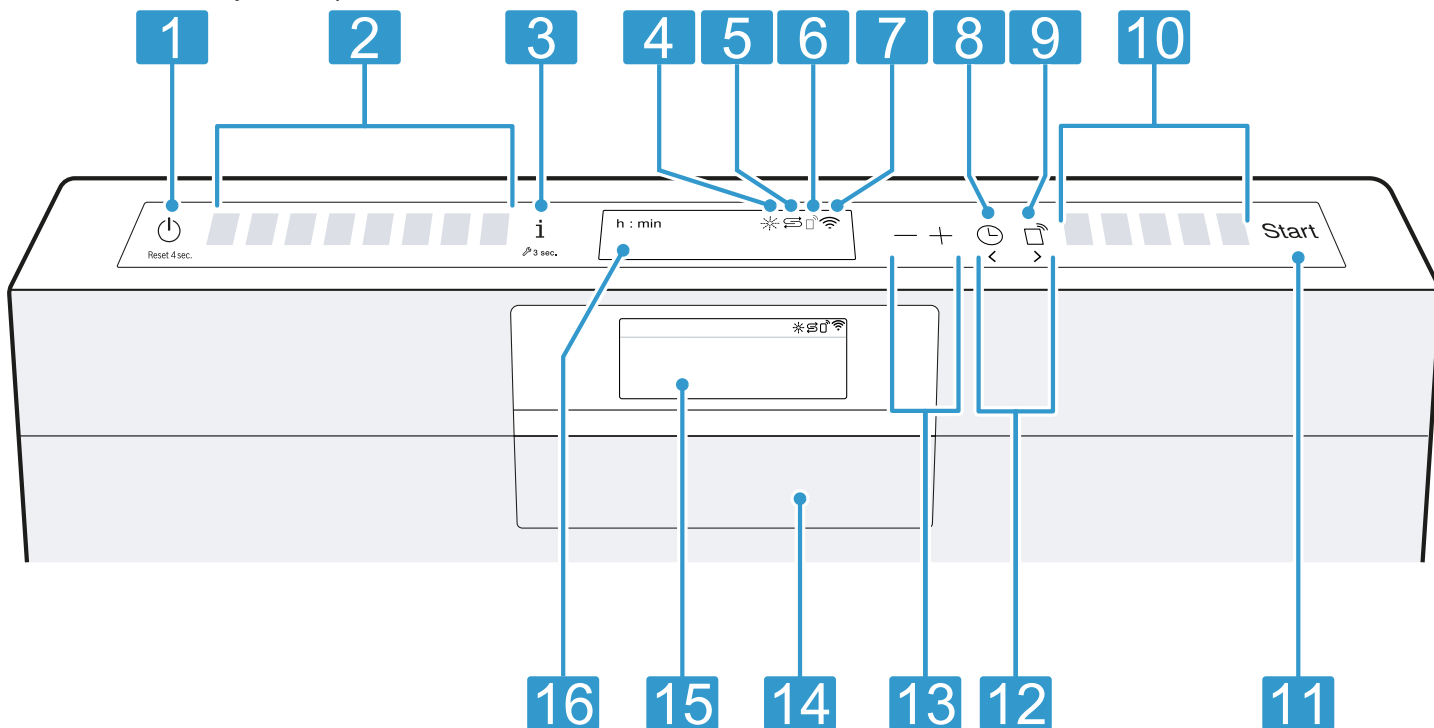

You can use the control panel to configure all functions of your appliance and to obtain information about the operating status.

With some buttons you can perform different functions.



1	ON/OFF button ON/OFF and reset button Reset 4 sec.	Switching on the appliance → Page 20 Switching off the appliance Terminating the wash cycle → Page 20
----------	---	---

¹ Depending on the appliance specifications





2	Cycle buttons	Cycles
3	Info button 	If you press  , the display shows information about selected cycles, basic settings and additional options. If you press  for approx. 3 seconds, you can open the menu. → "Changing the basic settings", Page 23
4	Rinse aid refill indicator	Rinse aid system → Page 15
5	Special salt refill indicator	Water softening system → Page 14
6	Display Remote Start ¹	If you have activated the function and are controlling the appliance via the Home Connect™ app, the display lights up on the appliance.
7	WLAN display	Home Connect → Page 23
8	Electronic delay time	Setting the electronic delay time → Page 20
9	Remote Start 	
10	Cycle buttons and options	Cycles Options
11	Start button Start	Starting the wash cycle → Page 20
12	<> buttons	You can use these buttons to scroll between the basic settings. → "Changing the basic settings", Page 23
13	Setting buttons	Changing the basic settings → Page 23
14	Door opener ¹	Open the appliance door. → Page 20
15	Display ¹	The display shows information about cycles, basic settings or additional options. You can change the basic settings via the display and the setting buttons. → "Changing the basic settings", Page 23
16	Display	The display shows information about cycles, basic settings or additional options. You can change the basic settings via the display and the setting buttons. → "Changing the basic settings", Page 23

¹ Depending on the appliance specifications

5 Dishwasher Cycles

Below is an overview of the different cycles available on your dishwasher.

The running time may vary depending on the cycle selected. The running time depends on the water temperature, the quantity of dishware, the level of dirt and the option selected. The running time will change if the rinse aid system is switched off or rinse aid needs to be added. The consumption values relate to normal conditions and a water hardness of 16 - 20 °E. Different influencing factors such as water temperature or pipe pressure may result in deviations.

Cycle	Purpose	Cycle sequence	Usage 1) Hour/min. 2) Electrical/kWH 3) Water/gal
Auto 150-160 °F	Dishware: <ul style="list-style-type: none"> Washing pots and pans, non-fragile dishware and silverware Level of soiling: <ul style="list-style-type: none"> Removing stubborn burned or dried on food remnants containing starch and protein. 	Intensive <ul style="list-style-type: none"> Pre-Rinse Cleaning 151 °F – 160 °F Intermediate rinse Final rinse 162 °F Drying 	<ul style="list-style-type: none"> 1) 1:40 - 2:00 2) 0.950 - 1.100 3) 4.9 - 6.4
Auto 130-150 °F	Dishware: <ul style="list-style-type: none"> Cleaning mixed dishware and silverware. Level of soiling: <ul style="list-style-type: none"> Removing common household food remnants lightly dried-on. 	Sensor controlled: <ul style="list-style-type: none"> Optimized by sensors depending on the soiling of the rinsing water. 	<ul style="list-style-type: none"> 1) 1:50 - 2:20 2) 0.810 - 0.850 3) 2.5 - 5.4 Note: The displayed cycle time indicates an average value.
 Eco	Dishware: <ul style="list-style-type: none"> Cleaning mixed dishware and silverware. Level of soiling: <ul style="list-style-type: none"> Removing common household food remnants lightly dried-on. 	Most economical cycle: <ul style="list-style-type: none"> Pre-Rinse Cleaning 122 °F – 131 °F Intermediate rinse Final rinse 154 °F Drying 	<ul style="list-style-type: none"> 1) 2:10 - 2:15 2) 0.750 - 0.840 3) 2.3 - 5.6
 Glasscare	Dishware: <ul style="list-style-type: none"> Cleaning temperature sensitive dishes, silverware, and glasses. Level of soiling: <ul style="list-style-type: none"> Removing lightly adhered fresh food remnants. 	Particularly gentle and improved drying: <ul style="list-style-type: none"> Pre-rinse Cleaning 122 °F Intermediate rinse Final rinse 140 °F/60 °C Shine and Dry 	<ul style="list-style-type: none"> 1) 1:15 2) 0.600 3) 3.5
 Quick Wash	Dishware: <ul style="list-style-type: none"> Cleaning delicate dishware, silverware, temperature-sensitive plastics and glasses. Level of soiling: <ul style="list-style-type: none"> Removing lightly adhering fresh food remnants. 	Time-optimized: <ul style="list-style-type: none"> Cleaning 113 °F Intermediate rinse Final rinse 127 °F 	<ul style="list-style-type: none"> 1) 0:30 2) 0.500 3) 2.0
 Personalization function	-	-	<ul style="list-style-type: none"> 1) 0:09 - 0:09 2) 0.050 - 0.050 3) 1.2 - 1.2

5.1 Energy Guide

The Energy Guide label was based on the Normal soil sensing cycle.

The unit was tested without any rinse aid (liquid) in the rinse aid dispenser. A single dose of detergent was inserted into the detergent dispenser, with no detergent being used in the prewash. The unit was not subjected to truncated testing per the definitions in the test procedure. We recommend that dish loads such as the one in the energy certification test have the rack position set in the

highest position. Recommended for daily, regular or typical use to completely wash a full load of normally soiled dishes.

5.2 Personalization function

With this function, you can save a combination of a Cycle and an Option.

You can save the selected Cycle and Option combination via the Home Connect app or on the appliance.

The pre-rinse cycle is pre-programmed to this button and is fine for all types of dishware. The dishware is rinsed with cold water.

Tip: You can use the Home Connect app to download additional Cycles and Options and save them.¹

Save Personalization function  on the appliance.



1. Press ON/OFF.
 2. Press the right cycle button.
 3. Press the button for the relevant options.
 4. Press Personalization Function button for 3 seconds.
- ✓ The selected cycle and option will flash.
 - ✓ The Personalization Function button flashes.
 - ✓ The program combination is saved.

Tip: To reset the cycle, either use the Home Connect app or reset your appliance back to the factory settings.

→ "Overview of the basic settings", Page 22

6 Options

You can find an overview of the options that can be selected here. Different options, which can be found on the control panel of your appliance, are available depending on the appliance configuration.

Option	Use
 Extra Dry	<ul style="list-style-type: none"> ■ For a better drying result, the final rinse temperature is increased and the drying phase extended. ■ Especially suitable for drying plastic parts. ■ There is a slight increase in energy consumption and the run time is extended.
 Intensive	<ul style="list-style-type: none"> ■ Switch on with mixed loads containing dishware with different soiling levels, e.g. place very soiled pots and pans in the lower rack and normally soiled dishware in the upper rack. ■ The spray pressure in the lower rack is increased and the maximum program temperature held longer. This will increase the run time and energy consumption.
 Power	<ul style="list-style-type: none"> ■ The run time is shortened by 15% to 75% depending on the wash cycle. ■ An option can be added to the cycle before it starts or at any time when the cycle is running. ■ Energy and water consumption are increased.

7.1 Upper rack

Arrange cups and glasses in the upper rack.

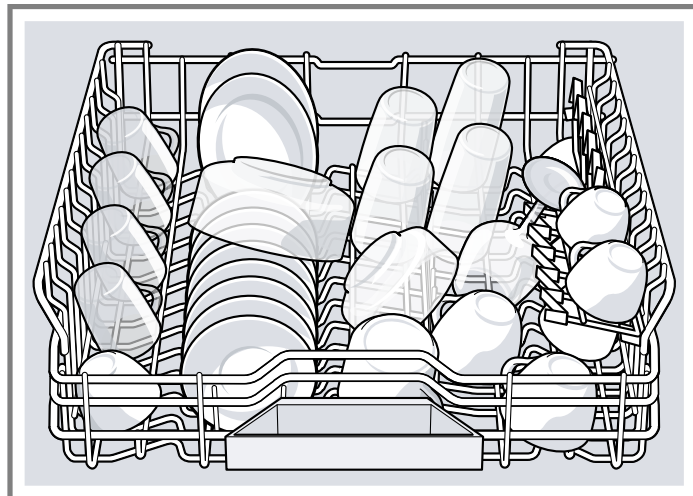

You can adjust the height of the upper rack to make room for larger items.

Adjusting upper rack with the side levers

To wash large items in the racks, adjust the shelf height of the upper rack.

1. Pull out the upper rack.
2. To prevent the rack from suddenly dropping down, hold the side of the rack by the top edge.
3. Press in the right- and left-hand levers on the outside of the rack.

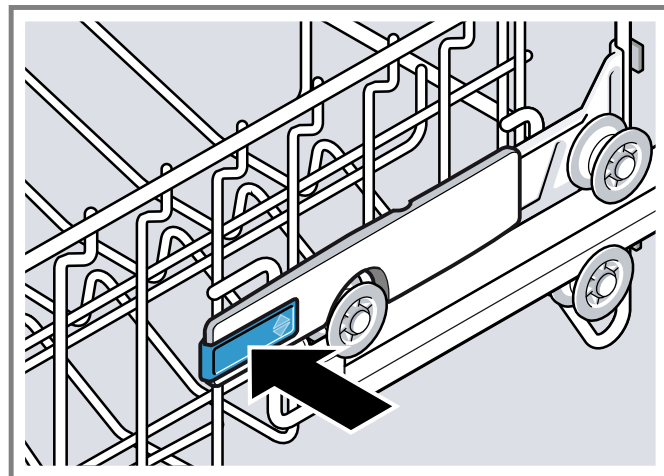

The rack can then slip down slightly.

7 Features

You can find an overview of the possible features of your appliance and how to use them here. These features depend on your appliance model.

¹ Depending on the appliance specifications

4. Raise or lower the rack evenly to the right level.
→ "Rack heights", Page 13

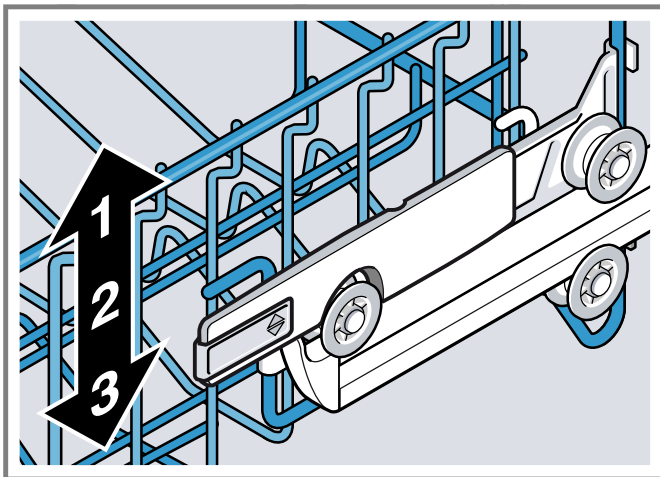

Check that the rack is level on both sides.

5. Slide the rack in.

7.2 Lower rack

Arrange pans and plates in the lower rack.

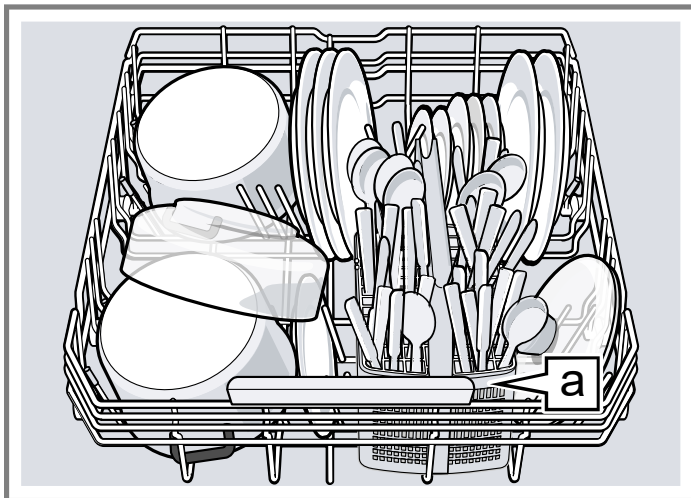

Silverware basket [a]¹

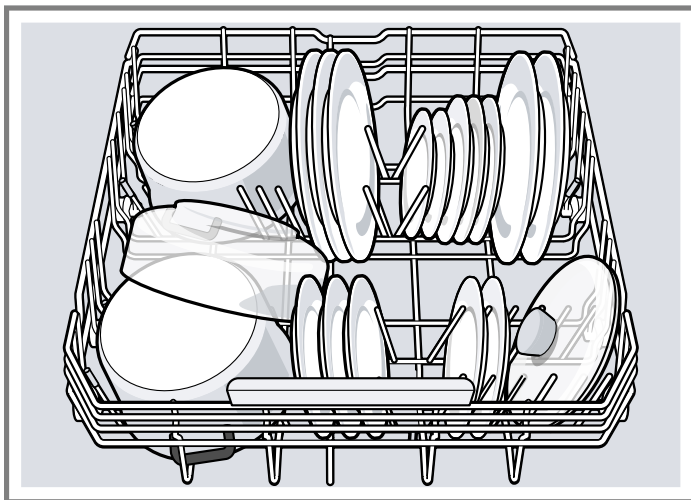

Large plates up to a diameter of 13 inches can be arranged in the lower rack as shown.

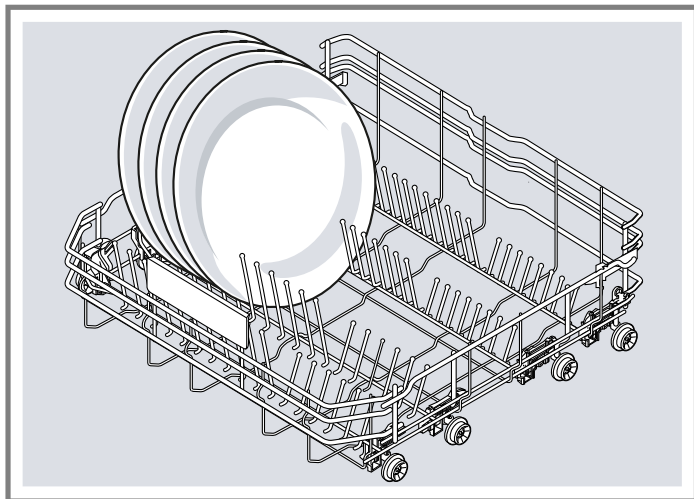

7.3 Silverware Basket

Arrange the silverware in the silverware basket, ensuring that the items are not nestled together and with the sharp points down.

⚠ WARNING

The sharp points and edges of knives and other sharp utensils can cause serious injury.

- ▶ Load knives and other sharp utensils with edges down.
Do not allow children to handle or play near knives and sharp utensils

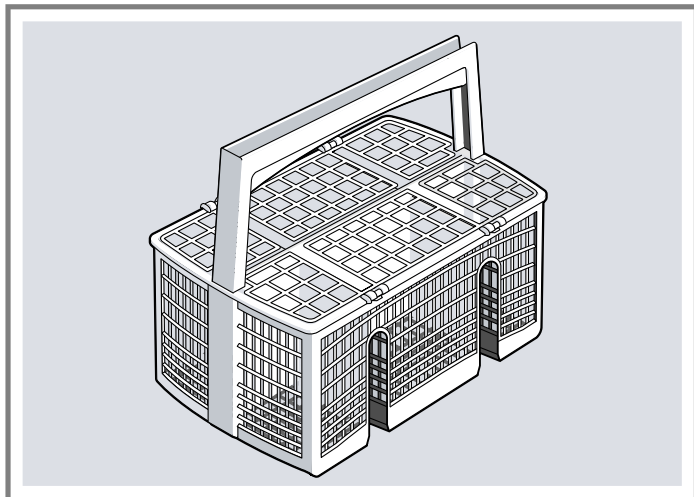

¹ Depending on the appliance specifications

7.4 Silverware drawer

Arrange silverware in the silverware drawer.

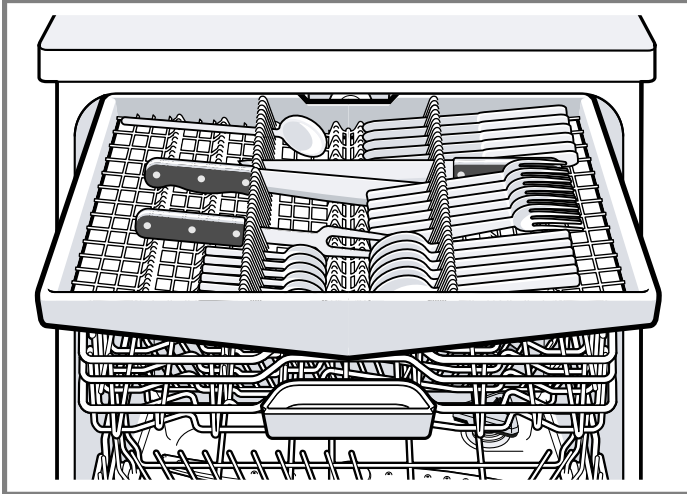

Arrange silverware with the points and sharp edges down. You can reorganize the silverware drawer to make more space for longer or wider utensils.

Reorganizing the silverware drawer

You can fold down the side shelves and front tines to make more space for longer/wider items of silverware.

1. To fold down a side shelf, push the lever forward ① and fold down the side shelf ②.
2. To fold down the front tines, push the lever forward and fold down the tines ③.

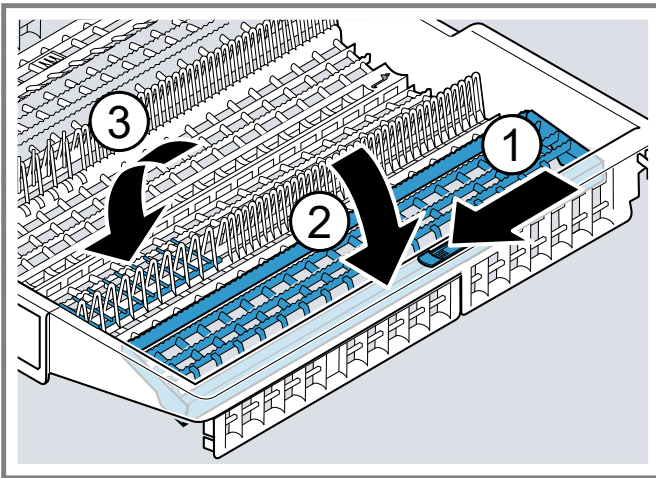

Tip

If you want to return the silverware drawer to its original position, fold the side shelf back up until it clicks into position.

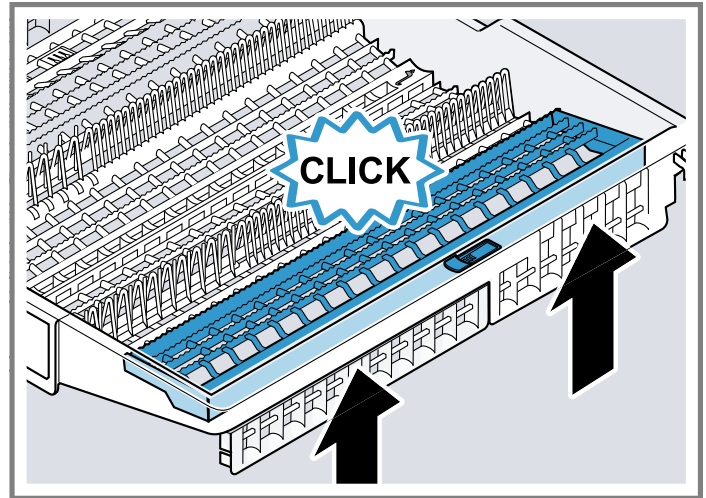

7.5 Cup shelf

Use the cup shelf and the space underneath for small cups and glasses or for large items of silverware, e.g. cooking spoons or serving cutlery.

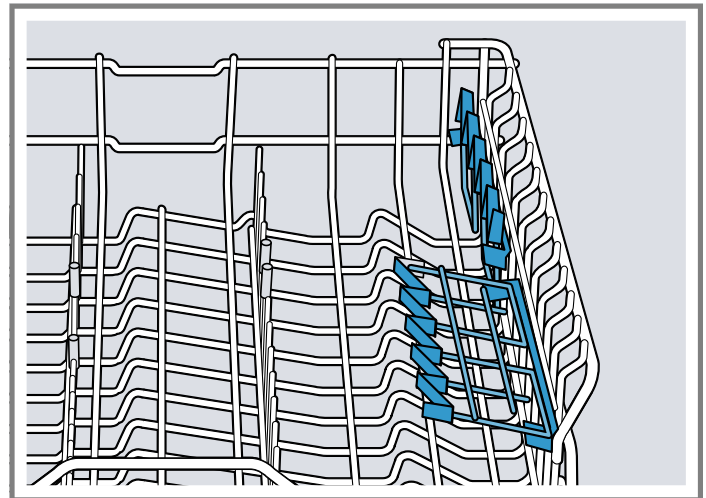

If you do not need the cup shelf, you can fold it up.

7.6 Flip tines

Use the flip tines to position dishware securely, e.g. plates.

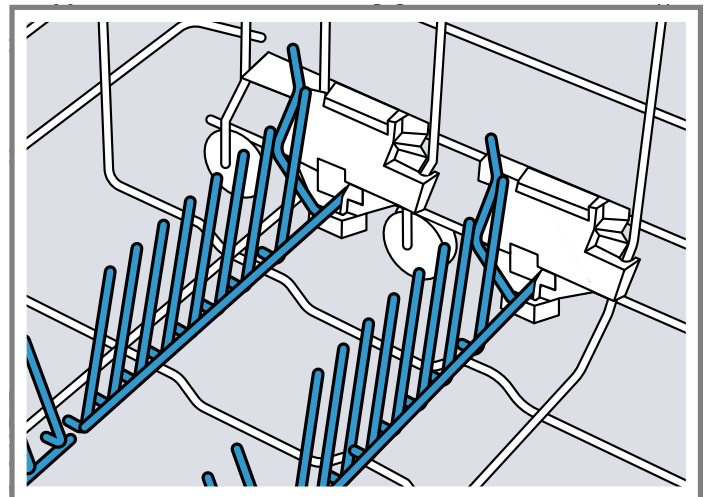

You can fold the tines down to arrange pans, bowls and glasses better.¹

Folding down the tines¹

If you do not need the tines, fold them down.

1. Push the lever forward ① and fold down the tines ②.

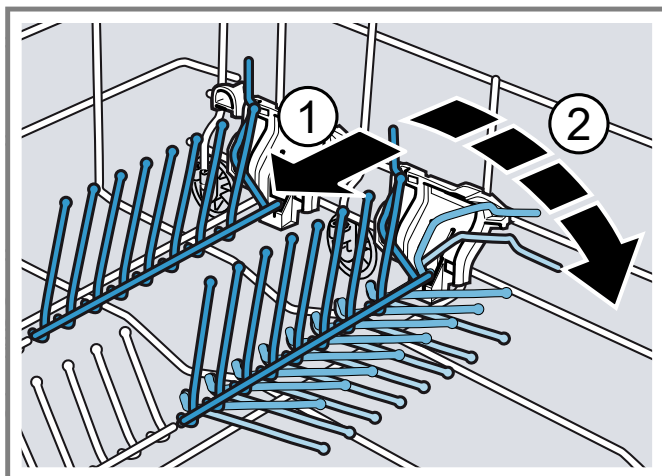

2. To use the tines again, fold them back up.

✓ The tines click into position.

7.7 Baking sheet spray head

Use the baking sheet spray head to clean large items of dishware, e.g. trays, racks and plates.

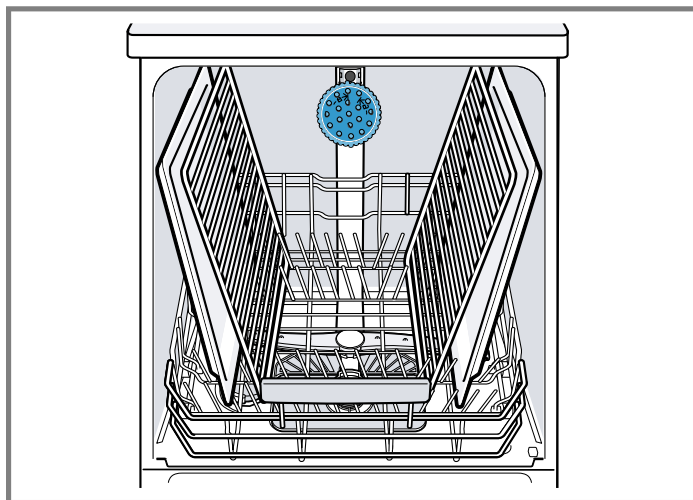

7.8 Rack heights

Set the racks at the right height.

Appliance height 34" with silverware basket

Level	Upper rack	Lower rack
1 max. ø	9.5"	13"
2 max. ø	10.5"	12"
3 max. ø	11.5"	11"

Arrange max. 2 baking sheets and 2 racks as shown to ensure that the spray jet can reach all parts.

Note: Check that the appliance is always operated with the upper rack or the baking sheet spray head.

Inserting the baking sheet spray head

Use the baking sheet spray head instead of the upper rack to clean large trays, racks and plates.

1. Remove the upper rack.
2. Insert the baking sheet spray head in the holder ① and turn to the right ②.

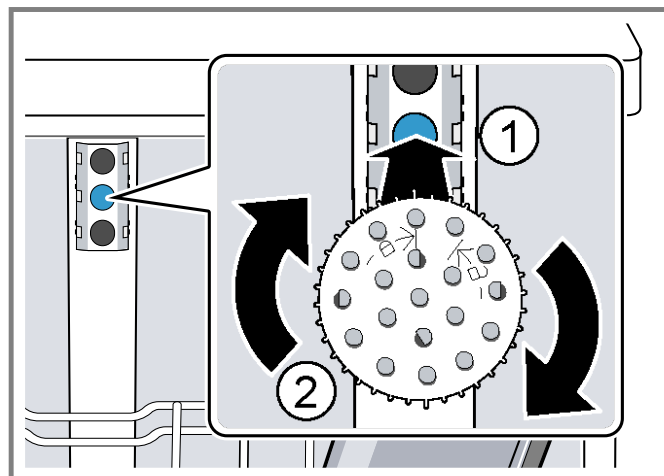

- ✓ The baking sheet spray head clicks into position.

Removing the baking sheet spray head

If you no longer require the baking sheet spray head, remove it from the appliance.

1. Turn the baking sheet spray head to the left and remove from the holder.
2. Insert the upper rack in the appliance.

¹ Depending on the appliance specifications

Appliance height 34" with silverware drawer

Level	Upper rack	Lower rack
1 max. ø	7"	13"
2 max. ø	8"	12"
3 max. ø	9"	11"

8 Before using for the first time

Apply the settings for the first use.

8.1 Initial use

Before the first use, or after a factory reset, you will need to configure the settings.

Tip: Connect your appliance to a mobile device. You can conveniently change all settings using the Home Connect™ app.

→ "Home Connect™ quick start", Page 23

Requirement: The appliance has been installed and connected.

1. Add special salt.
 2. Add rinse aid. → Page 15
 3. Switch on the appliance.
- ✓ The display shows the settings for initial use.
4. Press > repeatedly until the display shows the required setting.

Note: If you select Home Connect™ with the setting Initial use, make further settings using the Home Connect™ app on your mobile device.

You can change the settings for initial use and other Basic settings → Page 22 on the appliance at any time or using the Home Connect™ app on your mobile device.

5. Press — or + repeatedly until the display shows the right value.
You can change one or more settings.
6. To save the settings, press $\frac{i}{P_{3sec}}$ for approx. 3 seconds.
7. Add detergent.
8. Start the Program with the highest cleaning temperature without dishware.

To remove any marks from water or other residues, we recommend you operate the appliance without dishware before using it for the first time.

9 Water softening system

Hard water leaves limescale on dishware as well as the washing tank, and parts of the appliance may become blocked.

To ensure good dishwashing results, you can treat the water with special salt and the water softening system. To avoid damage to the appliance, water with a hardness above 9 °E must be softened.

9.1 Overview of water hardness settings

You can find an overview of the water hardness values that can be selected here.

You can find out how hard your water is from your local water company or by using a water hardness tester.

Water hardness °E	Hardness range	mmol/l	Setting value
0 - 8	soft	0 - 1.1	0 - 8
9 - 10	soft	1.2 - 1.4	9 - 10
11 - 12	medium	1.5 - 1.8	11 - 12
13 - 15	medium	1.9 - 2.1	13 - 15
16 - 20	medium	2.2 - 2.9	16 - 20
21 - 26	hard	3.0 - 3.7	21 - 26
27 - 38	hard	3.8 - 5.4	27 - 38
39 - 62	hard	5.5 - 8.9	39 - 62

Note: Set the water hardness determined on your appliance.

→ "Setting the water softening system", Page 14

With a water hardness of 0 - 8 °E you can dispense with special salt for dishwashers and switch off the water softening system.

→ "Switching off the water softening system", Page 15

9.2 Setting the water softening system

Set the water hardness on your appliance.

1. Determine the water hardness and the appropriate setting value.
→ "Overview of water hardness settings", Page 14
2. Press ON/OFF.
3. To open the basic settings, press $\frac{i}{P_{3sec}}$ for approx. 3 seconds.
4. Press > repeatedly until the display shows "Water hardness".

- Press $-$ or $+$ repeatedly until the right water hardness has been set.

The value 0 - 8 is set at the factory.

- To save the settings, press i for approx. 3 seconds.

9.3 Special Dishwasher Salt

You can use special dishwasher salt to soften the water.

Adding dishwasher salt

If the salt refill indicator lights up, add special dishwasher salt to the dispenser for salt just before the cycle starts. The amount of special dishwasher salt required depends on the water hardness. The higher the water hardness, the greater the amount of salt required.

NOTICE:

Detergent may damage the water softening system.

- ▶ Only fill the dispenser of the water softening system with special dishwasher salt.

Special salt for dishwashers can damage the tub due to corrosion.

- ▶ To make sure that any special salt that escapes is washed out of the tub, add the special salt to the dispenser for special salt immediately before the program starts.

- Unscrew the lid of the salt dispenser and remove.
- Before the first use: Fill the dispenser full with water.
- Note:** Only use special salt specified for dishwashers. Do not use salt tablets. Do not use table salt.

Add the special dishwasher salt to the dispenser.

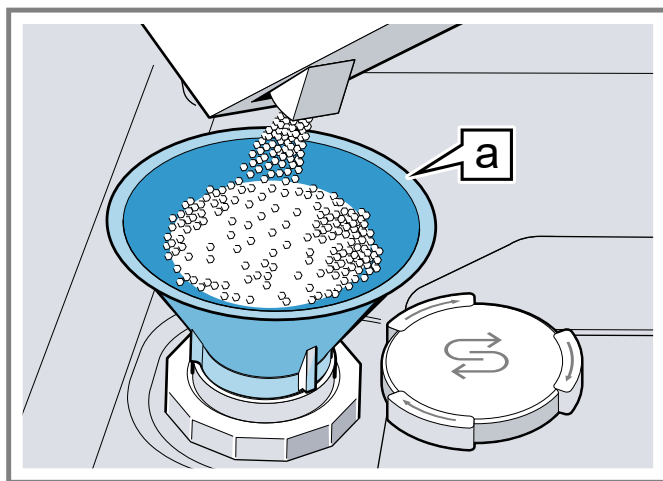

Funnel

Fill the dispenser completely with the salt. The water in the dispenser is displaced and forced out.

- Place the lid back on the dispenser and turn to close.

9.4 Switching off the water softening system

If you do not need to use the water softening system, e.g. you already have a whole house water softening system, you can turn the system off.

Note

To avoid damage to the appliance, only switch off the water softening system in the following cases:

- The water hardness is max. 26 °E and you are using combined detergents with salt replacement substances. According to manufacturers, combined detergents with salt replacement substances can generally only be used up to a water hardness of 26 °E without adding special salt.
- The water hardness is 0 - 8 °E. You can omit special salt.

- Press ON/OFF.
 - To open the basic settings, press i for approx. 3 seconds.
 - Press $>$ repeatedly until the display shows "Water hardness".
 - Press $-$ or $+$ repeatedly until the display shows 0 - 8.
 - To save the settings, press i for approx. 3 seconds.
- ✓ The water softening system is switched off and the salt refill indicator is deactivated.

10 Rinse aid system

You can use the rinse aid system and rinse aid to get dishware and glasses rinsed perfectly without spots.

10.1 Rinse aid

For optimum drying results, use rinse aid.

Only use rinse aid intended for household dishwashers.

Adding rinse aid

If the display shows "Please add rinse aid.", add rinse aid. Only use rinse aid intended for household dishwashers.

- Press the catch on the lid of the dispenser for rinse aid ① and lift ②.

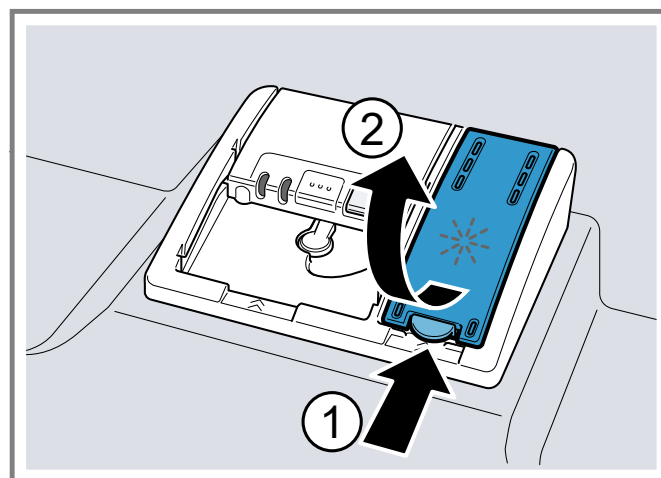

2. Add rinse aid up to the max mark.

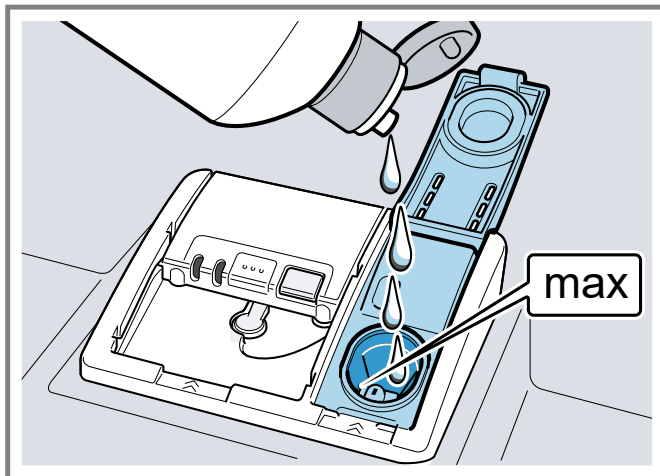

3. If rinse aid spills out, remove it from the tub.
Spilled rinse aid can cause excessive frothing during the wash cycle.
4. Close the lid of the dispenser for rinse aid.
✓ The lid clicks into position.

10.2 Setting the amount of rinse aid

If there are streaks or water spots on dishware, change the amount of rinse aid.

1. Press ON/OFF.
2. To open the basic settings, press $\overset{i}{\text{P}}_{\text{basic}}$ for approx. 3 seconds.
3. Press > repeatedly until the display shows "Rinse aid disp."
4. Press – or + repeatedly until the right amount of rinse aid has been set.
 - A low setting adds less rinse aid during the wash cycle and reduces streaking on dishware.
 - A higher setting adds more rinse aid during the wash cycle, reduces water spots and improves the drying result.
5. To save the settings, press $\overset{i}{\text{P}}_{\text{time}}$ for approx. 3 seconds.

10.3 Switching the rinse aid system off

If you choose not to use rinse aid, you can turn the rinse aid system off.

Tip: Rinse aid within a combination detergent has limited effectiveness. You will generally get better results using a separate rinse aid.

1. Press ON/OFF.
2. To open the basic settings, press $\overset{i}{\text{P}}_{\text{basic}}$ for approx. 3 seconds.
3. Press > repeatedly until the display shows "Rinse aid disp."
4. Press – or + repeatedly until the display shows 0.
5. To save the settings, press $\overset{i}{\text{P}}_{\text{time}}$ for approx. 3 seconds.
✓ The rinse aid system is switched off and the rinse aid refill indicator is deactivated.

11 Detergent

Find out which detergents are suitable for your appliance.

11.1 The correct detergents

Only use detergents that are made for dishwashers, either basic or combination detergents.

For the best washing and drying results, use a separate detergent, then add Special salt and Rinse aid → *Page 15* separately.

Modern, powerful detergents mainly use a low-alkaline formulation with enzymes. Enzymes break down starch and remove protein. Oxygen-based bleaching agents are generally used to remove colored stains, e.g. tea or ketchup.

Note: Follow the manufacturer's instructions for each detergent.

Detergent	Description
Tabs	<p>Tabs are perfect for all cleaning functions and do not need to be measured out.</p> <p>However, with shorter Cycles → <i>Page 9</i> sometimes tabs do not dissolve entirely and leave residues of detergent. This may reduce its effectiveness.</p>
Powder detergent	<p>Powder detergent is recommended for shorter cycles. The dosage can be adjusted to the level of soiling.</p>
Liquid detergent	<p>Liquid detergent works faster and is recommended for shorter cycles without a pre-rinse.</p> <p>Sometimes liquid detergent may leak out despite the detergent dispenser being closed. This is not a problem, just remember the following:</p> <ul style="list-style-type: none"> ■ Only choose a cycle without Pre-Rinse. ■ Do not use the Delay Start option. <p>The dosage can be adjusted to the level of soiling.</p>

11.2 Incompatible detergents

Do not use a detergent which is not designated for dishwasher use or contains chlorine.

Detergent	Description
Liquid hand soap	<p>Liquid hand soap can cause increased frothing and damage the appliance.</p>
Detergent containing chlorine	<p>This may leave chlorine residue on dishware.</p>

11.3 Information on Detergent

Follow the instructions on detergents in everyday use.

- Detergents marked as "ecological" (environmentally friendly) generally contain lower levels of active agents or none at all. The cleaning effect may be reduced.
- Adjust the rinse aid and the water softening system settings in accordance with the detergent or combination detergent in use.

- According to manufacturers, combination detergents with salt replacement substances can only be used up to a certain water hardness, usually 26 °E, without adding special salt. For the best washing and drying results we recommend using special salt from a water hardness of 17 °E.
- Any rinse aid component of a combination detergent has limited effectiveness. You will have better results using a separate rinse aid.
- To prevent sticking, only touch detergents in a water-soluble pouch with dry hands and only ever place them in a dry detergent dispenser.
- Even if the rinse aid and special salt refill indicators light up, the wash cycles will run properly with combination detergents.
- Use tablets with enhanced drying results.

11.4 Adding Detergent

1. To open the detergent dispenser, press the locking latch.
2. Add the detergent to the dry detergent dispenser.

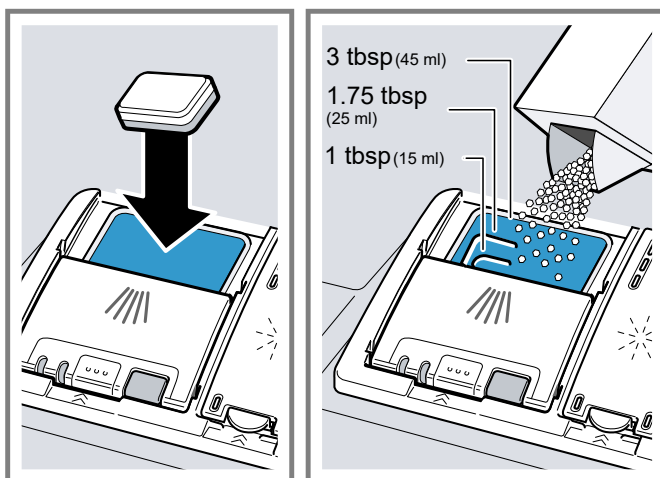

If you are using tablets, one is enough. Insert the tablets in a horizontal position.

If you are using powder or liquid detergent, follow the manufacturer's instructions and quantities for dosage in the detergent dispenser.

1.5 to 1.75 Tbsp (20 ml – 25 ml) detergent is sufficient for normal soiling. If dishware is only lightly soiled, slightly less than the amount of detergent specified is usually sufficient.

3. Close the lid of the detergent dispenser.

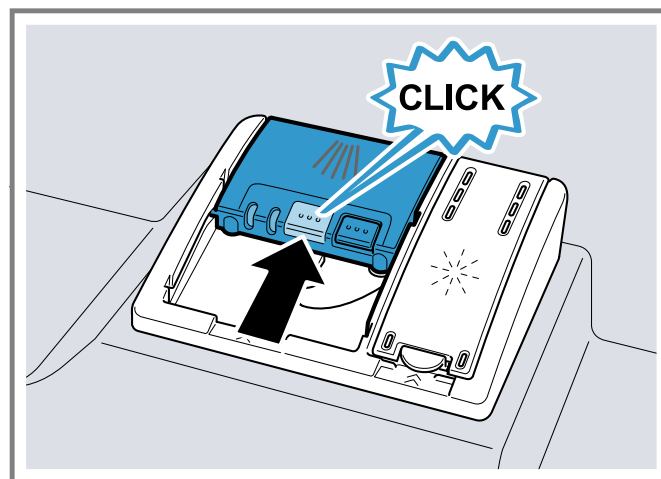

- ✓ The lid clicks into position.
- ✓ The detergent dispenser will open automatically at the optimum time during the cycle. Powder or liquid detergent will spread around the washing tank and dissolve there. Tablets will fall into the tablet collecting tray and dissolve in the right dosage. In order to ensure that tablets can dissolve evenly, do not place any other objects in the tablet collecting tray.

Tip: If you use powder detergent and select a cycle with pre-rinse, you can also add a little detergent to the interior door of the appliance.

11.5 Detergent table

Detergent amount guidelines

Auto 130-150 °F	1.75 Tbsp (25 ml) or 1 tab
Eco	1.75 Tbsp (25 ml) or 1 tab
Glasscare	1 Tbsp (15 ml)
Auto 150-160 °F	3 Tbsp (45 ml) or 1 tab
Quick Wash	1 Tbsp (15 ml)

12 Dishware

Only wash dishware that is suitable for dishwashers.

Note: Decorated glassware and parts made of aluminum or silver may fade or discolor with dishwashing. Delicate types of glass may turn cloudy after a few wash cycles.

12.1 Damage to glass and dishware

Avoid damage to glass and dishware.

Cause	Recommendation
The following dishware is not suitable for dishwashers:	Only put dishware in the dishwasher if it is marked as suitable for dishwashers by the manufacturer.
<ul style="list-style-type: none"> ■ Items of silverware and dishware made from wood ■ Decorated glassware, antique and hand-crafted dishware ■ Plastic dishware not resistant to heat 	

Cause	Recommendation
<ul style="list-style-type: none"> ▪ Dishware made from copper or tin ▪ Dishware soiled with ash, wax, lubricating grease or paint ▪ Very small items of dishware 	
Glass and dishware is not suitable for dishwashers.	Only put glasses and china in the dishwasher if it is marked as suitable for dishwashers by the manufacturer.
The chemical composition of the detergent causes damage.	Use a detergent marked as kind to dishware by the manufacturer.
Highly caustic alkaline or highly acidic cleaning agents, in particular commercial or industrial cleaning agents, are not suitable for dishwashers in conjunction with aluminum.	If you are using highly caustic alkaline or highly acidic cleaning agents, in particular commercial or industrial cleaning agents, do not put aluminum parts inside the dishwasher.
The water temperature of the program is too high.	Select a program with lower temperatures. After the cycle has ended, take glassware and silverware out of the appliance without delay.

12.2 Loading dishware

Arrange dishware correctly to optimize the dishwashing result and prevent damage to both dishware and the appliance.

NOTICE:

Avoid dishwasher damage

- ▶ Do not load the dishwasher with paper products, plastic bags, packing materials or anything other than normal, dishwasher safe dishware and kitchenware.

Tips

- Using the appliance allows you to save energy and water compared to washing-up by hand.
- See our website for examples of how to load your appliance efficiently, free of charge.
- To save energy and water, load the machine with the number of place settings specified.

- For better washing and drying results, position items with curves or recesses at an angle so water can run off.

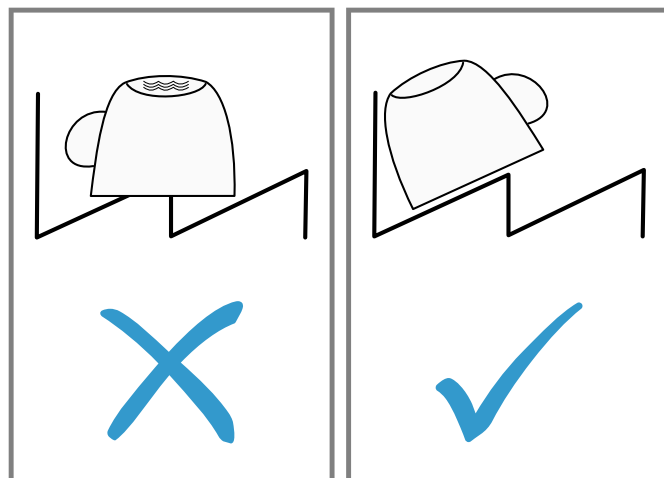

1. Remove large remnants of food from dishware. To save resources, do not pre-rinse dishware under running water.
2. Observe the following when arranging dishware:
 - Put heavily soiled dishware in the lower rack, e.g. pans. The more powerful spray jet ensures that the dishwashing result will be better.
 - To avoid damage to dishware, arrange it so it is stable and cannot tip over.
 - To avoid injury, arrange silverware with the points and sharp edges down.
 - Position containers with the openings facing down so no water can collect in them.
 - Do not block the spray arms - make sure that they can turn freely.
 - Do not place small parts in the collecting tray and do not block it with dishware so as not to obstruct the lid of the detergent dispenser.

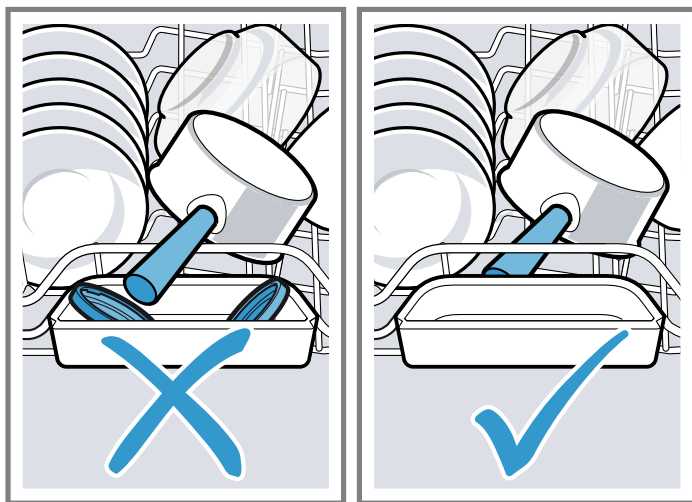

12.3 Removing dishware

⚠ CAUTION

Dishes can be very hot immediately after the cycle ends.

- ▶ Open the door slightly and allow dishes to cool for a few minutes before unloading.

1. To prevent water dripping onto dishware, unload it starting at the bottom and working up.
2. Check the washing tank and accessories for soiling and clean if necessary.
→ "Cleaning and maintenance", Page 24

12.4 Loading patterns

Recommended loading patterns.

12 place settings:

Lower rack

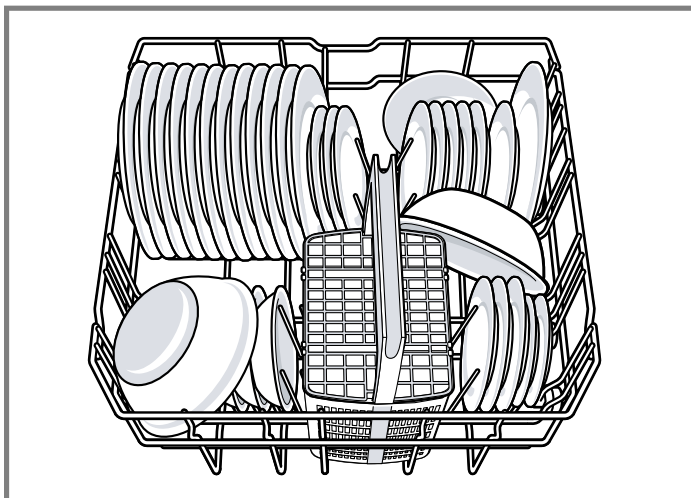

Upper rack

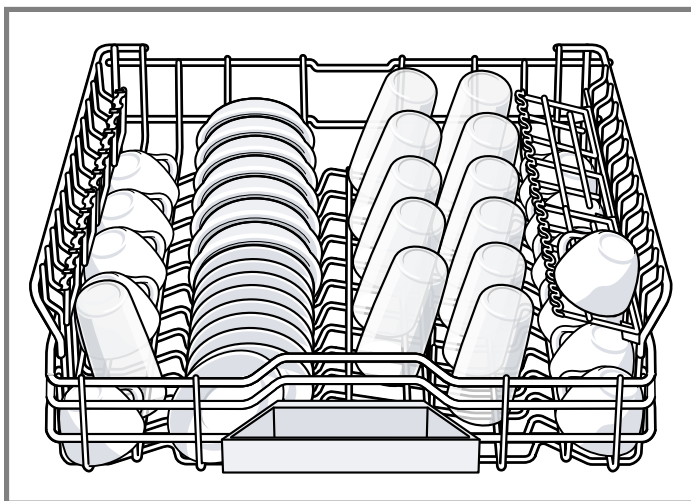

Third rack

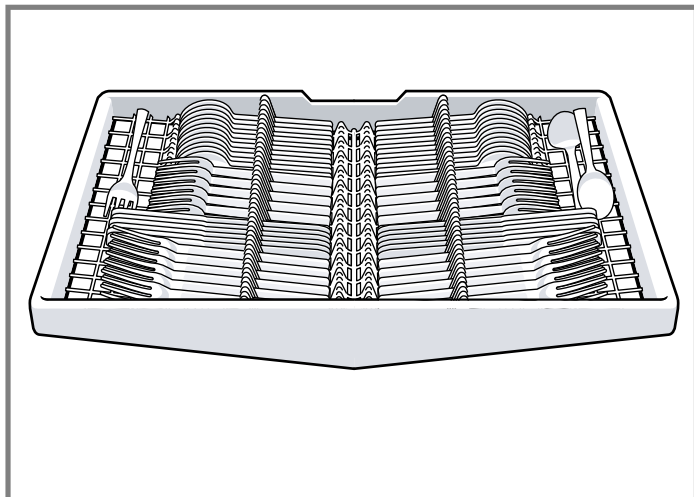

Additional loading patterns for 10 place settings:

Lower rack

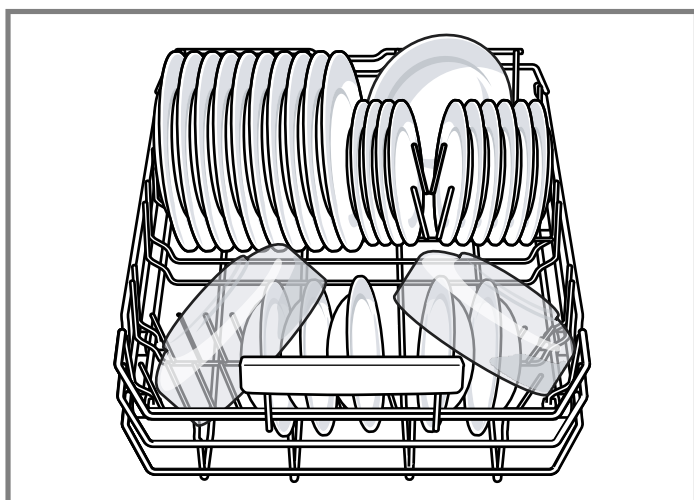

Upper rack

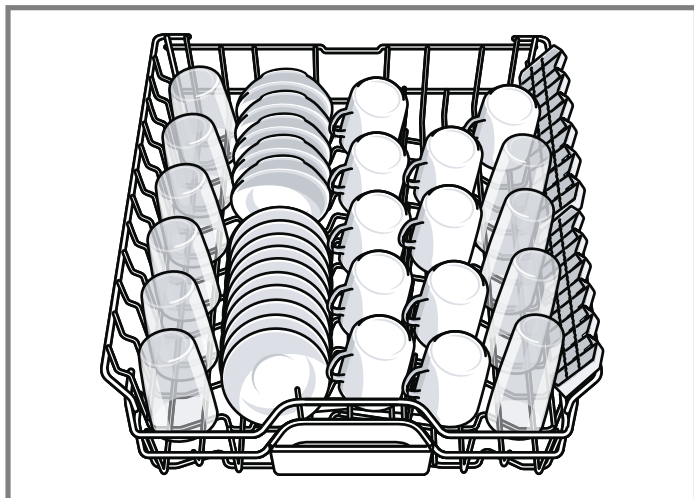

Third rack

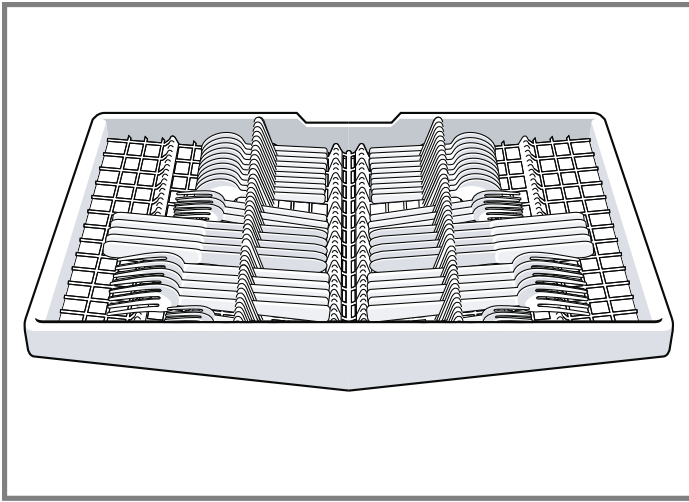

13 Basic Operation

13.1 Protection against unintentional operation

Your appliance is equipped with a function that helps to prevent unintentional operation, e.g. by children. After starting the appliance, the door has to be closed within 4 seconds, otherwise the operation will be paused.

Note: This function cannot be deactivated.

Requirements

- Pressing Start to begin a wash cycle
- Setting Delay time and pressing Start
- Opening the door while Delay time is active
- Opening the door during a wash cycle.

1. Press Start.
 2. Close the door.
- ✓ The wash cycle will resume.

13.2 Opening the appliance door

- ▶ Open the appliance door.

13.3 Switching on the appliance

- ▶ Press ON/OFF.

The standard program is set by default. If you do not perform any actions on the appliance for 10 minutes, it will automatically switch off.

13.4 Setting a cycle

To adjust the wash cycle to the soiling level of the dishware, select a suitable cycle.

- ▶ Press the right cycle button.
- ✓ The cycle is set and the cycle button flashes.

13.5 Setting options

You can set options to complete the chosen cycle.

Note: The available options depend on which cycle is selected.

- ▶ Press the button for the relevant option.
- ✓ The option is set and the option button flashes.

13.6 Setting the electronic delay time

You can delay the start of the wash cycle by up to 24 hours.

1. Press \ominus .
2. Press $-$ or $+$ repeatedly until the display shows the right time.

Depending on the setting of the time display, the end of the program is shown on the display either with "Finish in" (e.g. 3h 25min) or "Finish at" (e.g. 3:20pm). You can change this setting in the Basic settings → *Page 22*.

3. To activate the electronic delay time, press Start.

Note: To deactivate the electronic delay time, press Reset 4 sec. for approx. 4 seconds.

13.7 Starting the wash cycle

- ▶ Press Start.
- ✓ The wash cycle has ended when the display shows "Finished!".

Notes

- If you want to add more dishware while the appliance is running, do not use the collecting tray as a handle for the upper rack. You might touch the partially dissolved tablet.
- You can only change a cycle in progress if you can cancel it first.
→ *"Terminating the wash cycle", Page 20*
- To save energy, the appliance switches off automatically 10 minutes after the end of the wash cycle. If you open the appliance door immediately after the wash cycle has ended, the appliance will switch off after 4 seconds.

13.8 Interrupting the wash cycle

1. Press On/Off.
The program is saved and the appliance switches off.
2. Press On/Off.
3. Press Start to resume the wash cycle.

13.9 Terminating the wash cycle

To end a cycle early or to switch from one that has already started, you will need to cancel it first.

- ▶ Press Reset 4 sec. for approx. 4 seconds.
- ✓ All displays light up.
- ✓ As soon as the displays are off, the display shows "Programme was terminated." and then "Finished!".
- ✓ The cycle is cancelled and ends after approx. 1 minute.

13.10 Displaying wash cycle information

You can show information about cycles and options on the display.

1. Press $\frac{i}{\text{Program}}$.
2. Press the cycle button or an option.

13.11 Switching off the appliance

CAUTION

To avoid risk of injury, always use caution when opening the door during or following a wash cycle as hot water or steam may escape.

- ▶ Do not fully open the door until water noises have stopped and steam has subsided.
1. Please note the information on Preventing Material Damage.
 2. Press On/Off.

14 Basic settings

You can configure your appliance to meet your needs.

14.1 Overview of the basic settings

The basic settings depend on the features of your appliance.



Basic setting	Selection	Description
Time setting	00:00 - 24:00	Set the current time. The setting depends on the time format selected.
Time format	12 h 24 h ¹	Set the time format.
Time display	In hours Time ¹	Set the time display for the end of the wash cycle. "Finish in" shows the remaining time the wash cycle still has to run, e.g. 3h 25min. "Finish at" shows the time when the wash cycle will end, e.g. 3:20pm.
Sprache/Language	See selection on the appliance.	Select the menu language.
Water hardness	0 - 62 0 - 8 ¹	Set the water hardness. → <i>"Overview of water hardness settings", Page 14</i>
Rinse aid disp.	0 - 6 5 ¹	Set or switch off the amount of rinse aid to be dispensed. → <i>"Setting the amount of rinse aid", Page 16</i>
Sensor setting	Standard ¹ Sensitive Very sensitive	Set the water sensor for identifying soiling. → <i>"Sensors", Page 5</i>
Extra Dry	on off ¹	Switch "Extra Dry" on or off for each operation. The temperature is increased during the final rinse for a better drying result. This may increase the run time slightly. Please take care with delicate dishware.
Eco forecast	on off ¹	Switch EcoCheck on or off. When selecting the wash cycle, the average water and energy consumption is briefly shown on the display.
Emotion Light™	off On via main switch ¹ On when opening door	Switch the interior lighting of the appliance on or off. When the appliance door is opened, the interior lighting switches off automatically after 10 minutes.
Infolight®	on ¹ off	Switch "Infolight®" on or off. While the wash cycle is running, a spot of light is projected onto the floor below the appliance door. This light will not be visible if the appliance is installed at eye level with the cabinet front fitted flush. If the appliance door is not completely closed, the spot of light will flash. The wash cycle has ended when the spot of light is no longer visible on the floor.
Start program	Auto 130-150 °F ¹ Prog. last selected	Set a default program for when the appliance is switched on.
Tone volume	Scale with multiple levels.	Set the signal volume at the end of a wash cycle. Level 0 switches the signal tones off.
Button volume	Scale with multiple levels	Set the button volume during operation. Level 0 switches the button tones off.
WLAN	on off	Switch the wireless network connection on or off. The basic setting "WLAN" is not available until you have connected the appliance with the Home Connect™ app. → <i>"Home Connect™", Page 23</i>
Remote Start	off Manual Permanent	Activate or deactivate . The basic setting is not available until you have connected the appliance with the Home Connect™ app. → <i>"Home Connect™", Page 23</i>

¹ Factory setting (may vary according to model)



Basic setting	Selection	Description
Greeting	on ¹ off	Switch display of the brand name logo on or off when the appliance is switched on.
Factory setting	Reset	Restore changed settings to the factory settings. The settings for initial use must be configured.

¹ Factory setting (may vary according to model)

14.2 Changing the basic settings

1. Press ON/OFF.
2. To open the basic settings, press  for approx. 3 seconds.
3. Press > repeatedly until the display shows the required setting.
4. Press — or + repeatedly until the display shows the right value.
You can change one or more settings.
5. To save the settings, press  for approx. 3 seconds.

14.3 Setting the time

1. To open the basic settings, press  for approx. 3 seconds.
2. Press > repeatedly until the display shows "Time setting".
3. Press — or + repeatedly until the display shows the required time.
Holding down — and + will change the set values in 10-minute steps.
4. To save the settings, press  for approx. 3 seconds.

15 Home Connect™

This appliance is network-capable. Connecting your appliance to a mobile device lets you control its functions via the Home Connect™ app.

Home Connect™ services are not available in every country. Availability of the Home Connect™ function depends on the availability of Home Connect™ services in your country. You can find information on this at: www.home-connect.com.

To be able to use Home Connect™, you must first set up the connection to the WLAN home network (Wi-Fi¹) and to the Home Connect™ app.

- → "Connecting appliance to the WLAN home network (Wi-Fi)", Page 23

The Home Connect™ app will guide you through the entire registration process. Follow the instructions in the Home Connect™ app to make the settings.

Tips

- Please consult the Home Connect™ documents supplied.
- Please also note the information in the Home Connect™ app.

Note: Please also note the safety information in this instruction manual and ensure that it is also observed when operating the appliance using the Home Connect™ app.

¹ Wi-Fi is a registered trade mark of the Wi-Fi Alliance.

15.1 Home Connect™ quick start

Connect your appliance to a mobile device quickly and easily.

Installing the app

1. Install the Home Connect™ app on your mobile device.



2. Start the app and set up access for Home Connect™. The Home Connect™ app will guide you through the entire registration process.

Connecting appliance to the WLAN home network (Wi-Fi)

Requirements

- Home Connect™ app is installed on your mobile device.
 - Wi-Fi is activated on the router.
 - The appliance receives signals from the WLAN home network (Wi-Fi) at its installation location.
1. Scan the QR code using the Home Connect™ app.



2. Follow the instructions in the Home Connect™ app.

15.2 Home Connect™ settings

Adapt Home Connect™ to your needs. You can find the Home Connect™ settings in the basic settings for your appliance. Which settings the display shows will depend on whether Home Connect™ has been set up and whether the appliance is connected to your home network.

15.3 Remote start

You can use the Home Connect™ app to start the appliance with your mobile device.

Tip: If you select Remote start → *Page 22* "Permanent" with the basic setting, the remote start function will be permanently activated and you can start your appliance with a mobile device at any time.

Activating remote start

If you have selected remote start "Manual" with the basic setting, you can activate the remote start function on your appliance.

Requirements

- The appliance is connected to your WLAN home network.
 - The appliance is connected to the Home Connect™ app.
 - With the basic setting Remote start → *Page 22*, "Manual" is selected.
 - A program is selected.
- ▶ Press .
- If you open the appliance door, remote start is automatically deactivated.
- ✓ The remote start button flashes.

Tip: To deactivate remote start, press .

15.4 Remote Diagnostics

The Customer Service can access your appliance via Remote Diagnostics if you ask them to do so, if your appliance is connected to the Home Connect™ server and if Remote Diagnostics is available in the country where you are using the appliance.

Tip: Further information and details about the availability of Remote Diagnostics in your country can be found in the Service/Support section of your local website: www.home-connect.com

15.5 Software update

You can use this function to update the software of your appliance, e.g. for optimization, troubleshooting or safety-relevant updates.

The Home Connect™ app informs you about available software updates.

15.6 Data Protection

Please see the information on data protection.

The first time your appliance is registered on a home network connected to the Internet, your appliance will transmit the following types of data to the Home Connect™ server (initial registration):

- Unique appliance identification (consisting of appliance codes as well as the MAC address of the installed Wi-Fi communication module).
- Security certificate of the Wi-Fi communication module (to ensure a secure data connection).
- The current software and hardware version of your appliance.
- Status of any previous reset to factory settings.

This initial registration prepares the Home Connect™ functions for use and is only required when you want to use the Home Connect™ functions for the first time.

Note: Please note that the Home Connect™ functions can be utilized only with the Home Connect™ app. Information on data protection can be called up in the Home Connect™ app.

16 Cleaning and maintenance

To keep your appliance working efficiently for a long time, it is important to clean and maintain it carefully.

16.1 Cleaning the tub

WARNING

Using detergents containing chlorine may result in harm to health.

▶ Never use detergents containing chlorine.

1. Remove any heavy soiling in the interior with a damp cloth.
2. Add detergent to the detergent dispenser.
3. Select the program with the highest temperature.
4. Start the program without dishware. → *Page 20*

16.2 Cleaning agent

Only use suitable cleaning agents to clean your appliance.

16.3 Tips on appliance care

Follow the tips on appliance care to make sure your appliance functions properly at all times.

Action	Benefit
Regularly wipe the door seals, the front of the dishwasher and the control panel using a damp cloth and dishwashing liquid.	This ensures the parts of the appliance will remain clean and hygienic.
If the appliance is not going to be used for a while, leave the door slightly ajar.	This will prevent unpleasant odors.

16.4 Filter system

The filter system removes coarse soiling from the dishwashing cycle.

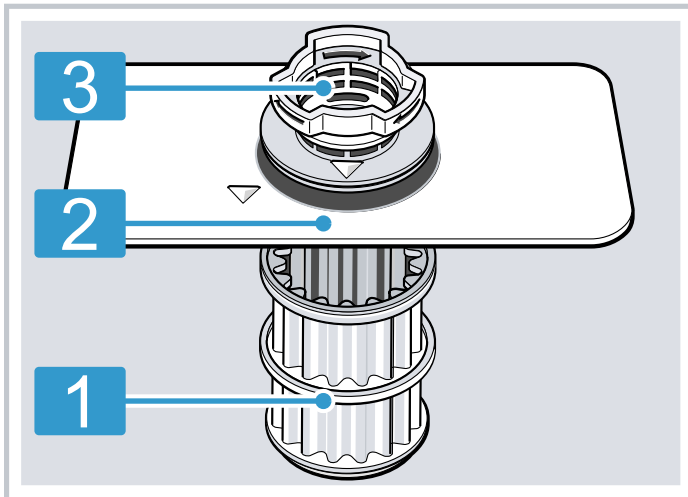

- 1** Micro filter
- 2** Fine filter
- 3** Coarse filter

Cleaning filters

Soiling in the dishwashing water may block the filters.

1. Check the filters for residue after each wash.
2. Turn the coarse filter anticlockwise ① and remove the filter system ②.
 - Make sure that no foreign objects fall into the sump.

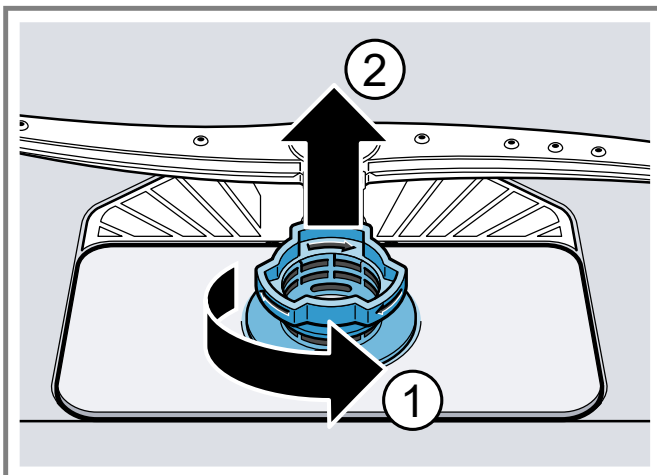

3. Pull down the micro filter to remove.

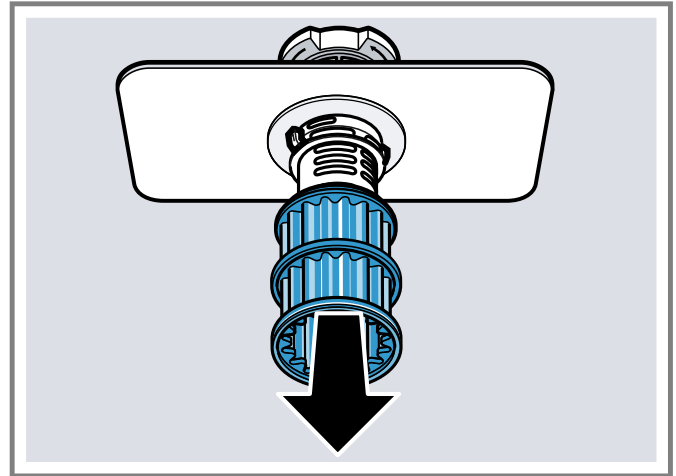

4. Press the locking catches ① together and lift the coarse filter out ②.

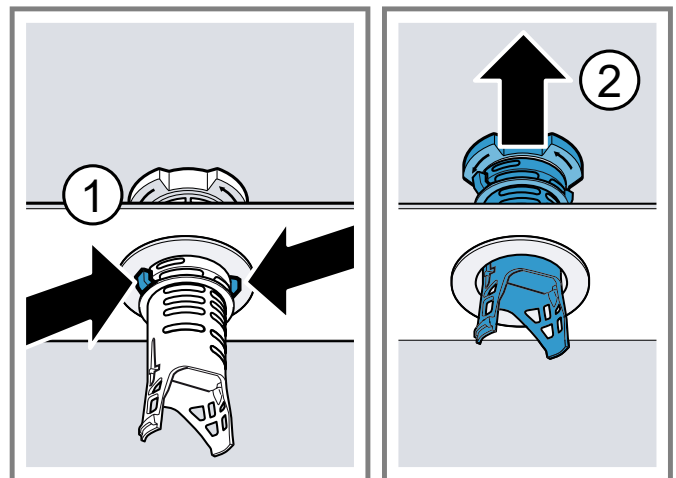

5. Clean the filter elements under running water.
Carefully clean the rim of dirt between the coarse and fine filter.
6. Reassemble the filter system.
Make sure that the locking catches on the coarse filter click into position.
7. Insert the filter system into the appliance and turn the coarse filter clockwise.
Make sure that the arrow markings match up.

16.5 Cleaning the spray arms

Limescale and soiling in the dishwashing water may block the nozzles and bearings on the spray arms. Clean the spray arms regularly.

1. Unscrew the upper spray arm ① and pull down to remove ②.

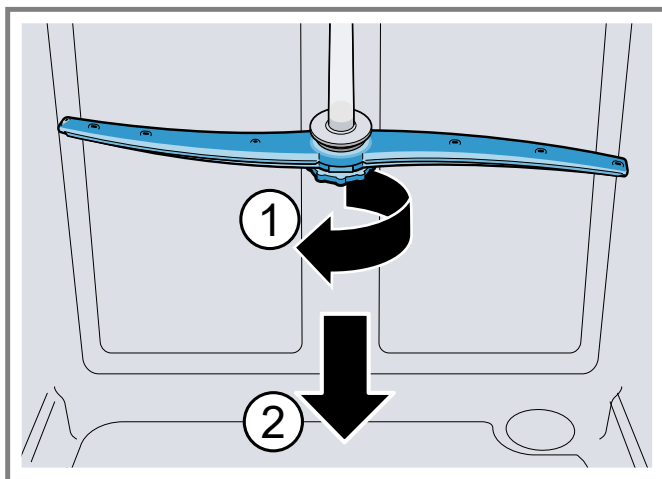

2. Pull up the lower spray arm to remove.

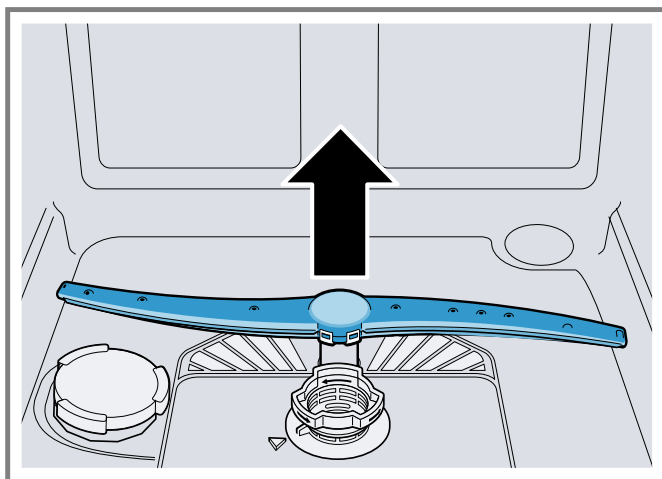

3. Check the outlet nozzles on the spray arms for blockages under running water and remove any foreign objects.
4. Insert the lower spray arm.
 - ✓ The spray arm clicks into position.
5. Insert the upper spray arm and screw firmly in place.

17 Troubleshooting

You can eliminate minor issues on your appliance yourself. Please read the information on eliminating issues before contacting Customer Service. This may avoid unnecessary repair costs.

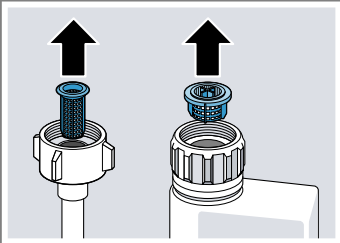
Issue	Cause and troubleshooting
E:2060 lights up.	Appliance has detected that the heating element is calcified. <ol style="list-style-type: none"> 1. Descal the appliance. 2. Operate the appliance with the Water softening system.¹
E:3000 lights up.	Water protection system is activated. <ol style="list-style-type: none"> 1. Turn off the water faucet. 2. Call customer service → <i>Page 34</i>.
E:3100 lights up.	Water protection system is activated. <ol style="list-style-type: none"> 1. Turn off the water faucet. 2. Call customer service → <i>Page 34</i>.
E:3400 lights up.	Water is continuously running into the appliance. <ol style="list-style-type: none"> 1. Turn off the water faucet. 2. Call customer service → <i>Page 34</i>.
E:3200 or indicator for water supply lights up.	Inlet hose is kinked. <ul style="list-style-type: none"> ▶ Install the inlet hose without kinks.
	Water faucet is turned off. <ul style="list-style-type: none"> ▶ Turn on the faucet.
	Water faucet is clogged or calcified. <ul style="list-style-type: none"> ▶ Turn on the faucet. The flow rate must be at least 10 l/min when the water supply is open.
	Filters in the water connection of the supply or AquaStop hose are blocked. <ol style="list-style-type: none"> 1. Switch off the appliance. 2. Pull out the power cord plug. 3. Turn off the water faucet. 4. Unscrew the water connection. 5. Remove the filter from the supply hose.
	
<ol style="list-style-type: none"> 6. Clean the filter. 7. Reinsert the filter in the supply hose. 8. Screw the water connection back on. 9. Check the water connection for leaks. 10. Restore the power supply. 11. Switch the appliance on. 	
E:9240 lights up.	Filters are soiled or blocked. <ul style="list-style-type: none"> ▶ Clean the filters. → <i>"Cleaning filters", Page 25</i>
E:6103 lights up. Water is not draining.	Wastewater hose is blocked or kinked. <ol style="list-style-type: none"> 1. Reposition the wastewater hose without kinks. 2. Remove residues.
	Siphon connection is still sealed. <ul style="list-style-type: none"> ▶ Check the connection to the siphon and open if necessary.

¹ Depending on the appliance specifications

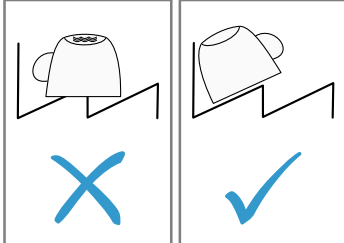
Issue	Cause and troubleshooting
E:6103 lights up. Water is not draining.	Cover of wastewater pump is loose. ▶ Secure the cover of the Wastewater pump → <i>Page 33</i> so it clicks into position.
E:6102 lights up.	Wastewater pump is blocked. ▶ Clean the wastewater pump. → <i>"Clean wastewater pump", Page 33</i>
	Cover of wastewater pump is loose. ▶ Secure the cover of the Wastewater pump → <i>Page 33</i> so it clicks into position.
E:9001 lights up.	Power voltage is too low. There is no problem with the appliance. 1. Call an electrician. 2. Have the power voltage and electrical installation checked by an electrician.
A different error code appears in the display window. E:0100 to E:9010	There is a technical issue. 1. Press ON/OFF. 2. Pull out the power cord plug of the appliance or switch off the breaker. 3. Wait at least 2 minutes. 4. Insert the power cord plug of the appliance in a power outlet or switch on the breaker. 5. Switch the appliance on. 6. If the problem occurs again: – Press ON/OFF. – Turn off the water faucet. – Pull out the power cord plug. – Contact customer service → <i>Page 34</i> and give the error code.
Dishware is not dry.	No rinse aid used or dosage set too low. 1. Add Rinse aid → <i>Page 15</i> . 2. Set the amount of rinse aid to be dispensed. → <i>"Setting the amount of rinse aid", Page 16</i>
	Cycle or cycle option has no drying phase, or drying phase is too short. ▶ Select a wash cycle with drying. → <i>Page 9</i> Some option buttons decrease the drying result.
	Water collects in recesses of dishware or silverware. ▶ Position dishware at an angle where possible.
	
	The combined detergent used has a poor drying performance. 1. Use rinse aid to improve drying performance. 2. Use a different combined detergent with a better drying performance.
	Extra Dry not activated to improve drying performance. ▶ Activate Extra Dry → <i>Page 22</i> .
	Dishware removed too early or drying process not yet ended. 1. Wait until the program ends. 2. Only remove dishware 30 minutes after the program has ended.
	Rinse aid used has a limited drying performance. ▶ Use a name-brand rinse aid. Eco products may have limited effectiveness.
Silverware is not dry.	Silverware not arranged properly in the silverware basket or silverware drawer. Droplets can form on the contact points of silverware. 1. Arrange silverware individually where possible. → <i>Page 18</i> 2. Avoid points of contact.

Issue	Cause and troubleshooting
Appliance interior still wet after wash cycle.	<p>Not an error. Condensation drying creates water droplets in the tub. This is normal. Moisture in the air condenses on the inside walls of the appliance, runs off, and is pumped out. No action required.</p>
Food remnants on dishware.	<p>Dishware was placed too close together or rack is overfilled.</p> <ol style="list-style-type: none"> 1. Arrange dishware with sufficient space in between. The spray jets must reach the surfaces of the dishware. 2. Avoid points of contact.
	<p>Spray arm rotation is blocked.</p> <ul style="list-style-type: none"> ▶ Arrange dishware so it does not obstruct spray arm rotation.
	<p>Spray arm nozzles are blocked.</p> <ul style="list-style-type: none"> ▶ Clean the Spray arms → <i>Page 26</i>.
	<p>Filters are dirty.</p> <ul style="list-style-type: none"> ▶ Clean the filters. → <i>"Cleaning filters", Page 25</i>
	<p>Filters are inserted incorrectly and/or not engaged.</p> <ol style="list-style-type: none"> 1. Insert the filters properly. → <i>"Filter system", Page 25</i> 2. Twist filters into place.
	<p>Selected wash cycle is too light.</p> <ul style="list-style-type: none"> ▶ Select a more intensive cycle. ▶ Adjust the sensitivity of the sensors. → <i>"Sensors", Page 5</i>
	<p>Dishware has been precleaned too intensively. Then the sensors choose a lighter cycle. Stubborn remnants cannot be entirely removed.</p> <ul style="list-style-type: none"> ▶ Only remove large remnants of food and do not pre-rinse dishware. ▶ Adjust the sensitivity of the sensors. → <i>"Sensors", Page 5</i>
Detergent residue in the appliance	<p>Tall narrow containers in corner areas are not rinsed out adequately.</p> <ul style="list-style-type: none"> ▶ Do not position tall narrow containers at too great an angle or in corner areas.
	<p>Upper rack on right and left not set to same height.</p> <ul style="list-style-type: none"> ▶ Set the upper rack on the right and left to the same height.
	<p>Lid of the detergent dispenser is blocked by items of dishware and will not open.</p> <ol style="list-style-type: none"> 1. Arrange dishware in the upper rack so the tab collecting tray is not obstructed by dishware. → <i>"Loading dishware", Page 18</i>
	<p>Items of dishware are blocking the dispenser lid.</p> <ol style="list-style-type: none"> 2. Do not place dishware or fragrance dispensers in the tab collecting tray.
	<p>The lid of the detergent dispenser is blocked by the tab and will not open.</p> <ul style="list-style-type: none"> ▶ Position the tab in the detergent dispenser crosswise, not vertically.
Water spots on plastic parts.	<p>Tabs are used in the quick or short cycle. There is not enough time for the tab to dissolve.</p> <ul style="list-style-type: none"> ▶ Select a more intensive Wash cycle or use Powder detergent.
	<p>Detergent may lose its cleaning or dissolving ability after being stored a long time, or the detergent is clumped together.</p> <ul style="list-style-type: none"> ▶ Change your Detergent.
	<p>Droplet formation on plastic surfaces is unavoidable due to the laws of physics. Water spots are visible after drying.</p> <ul style="list-style-type: none"> ▶ Select a more intensive program. ▶ Position dishware at an angle. → <i>"Loading dishware", Page 18</i>
	<ul style="list-style-type: none"> ▶ Use rinse aid. → <i>"Rinse aid", Page 15</i> ▶ Set the water softening system higher.

Issue	Cause and troubleshooting
Wipeable or water-soluble coatings inside the appliance or on the door.	<p>There is detergent residue. These coatings cannot generally be removed with chemicals.</p> <ul style="list-style-type: none"> ▶ Change your Detergent. ▶ Scrub the appliance by hand.
	<p>White coating is deposited inside the appliance.</p> <ol style="list-style-type: none"> 1. Adjust the water softening system correctly. In most cases you will need to increase the setting. 2. If necessary, change your detergent.
	<p>Special salt dispenser is not screwed tight.</p> <ul style="list-style-type: none"> ▶ Screw the special salt dispenser tight.
There are stubborn white coatings on the dishware, inside the appliance or on the door.	<p>There is detergent residue. These coatings cannot generally be removed with chemicals.</p> <ul style="list-style-type: none"> ▶ Change your Detergent. ▶ Scrub the appliance by hand.
	<p>The hardness range is set incorrectly, or the water hardness is greater than 62 °E (8.9 mmol/l).</p> <ul style="list-style-type: none"> ▶ Set the Water softening system to the water hardness or add special salt.
	<p>3in1/organic/eco detergent is not effective enough.</p> <ul style="list-style-type: none"> ▶ Set the Water softening system to the water hardness and use separate detergents (name brand, special salt, rinse aid).
	<p>Too little detergent is being used.</p> <ul style="list-style-type: none"> ▶ Increase the amount of detergent used or change Detergent .
	<p>Selected wash cycle is too light.</p> <ul style="list-style-type: none"> ▶ Select a more intensive cycle. ▶ Adjust the sensitivity of the sensors. → <i>"Sensors", Page 5</i>
Tea residue or lipstick marks on dishware.	<p>Dishwashing temperature is too low.</p> <ul style="list-style-type: none"> ▶ Select a program with a higher dishwashing temperature.
	<p>Too little detergent is being used or is unsuitable.</p> <ul style="list-style-type: none"> ▶ Use a suitable Detergent and follow the manufacturer's instructions for the amount to be used.
	<p>Dishware has been precleaned too intensively. Then the sensors choose a lighter cycle. Stubborn remnants cannot be entirely removed.</p> <ul style="list-style-type: none"> ▶ Only remove large remnants of food and do not pre-rinse dishware. ▶ Adjust the sensitivity of the sensors. → <i>"Sensors", Page 5</i>
There are colored coatings (blue, yellow, brown) inside the appliance or on stainless steel dishware that are difficult or impossible to remove.	<p>The formation of films is due to substances contained in vegetables (cabbage, celery, potatoes, noodles, etc.) or tap water (manganese).</p> <ul style="list-style-type: none"> ▶ Clean the appliance. <p>You can remove coatings with Mechanical cleaning → <i>Page 24</i> or a machine cleaning product. It may not always be possible to completely remove coatings but they are harmless to health.</p>
	<p>The formation of films is due to metal components on silver or aluminum dishware.</p> <ul style="list-style-type: none"> ▶ Clean the appliance. <p>You can remove coatings with Mechanical cleaning → <i>Page 24</i> or a machine cleaning product. It may not always be possible to completely remove coatings but they are harmless to health.</p>
There are colored deposits (yellow, orange, brown) that are easy to remove inside the appliance (mainly at the bottom).	<p>The formation of films is due to ingredients of food remnants and tap water (limescale), "soaplike".</p> <ol style="list-style-type: none"> 1. Check the setting of the water softening system. 2. Add special salt. 3. If you are using combined detergents (tabs), activate the water softening system. Follow the information on detergents.
Plastic parts inside the appliance are discolored.	<p>Plastic parts inside the appliance may become discolored over the life of the dishwasher.</p> <ul style="list-style-type: none"> ▶ Discoloration may come about and will not impair functioning of the appliance.

Issue	Cause and troubleshooting
Plastic parts are discolored.	<p>Dishwashing temperature is too low.</p> <ul style="list-style-type: none"> ▶ Select a program with a higher dishwashing temperature. <hr/> <p>Dishware has been precleaned too intensively. The sensors then choose a weaker program. Stubborn soiling cannot be entirely removed.</p> <ul style="list-style-type: none"> ▶ Only remove large remnants of food and do not prerinse dishware. ▶ Adjust the sensitivity of the sensors. <p>→ "Sensors", Page 5</p>
There are removable streaks on glasses, glassware with a metallic appearance and silverware.	<p>Amount of rinse aid to be dispensed is set too high.</p> <ul style="list-style-type: none"> ▶ Set the rinse aid system to a lower setting. <hr/> <p>No rinse aid has been added.</p> <ul style="list-style-type: none"> ▶ → "Adding rinse aid", Page 15 <hr/> <p>There is detergent residue in the final rinse. Lid of detergent dispenser is blocked by dishware and will not open fully.</p> <ol style="list-style-type: none"> 1. Arrange dishware in the upper rack so the tab collecting tray is not obstructed by dishware. <ul style="list-style-type: none"> → "Loading dishware", Page 18 Items of dishware are blocking the dispenser lid. 2. Do not place dishware or fragrance dispensers in the tab collecting tray. <hr/> <p>Dishware has been precleaned too intensively. Then the sensors choose a lighter cycle. Stubborn remnants cannot be entirely removed.</p> <ul style="list-style-type: none"> ▶ Only remove large remnants of food and do not pre-rinse dishware. ▶ Adjust the sensitivity of the sensors. <p>→ "Sensors", Page 5</p>
Irreversible clouding of glassware.	<p>Glasses are not dishwasher-proof, only suitable for dishwashers.</p> <ul style="list-style-type: none"> ▶ Use dishwasher-proof glasses. <p>Glasses are usually only suitable for cleaning in a dishwasher, i.e. long-term wear or long-term changes must be expected.</p> <ul style="list-style-type: none"> ▶ Avoid a lengthy steam phase (standing time after wash cycle ends). ▶ Use a program with a lower temperature. ▶ Set the softening system to the water hardness. ▶ Use detergent with a glass protection component.
Detergent residue is present in the detergent dispenser or the tab collecting tray.	<p>Spray arms were blocked by dishware so detergent was not rinsed out.</p> <ul style="list-style-type: none"> ▶ Check that the spray arms are not blocked and can rotate freely. <hr/> <p>Detergent dispenser was damp when detergent was added.</p> <ul style="list-style-type: none"> ▶ Only add detergent to the detergent dispenser when dry.
Excessive formation of foam occurs.	<p>Hand soap got in the rinse aid dispenser.</p> <ul style="list-style-type: none"> ▶ Immediately add rinse aid to the dispenser. <p>→ "Adding rinse aid", Page 15</p> <hr/> <p>Rinse aid has been spilled.</p> <ul style="list-style-type: none"> ▶ Remove the rinse aid with a cloth. <hr/> <p>Detergent or machine care product used causes excessive foaming.</p> <ul style="list-style-type: none"> ▶ Change the brand of detergent.
Connection to home network is not established.	<p>WLAN on router is not active.</p> <ul style="list-style-type: none"> ▶ Check the wireless network connection of your router.
WLAN display is flashing.	<p>Connection to home network is not available.</p> <ul style="list-style-type: none"> ▶ Activate the wireless network connection on your router.
Home Connect cannot be implemented correctly.	<p>Home Connect set incorrectly.</p> <ul style="list-style-type: none"> ▶ Please consult the documents supplied for Home Connect. <hr/> <p>There is a technical error.</p> <ul style="list-style-type: none"> ▶ Please consult the information on support in the documents supplied for Home Connect.
Special salt refill indicator lights up.	<p>Insufficient special salt.</p> <ul style="list-style-type: none"> ▶ Add Special salt. <hr/> <p>Sensor does not detect special salt tablets.</p> <ul style="list-style-type: none"> ▶ Do not use special salt tablets.

Issue	Cause and troubleshooting
Refill indicator for special salt does not light up.	Water softening system is switched off. ▶ Adjust water softening system
Refill indicator for rinse aid lights up.	No rinse aid. 1. Add Rinse aid → <i>Page 15</i> . 2. Set the amount of rinse aid to be dispensed. → <i>"Setting the amount of rinse aid", Page 16</i>
Refill indicator for rinse aid does not light up.	Rinse aid system is switched off. ▶ Set the amount of rinse aid.
Water is left in the appliance at the end of the program.	Filter system or area under the filters is blocked. 1. Clean the Filters → <i>Page 25</i> . 2. Clean the Wastewater pump → <i>Page 33</i> . Program has not yet ended. ▶ Wait until the program ends or terminate the program with Reset . ▶ → <i>"Terminating the wash cycle", Page 20</i>
Appliance cannot be switched on or operated.	Software update is taking place. ▶ Wait until the software update has finished. Appliance functions have failed. 1. Pull out the power cord plug or switch off the breaker. 2. Wait at least 2 minutes. 3. Connect the appliance to the power supply. 4. Switch the appliance on.
Appliance does not start.	The breaker has tripped. ▶ Check the relevant breaker. Power cord is not inserted. 1. Check whether the power outlet is working. 2. Check whether the power cord plug is properly inserted in the power outlet and on the rear of the appliance. Appliance door is not closed properly. ▶ Close the appliance door.
Wash cycle starts up automatically.	You did not wait until the cycle ended. ▶ → <i>"Terminating the wash cycle", Page 20</i>
Appliance stops during the cycle or cuts out.	Appliance door is not closed properly. ▶ Close the appliance door. Power and/or water supply has been interrupted. 1. Check the power supply. 2. Check the water supply. Upper rack is pressing against inner door and preventing appliance door from being closed securely. ▶ Check whether the rear panel of the appliance is being pressed in by a power outlet or a hose holder that has not been removed. ▶ Arrange the dishware so that no parts project beyond the rack and prevent the appliance door from closing properly.
Appliance door cannot be closed.	Door lock has been activated. ▶ Close the appliance door with greater force. Door cannot be closed due to installation method. ▶ Check whether the appliance has been installed properly. When closed, the appliance door, its decor or attached parts should not knock against adjacent cabinets or the worktop.
Lid on the detergent dispenser cannot be closed.	Detergent dispenser or lid are blocked by sticky detergent residue. ▶ Remove detergent residue.
Filling valves making knocking noises.	Caused by the domestic installation. No fault present in the appliance. Does not affect functioning of the appliance. ▶ Can only be remedied in the home installation.

Issue	Cause and troubleshooting
Knocking or rattling noise.	Spray arm is striking dishes. ▶ Arrange dishware so the spray arms do not strike dishware.
	With a small load the water jets directly strike against the tub. ▶ Distribute the dishware evenly. ▶ Load the appliance with more dishware.
	Light items of dishware move about during the wash cycle. ▶ Position light items of dishware securely.

17.1 Clean wastewater pump

Large food remnants or foreign objects can block the wastewater pump. As soon as the dishwashing water no longer drains properly, the wastewater pump must be cleaned.

⚠ CAUTION

There may be some sharp debris, such as glass fragments, blocking the wastewater pump.

▶ Use caution when removing parts for cleaning.

1. Disconnect the appliance from the power supply.
2. Remove the upper and lower rack.
3. Remove the filter system.
4. Scoop out any water.
Use a sponge if necessary.
5. Prise off the pump cover using a spoon and grip it by the crosspiece.

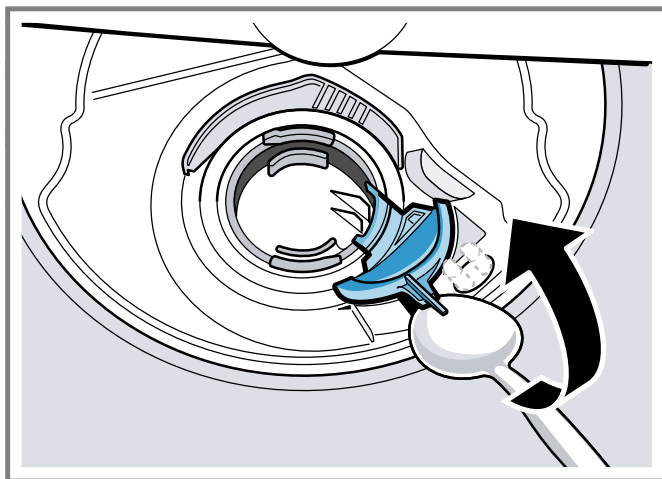

6. Lift the pump cover inwards at an angle and remove.
7. Remove any food remnants or foreign objects in the area of the impeller.

8. Insert the pump cover ① and press down ②.

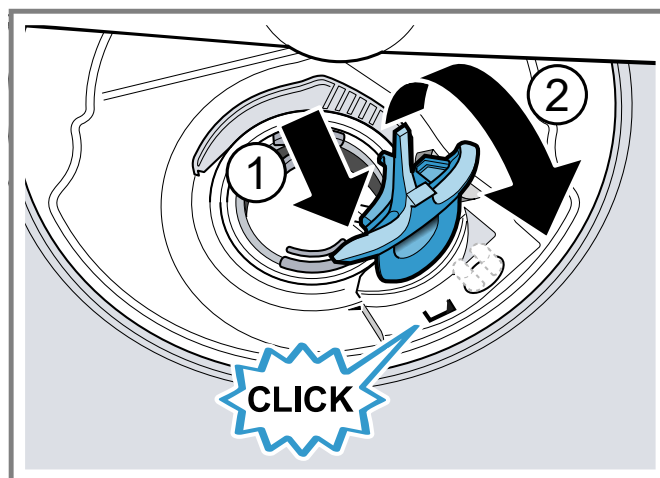

✓ The pump cover clicks into position.

9. Install the filter system.
10. Insert the upper and lower rack.

18 Transportation, storage and disposal

Here you will find out how to prepare your appliance for transportation and storage. You will also find out how to dispose of old appliances.

18.1 Removing the appliance

1. Disconnect the appliance from the power supply.
2. Turn off the water faucet.
3. Detach the drain connection.
4. Detach the drinking water connection.
5. Loosen any screws fastening the appliance to cabinet parts.
6. Remove the base panel if fitted.
7. Pull the appliance out carefully, along with the hose behind it.

18.2 Vacation and Storage

NOTICE:

Preparing your unit for vacation

- ▶ Before leaving for vacation during warmer weather, besides turning off the main valve, also turn off water supply at the nearest point to the dishwasher. During colder weather, please follow the instructions for winterizing your unit below.

Winterizing your unit

- ▶ If your dishwasher will be unused for an extended period of time in a location that experiences freezing temperatures (vacation home or through a vacation period), have your dishwasher winterized by an authorized professional service.

18.3 Transporting the appliance

To avoid damage to the appliance, empty it before transporting.

Note: Always transport the dishwasher upright to prevent residual water getting into the machine's controls and damaging the appliance.

1. Remove dishware from the appliance.
2. Secure loose parts.
3. Switch on the appliance. → *Page 20*
4. Select the program with the highest temperature.
5. Start the wash cycle. → *Page 20*
6. To drain the appliance, terminate the wash cycle after approx. 4 minutes.
→ *"Terminating the wash cycle", Page 20*
7. Switch off the appliance.
8. Turn off the water faucet.
9. To empty the residual water out of the appliance, detach the supply hose and let the water drain out.

18.4 Disposal of your old appliance

Environmentally sound disposal allows valuable raw materials to be recycled.

WARNING

Avoid a risk of entrapment upon disposal.

- ▶ Unplug the appliance from the power outlet.
- ▶ Cut the power cord and remove the door upon discarding the appliance.
- ▶ Check your local area for large appliance recycling programs.

19 Customer service

If you have any questions, are unable to eliminate an issue in the appliance yourself, or the appliance needs to be repaired, please contact our Customer Service.

We will work to find an appropriate solution for you thereby avoiding unnecessary visits by a service provider.

With any warranty repair, we will make sure your appliance is repaired by a trained authorized service provider using genuine replacement parts. We use only genuine replacement parts for all repairs.

Detailed information on the warranty period and terms of warranty can be found in the Statement of Limited Product Warranty, from your retailer, or on our website.

If you contact the Customer Service, you will require the model number (E-Nr.), the production number (FD) and the consecutive numbering (Z-Nr.) of your appliance.

USA:

1-877-442-4436

www.gaggenau.com

www.gaggenau.com/zz/store

CA:

1-877-442-4436

www.gaggenau.com

www.gaggenau.ca

For assistance with connecting to Home Connect™, you can also view instructions here:

www.home-connect.com/us/en/help-support/set-up

19.1 Model number (E-Nr.), production number (FD) and consecutive numbering (Z-Nr.)

You can find the model number (E-Nr.), the production number (FD) and the consecutive numbering (Z-Nr.) on the appliance's rating plate.

The rating plate is located inside the appliance door.

Making a note of your appliance's details and the Customer Service telephone number will enable you to find them again quickly.

19.2 AquaStop® Pledge

In addition to the standard warranty provided by BSH, BSH will also compensate customers for damage caused by a specific fault in the AquaStop system giving rise to a valid warranty claim. Compensation will be provided under the following conditions:

- If water damage is caused by a defect in materials or workmanship in the AquaStop system, BSH will compensate customers reasonable and verifiable damages.
- A condition of all warranty claims is the appliance with AquaStop must have been installed and connected correctly in accordance with all instructions; this also includes a properly installed AquaStop extension (genuine accessories). The warranty does not cover defective feed lines or fittings leading to the AquaStop connection at the tap.

20 Technical specifications

Facts and figures for your appliance can be found here.

Weight	Max.: 60 kg
Voltage	120 V, 50 Hz or 60 Hz
Power rating	1440 W
Fuse	12 A
Water pressure	<ul style="list-style-type: none"> ■ Min. 7.25 psi (50 kPa) ■ Max. 145 psi (1000 kPa)
Inlet rate	Min. 2.6 gal/min
Water temperature	Cold water. Hot water max.: 140 °F/ (60 °C)
Load capacity	13 place settings

20.1 Information regarding Free and Open Source Software

This product includes software components that are licensed by the copyright holders as free software or open source software.

The applicable license information is stored on your home appliance. You can also access the applicable license information via your Home Connect App: "Profile -> Legal information -> License Information". You can download the license information on the brand product website (search for your appliance model on the product website and check additional documents). Alternatively, you can send a request to ossrequest@bshg.com or to BSH Hausgeräte GmbH, Carl-Wery-Str. 34, D-81739 München, Germany.

The source code will be made available to you on request. To file a request, please email to ossrequest@bshg.com or send a written request to BSH Hausgeräte GmbH, Carl-Wery-Str. 34, D-81739 München, Germany. Reference: "OSSREQUEST"

The cost of performing your request will be charged to you. This offer is valid three years from the date of purchase or at least as long as we offer support and spare parts for the respective appliance.

21 Statement of Limited Product Warranty

21.1 What this Warranty Covers & Who it Applies to

The limited warranty provided by BSH Home Appliances ("BSH") in this Statement of Limited Product Warranty applies only to the BSH appliance sold to you ("Product"), provided that the Product was purchased:

- For your normal, household (non-commercial) use, and has in fact at all times only been used for normal household purposes.
- New at retail (not a display, "as is", or previously returned model), and not for resale, or commercial use.
- Within the United States or Canada, and has at all times remained within the country of original purchase.

The warranties stated herein apply to the original purchaser of the product warranted herein and to each succeeding owner of the product purchased for ordinary home use during the term of the warranty.

Please make sure to return your registration card; while not necessary to effectuate warranty coverage, it is the best way for BSH to notify you in the unlikely event of a safety notice or product recall.

21.2 How Long the Warranty Lasts

BSH warrants that the Product is free from defects in materials and workmanship for a period of three hundred sixty-five (365) days from the date of the original purchase. The foregoing timeline begins to run upon the date of the original purchase, and shall not be stalled, tolled, extended, or suspended, for any reason whatsoever. This Product is also warranted to be free from cosmetic defects in material and workmanship (such as scratches of stainless steel, paint/porcelain blemishes, chip, dents, or other damage to the finish) of the Product, for a period of thirty (30) days from the date of purchase or closing date for new construction. This cosmetic warranty excludes slight color variations due to inherent differences in painted and porcelain parts, as well as differences caused by kitchen lighting, product location, or other similar factors. This cosmetic warranty specifically excludes any display, floor, "As Is", or "B" stock appliances.

21.3 Extended Warranty

BSH also provides these additional limited warranties:

- 5 year limited warranty on electronics: BSH will repair or replace any BSH microprocessor or printed circuit board if it proves to be defective in materials or workmanship (excludes labor charges).
- 5 year limited warranty on dish racks: BSH will replace the upper or lower dish rack (excluding rack components), if the rack proves defective in materials or workmanship (excludes labor charges).
- Lifetime warranty against stainless steel rust through: BSH will repair or replace your dishwasher with the same model or a current model that is substantially equivalent or better in functionality, if the inner liner should rust through (excludes labor charges).
- BSH will repair or replace the stainless steel door if the door should rust through (excludes labor charges).

21.4 Repair/Replace as Your Exclusive Remedy

During this warranty period, BSH or one of its authorized service providers will repair your Product without charge to you (subject to certain limitations stated herein) if your Product proves to have been manufactured with a defect in materials or workmanship. If reasonable attempts to repair the Product have been made without success, then BSH will replace your Product (upgraded models may be available to you, in BSH's sole discretion, for an additional charge). Nothing in this warranty requires damaged or defective parts to be replaced with parts of a different type or design than the original part. All removed parts and components shall become the property of BSH at its sole option. All replaced and/or repaired parts shall assume the identity of the original part for purposes of this warranty and this warranty shall not be extended with respect to such parts. BSH's sole liability and responsibility hereunder is to repair manufacturer-defective Product only, using a BSH authorized service provider during normal business hours. For safety and property damage concerns, BSH highly recommends that you do not attempt to repair the Product yourself, or use a non-authorized service provider; BSH will have no responsibility or liability for repairs or work performed by a non-authorized service provider. Authorized service providers are those persons or companies that have been specially trained on BSH products, and who possess, in BSH's opinion, a superior reputation for customer service and technical ability (note that they are independent entities and are not agents, partners, affiliates or representatives of BSH). Notwithstanding the foregoing, BSH will not incur any liability, or have responsibility, for the Product if it is located in a remote area (more than 100 miles from an authorized service provider) or is reasonably inaccessible, hazardous, threatening, or treacherous locale, surroundings, or environment; in any such event, if you request, BSH would still pay for labor and parts and ship the parts to the nearest authorized service provider, but you would still be fully liable and responsible for any travel time or other special charges by the service company, assuming they agree to make the service call.

21.5 Out of Warranty Product

BSH is under no obligation, at law or otherwise, to provide you with any concessions, including repairs, prorates, or Product replacement, once this warranty has expired.

21.6 Warranty Exclusions

The warranty coverage described herein excludes all defects or damage that are not the direct fault of BSH, including without limitation, one or more of the following:

- Use of the Product in anything other than its normal, customary and intended manner (including without limitation, any form of commercial use, use or storage of an indoor product outdoors, use of the Product in conjunction with air or water-going vessels).
- Any party's willful misconduct, negligence, misuse, abuse, accidents, neglect, improper operation, failure to maintain, improper or negligent installation, tampering, failure to follow operating instructions, mishandling, unauthorized service (including selfperformed "fixing" or exploration of the appliance's internal workings).
- Adjustment, alteration or modification of any kind.

- A failure to comply with any applicable state, local, city, or county electrical, plumbing and/or building codes, regulations, or laws, including failure to install the product in strict conformity with local fire and building codes and regulations.
- Ordinary wear and tear, spills of food, liquid, grease accumulations, or other substances that accumulate on, in, or around the Product.
- Any external, elemental and/or environmental forces and factors, including without limitation, rain, wind, sand, floods, fires, mud slides, freezing temperatures, excessive moisture or extended exposure to humidity, lightning, power surges, structural failures surrounding the appliance, and acts of God.
- Service calls to correct the installation of your Product, to instruct you how to use your Product, to replace house fuses or correct house wiring or plumbing.
- Removal and replacement of trim or decorative panels that interfere with servicing the Product.
- Damage or defects caused by labor or parts installed by any non-authorized service provider, unless approved by BSH before service is performed.

In no event shall BSH have any liability or responsibility whatsoever for damage to surrounding property, including cabinetry, floors, ceilings, and other structures or objects around the Product. Also excluded from this warranty are Products, on which the serial numbers have been altered, defaced, or removed; service visits to teach you how to use the Product, or visits where there is nothing wrong with the Product; correction of installation problems (you are solely responsible for any structure and setting for the Product, including all electrical, plumbing or other connecting facilities, for proper foundation/flooring, and for any alterations including without limitation cabinetry, walls, floors, shelving, etc.); and resetting of breakers or fuses TO THE EXTENT ALLOWED BY LAW, THIS WARRANTY SETS OUT YOUR EXCLUSIVE REMEDIES WITH RESPECT TO PRODUCT, WHETHER THE CLAIM ARISES IN CONTRACT OR TORT (INCLUDING STRICT LIABILITY, OR NEGLIGENCE) OR OTHERWISE. THIS WARRANTY IS IN LIEU OF ALL OTHER WARRANTIES, WHETHER EXPRESS OR IMPLIED. ANY WARRANTY IMPLIED BY LAW, WHETHER FOR MERCHANTABILITY OR FITNESS FOR A PARTICULAR PURPOSE, OR OTHERWISE, SHALL BE EFFECTIVE ONLY FOR THE PERIOD THAT THIS EXPRESS LIMITED WARRANTY IS EFFECTIVE. IN NO EVENT WILL THE MANUFACTURER BE LIABLE FOR CONSEQUENTIAL, SPECIAL, INCIDENTAL, INDIRECT, "BUSINESS LOSS", AND/OR PUNITIVE DAMAGES, LOSSES, OR EXPENSES, INCLUDING WITHOUT LIMITATION TIME AWAY FROM WORK, HOTELS AND/OR RESTAURANT MEALS, REMODELLING EXPENSES IN EXCESS OF DIRECT DAMAGES WHICH ARE DEFINITELY CAUSED EXCLUSIVELY BY BSH, OR OTHERWISE. SOME STATES DO NOT ALLOW THE EXCLUSION OR LIMITATION OF INCIDENTAL OR CONSEQUENTIAL DAMAGES, AND SOME STATES DO NOT ALLOW LIMITATIONS ON HOW LONG AN IMPLIED WARRANTY LASTS, SO THE ABOVE EXCLUSIONS OR LIMITATIONS MAY NOT APPLY TO YOU. THIS WARRANTY GIVES YOU SPECIFIC LEGAL RIGHTS, AND YOU MAY ALSO HAVE OTHER RIGHTS WHICH VARY FROM STATE TO STATE.

No attempt to alter, modify or amend this warranty shall be effective unless authorized in writing by an officer of BSH.

21.7 Obtaining Warranty Service - GG

To obtain warranty service for your product, you should contact Gaggenau Customer Support at 1-877-442-4436 to schedule a repair.

Model: SMB
FCC ID: 2AHES-SMB
IC: 21152-SMB

The Home Connect module is a communication device designed to provide communication between appliances and smart devices.

This module is integrated at the factory, under direct control of B/S/H Home Appliances Corporation, and is not user serviceable or upgradable. At least 20cm separation distance should be maintained from device to user.

FCC COMPLIANCE STATEMENT

CAUTION: Changes or modifications not expressly approved could void your authority to use this equipment.

This device complies with Part 15 of the FCC Rules. Operation to the following two conditions (1) This device may not cause harmful interference, and (2) this device must accept any interference received, including interference that may cause undesired operation.

INDUSTRY CANADA STATEMENT

This device complies with Industry Canada licence-exempt RSS standard(s). Operation is subject to the following two conditions: (1) this device may not cause interference, and (2) this device must accept any interference, including interference that may cause undesired operation of the device.

Operation in the band 5150-5250 MHz is only for indoor use to reduce the potential for harmful interference to co-channel mobile satellite systems.

Le présent appareil est conforme aux CNR d'Industrie Canada applicables aux appareils radio exempts de licence. L'exploitation est autorisée aux deux conditions suivantes : (1) l'appareil ne doit pas produire de brouillage, et (2) l'utilisateur de l'appareil doit accepter tout brouillage radioélectrique subi, même si le brouillage est susceptible d'en compromettre le fonctionnement.

La bande 5 150-5 250 MHz est réservée uniquement pour une utilisation à l'intérieur afin de réduire les risques de brouillage préjudiciable aux systèmes de satellites mobiles utilisant les mêmes canaux.

BSH Home Appliances Corporation

1901 Main Street, Suite 600

Irvine, CA 92614

USA

www.gaggenau.com

1-877-442-4436

© 2021 BSH Home Appliances Corporation

GAGGENAU



9001630006 en-us (010305) 650 P5