

de Montageanleitung
 *) über Kundendienst erhältlich
en Installation instructions
 *) Available from customer service
fr Notice de montage
 *) Disponible par le biais du service après-vente
nl Montagevoorschrift
 *) Tegen meerprijs bij de Servicedienst verkrijgbaar
it Istruzioni per il montaggio
 *) Disponibili presso il servizio assistenza clienti
el Οδηγίες τοποθέτησης
 *) Διαθέσιμα από τη υπηρεσία τεχνικής (υποστήριξης) κλιμακωτά
es Instrucciones de montaje
 *) Se puede adquirir a través del Servicio de Asistencia Técnica Oficial de la marca
pt Instruções de montagem
 *) Pode ser adquirido nos nossos Serviços Técnicos
sv Monteringsanvisning
 *) kan fås via Service

tr Montaj kılavuzu
 *) Yetkili servis üzerinden alınabilir
ru Инструкция по монтажу
 *) Можно получить в сервисном центре
cs Montážní návod
 *) K dispozici přes servisní službu
no Monteringsanvisning
 *) fåes hos kundeservice
fi Asennusohje
 *) Saatavissa huoltoavustusta
da Monteringsvejledning
 *) Kan købes hos serviceafdelingen
pl Instrukcja montażu
 *) Do uzyskania w punkcie serwisowym
hu Szerelési utasítás
 *) A vevőszolgálaton keresztül kapható:
lv Uputa za montažu
 *) može dobiti kod službe održavanja

mk Упатство за монтажа
 *) се добива преку службата за купувачи
sl Navodilo za montažo
 *) Lahko nabavite v servisni službi
sr Uputstvo za montažu
 *) Može se nabaviti preko servisne službe
et Monteerimisjuhend
 *) küsige klientiteeninduselt
lt Montavimo instrukcija
 *) ga galima gauti klientų aptarnavimo servise
lv Montāžas pamācība
 *) Var saņemt servisa dienestā
sk Návod na montáž
 *) Dostanete v službe zákazníkom
ku Udhëzues për montim
 *) Sigurohet nëpërmjet servisit
bs Uputa za montažu
 *) Može se dobiti preko servisne službe

fa راهنمای مونتاژ
 *) از مرکز خدمات پس از فروش تهیه فرمائید
ar تعليمات التركيب
 *) يمكن شتيها من مراكز خدمة العملاء
ko 설치 설명서
 *) 고객센터 센터에서 구입 가능
zh 安装说明书
 *) 可向售后服务站索取。
uk Інструкція з монтажу
 *) Можна отримати через сервісний сервіс
ru Инструкция de montaj
 *) obținabilă la serviciul pentru clienți
id Instruksi Pemasangan
 *) bisa didapatkan melalui Customer Service
kk Іске косу туралы нұсқаулар:
 *) Сервис қызметі арқылы орталыққа алуына жатады
bg Ръководство за монтаж
 *) претърсва се от служба за обслужване на клиенти

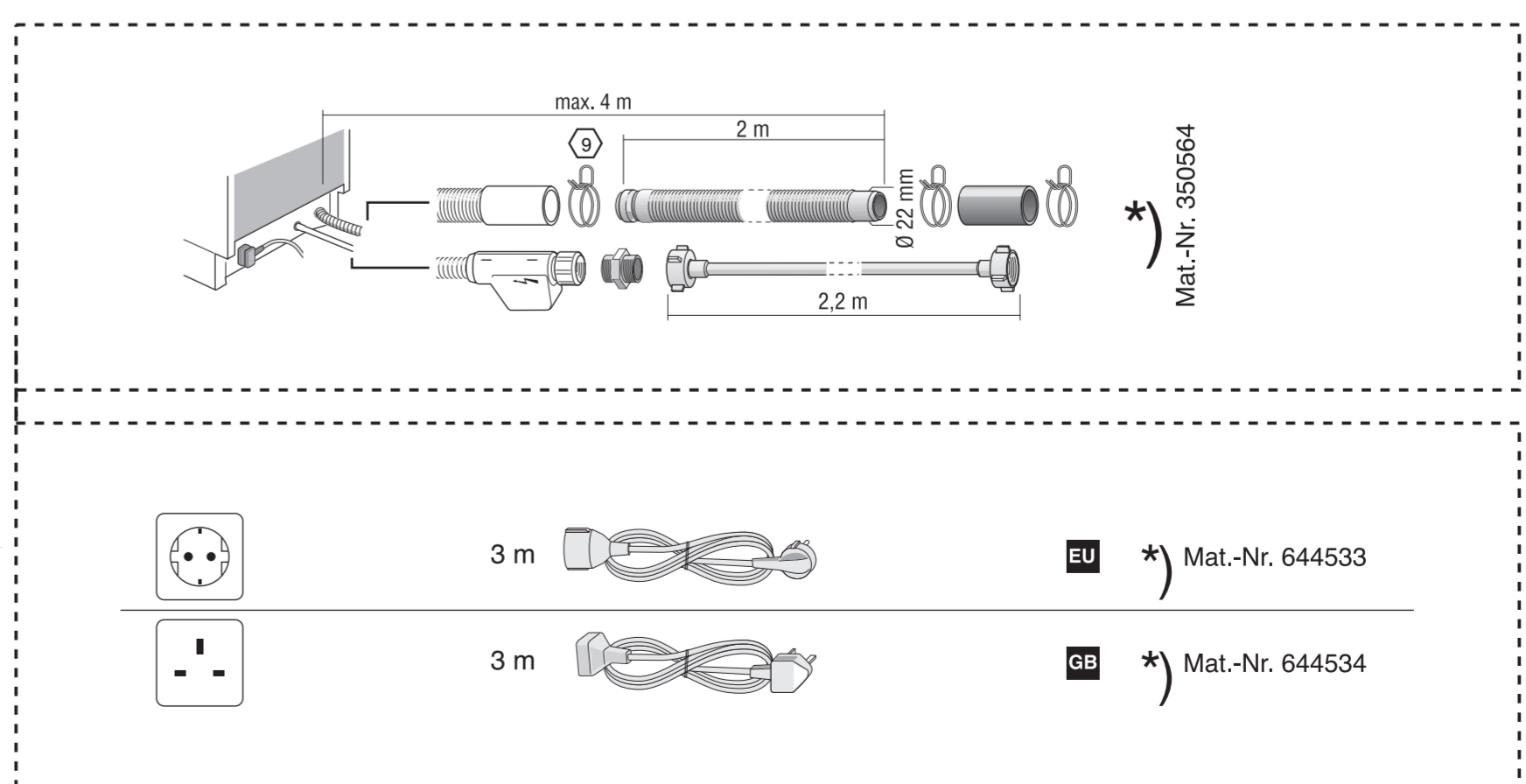
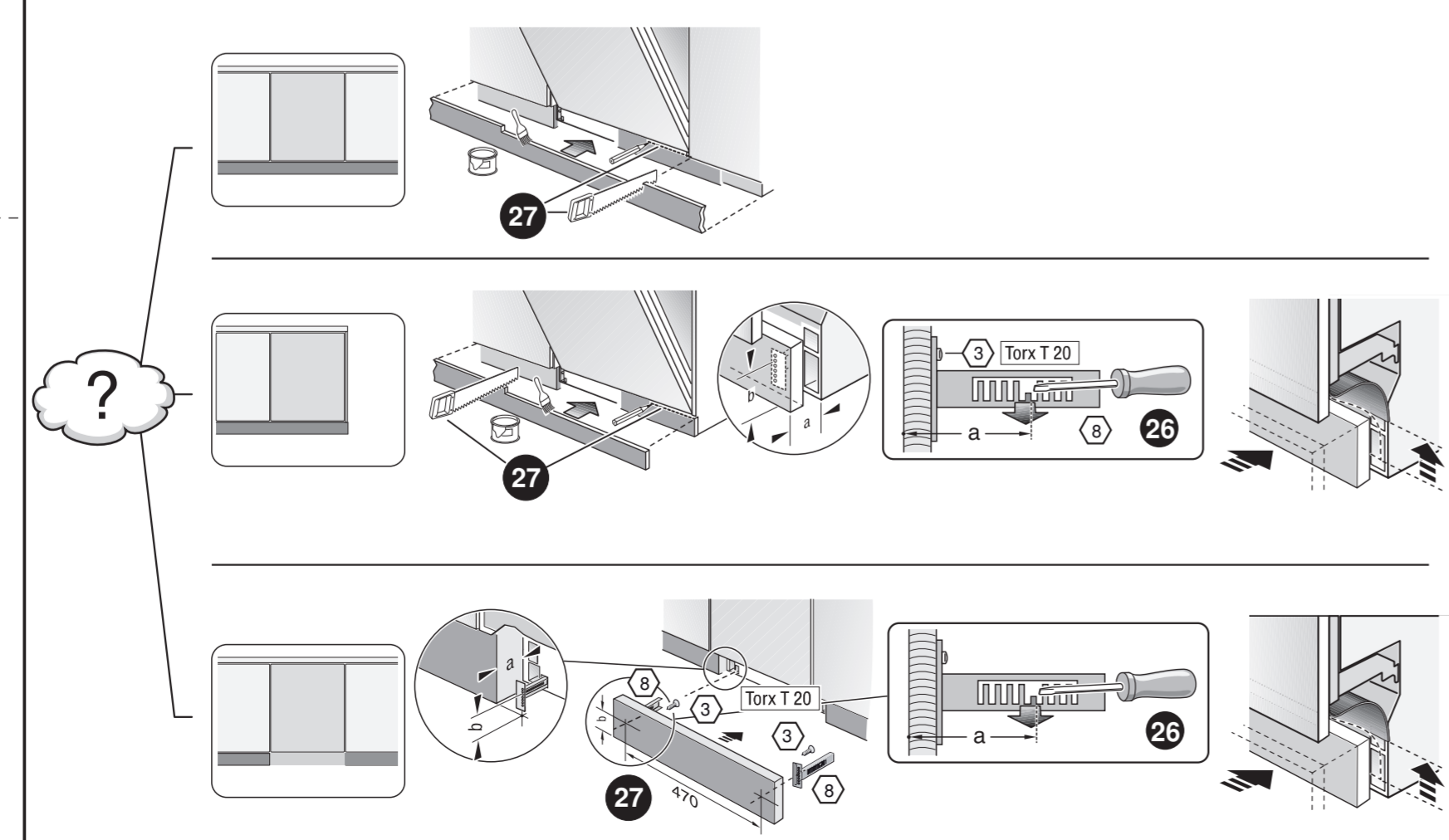
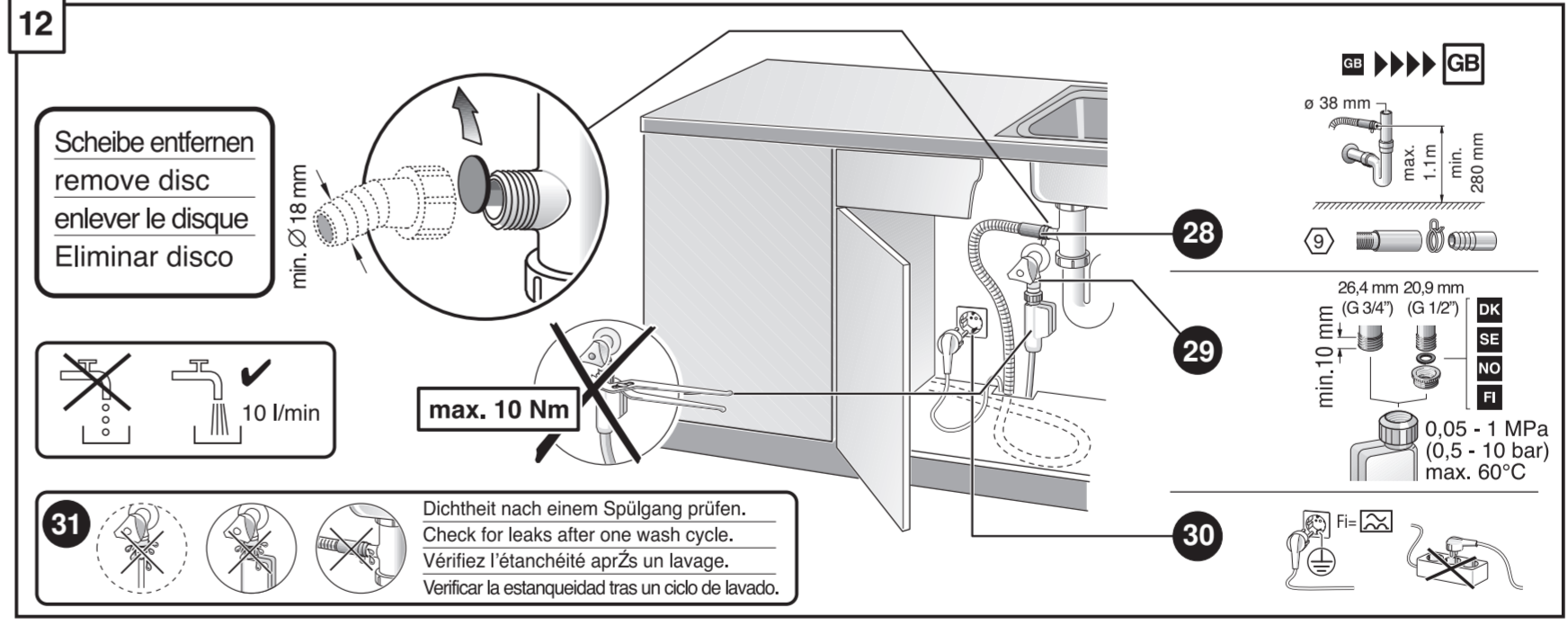
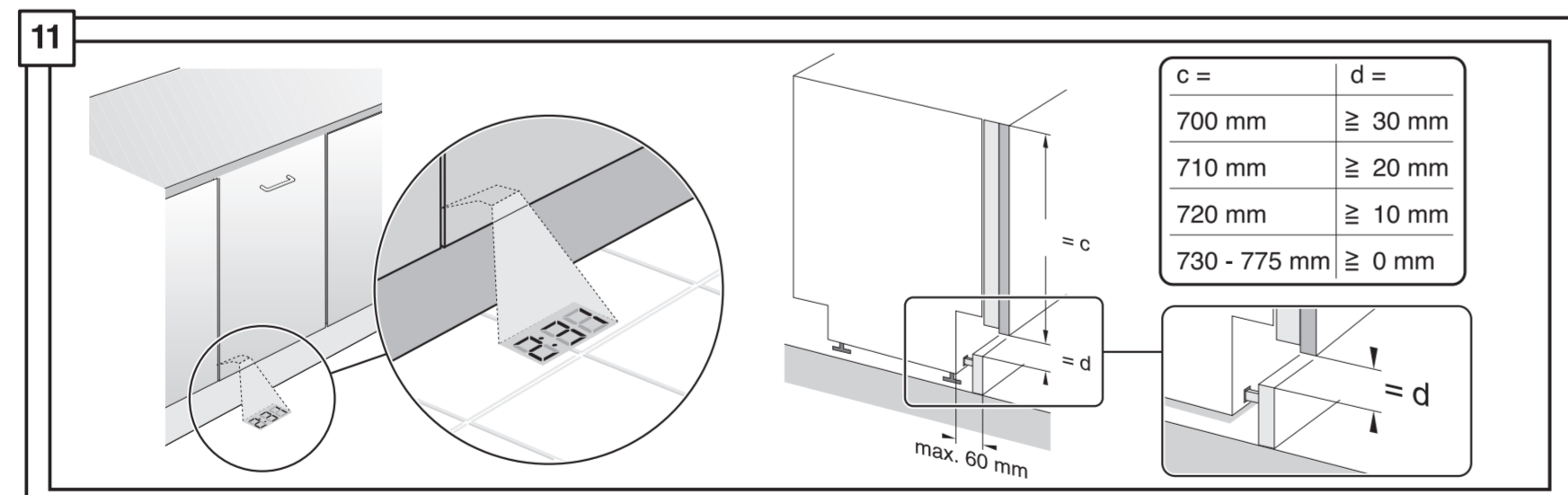
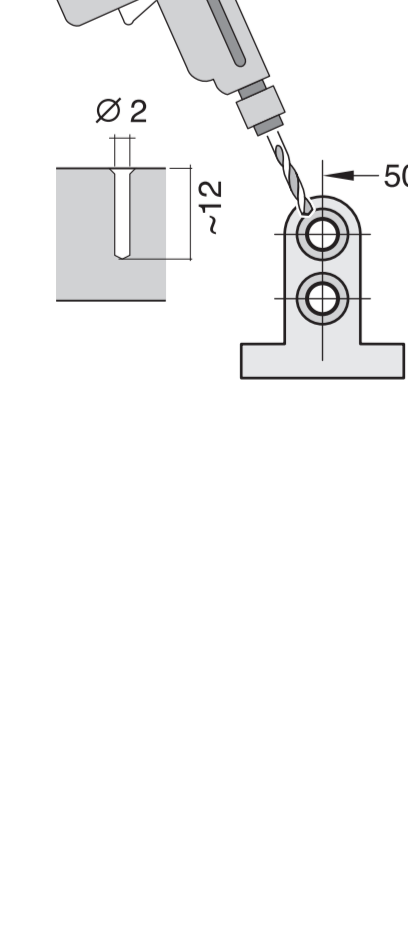
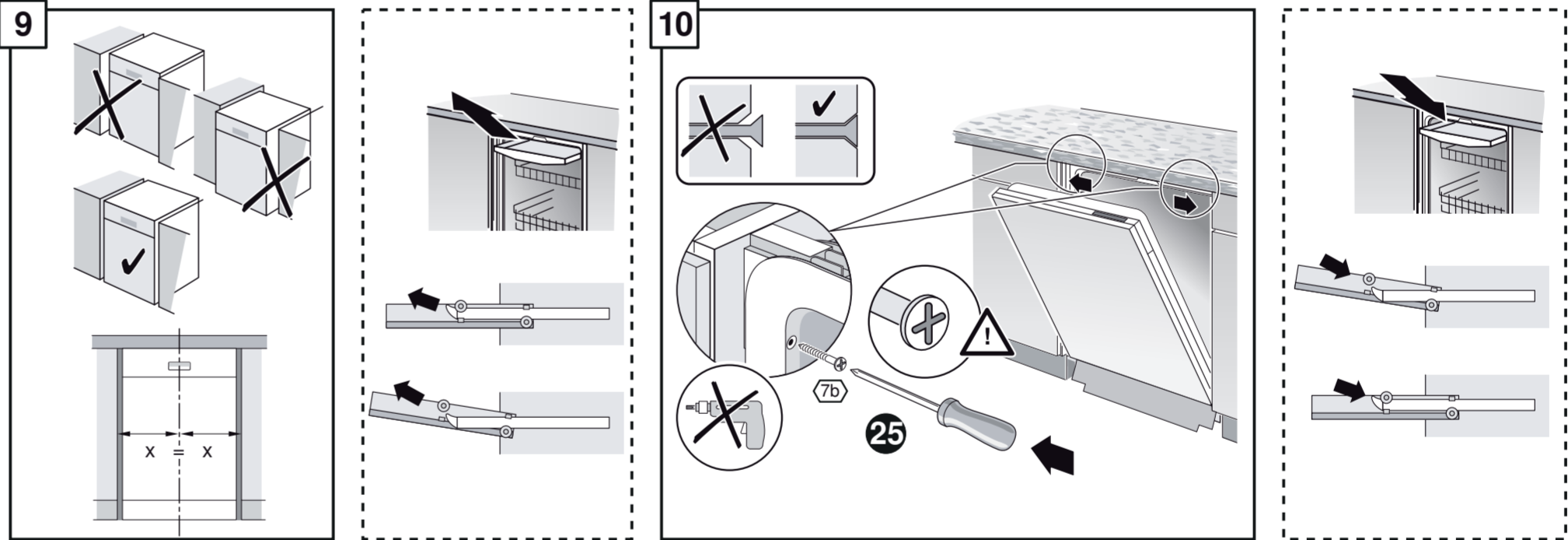
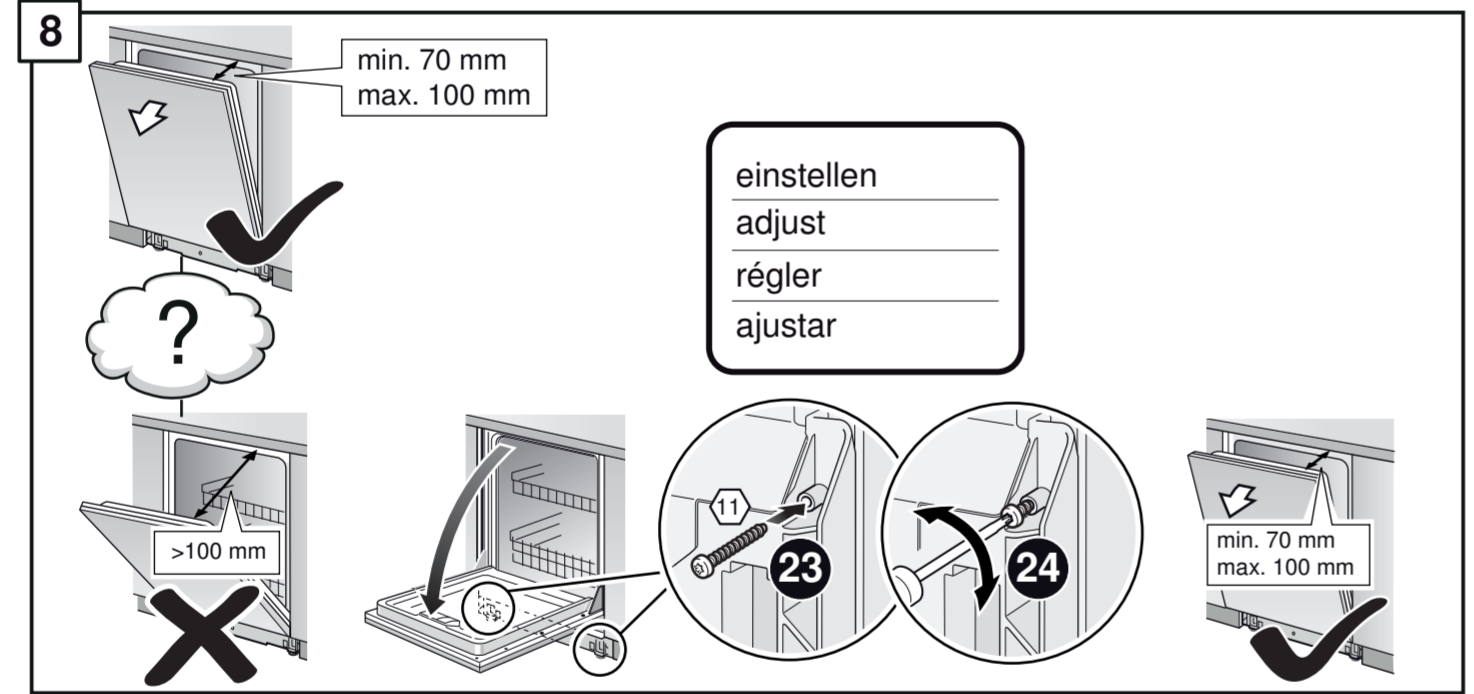
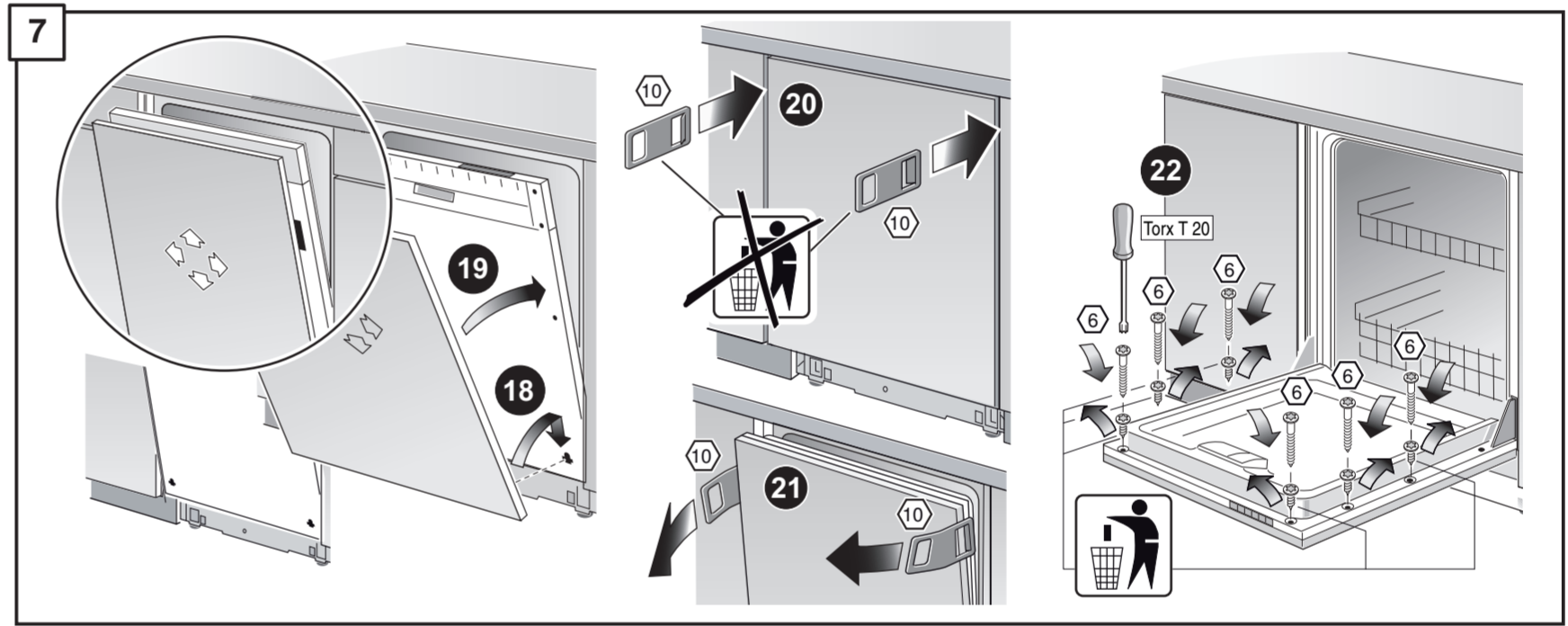
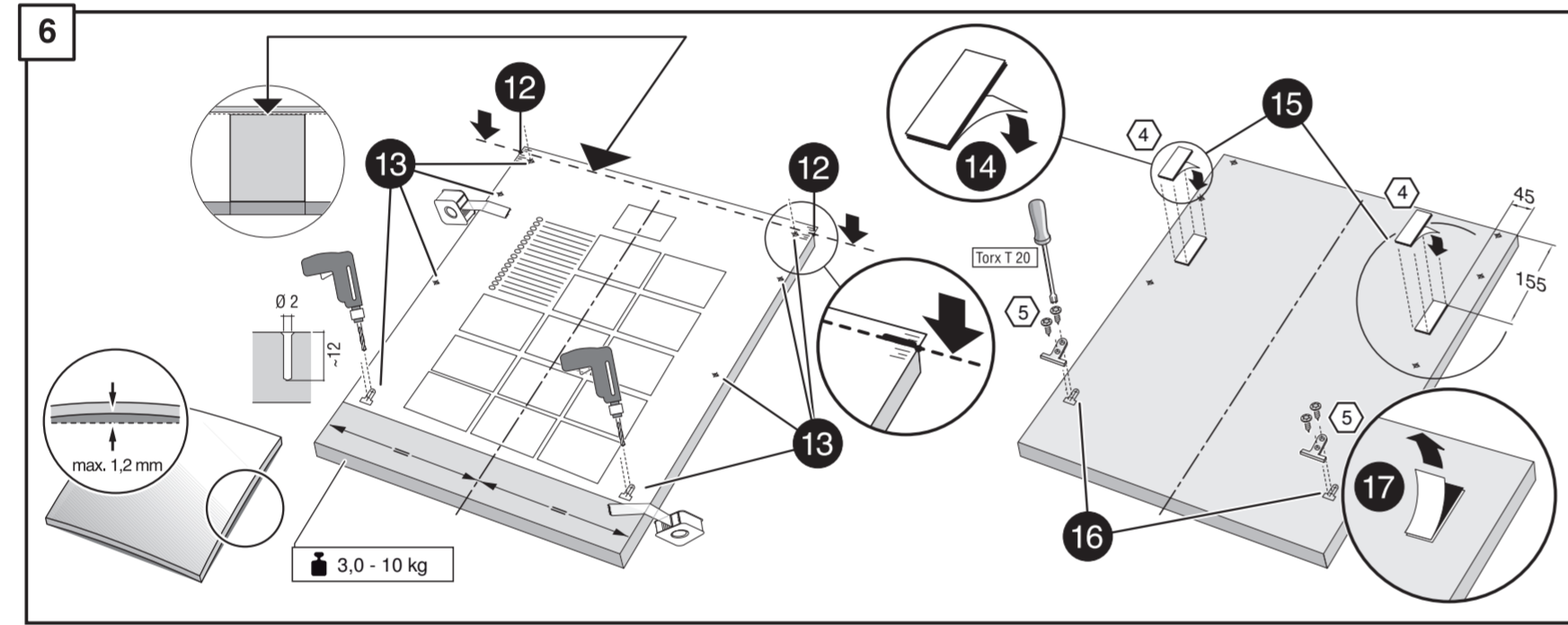
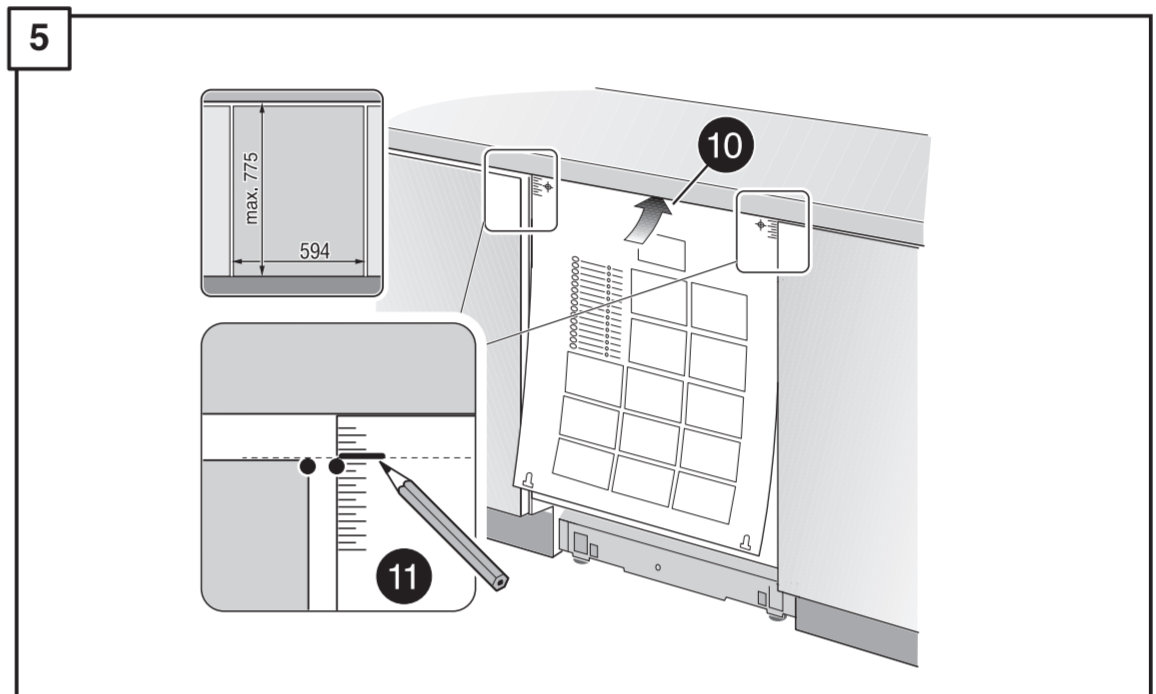
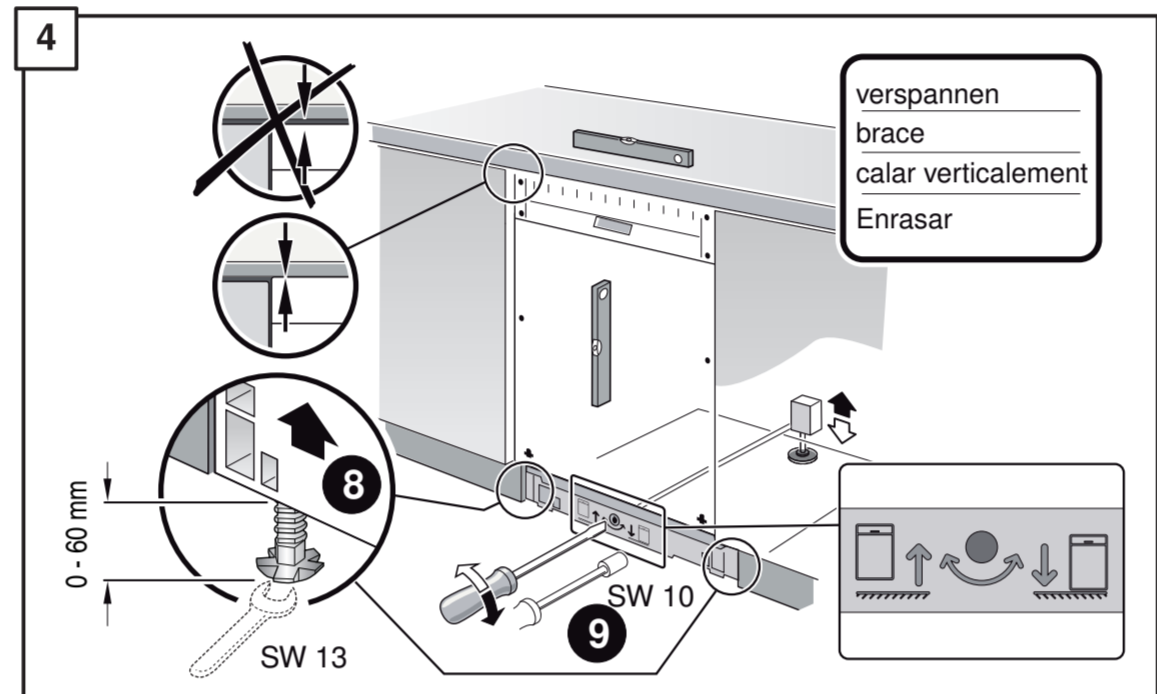
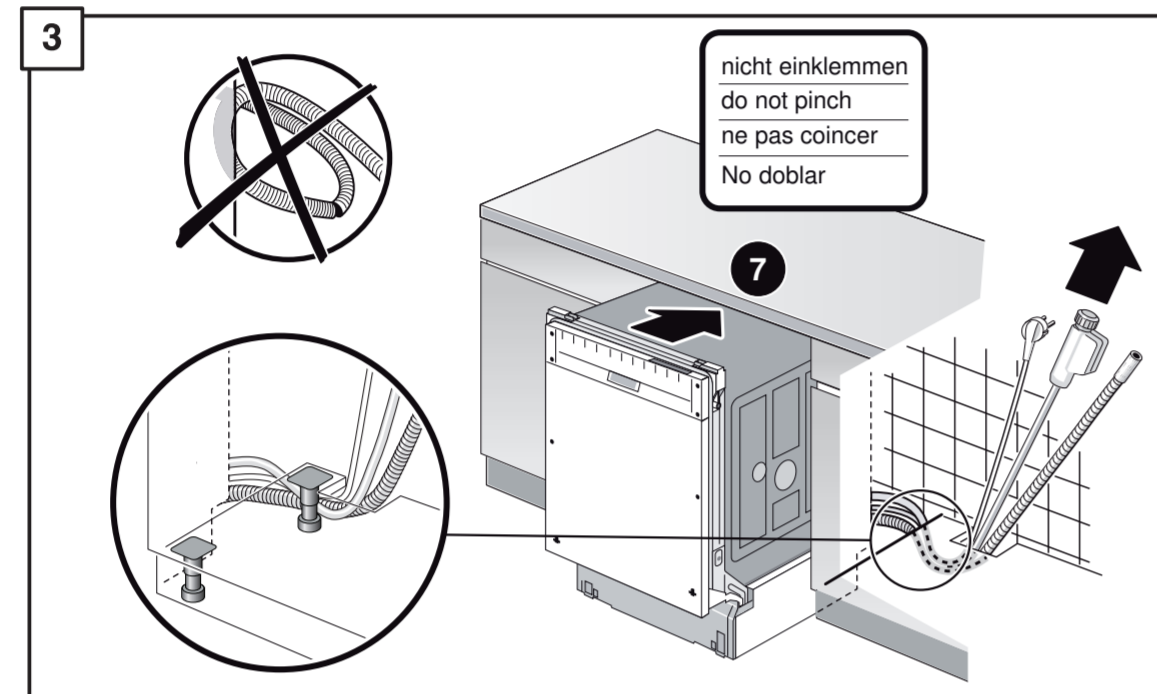
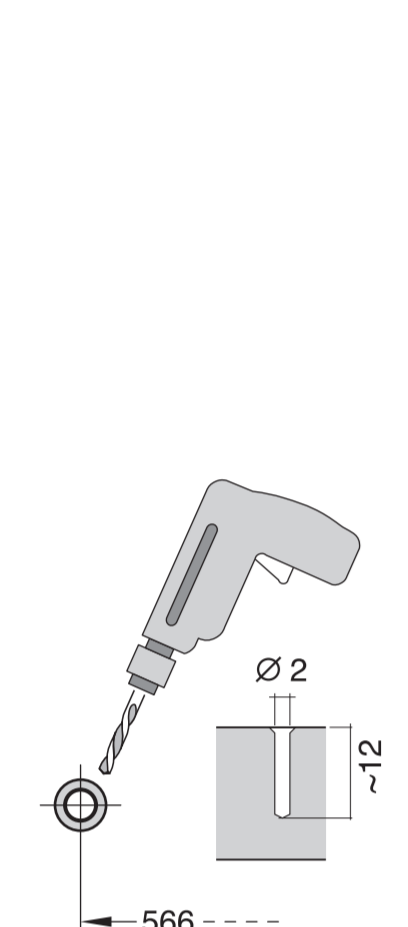
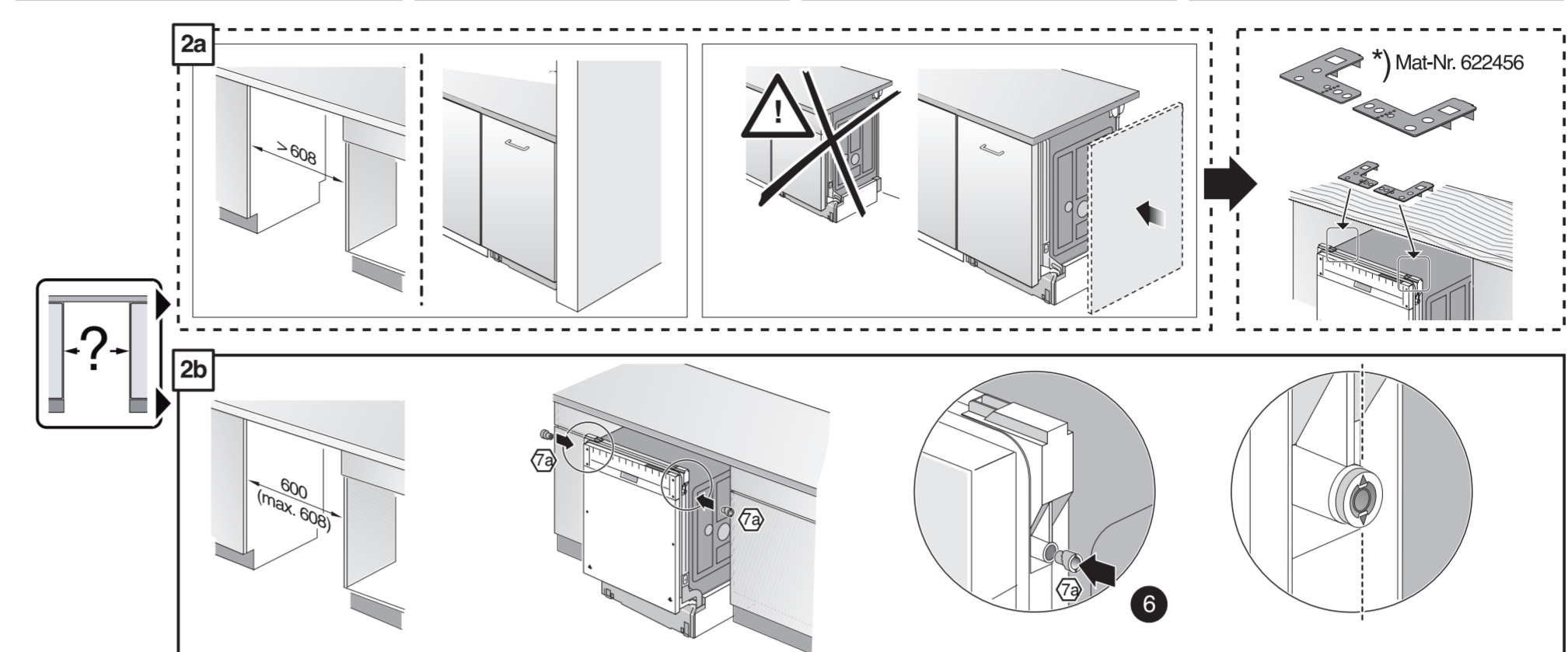
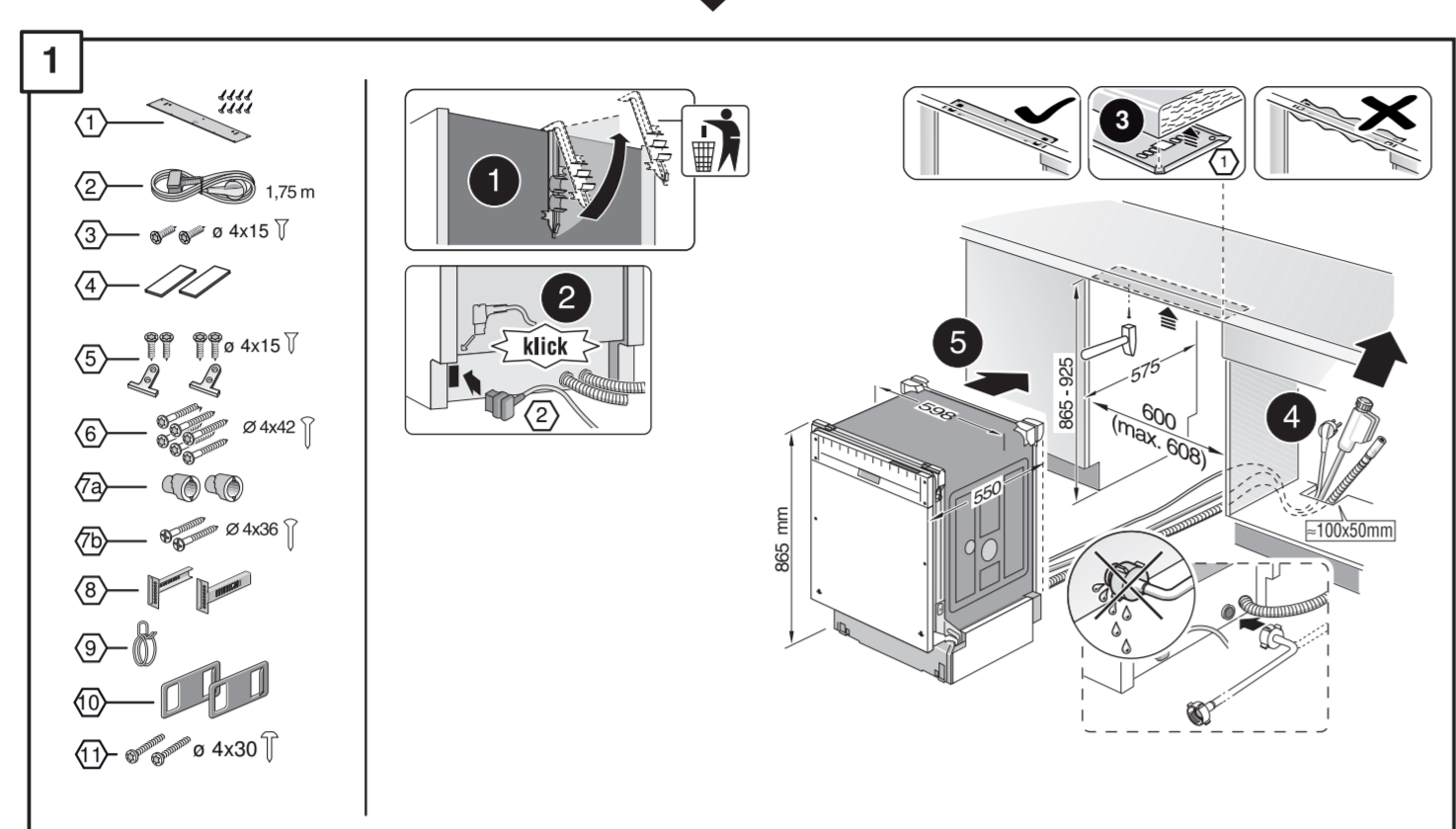
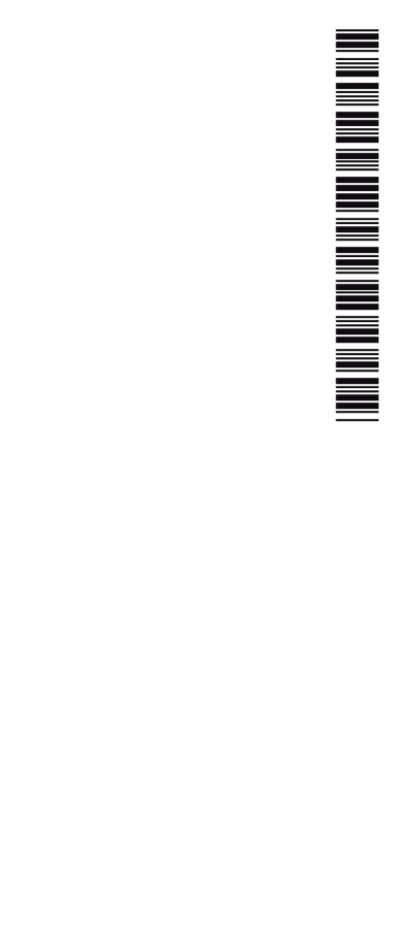

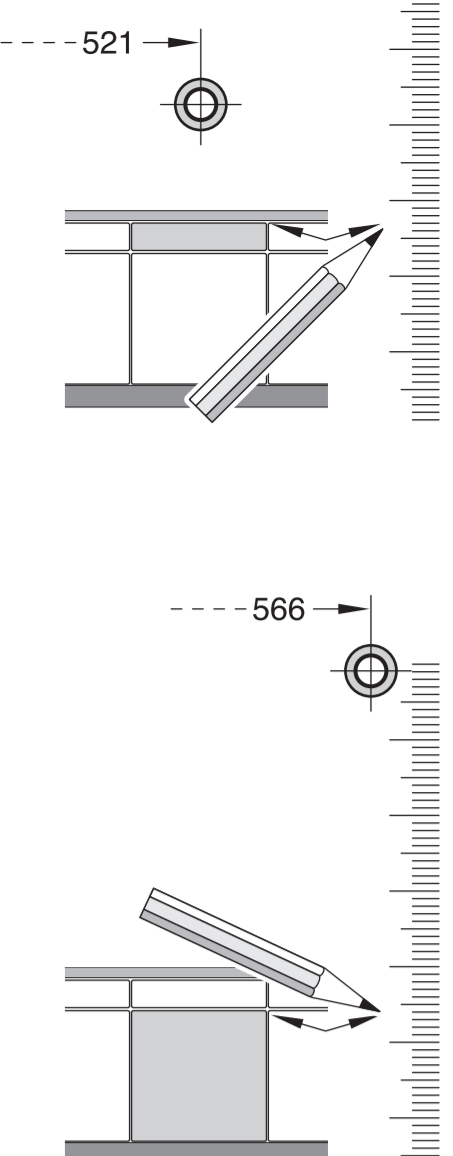
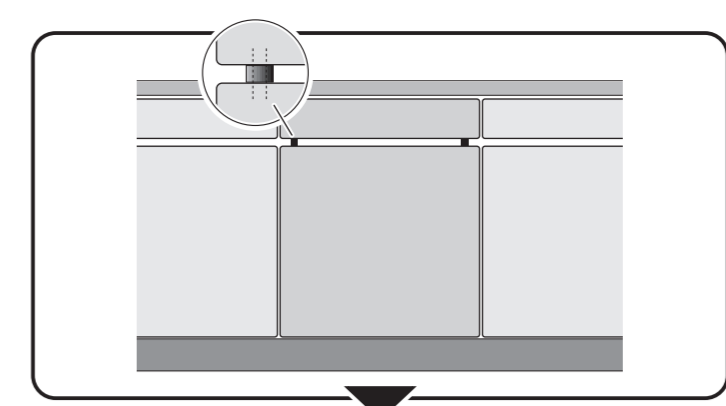
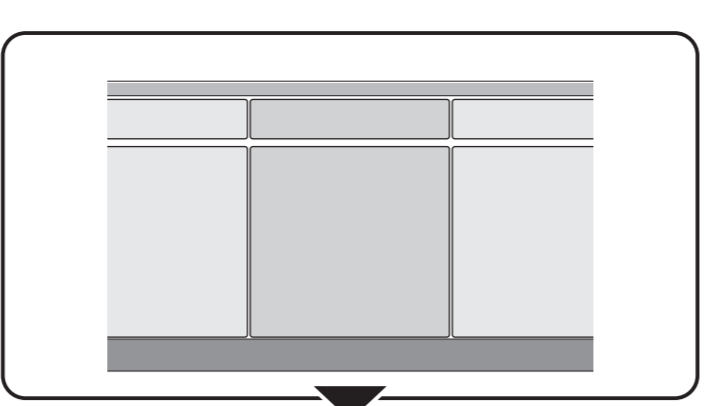
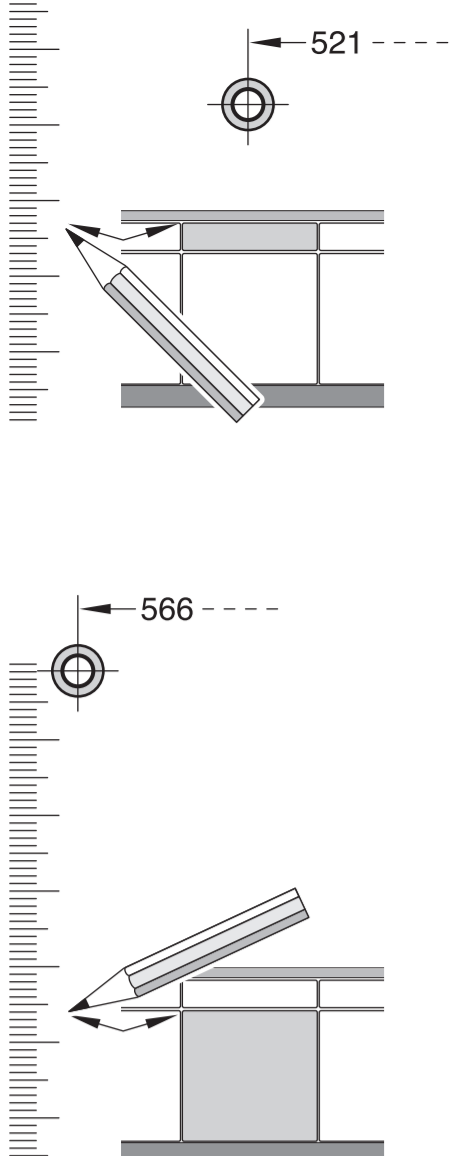

1

- 1 Screws 1.25m
- 2 Screws \varnothing 4x15
- 3 Screws \varnothing 4x15
- 4 Screws \varnothing 4x2
- 5 Screws \varnothing 4x30
- 6 Screws \varnothing 4x2
- 7 Screws \varnothing 4x30
- 8 Screws \varnothing 4x30
- 9 Screws \varnothing 4x30
- 10 Screws \varnothing 4x30
- 11 Screws \varnothing 4x30

2a

2b

Mat-Nr. 622456

3

nicht einklemmen
do not pinch
ne pas coincer
No doblar

4

verspannen
brace
calar verticalment
Enrasar

\varnothing 2
SW 10
SW 13

5

6

\varnothing 2

7

3.0 - 10 kg

1

4

5A

6A

7A

8 ▶▶▶▶ **12**

8

min. 70 mm
max. 100 mm

einstellen
adjust
régler
ajustar

>100 mm

min. 70 mm
max. 100 mm

9

X = X

10

23

11

c = 700 mm
d = 30 mm

c = 710 mm
d = 20 mm

c = 720 mm
d = 10 mm

c = 730 - 775 mm
d = 0 mm

max. 60 mm

12

Scheibe entfernen
remove disc
enlever le disque
Eliminar disco

min. \varnothing 18 mm

max. 10 Nm

31 \varnothing 38 mm

32 26.4 mm 20.9 mm (0.84) (0.82)

33 min. 10 mm

34 0,05 - 1 MPa (0.5 - 10 bar) max. 60°C

30

30

max. 4 m

2 m

\varnothing 22 mm

2.2 m

Mat-Nr. 350664

3m **EU** *) Mat-Nr. 644533

3m **GB** *) Mat-Nr. 644534

