

640 Integr. Niro-Leisten - 81,5 cm - m. GS 9001 110 731 (9505)

**de** Montageanleitung  
 \*) Über Kundendienst erhältlich  
**en** Installation instructions  
 \*) Available from customer service  
**fr** Notice de montage  
 \*) Disponible par le biais du service après-vente  
**nl** Montagevoorschrift  
 \*) Tegen meerprijs bij de ServiceDienst verkrijgbaar  
**it** Istruzioni per il montaggio  
 \*) Disponibile presso il servizio assistenza clienti  
**el** Οδηγός τοποθέτησης  
 \*) Διαθέσιμα από την υπηρεσία τεχνικής εξυπηρέτησης πελατών

**es** Instrucciones de montaje  
 \*) Se puede adquirir a través del Servicio de Asistencia Técnica Oficial de la marca  
**pt** Instruções de montagem  
 \*) Pode ser adquirido nos nossos Serviços Técnicos  
**sv** Monteringsanvisning  
 \*) Kan fås via Service  
**no** Monteringsanvisning  
 \*) fåes hos kundeservice  
**fi** Asennusohje  
 \*) Saatavissa huoltopalvelusta  
**da** Monteringsvejledning  
 \*) Kan købes hos serviceafdelingen

**tr** Montaj kılavuzu  
 \*) Yetkili servis üzerinden alınabilir  
**ru** Инструкция по монтажу  
 \*) Можно получить в сервисном центре  
**cs** Montážní návod  
 \*) K dispozici přes servisní službu  
**pl** Instrukcja montażu  
 \*) Do uzyskania w punkcie serwisowym  
**hu** Szerelési utasítás  
 \*) A vevőszolgálaton keresztül kapható:  
**hr** Uputa za montažu  
 \*) može dobiti kod službe održavanja

**mk** Упатство за монтажа  
 \*) се добива преку службата за купувачи  
**sl** Navodilo za montažo  
 \*) Lahko nabavite v servisni službi  
**sk** Uputstvo za montažu  
 \*) Može se nabaviti preko servisne službe  
**et** Monteerimisjuhend  
 \*) Kõige klientiteeninduselt  
**lt** Montavimo instrukcija  
 \*) Ja galima gauti klientų aptarnavimo servise  
**lv** Montāžas pamācība  
 \*) Var saņemt servisa dienestā

**sk** Návod na montáž  
 \*) Dostanete v službe zákazníkom  
**scj** Udružues pŕ montim  
 \*) Sigurohet nëpërmjet servisit  
**bs** Uputa za montažu  
 \*) Može se dobiti preko servisne službe  
**fa** راهنمای مونتاژ  
 \*) از فروش خدمات پس از فروش تهیه فرمایید  
**ar** تعليمات التركيب  
 \*) يمكن طلبها من مراكز خدمة العملاء  
**ko** 설치 설명서  
 \*) 고객센터 서비스 센터에서 구입 가능

**zh** 安装说明书  
 \*) 可向售后服务站索取。  
**uk** Інструкція з монтажу  
 \*) Можна отримати через сервісну службу  
**ro** Instrucțiune de montaj  
 \*) disponibilă la serviciul pentru clienți  
**id** Intruksi Pemasangan  
 \*) bisa didapatkan melalui Customer Service  
**ky** сже косу тураны нускалулар!  
 \*) Сервис кызмет керсету орталыгында алуна жатады

**1** Preparation of the cabinet cutout. Dimensions: 815 mm height, 600 mm (max. 608) width. Step 1 shows the cabinet being inserted into the cutout.

**2** Attaching the top panel. Step 2 shows the top panel being secured with screws (8) and washers (9a).

**3** Leveling the cabinet. Step 3 shows the cabinet being leveled using leveling feet (9b) and a spirit level. Dimensions: 575 mm, 600 mm (max. 608), 100-50 mm.

**4a** Attaching the top panel (continued). Step 4a shows the top panel being secured with screws (8) and washers (9a).

**4b** Attaching the top panel (continued). Step 4b shows the top panel being secured with screws (8) and washers (9a).

**5** Drilling the cabinet. Step 5 shows the cabinet being drilled with a 2 mm drill bit (Ø 2) at a depth of approximately 12 mm (~12). Dimensions: 566 mm.

**6** Tensioning the braces. Step 6 shows the braces being tensioned vertically using a screwdriver (SW 10) and a wrench (SW 13). Dimensions: 0-60 mm.

**7** Attaching the door. Step 7 shows the door being attached to the cabinet using screws (10) and washers (11). Dimensions: max. 725 mm, max. 167 mm, 584 mm.

**8** Attaching the door (continued). Step 8 shows the door being attached to the cabinet using screws (10) and washers (11). Dimensions: max. 1.2 mm, 2.5-8.5 kg.

**9** Adjusting the door. Step 9 shows the door being adjusted using screws (12) and washers (13). Dimensions: 12-11 mm, 12-20 mm, 21-29 mm, 30-39 mm, 63-68 mm. Material numbers: Mat.-Nr. 674259, Mat.-Nr. 674253.

**10** Adjusting the door (continued). Step 10 shows the door being adjusted using screws (12) and washers (13). Dimensions: 19 mm, 20 mm, 21 mm, 22 mm, 23 mm.

**11** Adjusting the door (continued). Step 11 shows the door being adjusted using screws (12) and washers (13). Dimensions: min. 70 mm, max. 150 mm. Material number: Mat.-Nr. 674259.

**12** Adjusting the door (continued). Step 12 shows the door being adjusted using screws (12) and washers (13). Dimensions: X, X.

**13** Adjusting the door (continued). Step 13 shows the door being adjusted using screws (12) and washers (13). Dimensions: 26 mm.

**14** Adjusting the door (continued). Step 14 shows the door being adjusted using screws (12) and washers (13). Dimensions: 502 mm, ~12 mm, 28 mm, 27 mm, 28 mm, 470 mm.

**15** Adjusting the door (continued). Step 15 shows the door being adjusted using screws (12) and washers (13). Dimensions: 38 mm, min. 280 mm, max. 1.1 m, 29 mm, 25.4 mm, 20.9 mm, 30 mm, min. 10 mm, 10 l/min, max. 10 Nm, 31 mm, 0.05-1 MPa (0.5-10 bar), max. 60°C.

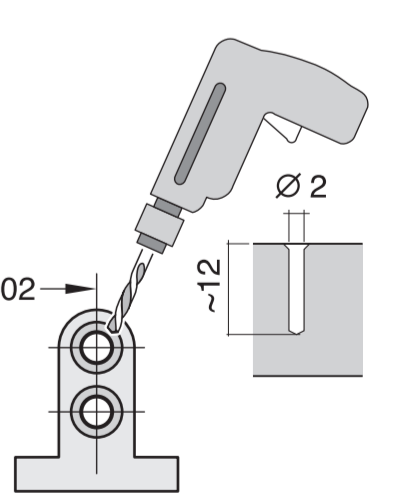
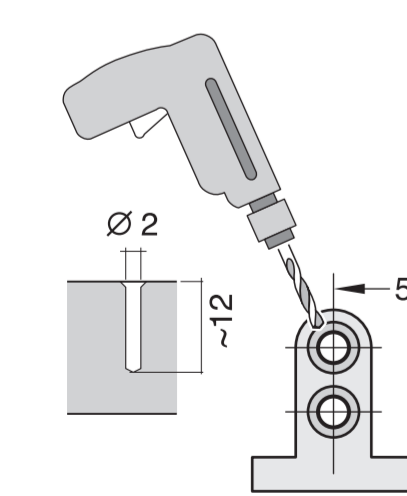
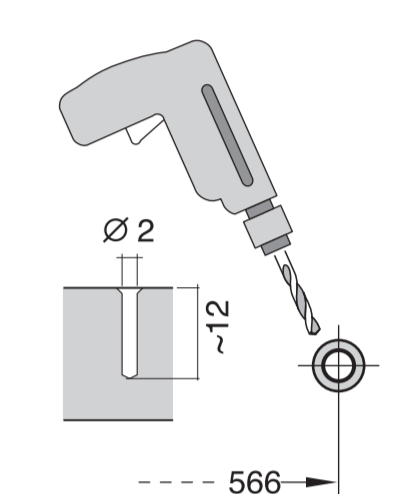
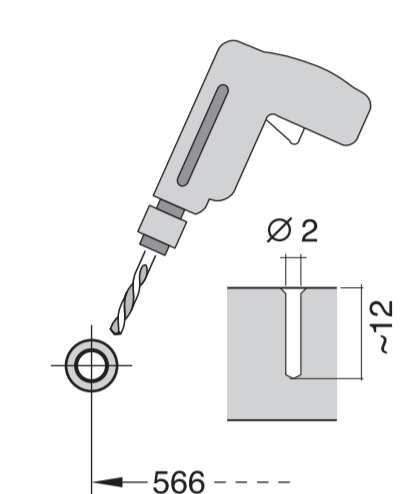

max. 4 m  
 2 m  
 2.2 m  
 Ø 22 mm  
 Mat.-Nr. 350564  
 3 m EU \*) Mat.-Nr. 644533  
 3 m GB \*) Mat.-Nr. 644534

max. 1.1 m  
 Mat.-Nr. 657927