

GV 640 Voll-I - 86,5 cm - m. GS 9001 107 616 (9509)

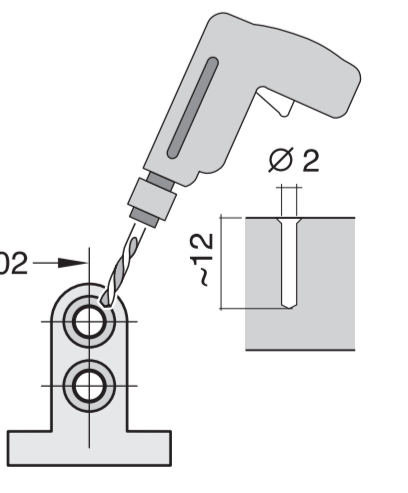
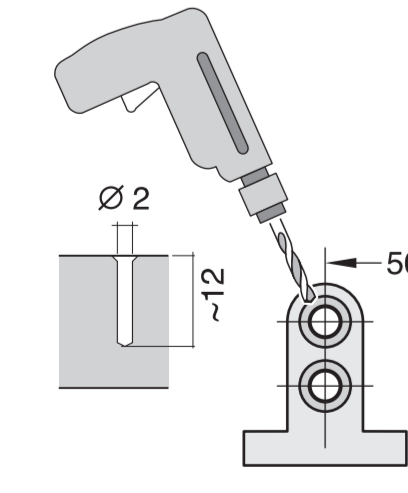
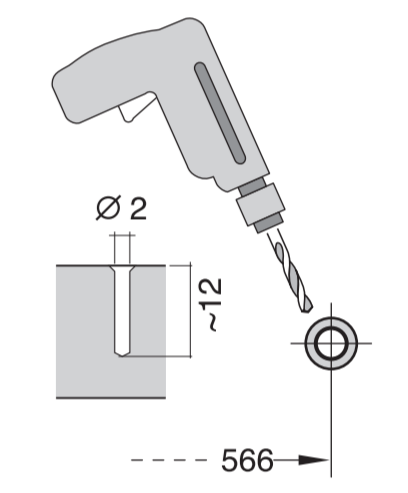
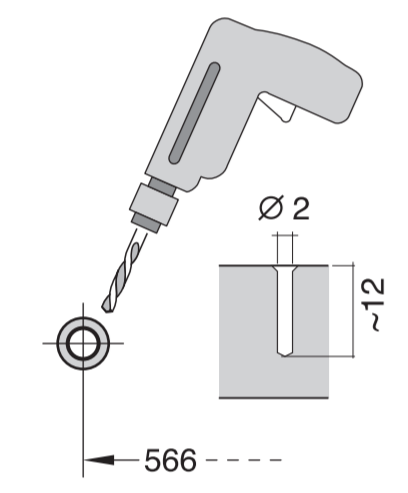
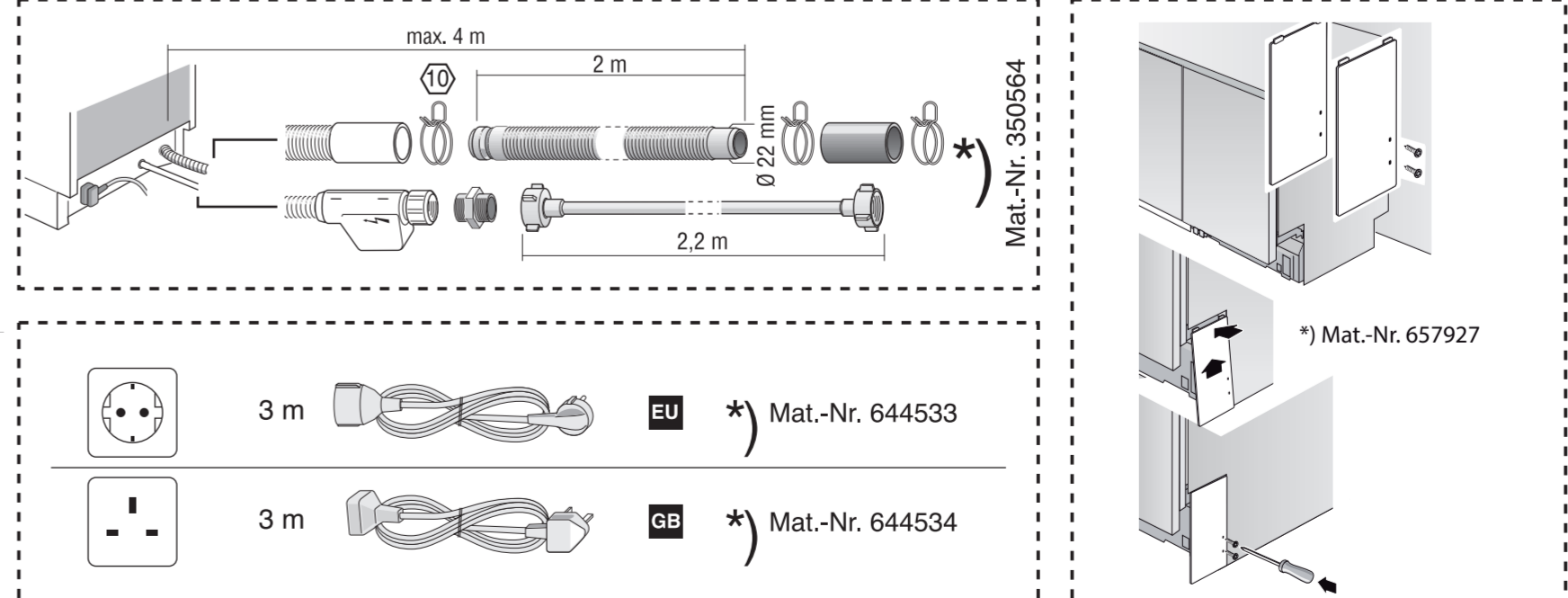
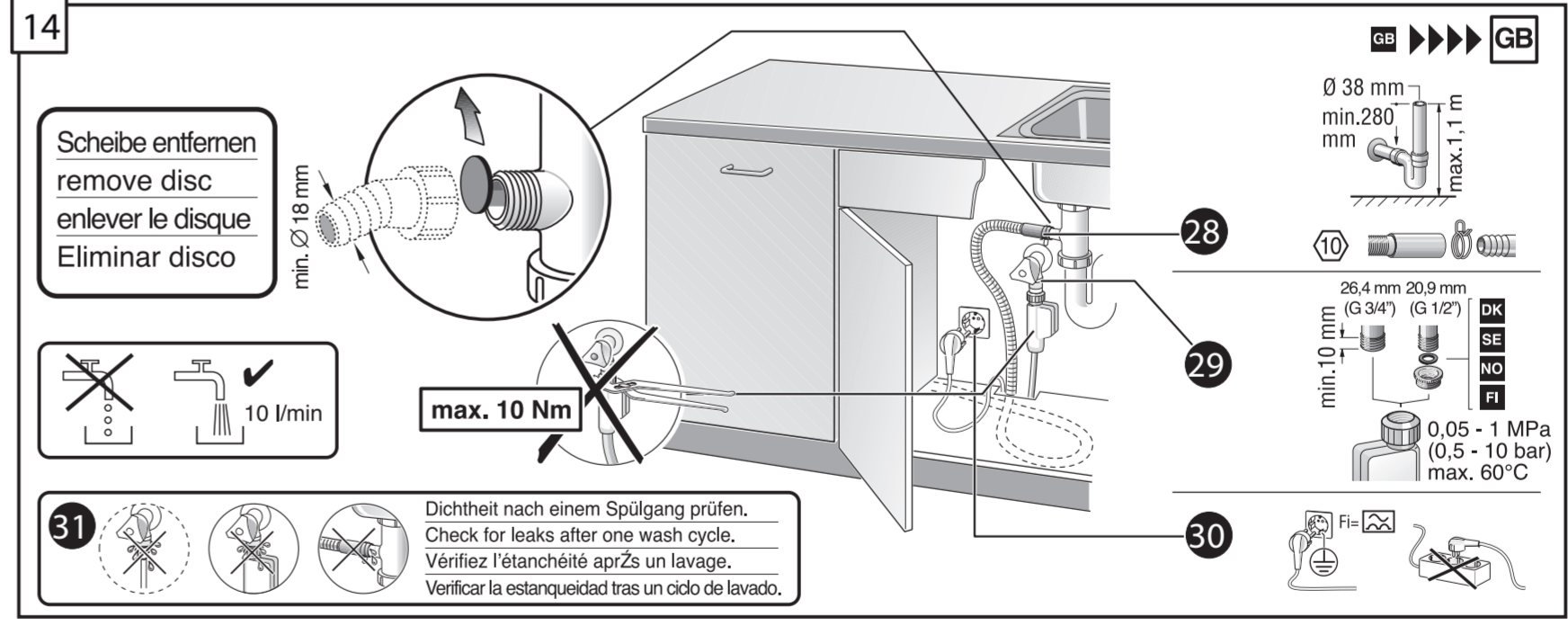
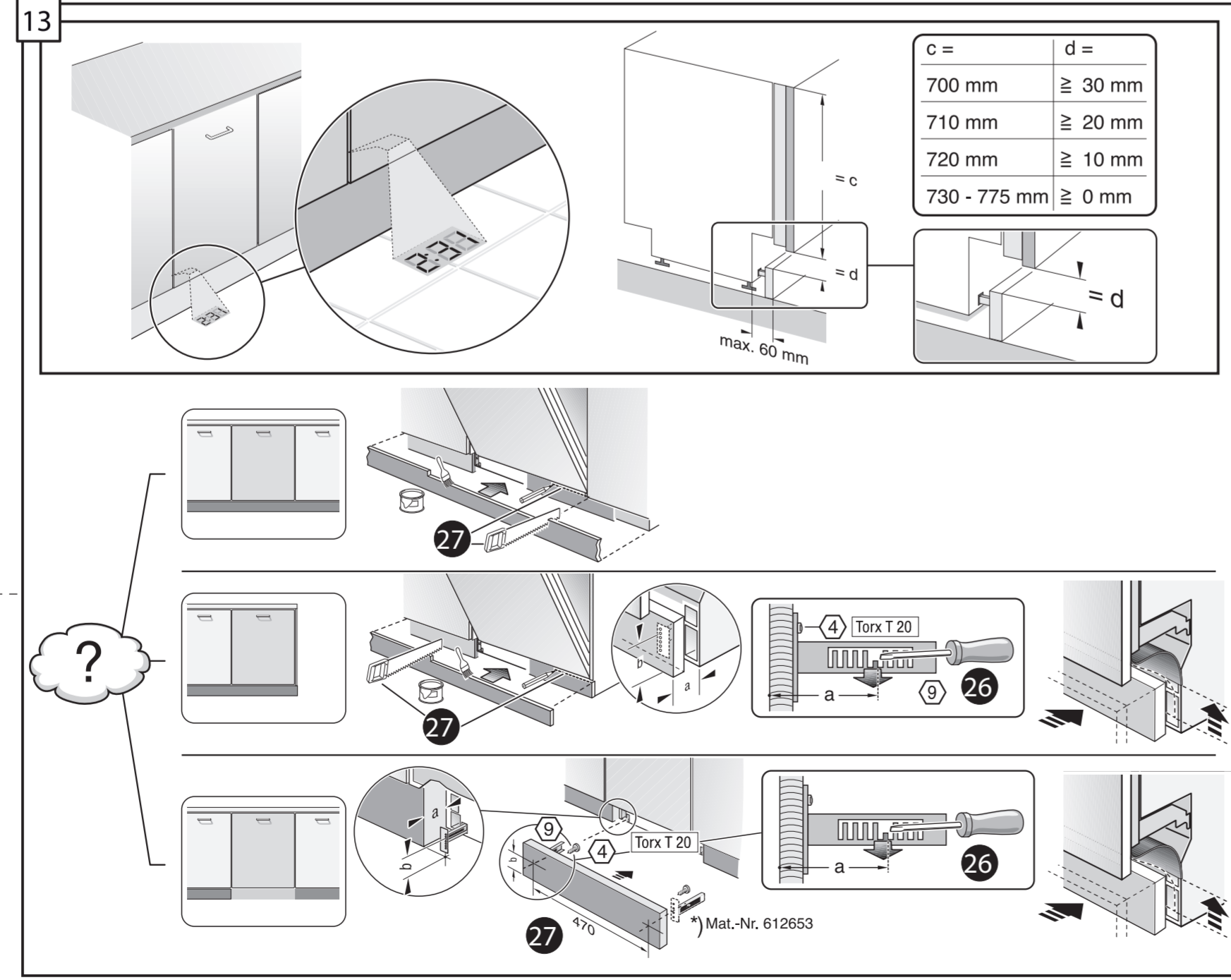
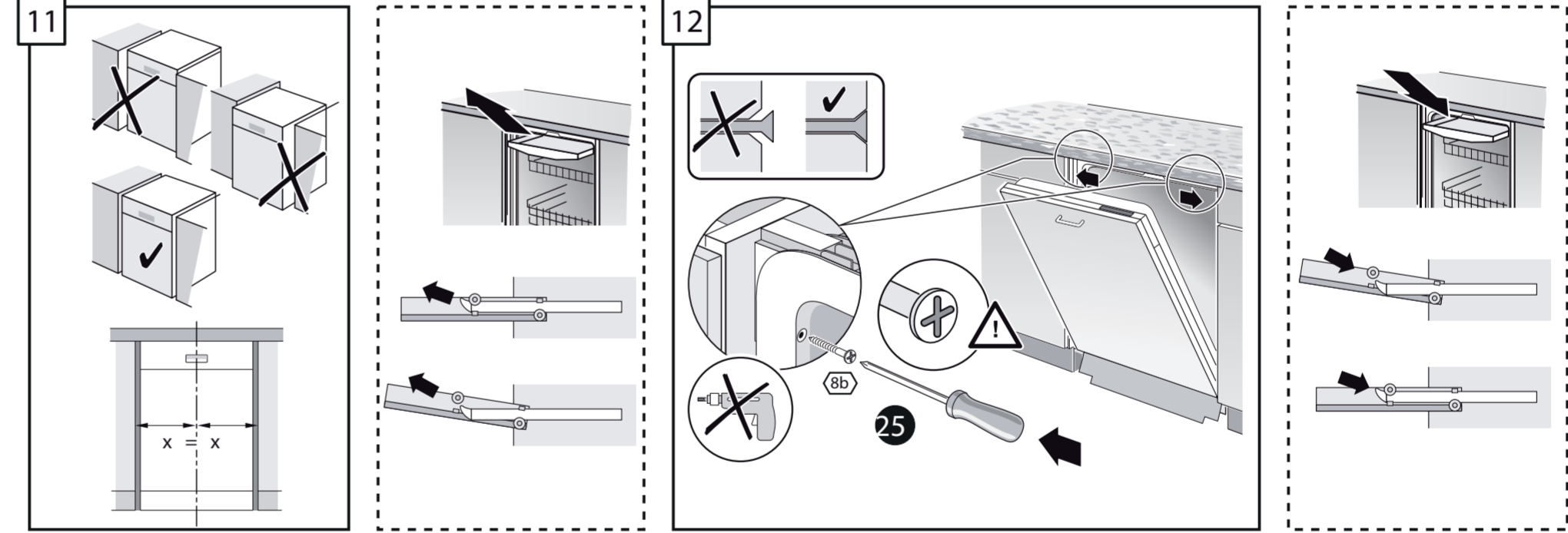
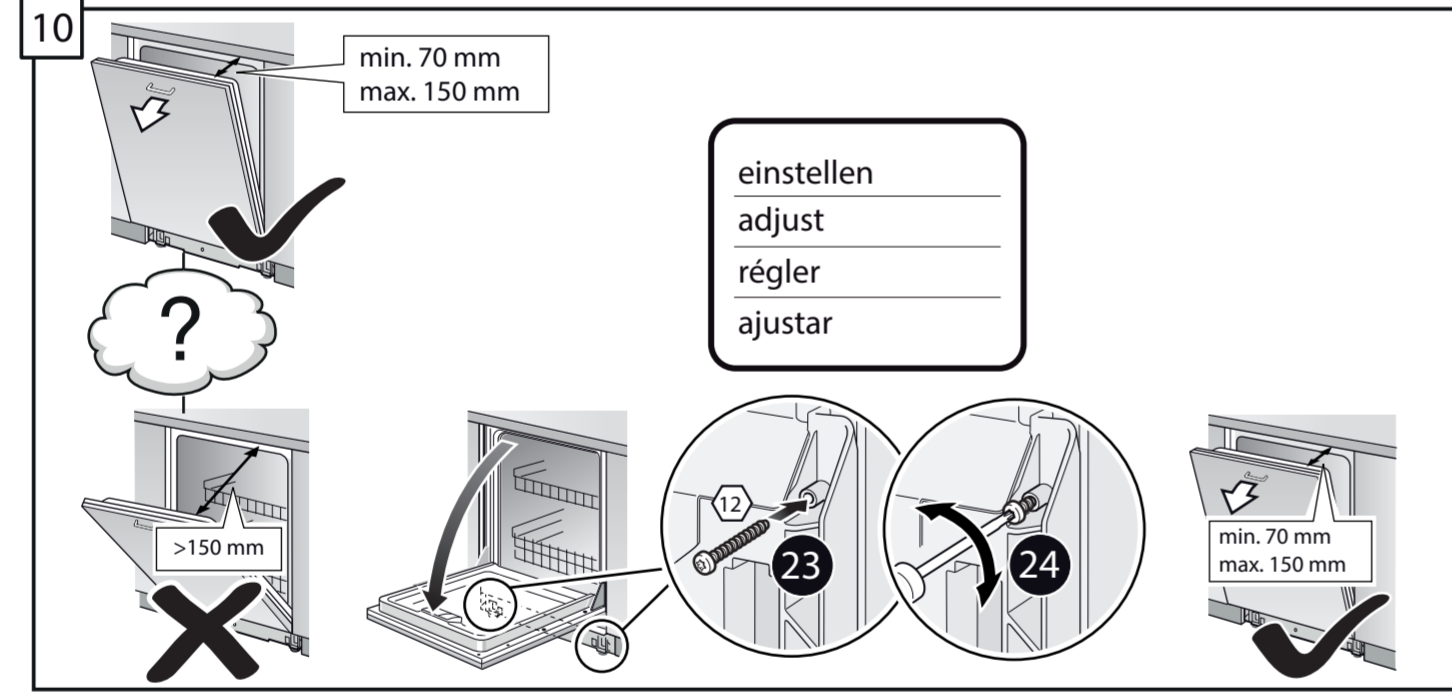
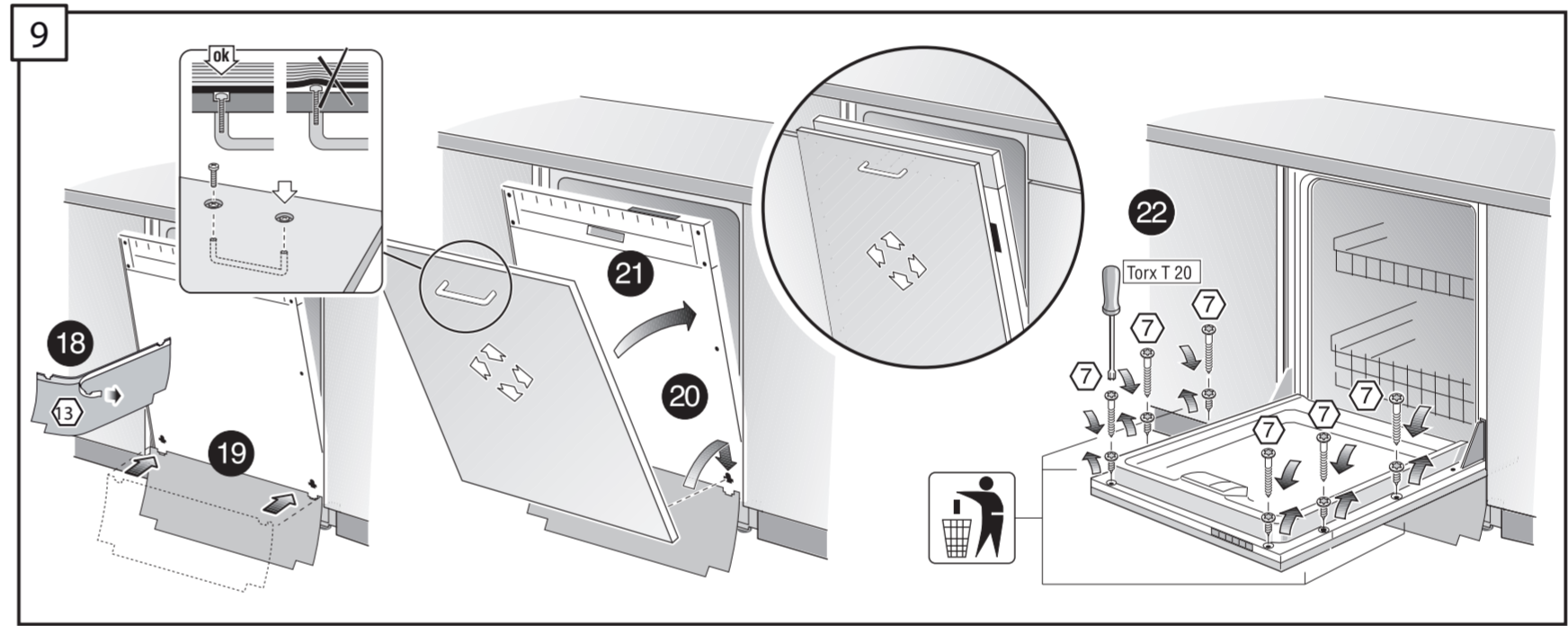
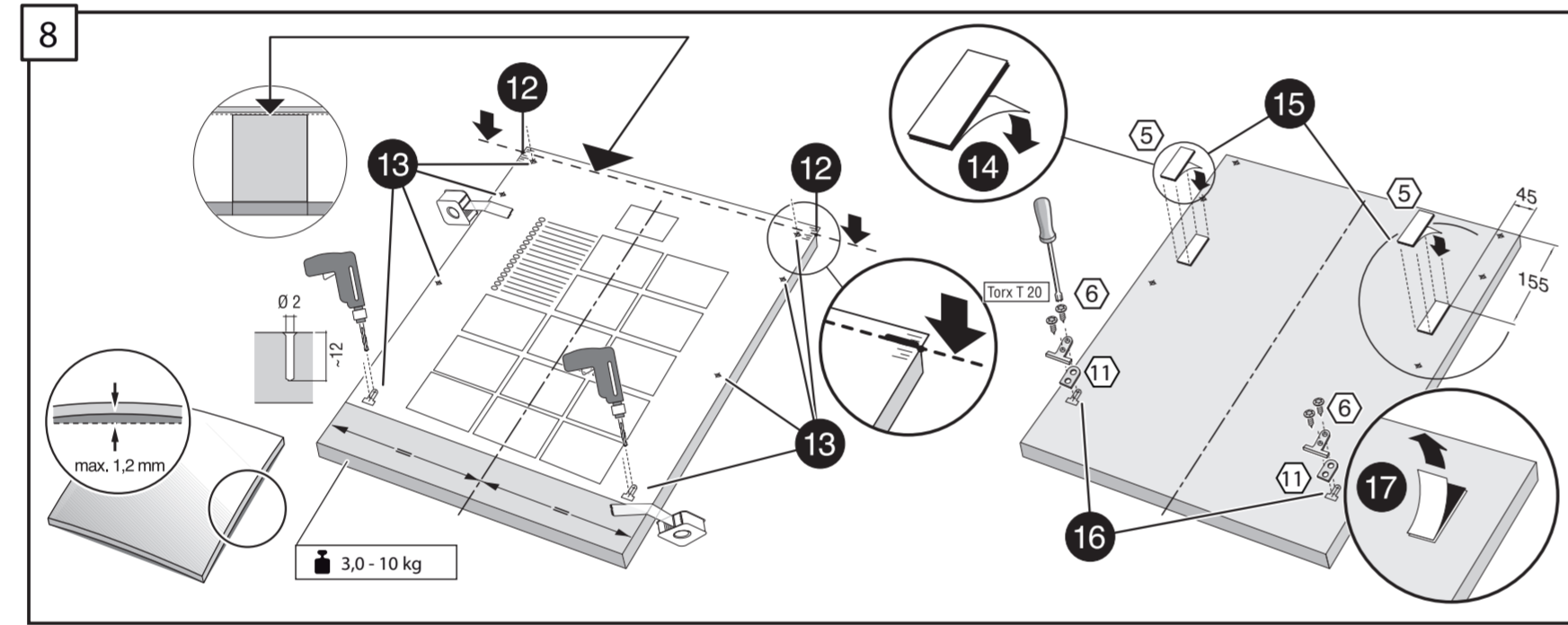
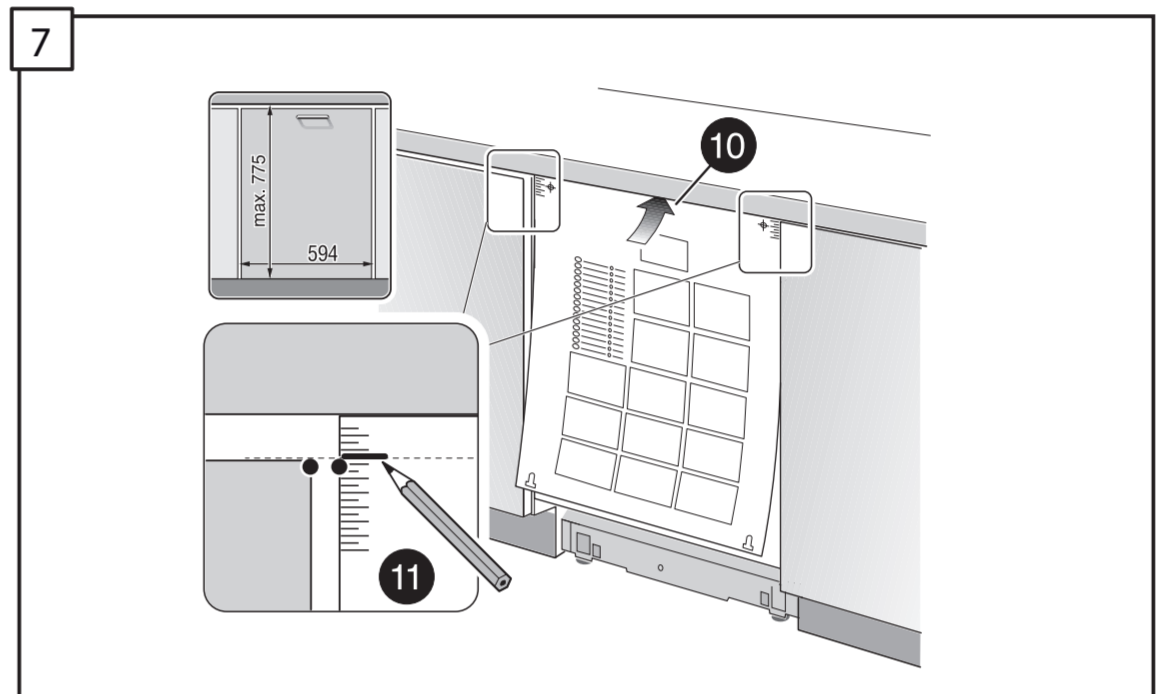
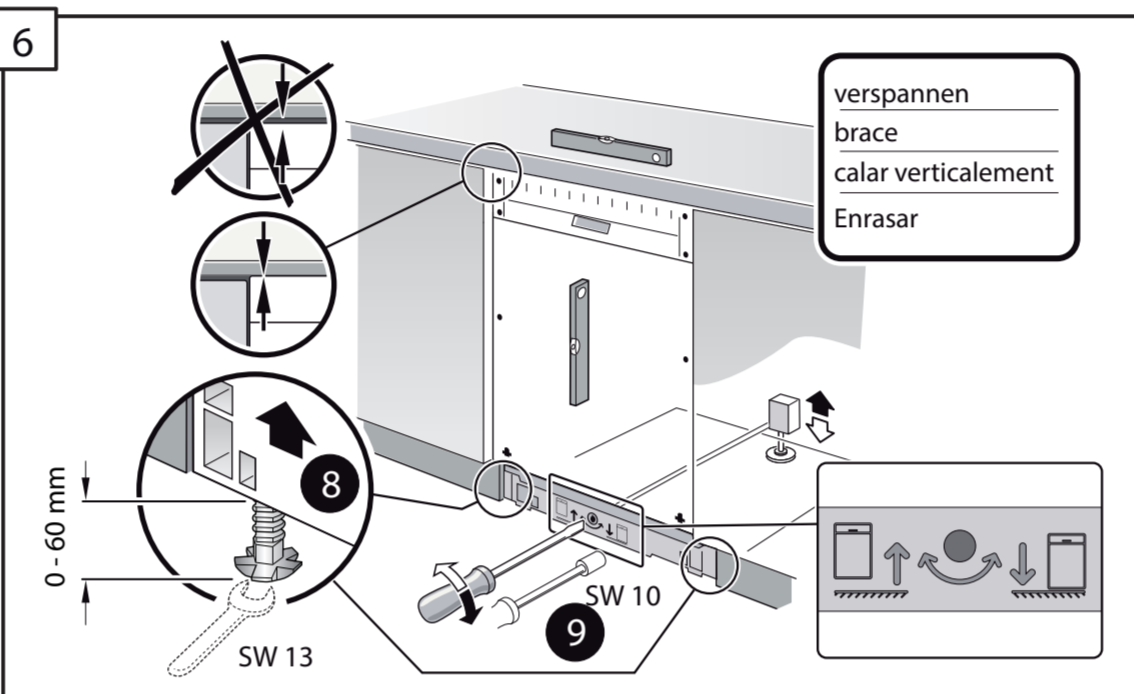
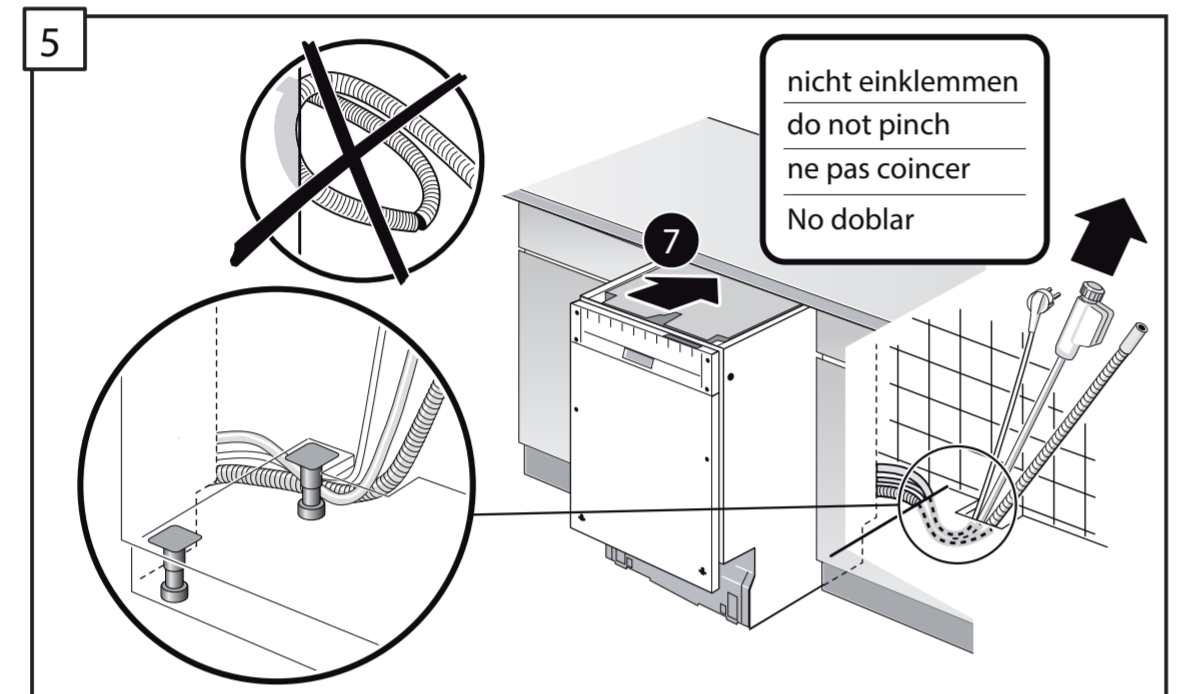
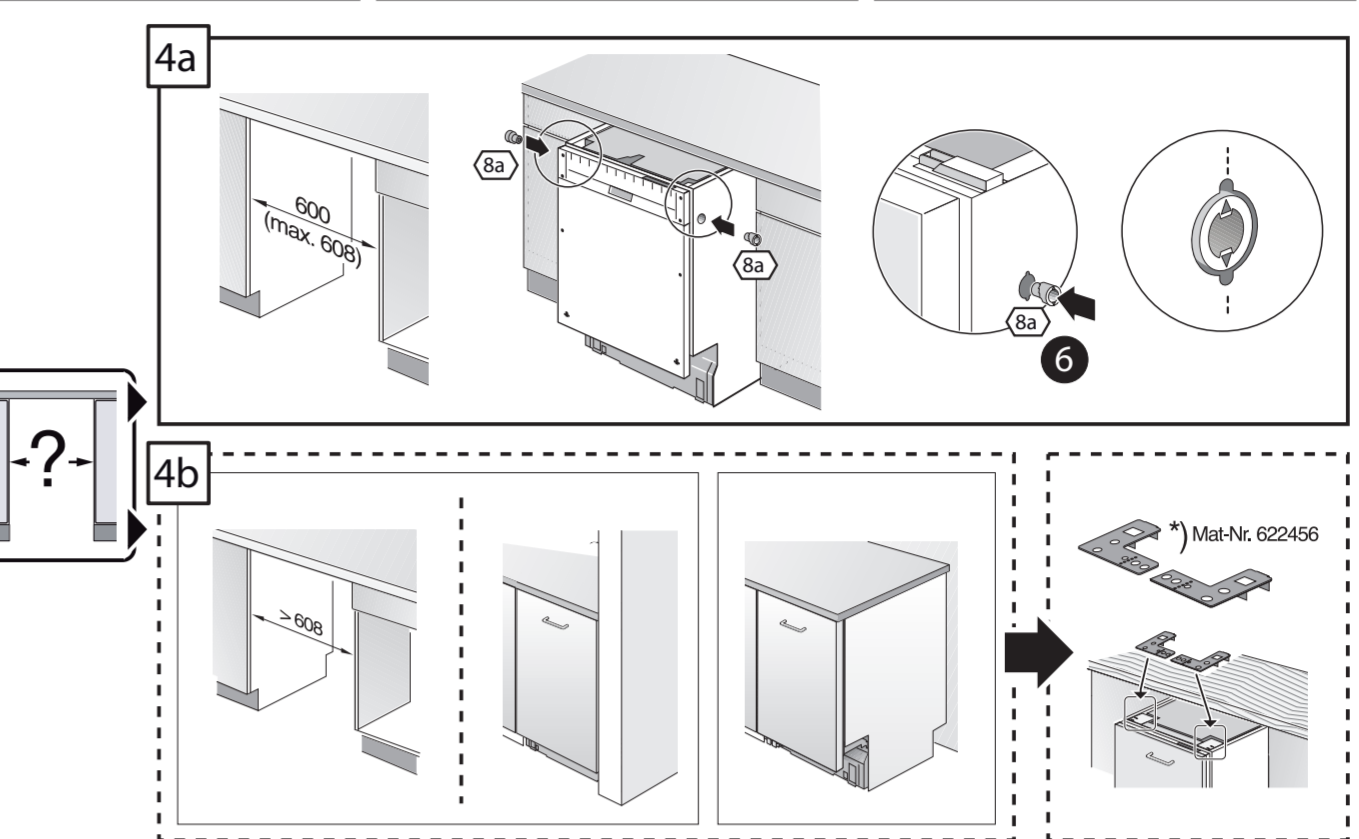
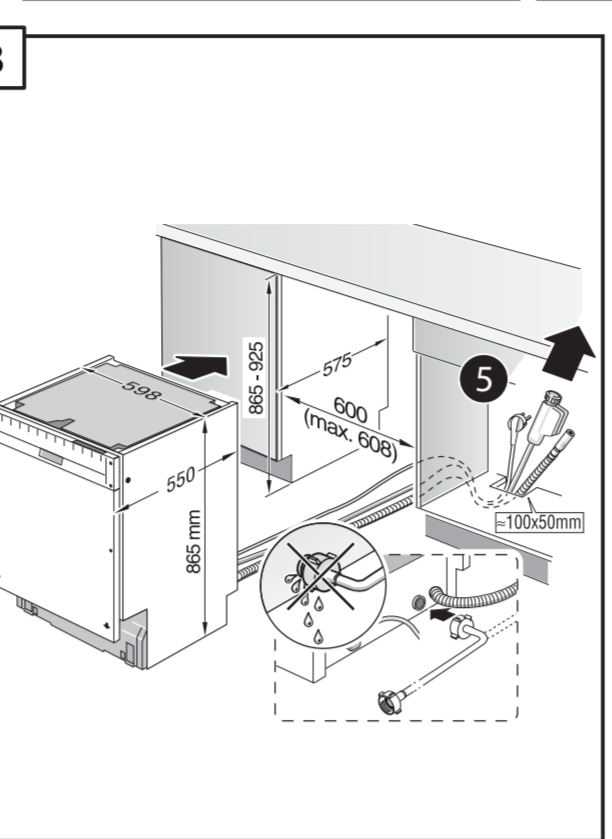
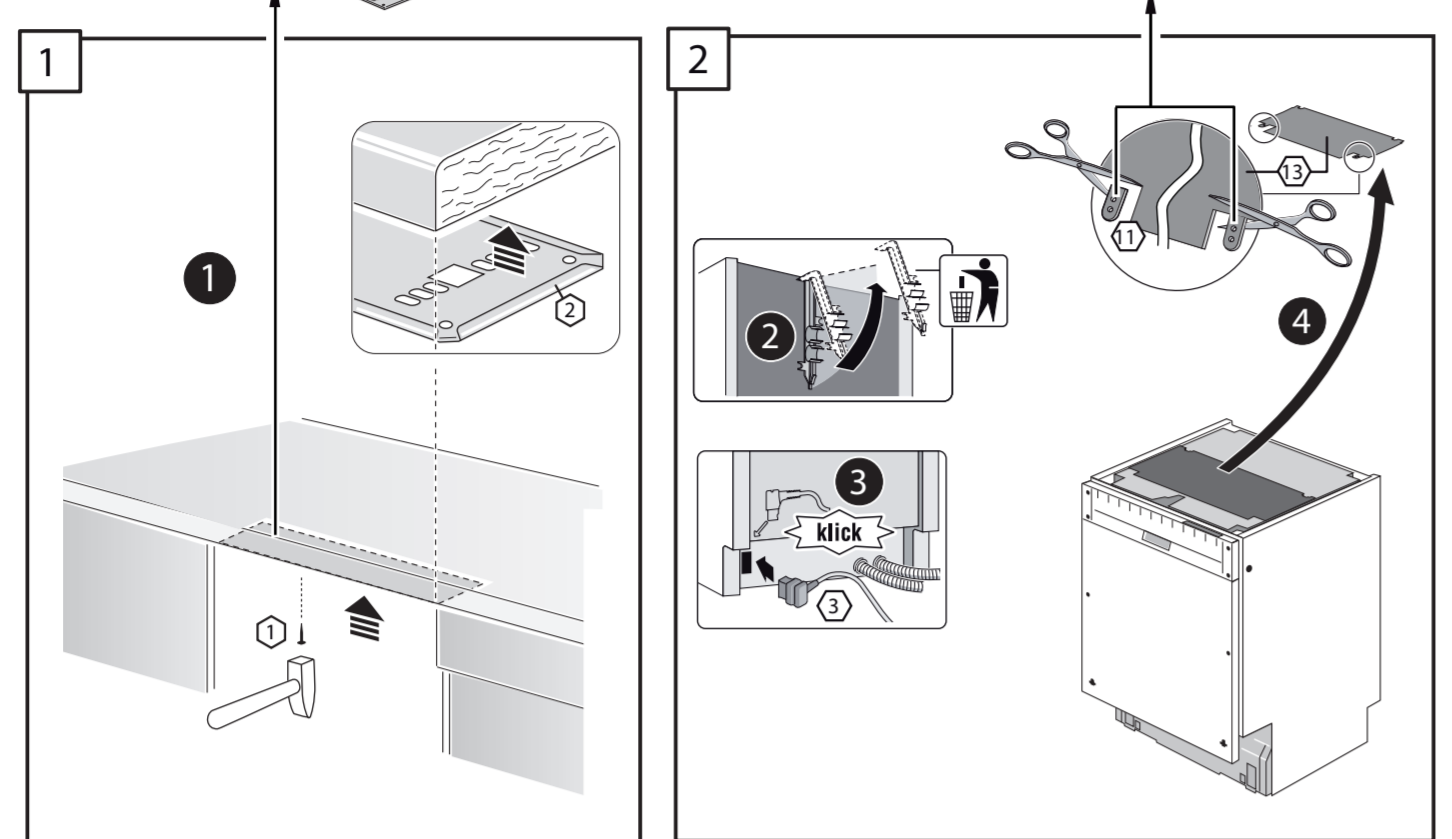

de Montageanleitung
 *) über Kundendienst erhältlich
en Installation instructions
 *) Available from customer service
fr Notice de montage
 *) Disponible par le biais du service après-vente
nl Montagevoorschrift
 *) Tegen meerprijs bij de Servicedienst verkrijgbaar
it Istruzioni per il montaggio
 *) Disponibili presso il servizio assistenza clienti
sk Odborný vzorčák
 *) Uplatňuje sa na vybrané typy výrobkov (špeciálne príslušenstvo)
es Instrucciones de montaje *) Se puede adquirir a través del Servicio de Asistencia Técnica Oficial de la marca
pt Instruções de montagem
 *) Pode ser adquirido nos nossos Serviços Técnicos
sv Monteringsanvisning
 *) Kan fås via Service
tr Montaj kılavuzu
 *) Yetkili servis üzerinden alınabilir
ru Инструкция по монтажу
 *) Можно получить в сервисном центре
cs Montážní návod
 *) K dispozici přes servisní službu
no Monteringsanvisning
 *) fåes hos kundeservice
fi Asemusohje
 *) Saatavissa huoltoasemasta
da Monteringsvejledning
 *) Kan købes hos serviceafdelingen
pl Instrukcja montażu
 *) Do uzyskania w punkcie serwisowym
hu Szerelési utasítás
 *) A végszolgáltatón keresztül kapható:
lv Uputa za montažu
 *) može dobiti kod službe održavanja
mk Упутство за монтажа
 *) се добија преку служба за купувачи
sl Navodilo za montažo
 *) lahko nabavite v servisni službi
sr Uputstvo za montažu
 *) Može se nabaviti preko servisne službe
et Monteerimisjuhend
 *) küsige klienditeenindusest
lt Montavimo instrukcija
 *) ją galima gauti klientų aptarnavimo servise
lv Montāžas pamācība
 *) Var saņemt servisa dienestā
skj Návod na montáž
 *) Dostanete v službe zákazníkom
hr Udhuzues për montim
 *) Sigurohet nëpërmjet servisit
bs Uputa za montažu
 *) Može se dobiti preko servisne službe
fa راهنمای مونتاژ
 *) از مرکز خدمات پس از فروش تهیه فرمایید
ar تعليمات التركيب
 *) يمكن طلبها من مراكز خدمة العملاء
ko 설치 설명서
 *) 고객서비스 센터에서 구입 가능
zh 安装说明书
 *) 可向售后服务站索取
uk Інструкція з монтажу
 *) Можна отримати через сервісну службу
ru Инструкция de montaj
 *) obținabilă la serviciul pentru clienți
id Instruksi Pemasangan
 *) bisa didapatkan melalui Customer Service
kk Іске қосу туралы нұсқаулар!
 *) Сервис қызметі көрсету орталығында алуға жағдай

nicht einklemmen
do not pinch
ne pas coincer
No doblar

verspannen
brace
calar verticalmente
Enrasar

einstellen
adjust
régler
ajustar

c =	d =
700 mm	iv 30 mm
710 mm	iv 20 mm
720 mm	iv 10 mm
730 - 775 mm	iv 0 mm

Scheibe entfernen
remove disc
enlever le disque
Eliminar disco

max. 10 Nm

Dichtheit nach einem Spülgang prüfen.
Check for leaks after one wash cycle.
Vérifiez l'étanchéité après un lavage.
Verificar la estanqueidad tras un ciclo de lavado.

3 m EU *) Mat.-Nr. 644533

3 m GB *) Mat.-Nr. 644534

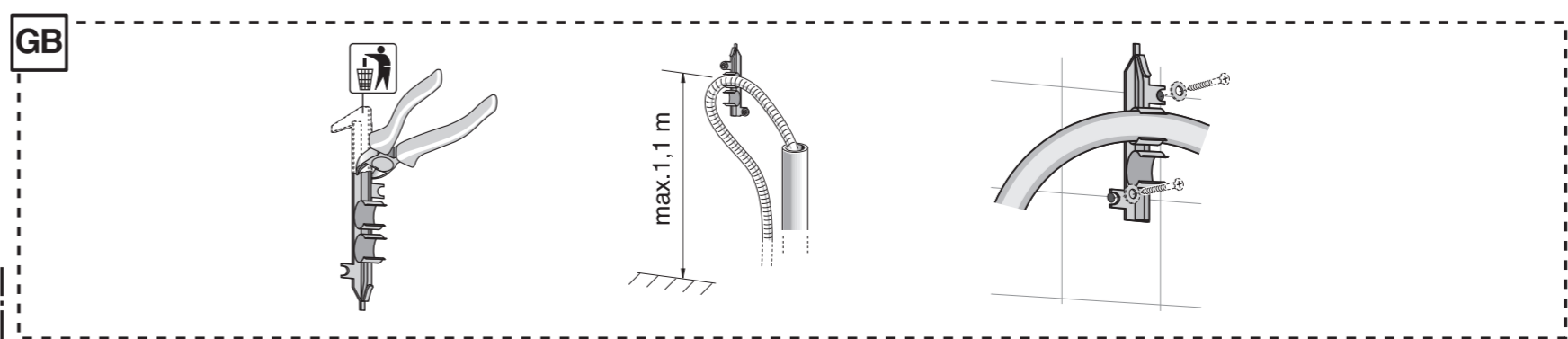

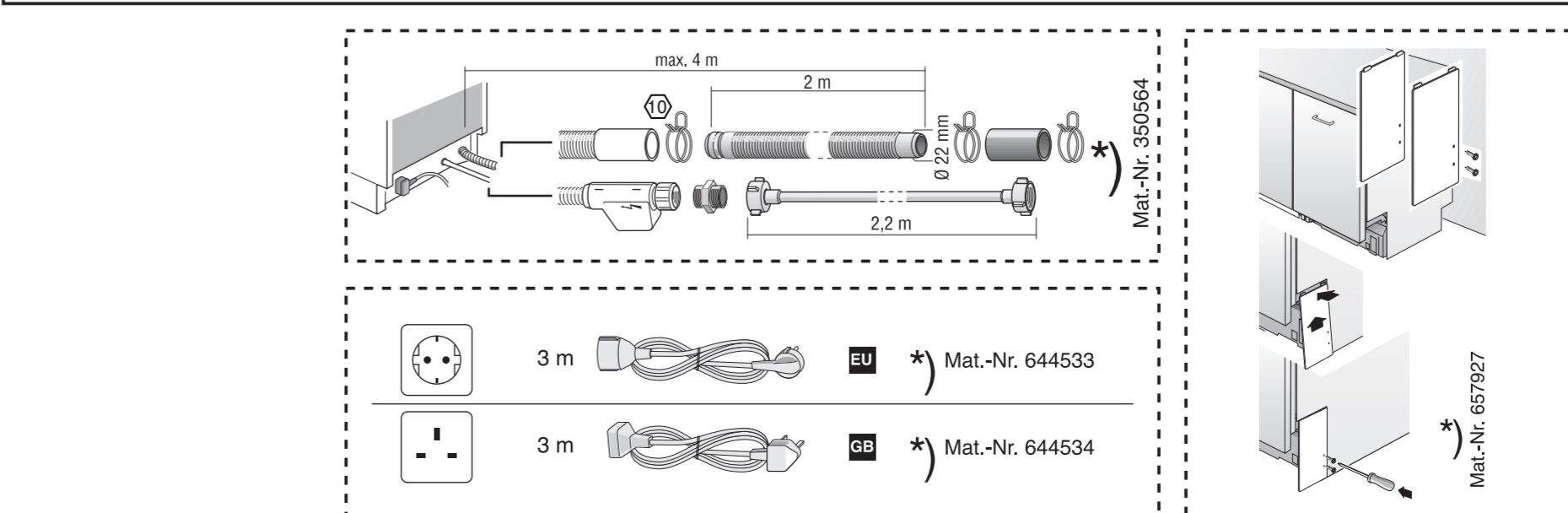
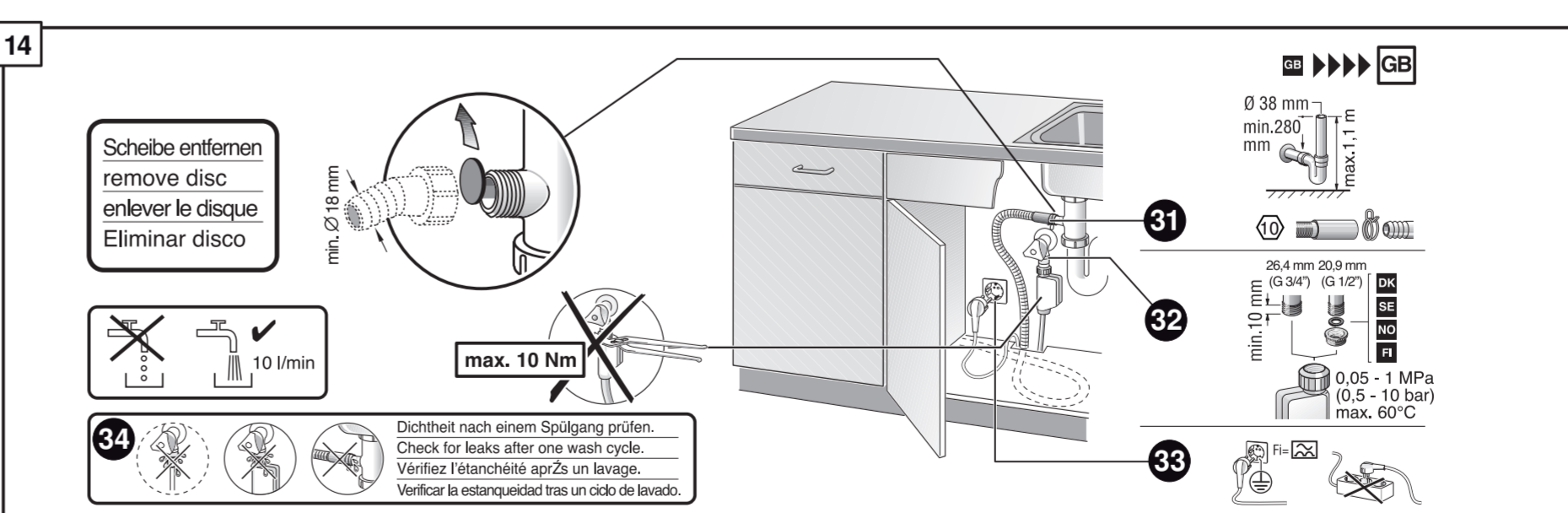
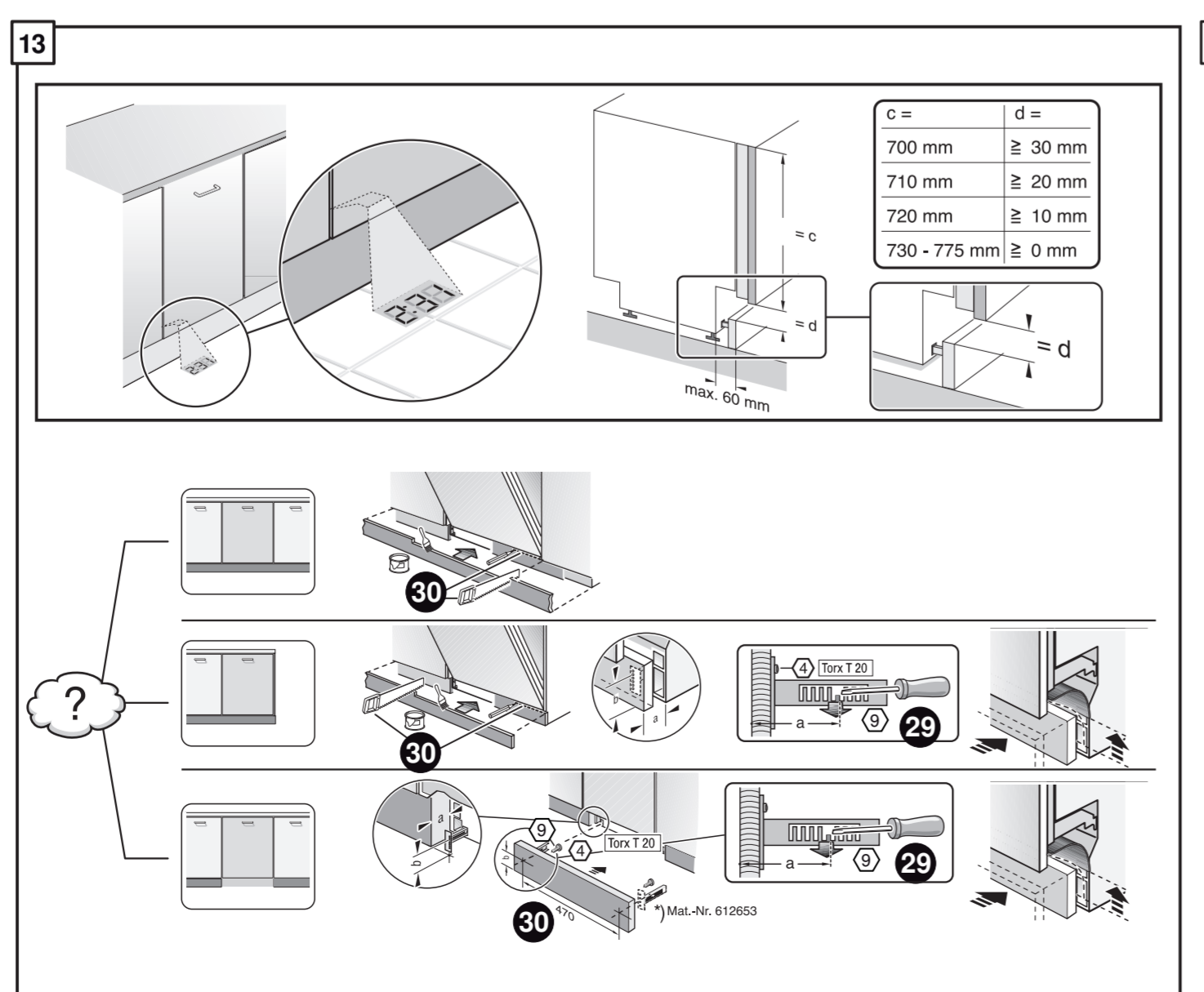
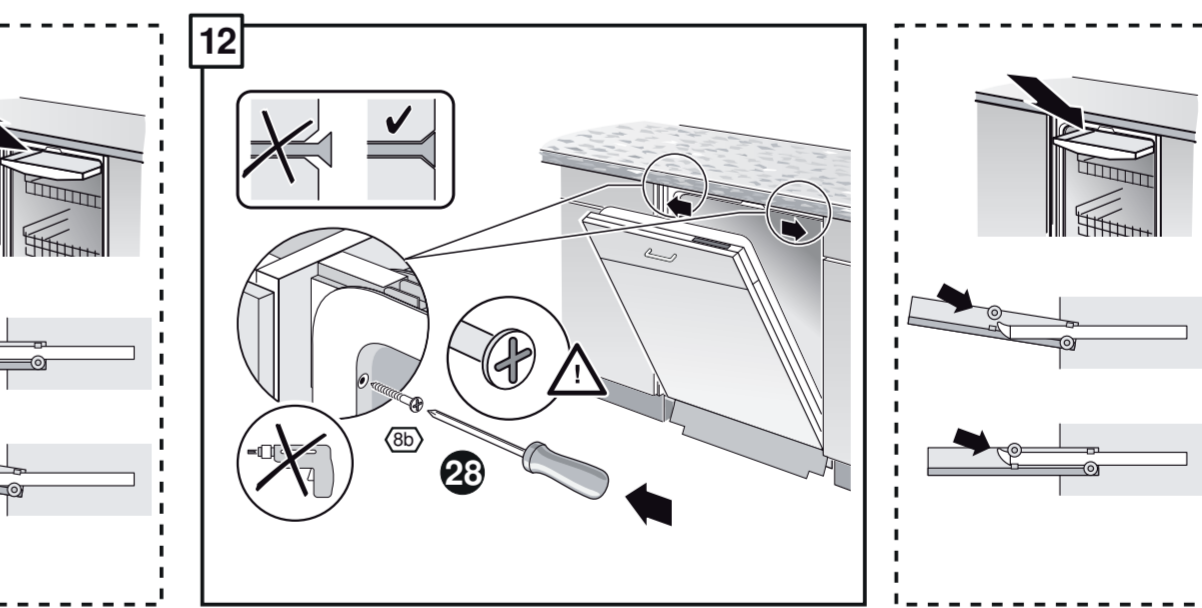
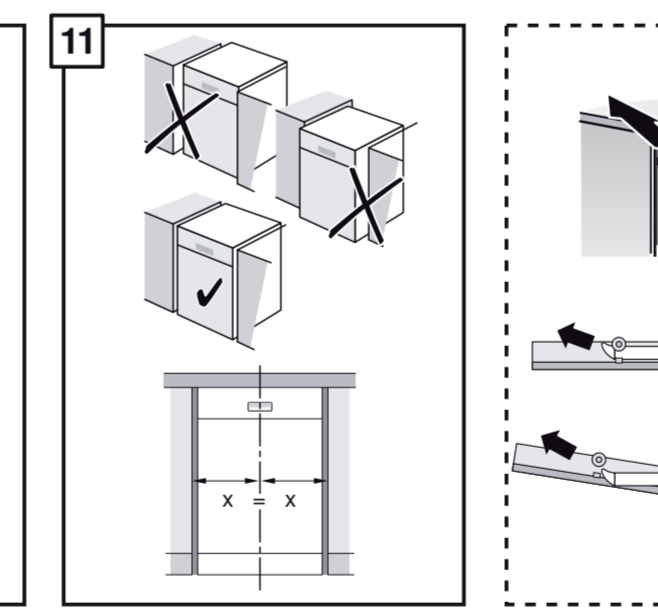
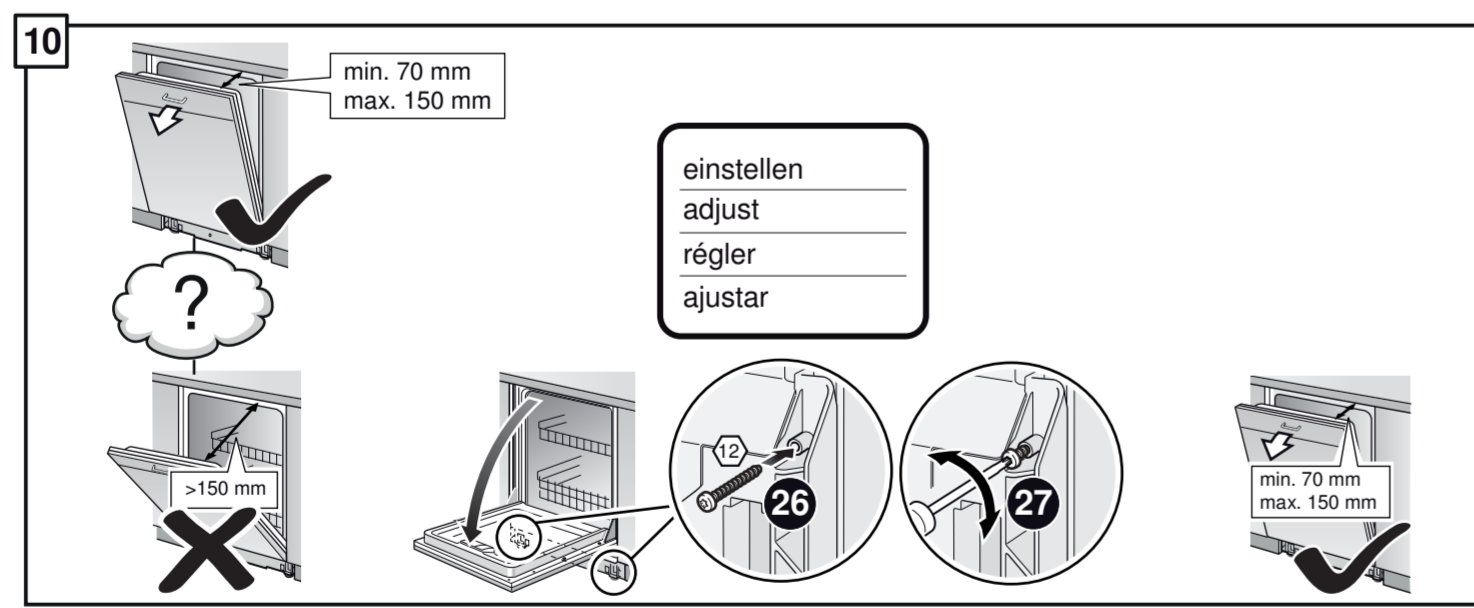
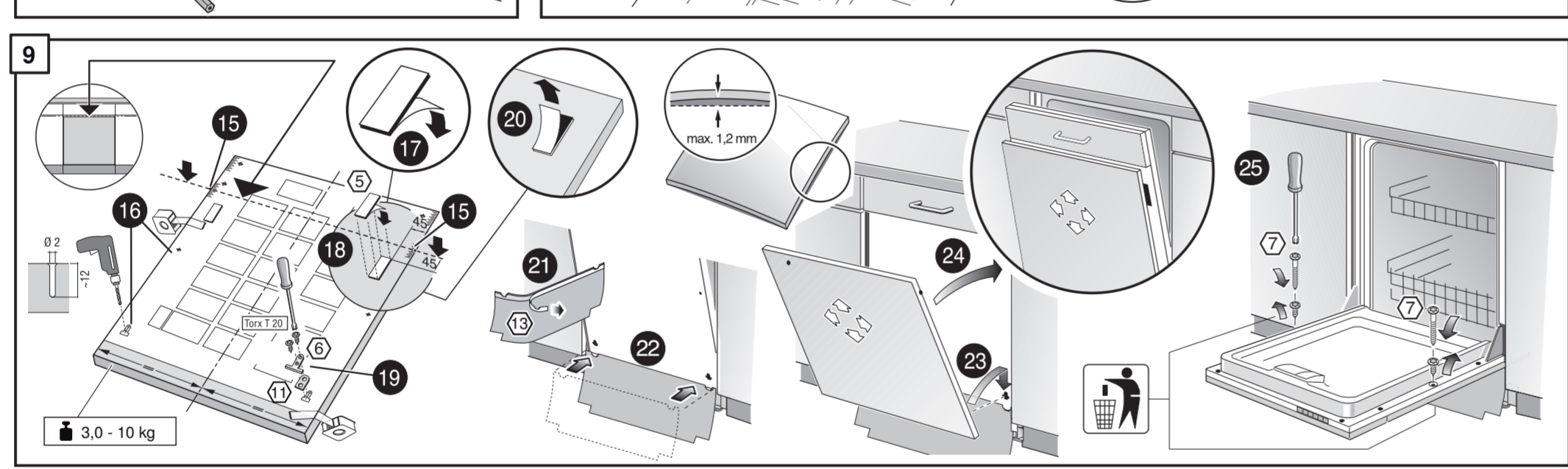
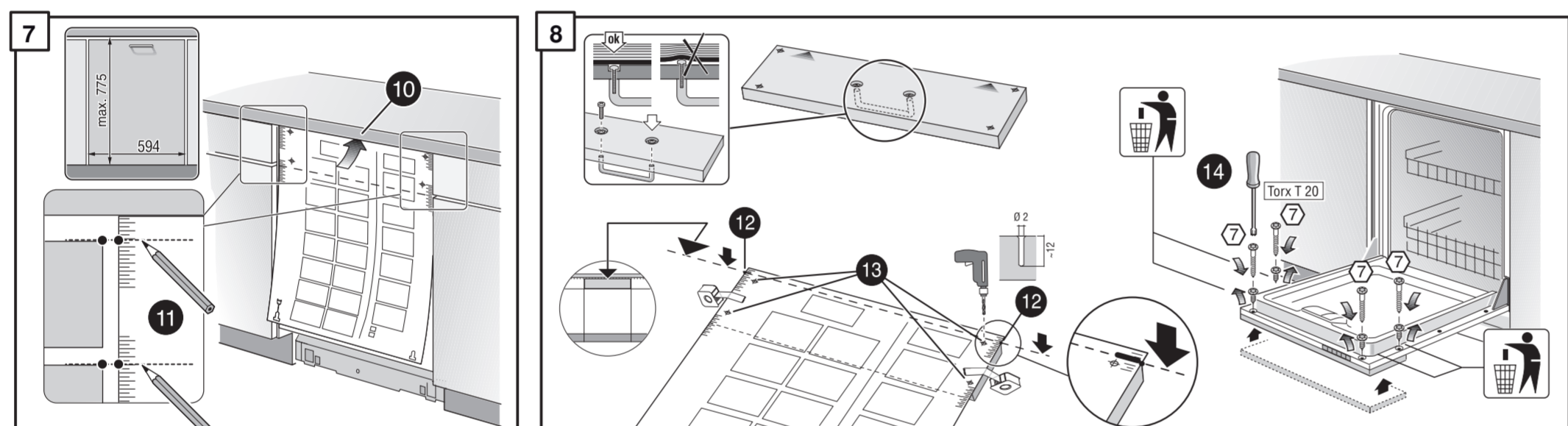
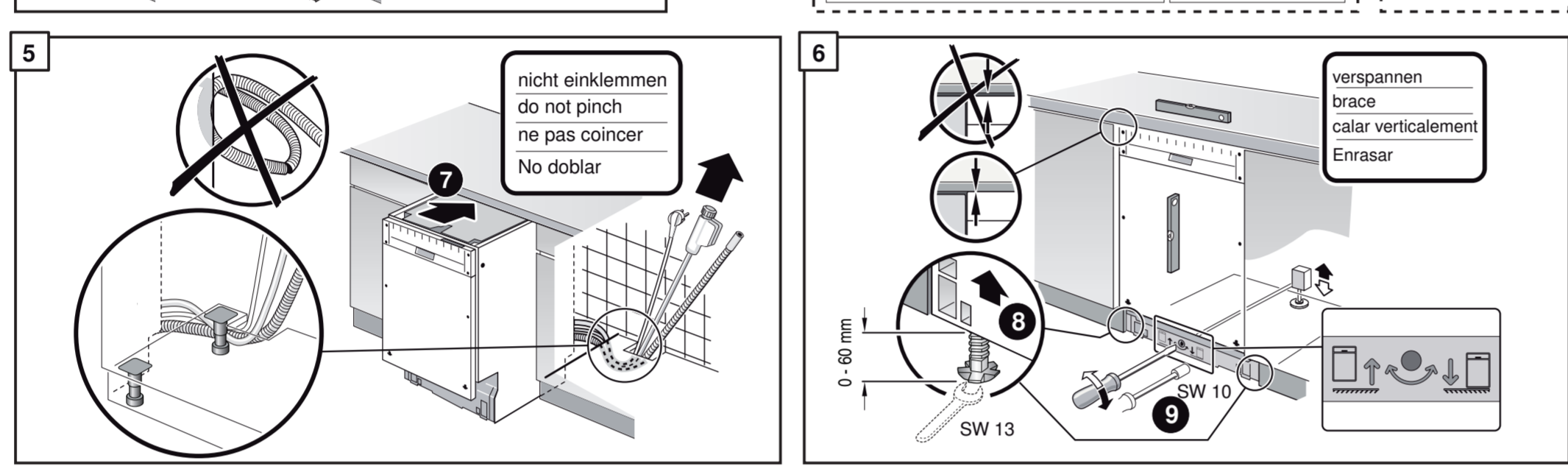
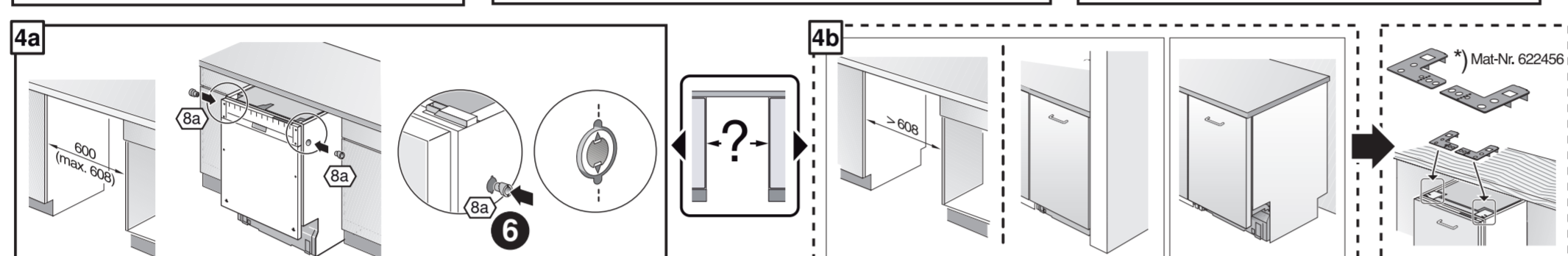
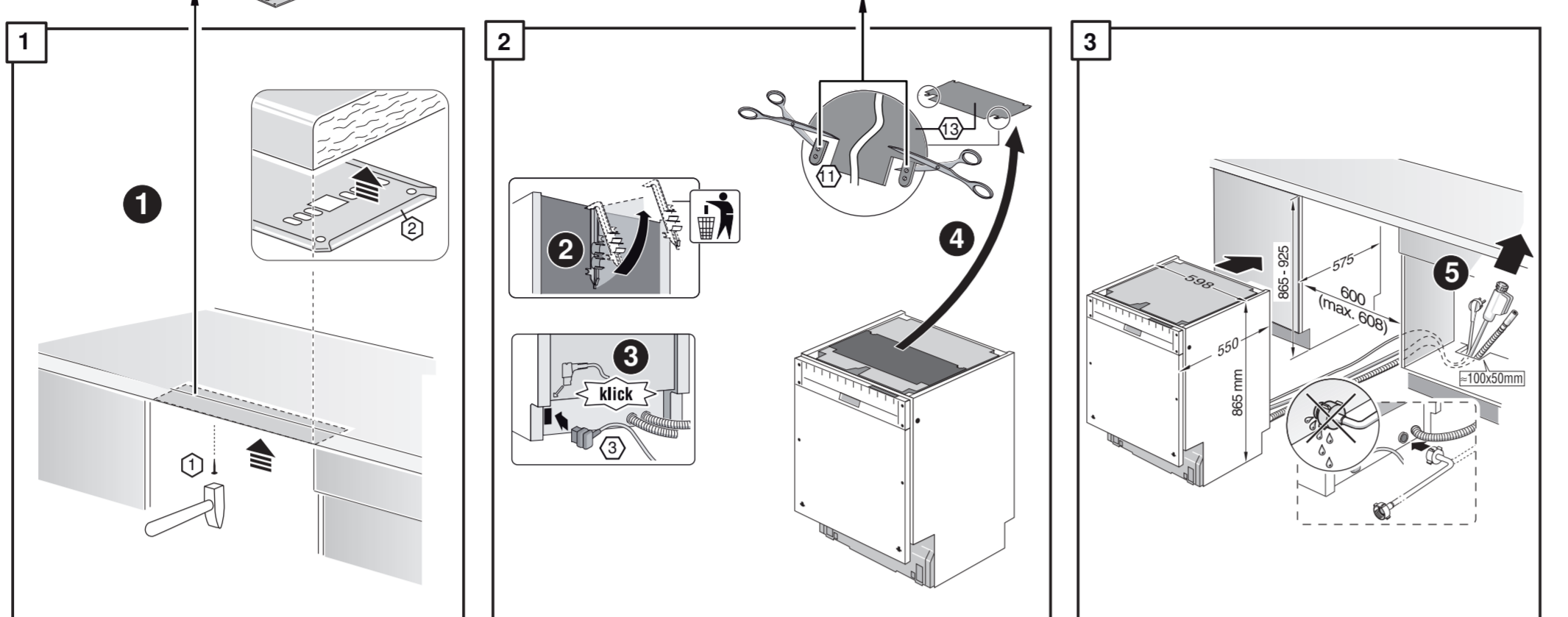
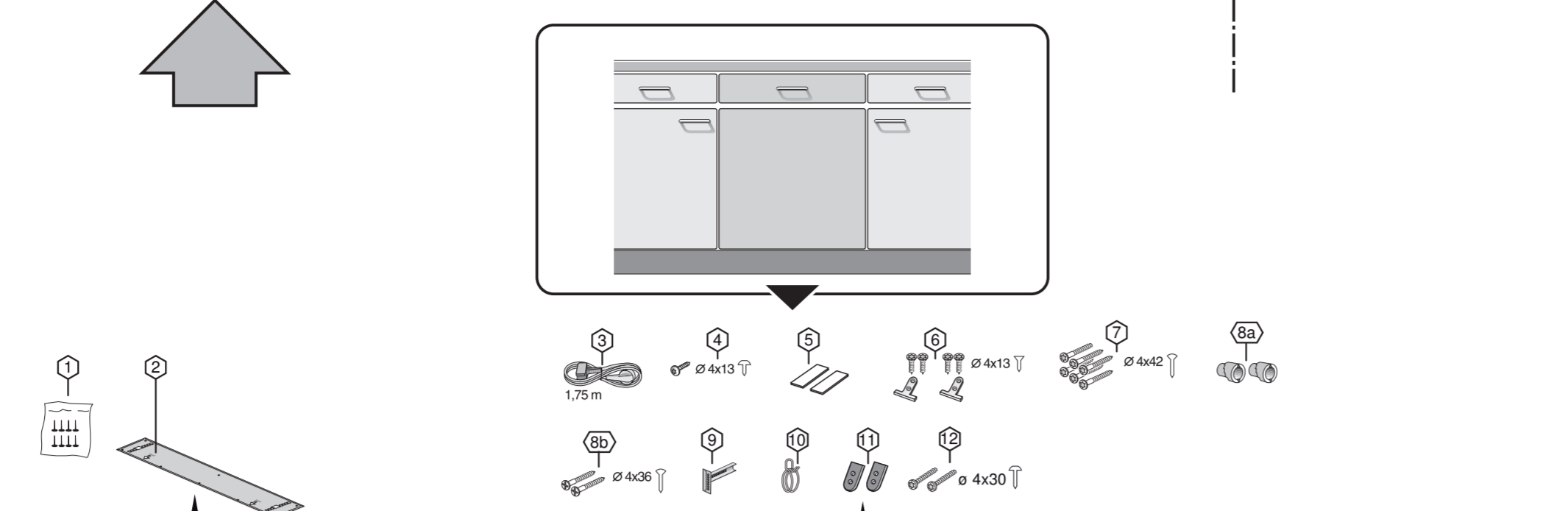
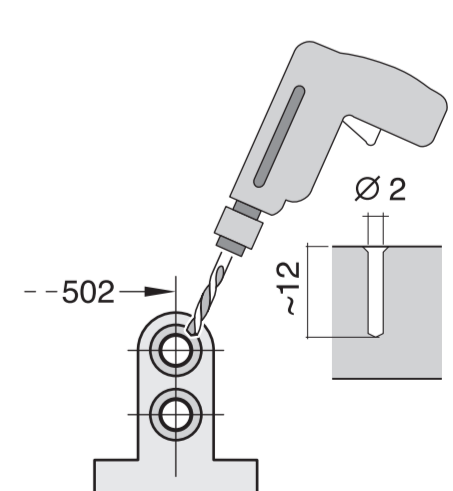
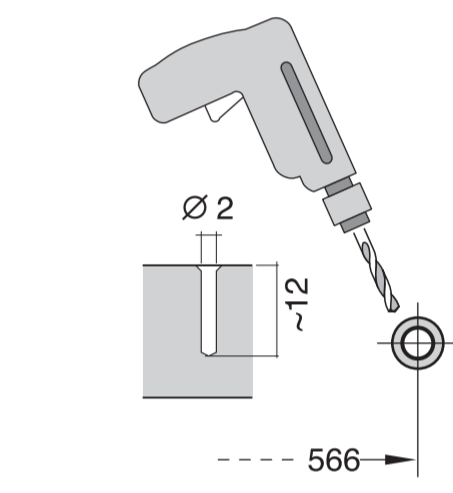
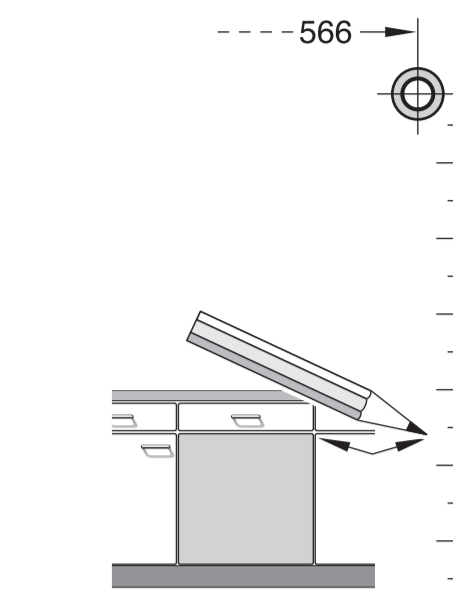
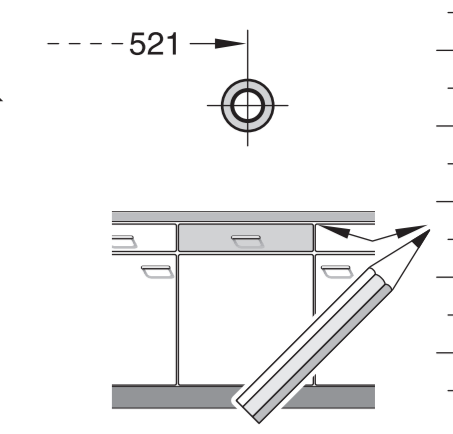
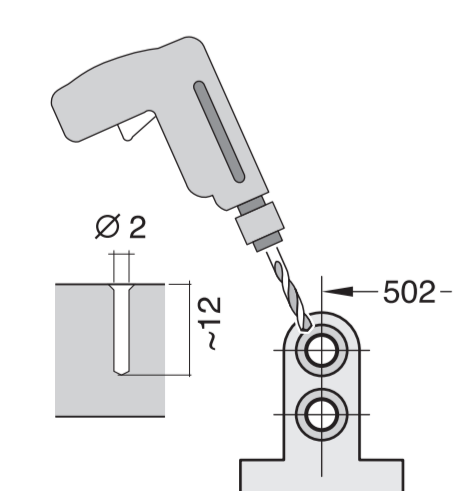
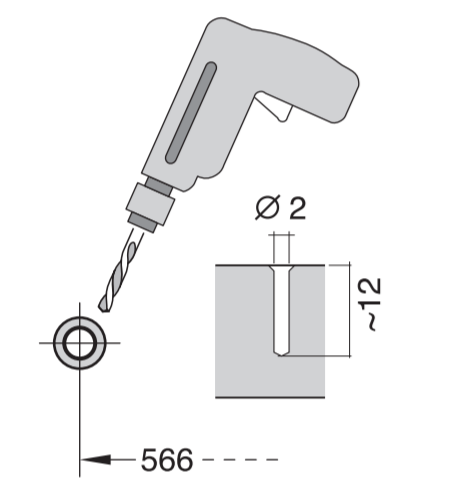
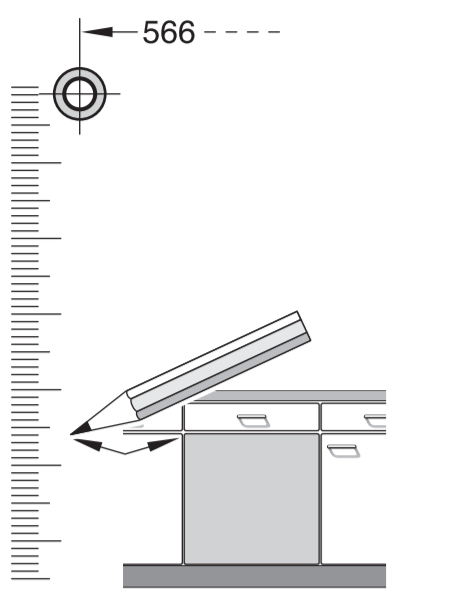
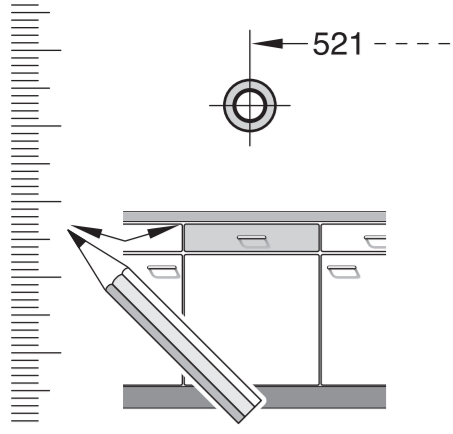

1
6
7a

8a

9a

10 >>> 14

GB

Mat.-Nr. 350564

EU

Mat.-Nr. 644533

GB

Mat.-Nr. 644534

Mat.-Nr. 657927