

de Montageanleitung
 *) über Kundendienst erhältlich
en Installation instructions
 *) Available from customer service
fr Notice de montage
 *) Disponible par le biais du service après-vente
nl Montagevoorschrift
 *) Tegen meerprijs bij de Servicedienst verkrijgbaar
it Istruzioni per il montaggio
 *) Disponibili presso il servizio assistenza clienti
sl Obnavila varnostne
 *) Dostopna na plačilo naročnika
es Instrucciones de montaje *) Se puede adquirir a través del Servicio de Asistencia Técnica Oficial de la marca
pt Instruções de montagem *) Pode ser adquirido nos nossos Serviços Técnicos
sv Monteringsanvisning *) Kan fås via Service
tr Montaj kilavuzu
 *) Yetkili servis üzerinden alınabilir
ru Инструкция по монтажу *) Можно получить в сервисном центре
cs Montážní návod *) K dispozici přes servisní službu
no Monteringsanvisning *) fåes hos kundeservice
fi Asemusohje *) Saatavissa huoltoasemasta
da Monteringsvejledning *) Kan købes hos serviceafdelingen
pl Instrukcja montażu *) Do uzyskania w punkcie serwisowym
hu Szerelési utasítás *) A végszolgáltatón keresztül kapható:
lv Uputa za montažu *) Može dobiti kod službe održavanja
mk Упатство за монтажа *) Се добива преку службата за купувачи
sl Navodilo za montažo *) Lahko nabavite v servisni službi
sr Uputstvo za montažu *) Može se nabaviti preko servisne službe
et Monteerimisjuhend *) Küsige klienditeeninduselt
lt Montavimo instrukcija *) Gali gauti paslaugų klientų aptarnavimo servise
lv Montāžas pamācība *) Var saņemt servisa dienestā
sk Návod na montáž *) Dostanete v službe zákazníkom
cl Udhæuzes pør montim *) Sigurohet nãpørmiyet servisit
lv Uputa za montažu *) Može se dobiti preko servisne službe
fa راهنمای مونتاژ *) از مراکز خدمات پس از فروش تهیه فرمایید
ar تعليمات التركيب *) يمكن طلبها من مراكز خدمة العملاء
ko 설치 설명서 *) 고객센터 센터에서 구입 가능
zh 安装说明书 *) 可向售后服务站索取
uk Інструкція з монтажу *) Можна отримати через сервісну службу
id Instruksi Pemasangan *) bisa didapatkan melalui Customer Service
kk Іске хосу туралы нұсқаулар! *) Сервис қызметі көрсету орталығында алуға жағдай

GV 640 Voll-I - 81,5 cm - m. GS 9001 107 564 (9505)

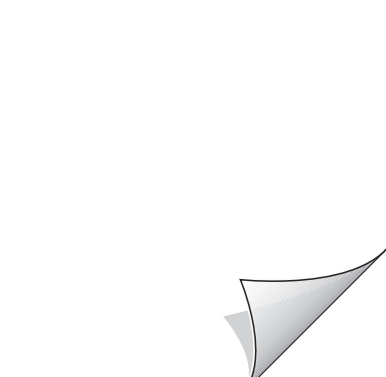

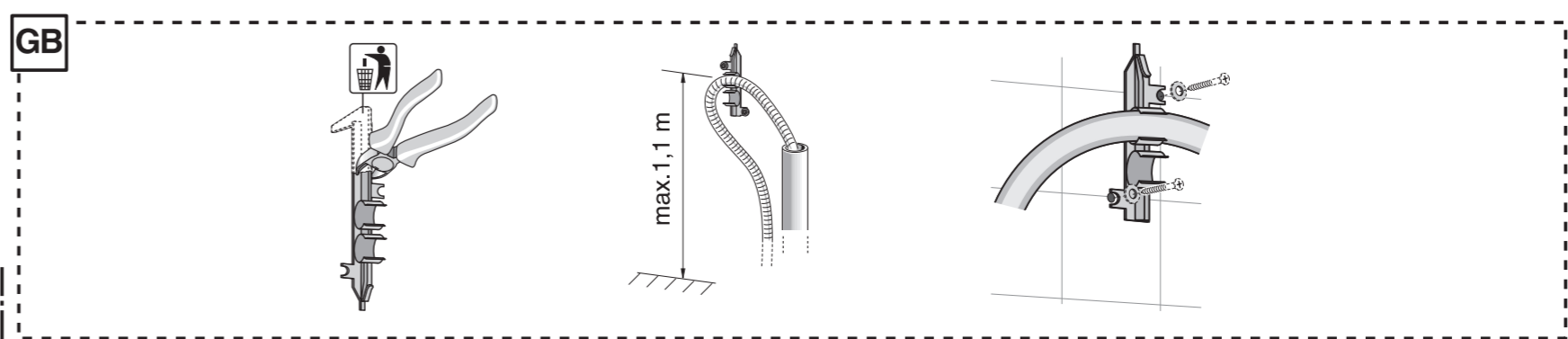
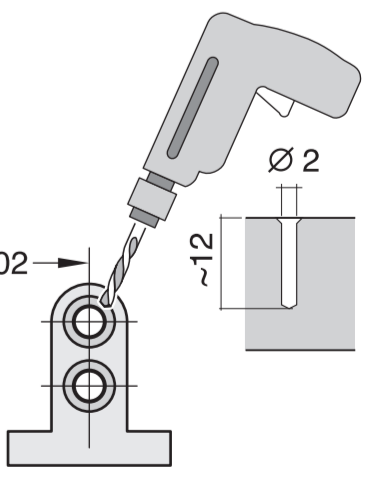
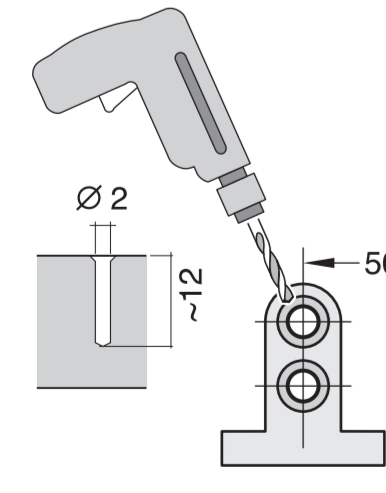
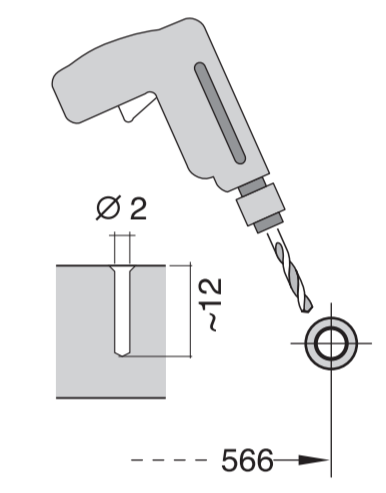
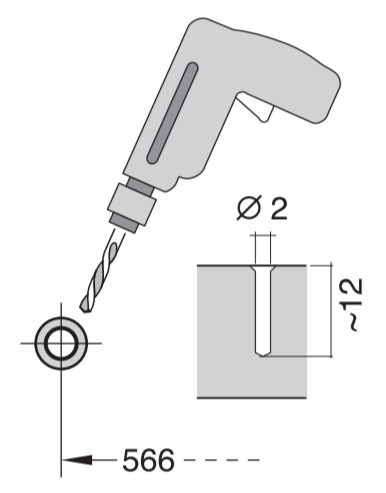
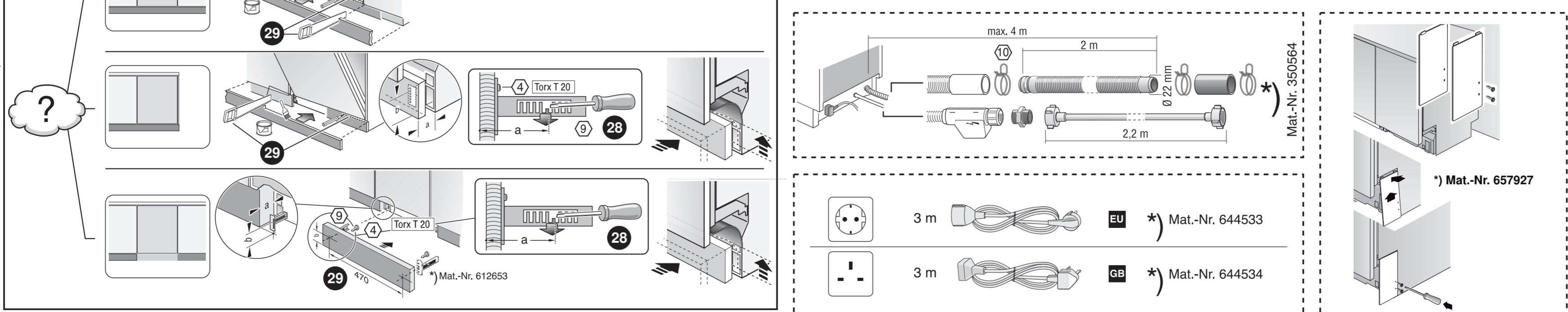
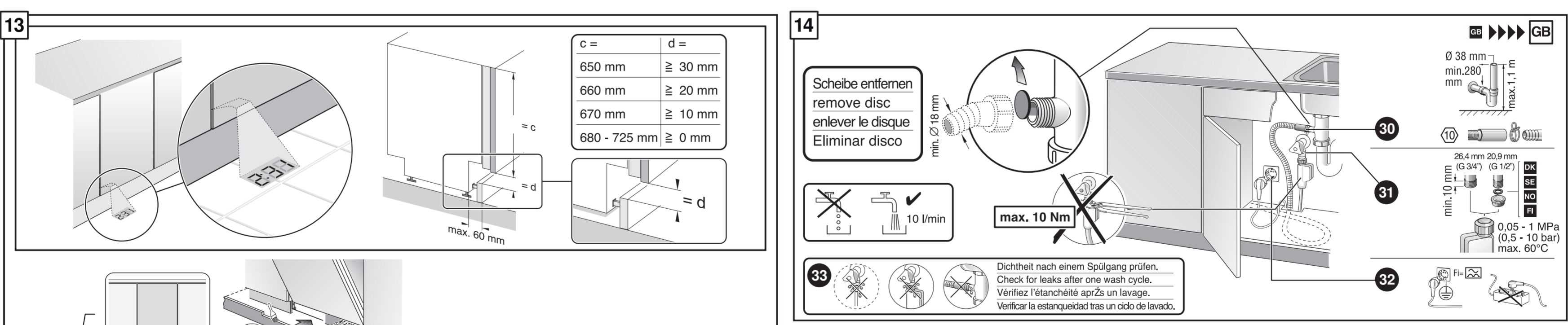
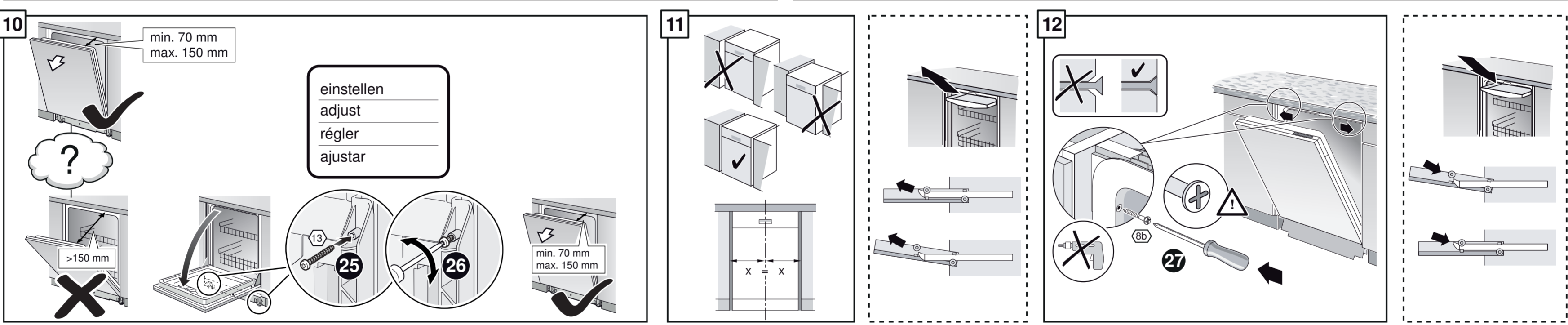
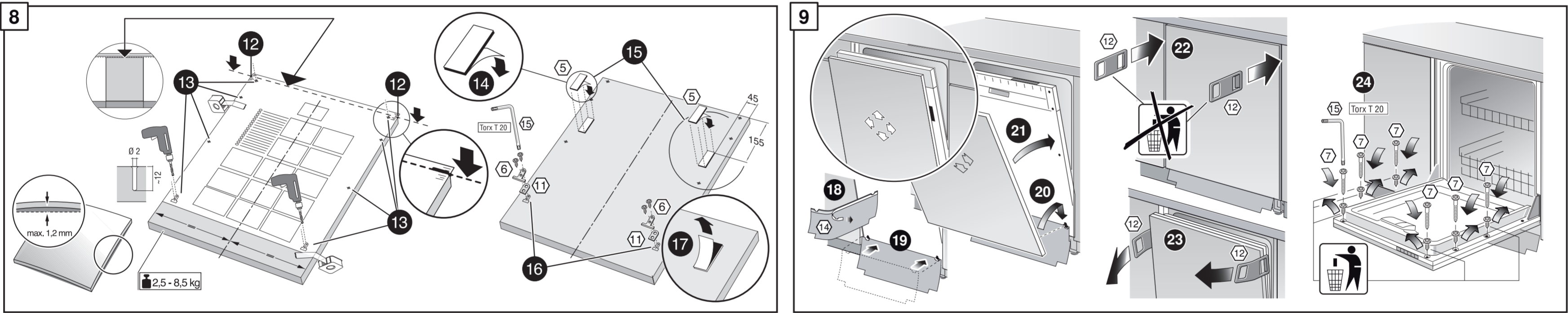
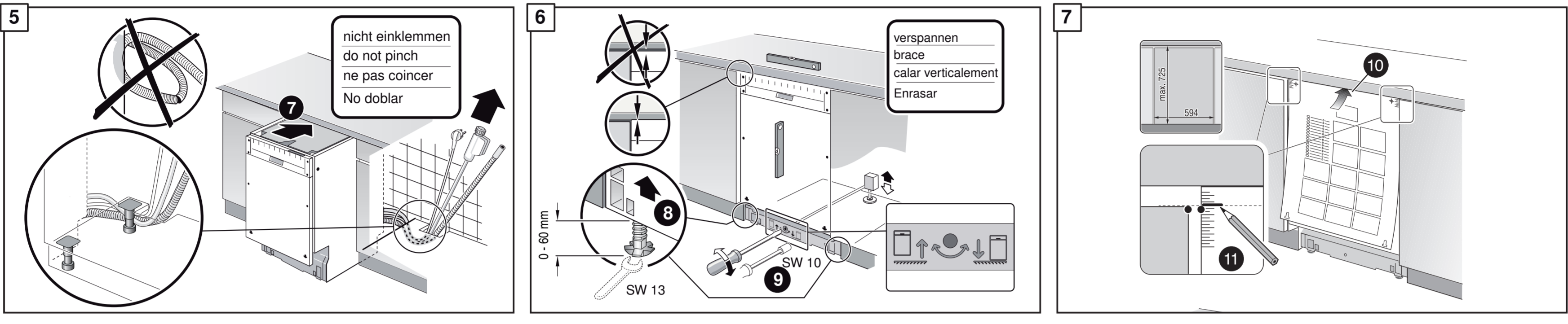
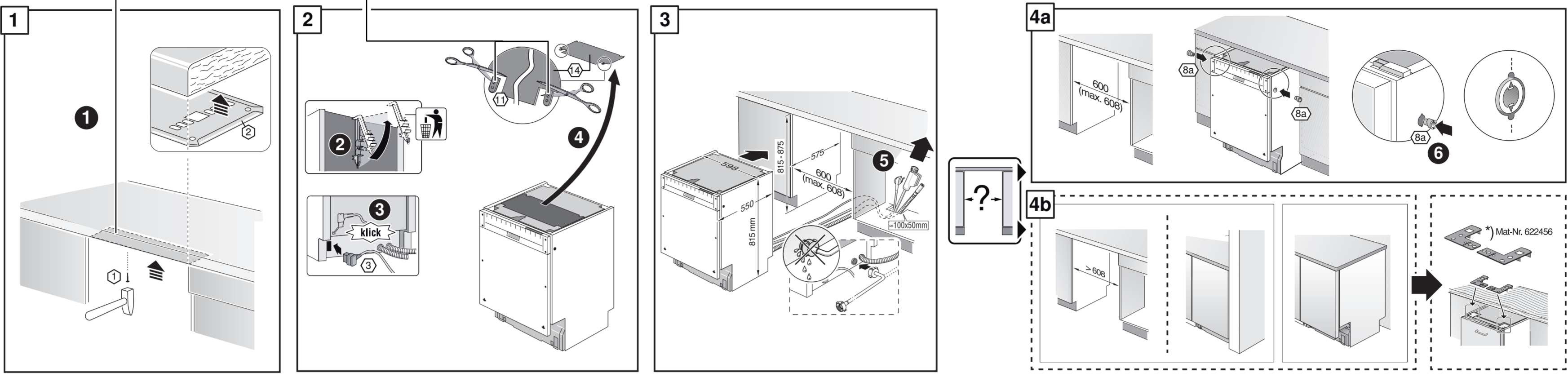
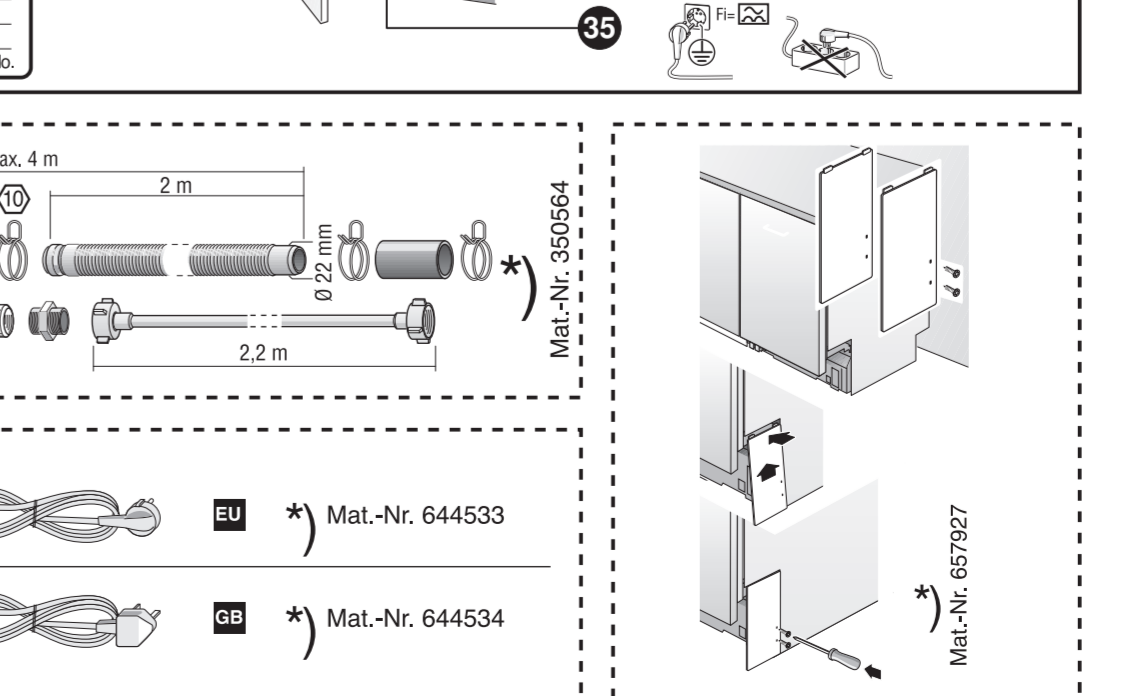
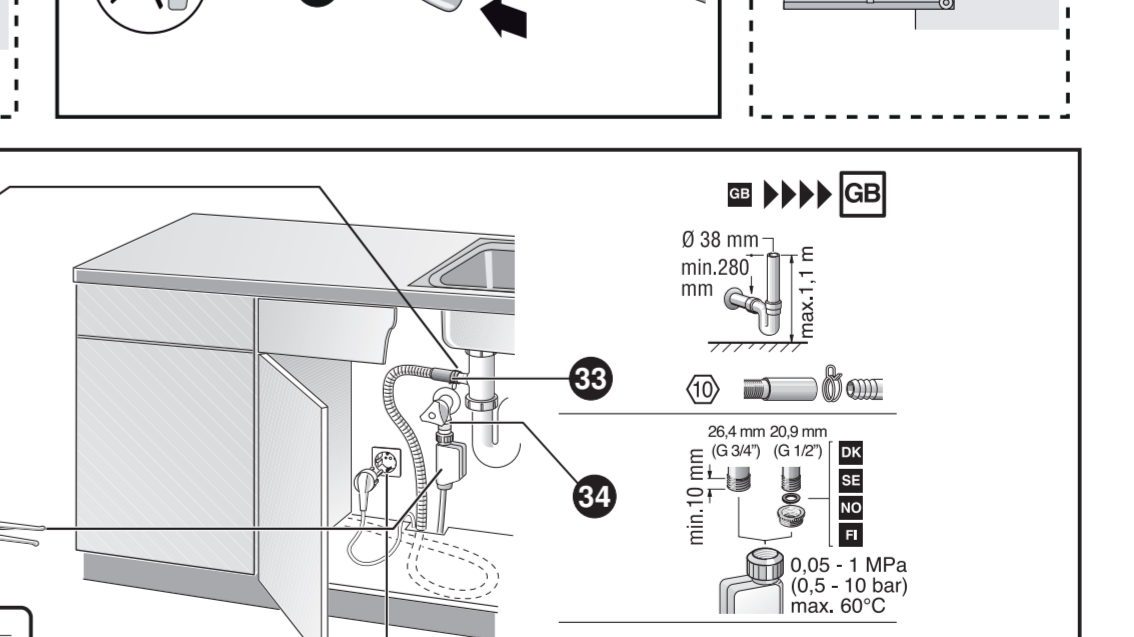
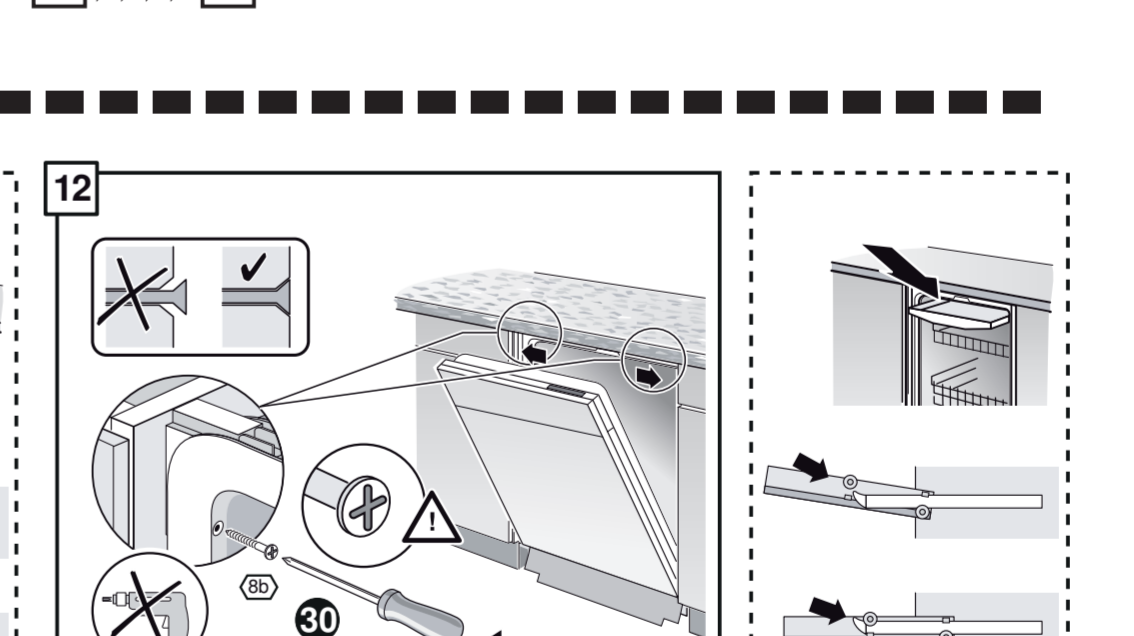
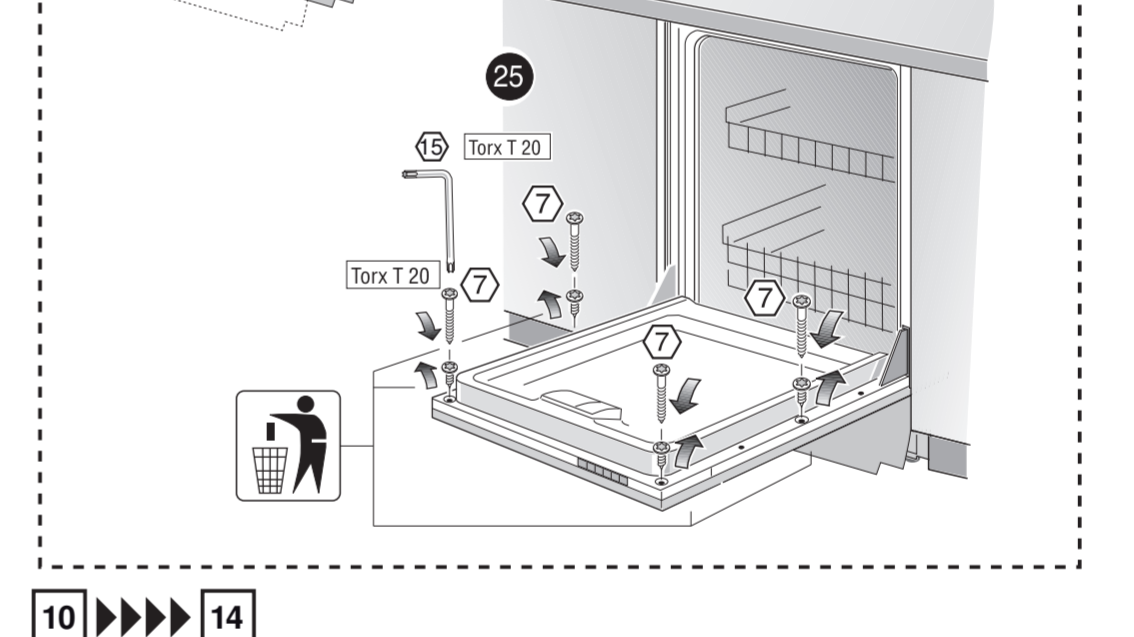
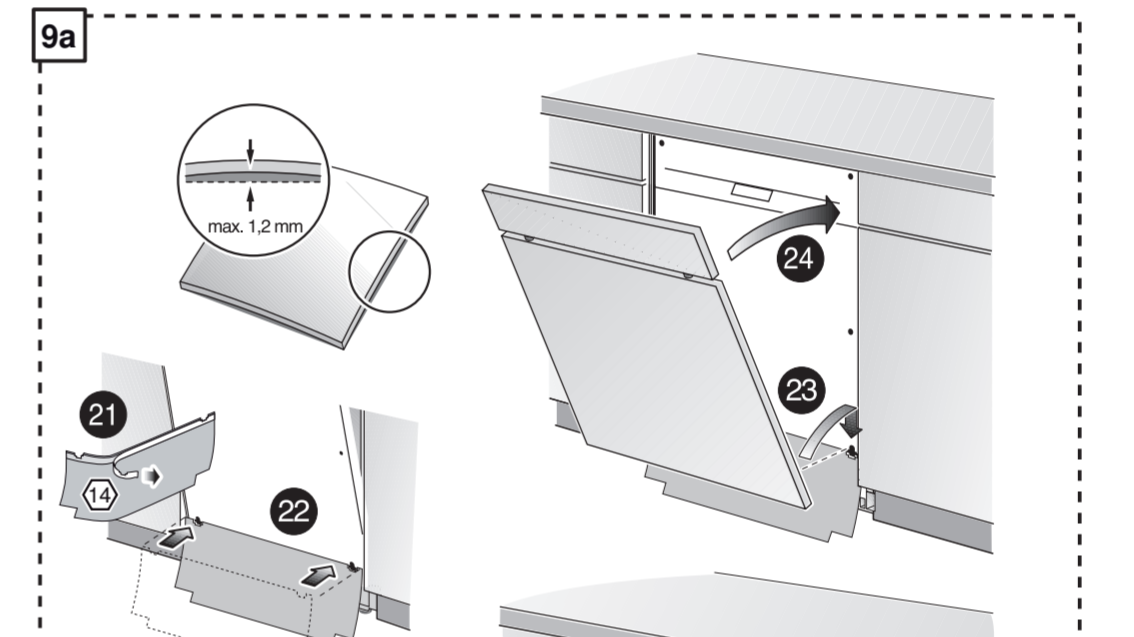
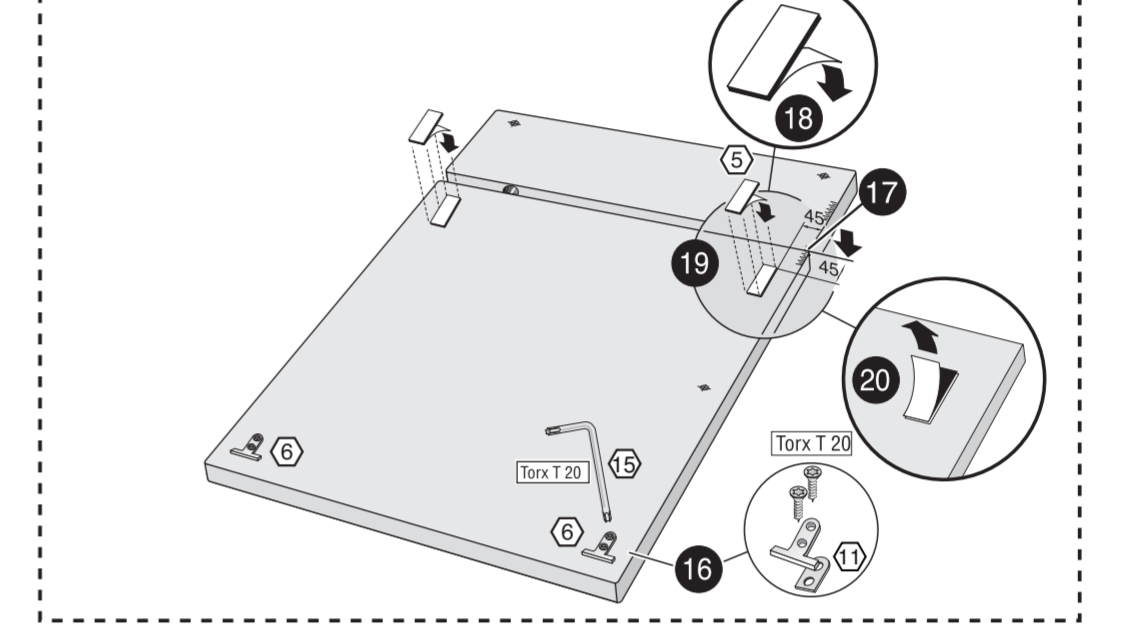
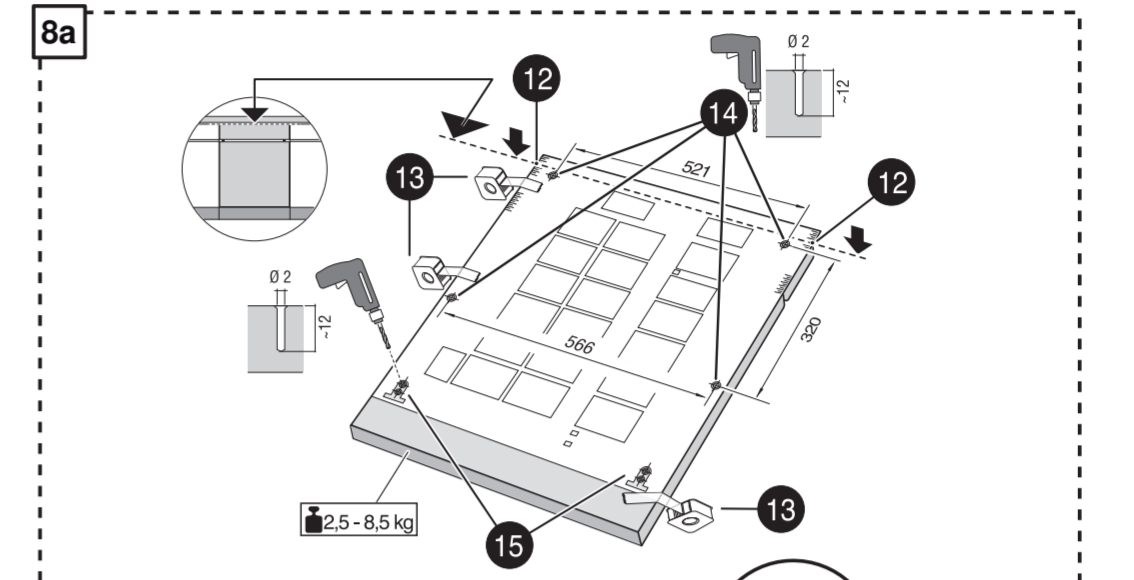
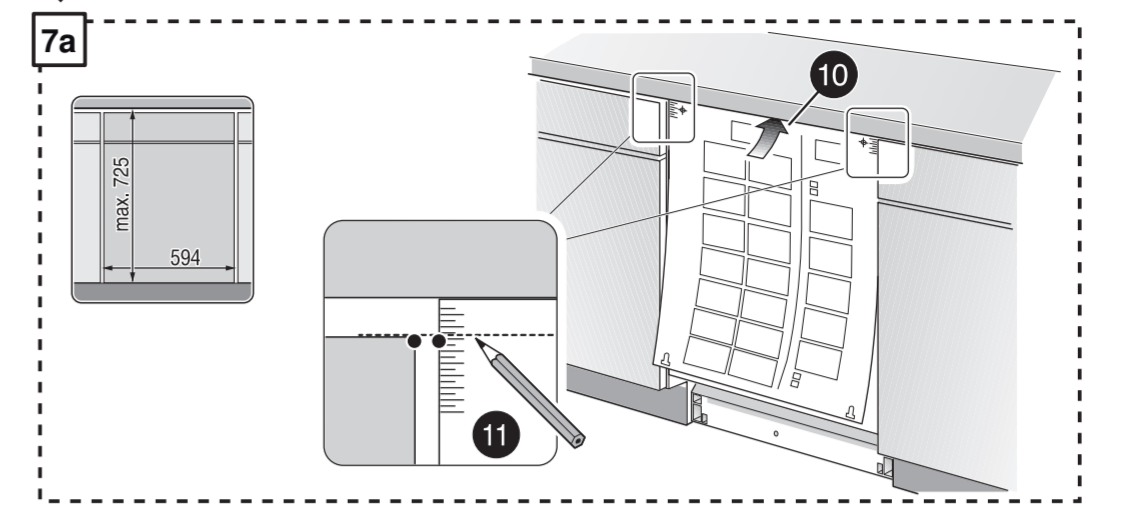
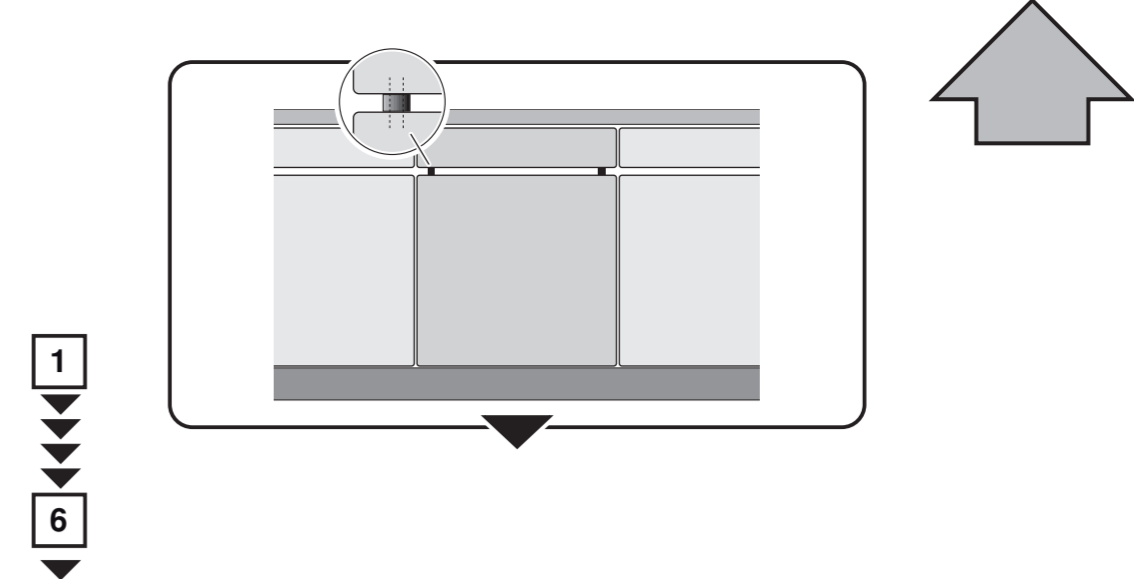
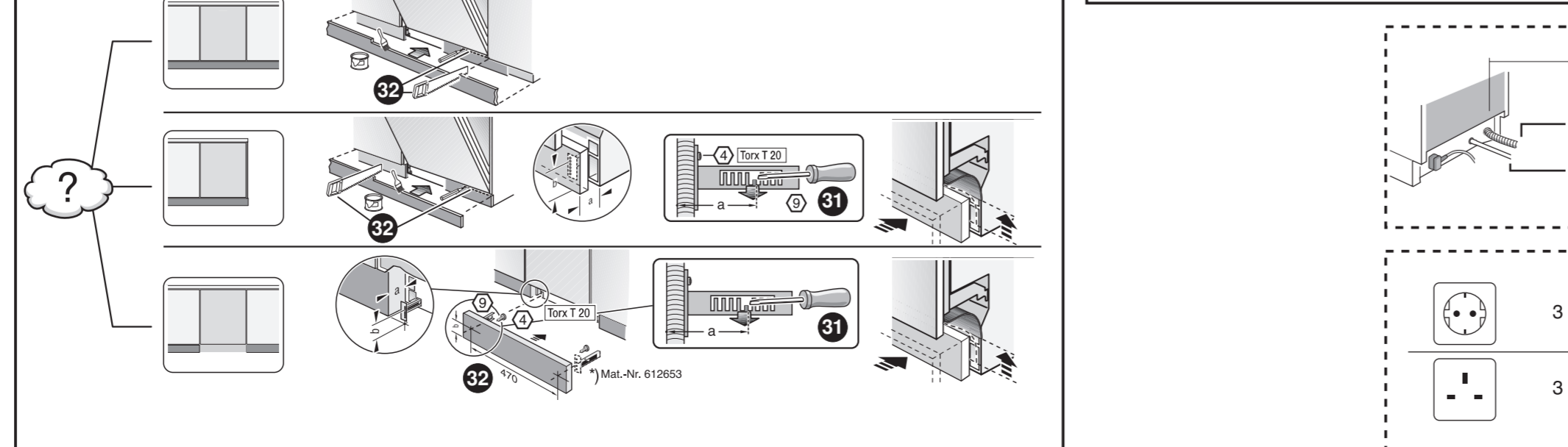
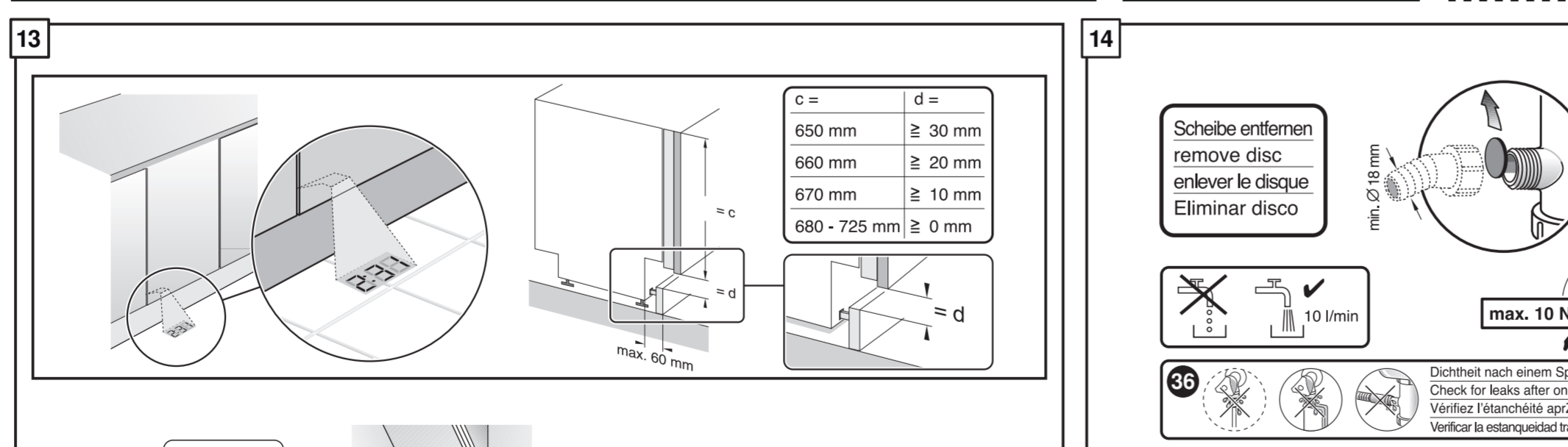
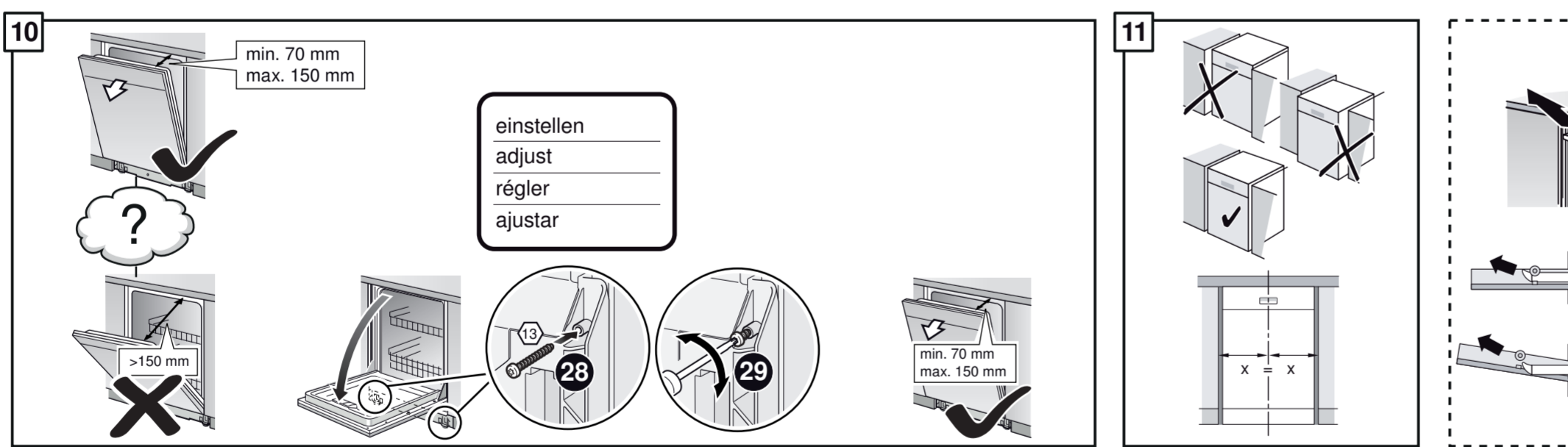
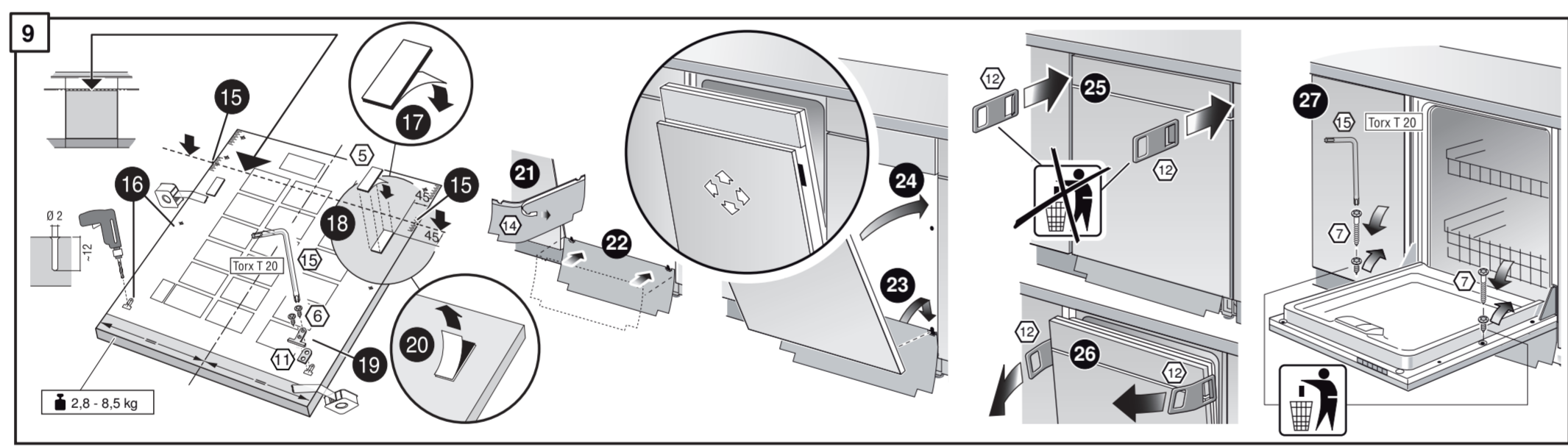
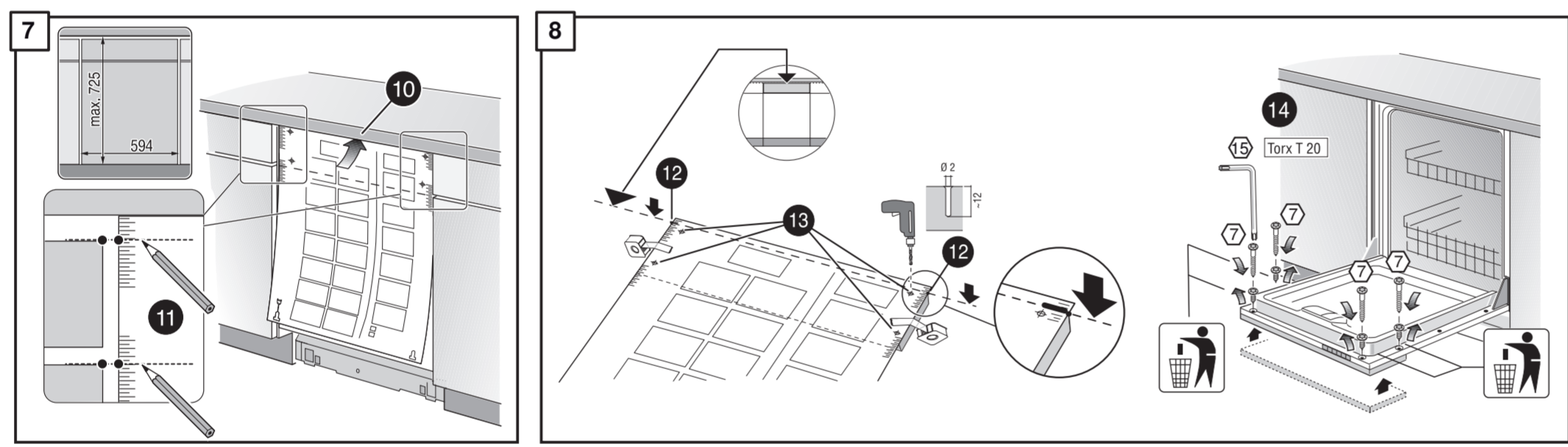
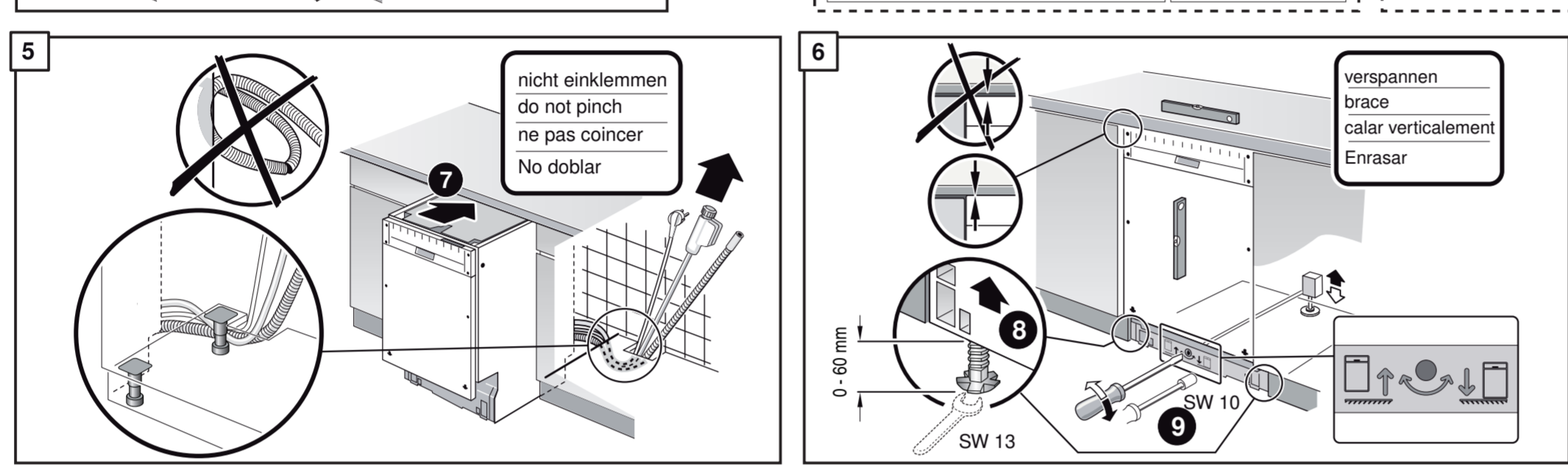
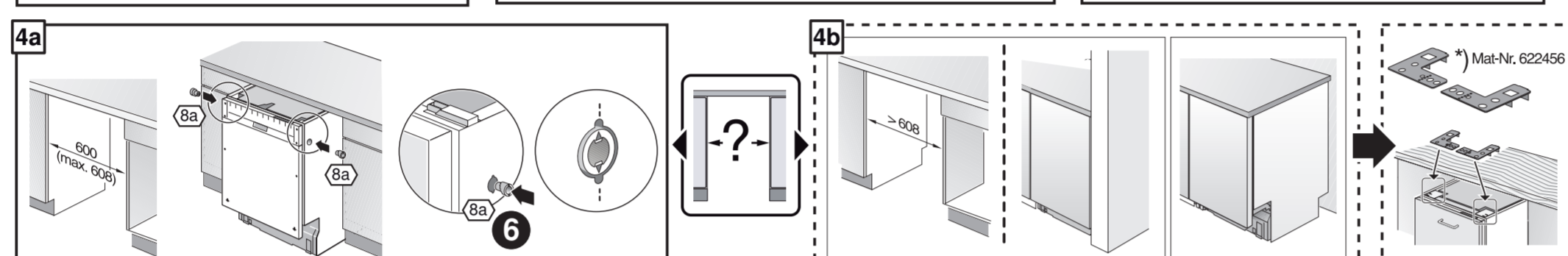
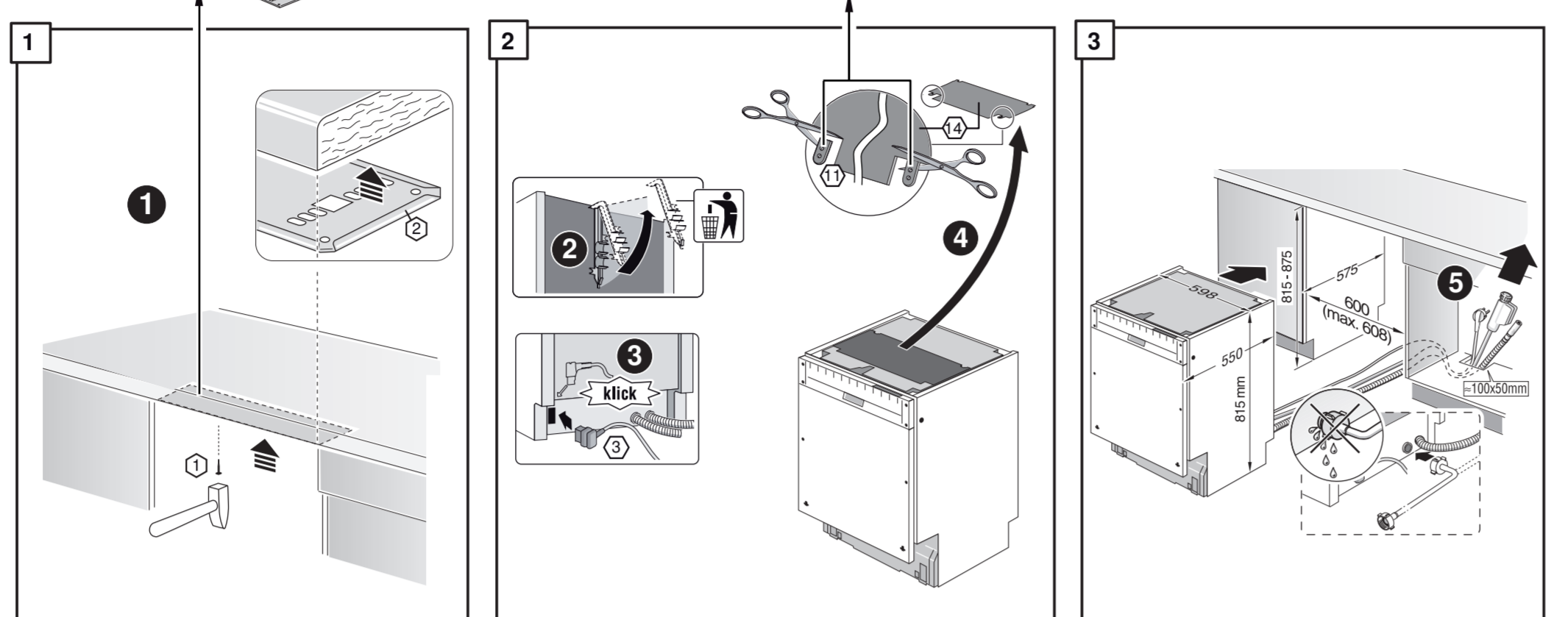
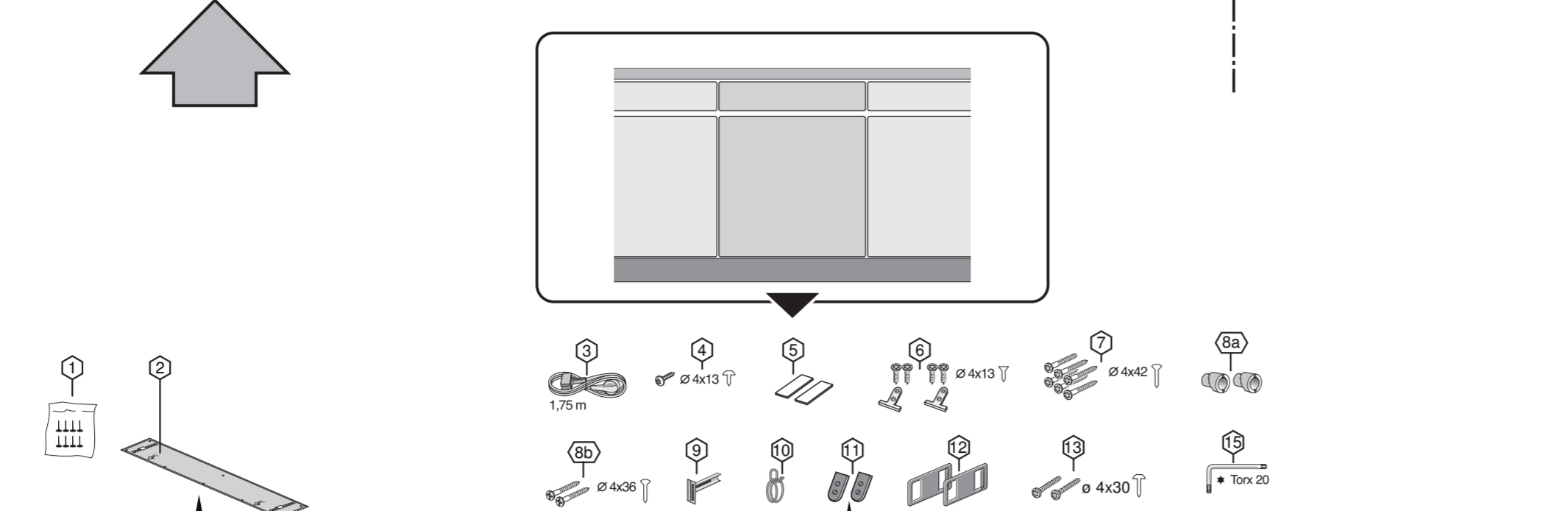
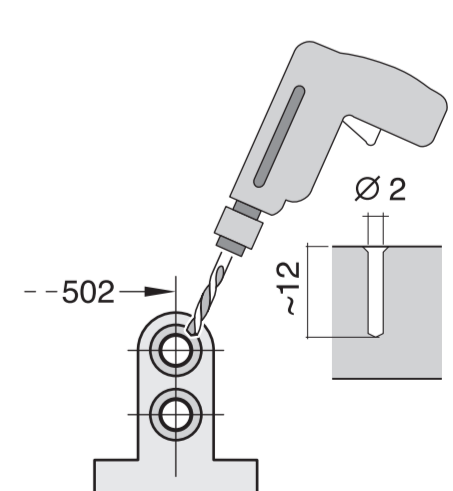
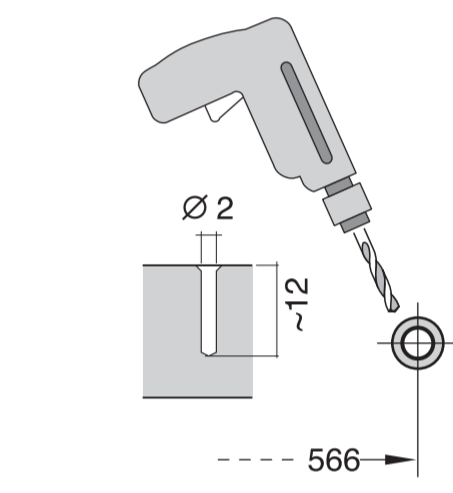
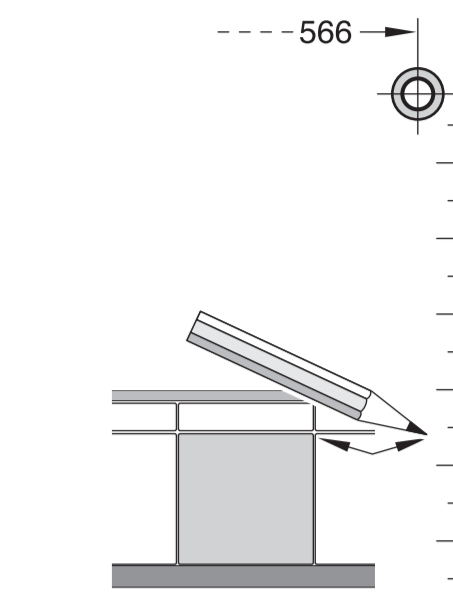
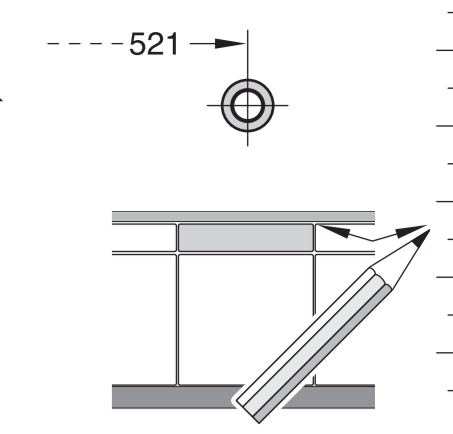
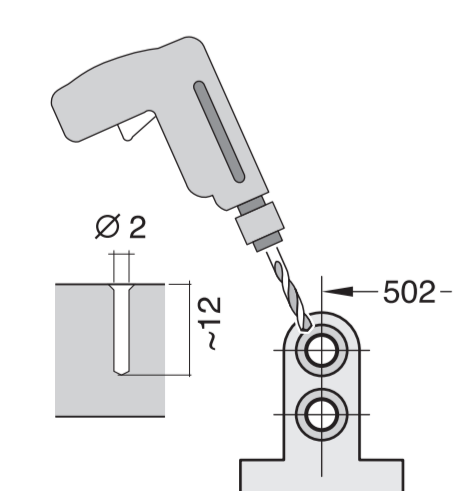
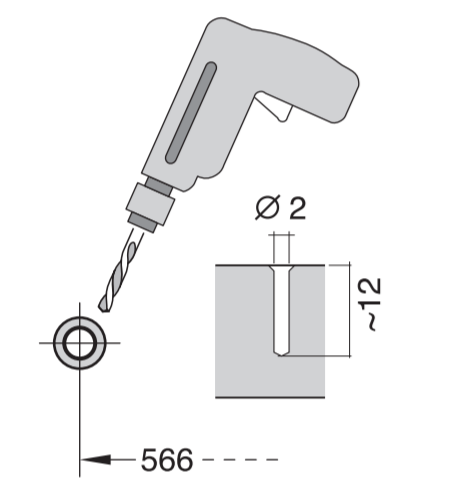
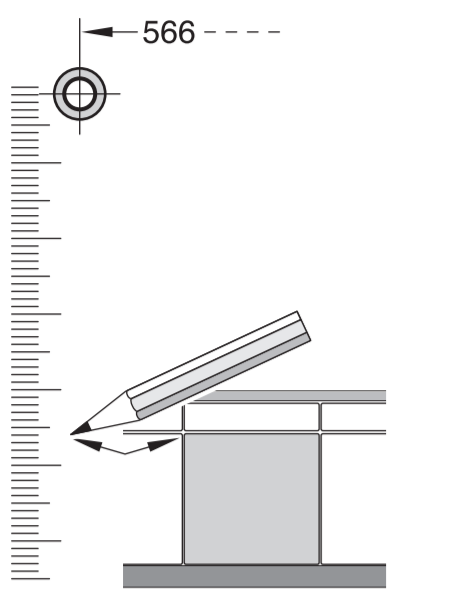
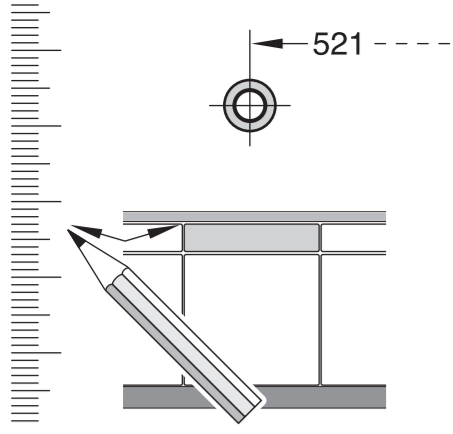

nicht einklemmen
do not pinch
ne pas coincer
No doblar

verspannen
brace
calar verticalment
Enrasar

min. 70 mm
max. 150 mm

einstellen
adjust
régler
ajustar

>150 mm

min. 70 mm
max. 150 mm

Scheibe entfernen
remove disc
enlever le disque
Eliminar disco

max. 10 Nm

Dichtheit nach einem Spülgang prüfen.
Check for leaks after one wash cycle.
Vérifiez l'étanchéité après un lavage.
Verificar la estanqueidad tras un ciclo de lavado

0.05 - 1 MPa
(0.5 - 10 bar)
max. 60°C

c =	d =
650 mm	≥ 30 mm
660 mm	≥ 20 mm
670 mm	≥ 10 mm
680 - 725 mm	≥ 0 mm

max. 60 mm

Mat.-Nr. 61953

Mat.-Nr. 61953

3 m	EU	*) Mat.-Nr. 644533
3 m	GB	*) Mat.-Nr. 644534

Mat.-Nr. 350564

Mat.-Nr. 657927