

GV 640 Voll-I - 81,5 cm - m. GS 9001 059 997 (9411)

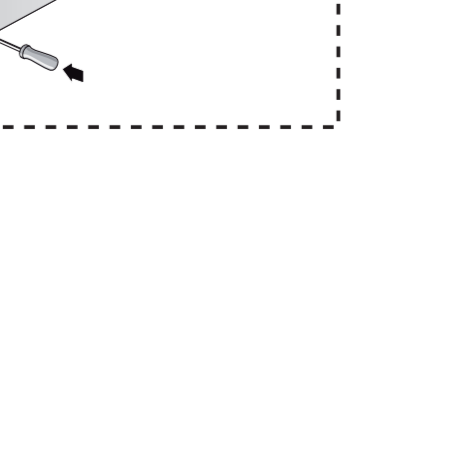

- de** Montageanleitung  
\*) über Kundendienst erhältlich
- en** Installation instructions  
\*) Available from customer service
- fr** Notice de montage  
\*) Disponible par le biais du service après-vente
- nl** Montagevoorschrift  
\*) Tegen meerprijs bij de Servicedienst verkrijgbaar
- it** Istruzioni per il montaggio  
\*) Disponibili presso il servizio assistenza clienti
- el** Οδηγίες τοποθέτησης  
\*) Διατίθεται από την υπηρεσία τεχνικής εξυπηρέτησης πελατών
- es** Instrucciones de montaje  
\*) Se puede adquirir a través del Servicio de Asistencia Técnica Oficial de la marca
- pt** Instruções de montagem  
\*) Pode ser adquirido nos nossos Serviços Técnicos
- sv** Monteringsanvisning  
\*) kan fås via Service
- tr** Montaj kılavuzu  
\*) Yetkili servis üzerinden alınabilir
- ru** Инструкция по монтажу  
\*) Можно получить в сервисном центре
- cs** Montážní návod  
\*) K dispozici přes servisní službu
- no** Monteringsanvisning  
\*) fåes hos kundeservice
- fi** Asennusohje  
\*) Saatavissa huoltoasemasta
- da** Monteringsvejledning  
\*) Kan købes hos serviceafdelingen
- pl** Instrukcja montażu  
\*) Do uzyskania w punkcie serwisowym
- hu** Szerelési utasítás  
\*) A vévőszolgálaton keresztül kapható:
- lv** Uputa za montažu  
\*) Uputa za montažu
- mk** Упатство за монтажа  
\*) Се добива преку службата за купувачи
- sl** Navodilo za montažo  
\*) Lahko nabavite v servisni službi
- sr** Uputstvo za montažu  
\*) Može se nabaviti preko servisne službe
- et** Monteerimisjuhend  
\*) küsige klienditeenindusest
- lt** Montavimo instrukcija  
\*) Iš galima gauti klientų aptarnavimo servise
- lv** Montāžas pamācība  
\*) Var saņemt servisa dienestā
- sk** Návod na montáž  
\*) Dostanete v službe zákazníkom
- hr** Udhuzues për montim  
\*) Sigurohet nëpërmjet servisit
- bs** Uputa za montažu  
\*) Može se dobiti preko servisne službe
- fa** راهنمای مونتاژ  
\*) از مرکز خدمات پس از فروش تهیه فرمایید
- ar** تعليمات التركيب  
\*) يمكن طلبها من مركز خدمة العملاء
- ko** 설치 설명서  
\*) 고객센터 센터에서 구입 가능
- zh** 安装说明书  
\*) 可向售后服务站索取。
- uk** Інструкція з монтажу  
\*) Можна отримати через сервісну службу
- id** Instruksi pemasangan  
\*) bisa didapatkan melalui Customer Service
- kk** Іске қосу туралы нұсқаулар!  
\*) Сервис қызмет көрсету орталығында алуға жатады

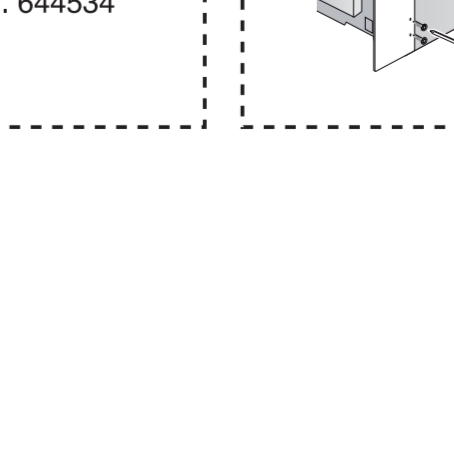

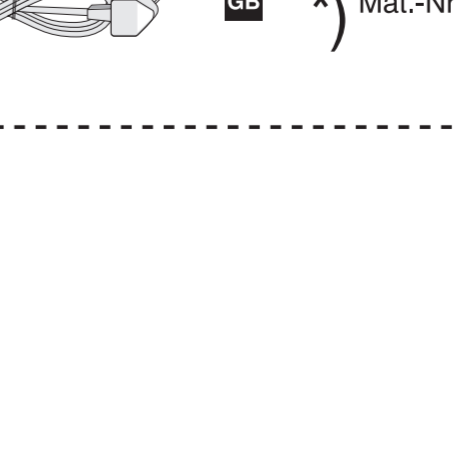
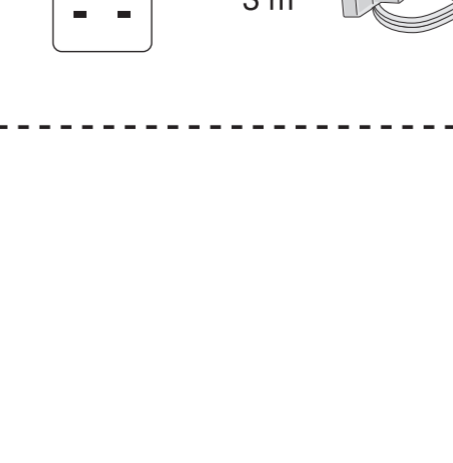
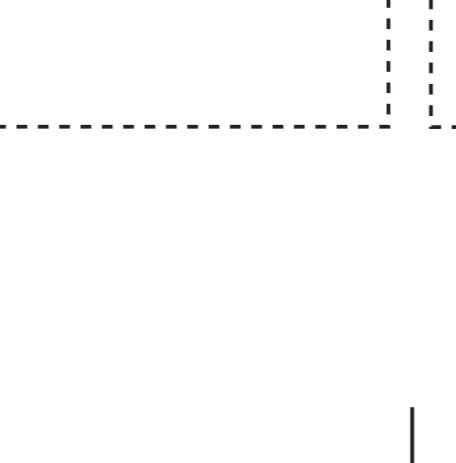
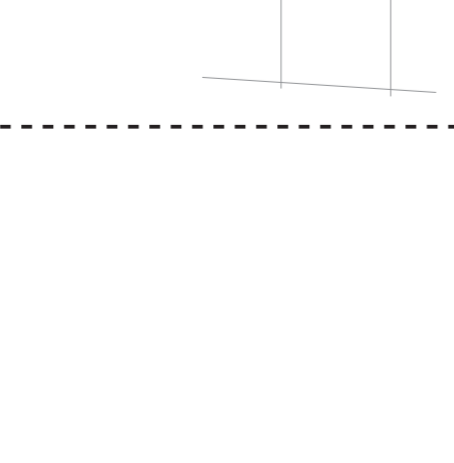
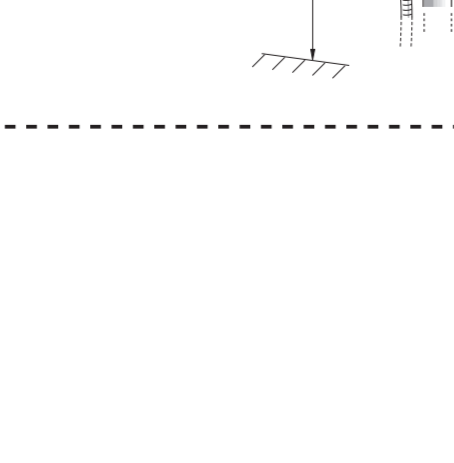
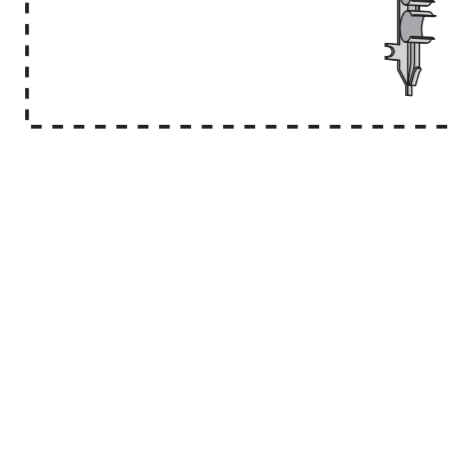
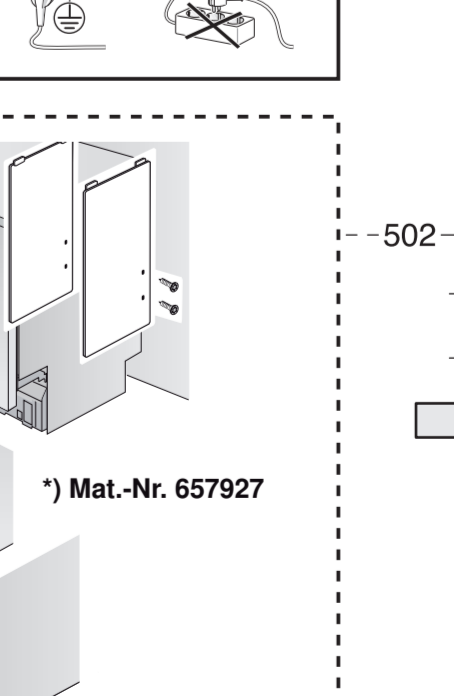
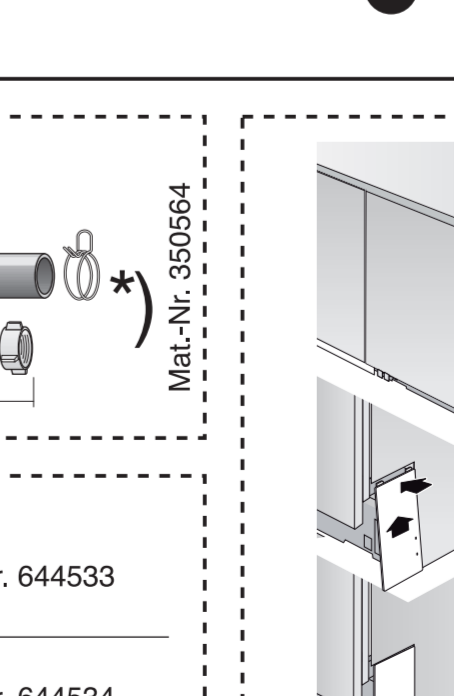
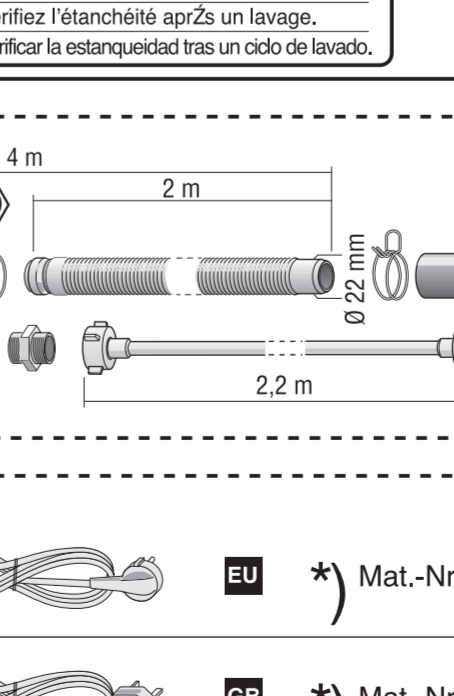
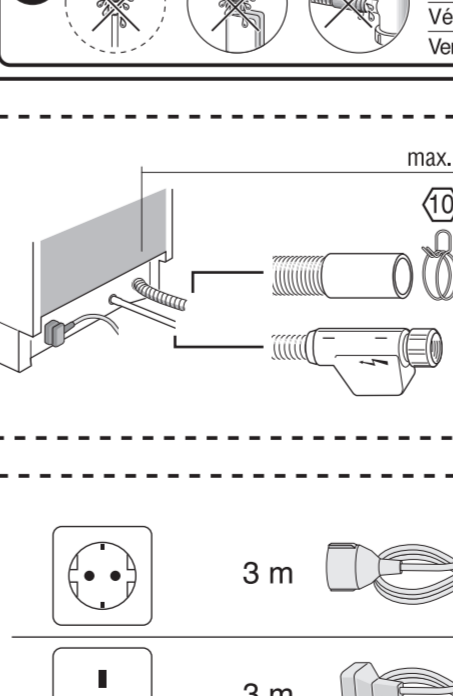
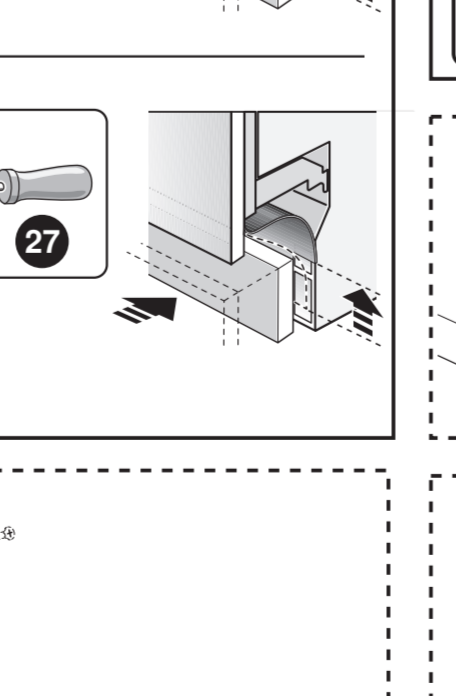
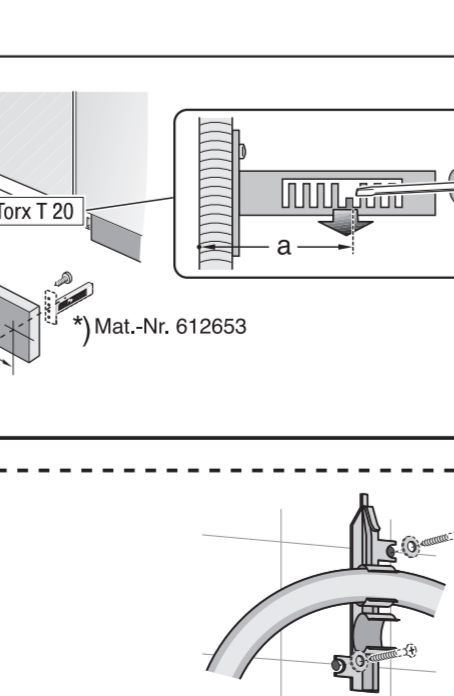
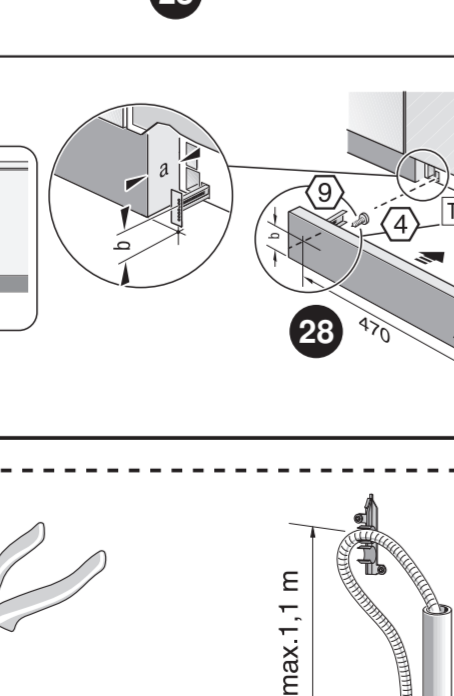
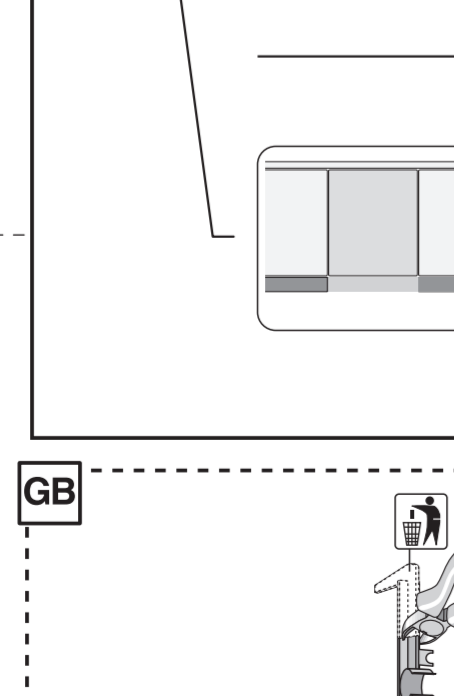
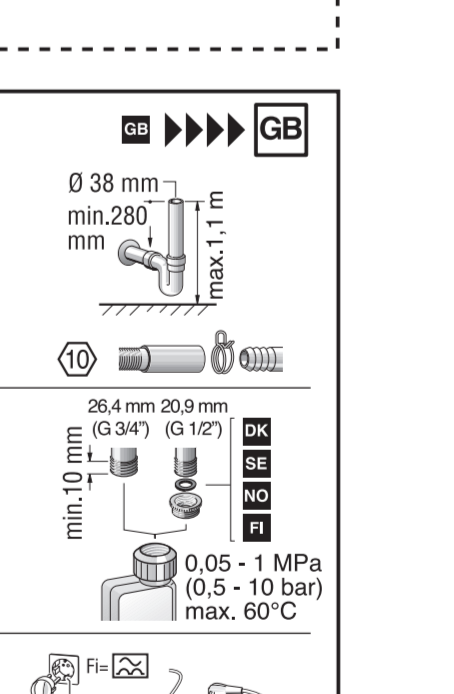
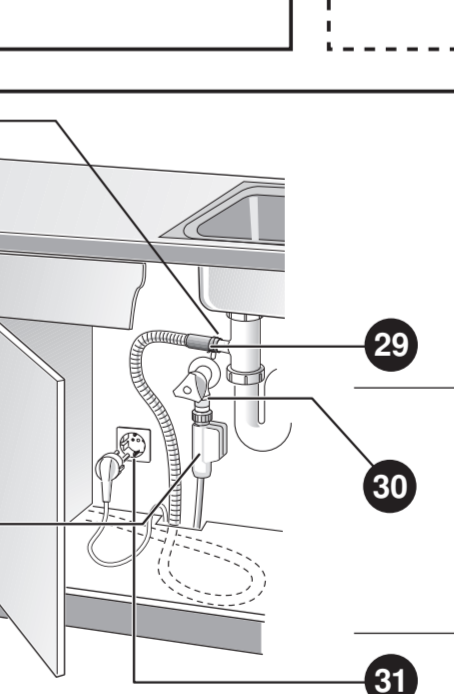
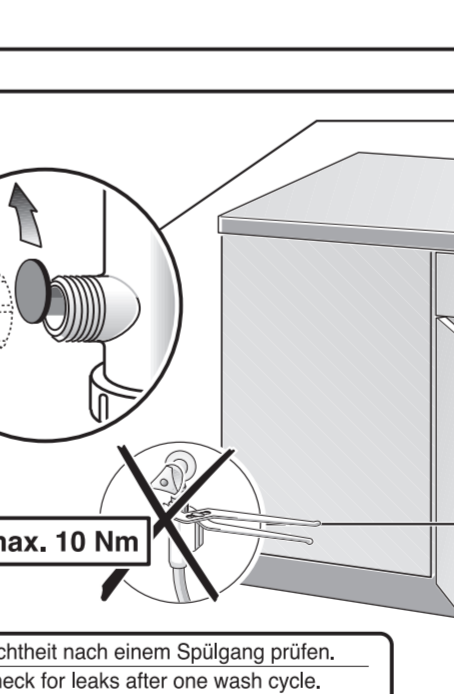
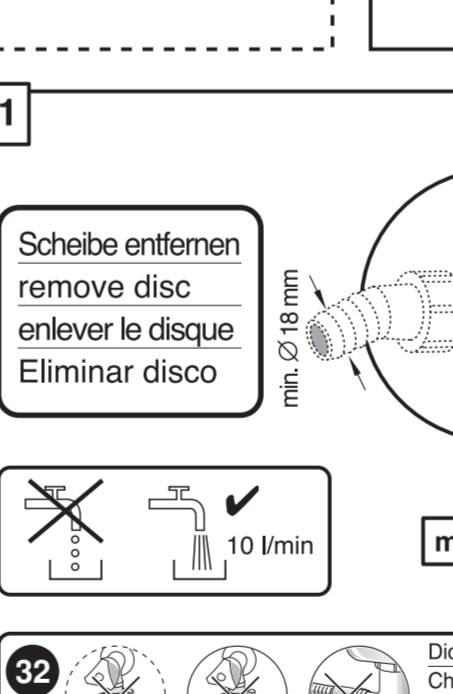
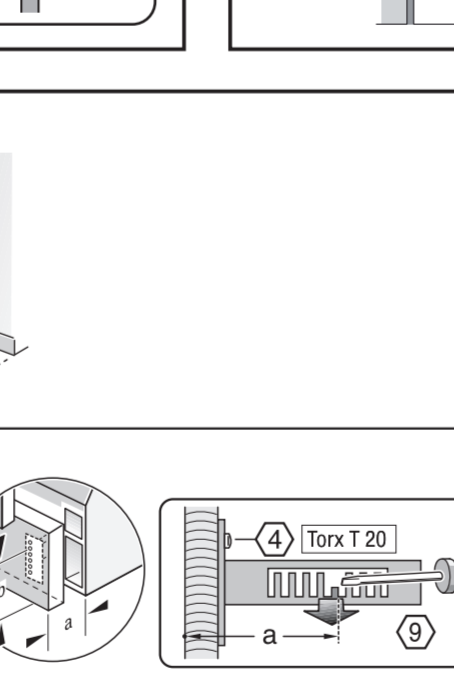
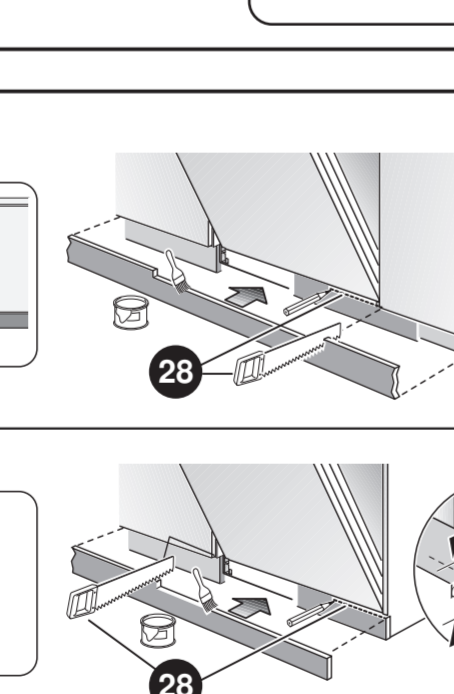
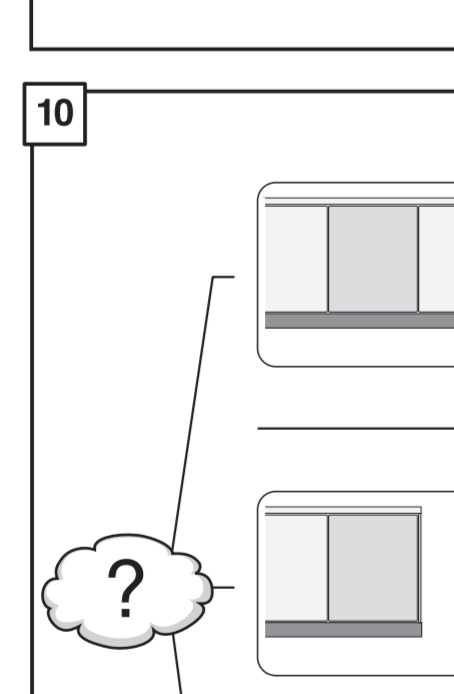
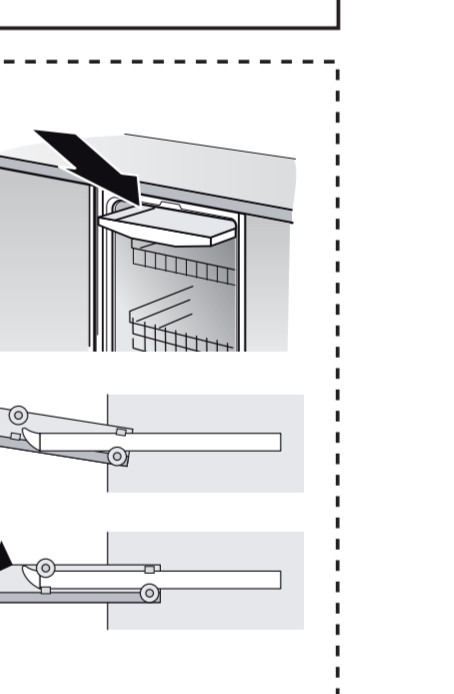
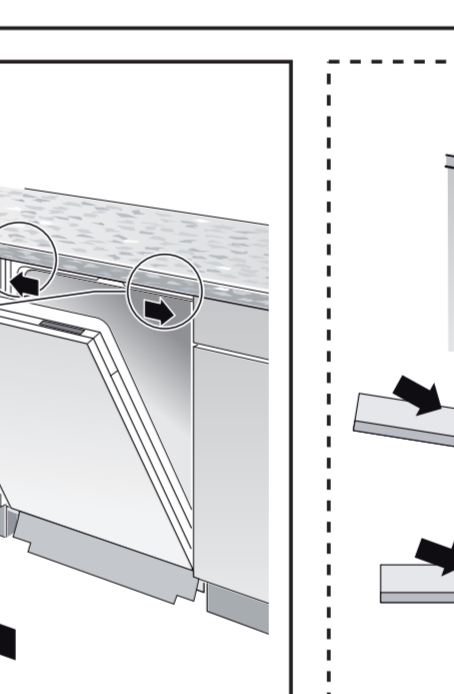
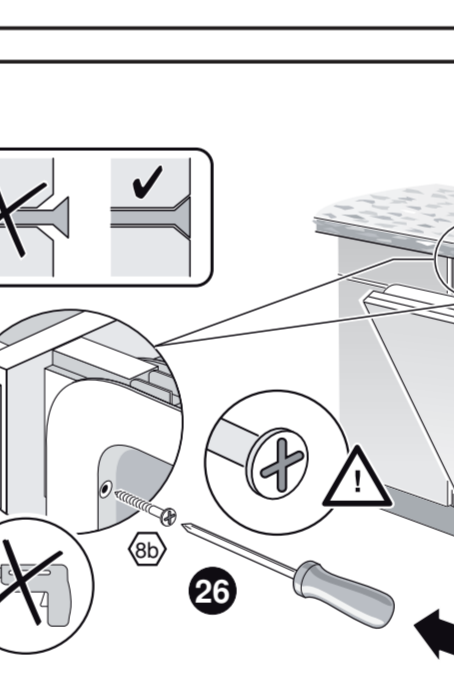
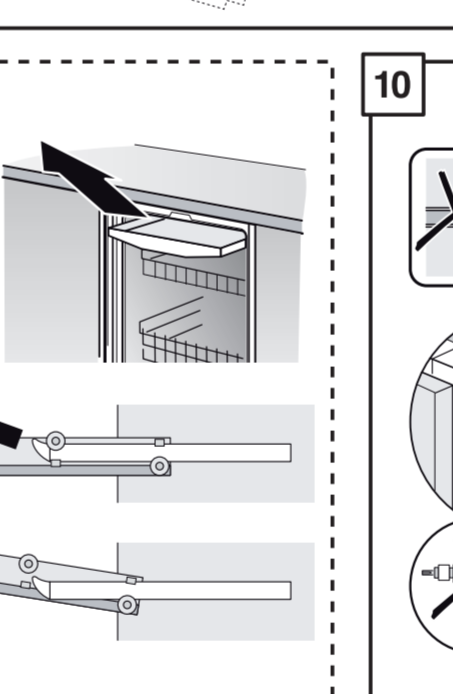
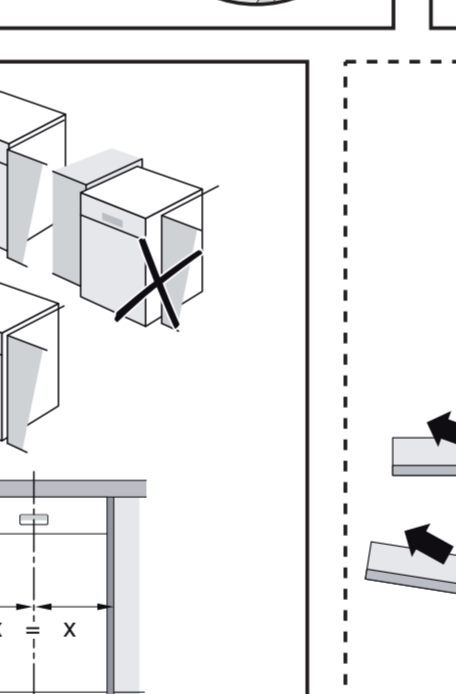
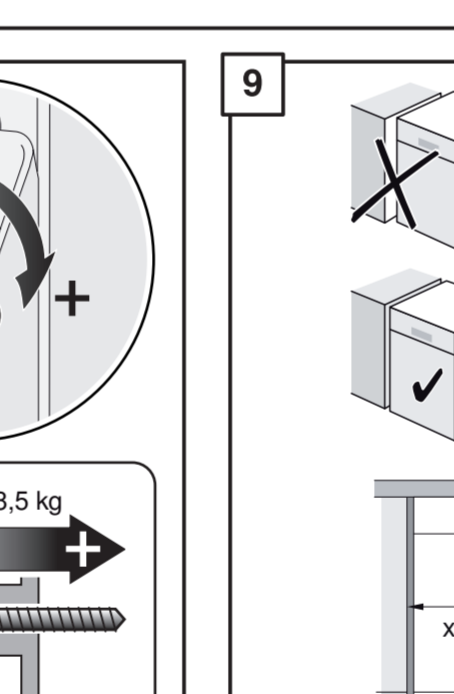
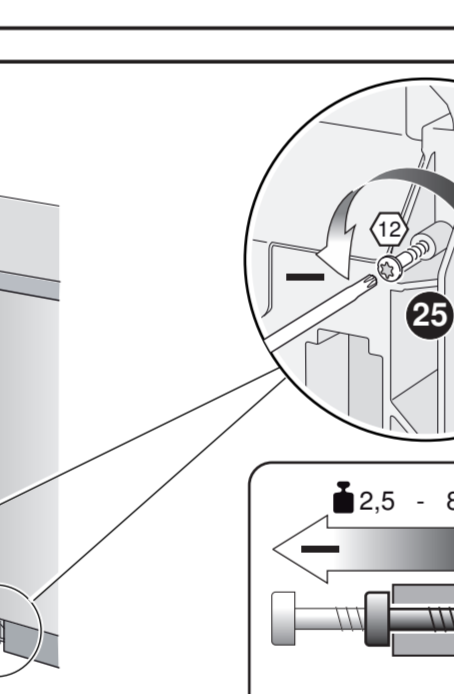
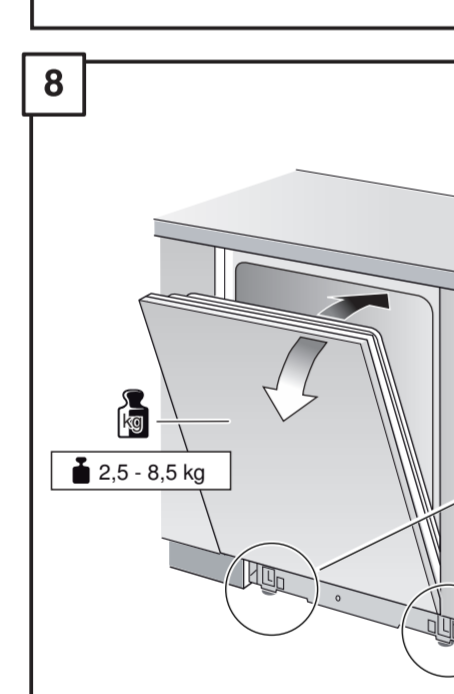
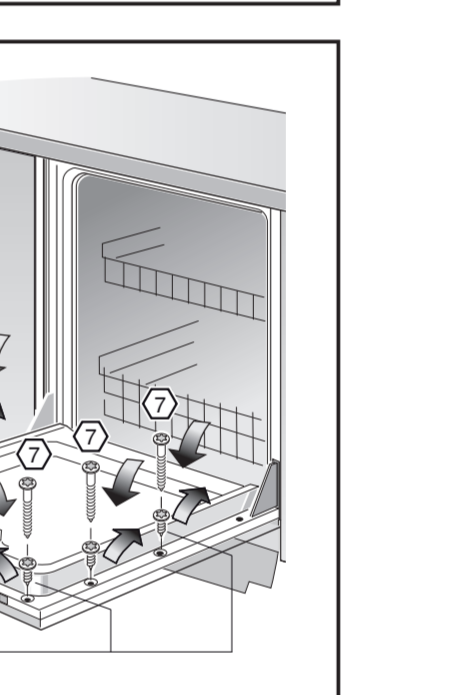
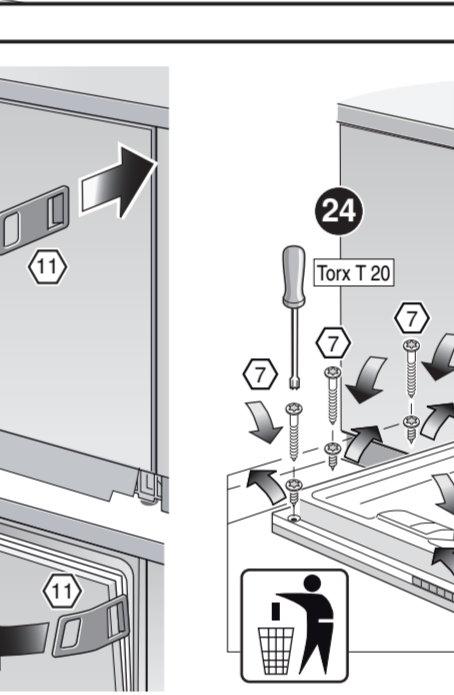
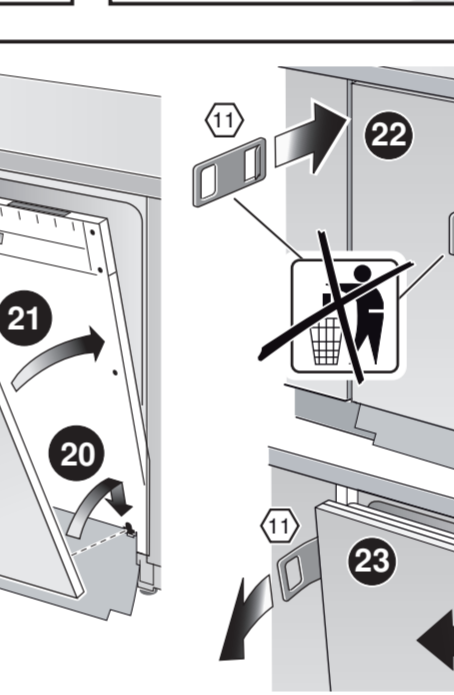
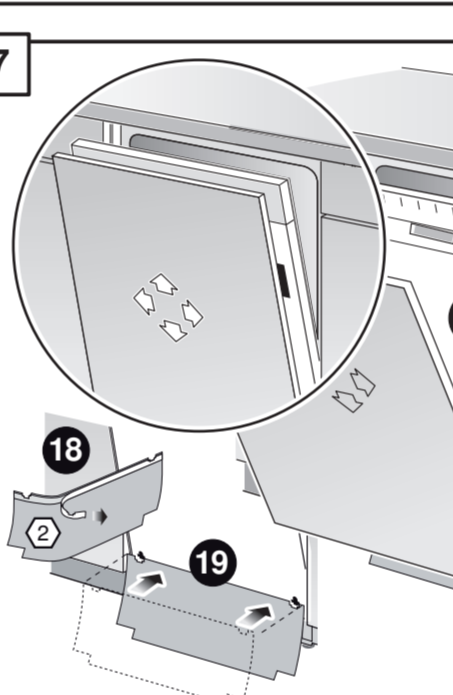
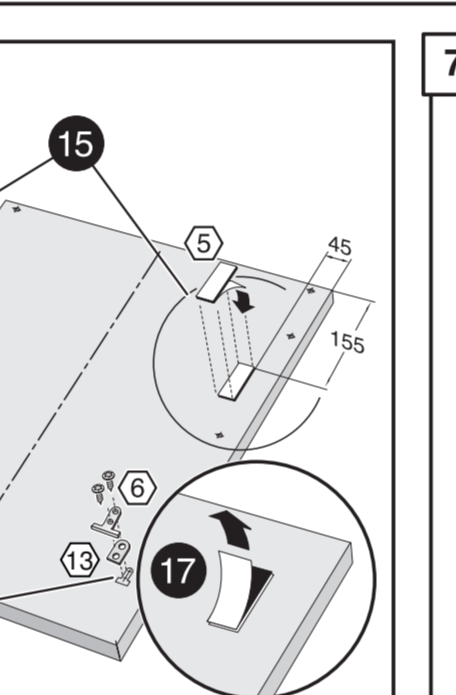
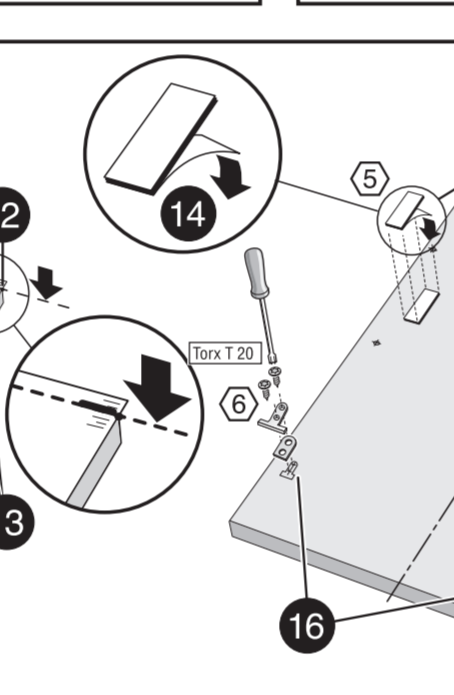
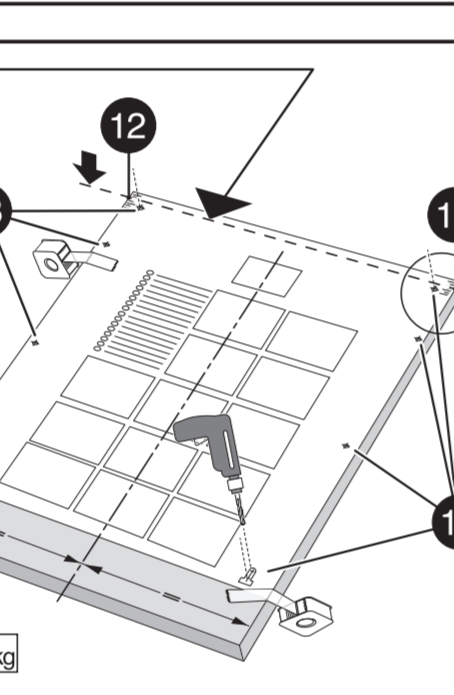
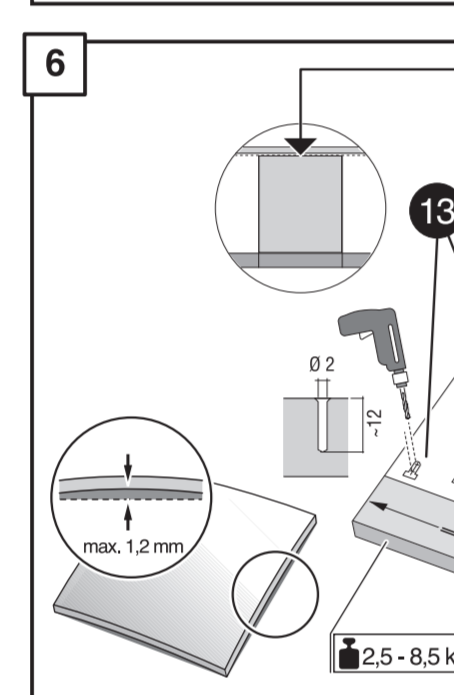
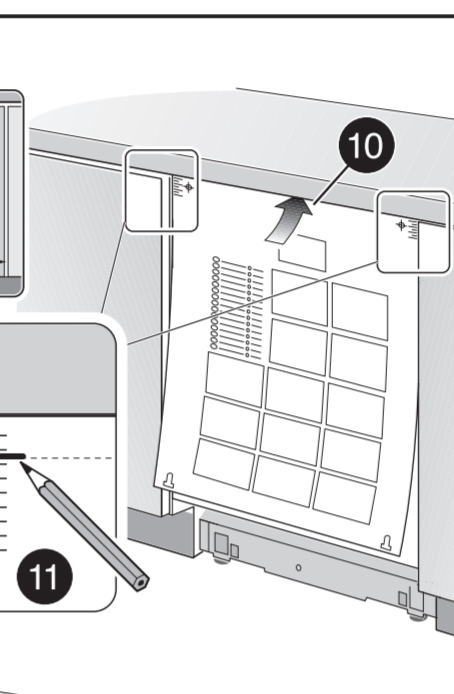
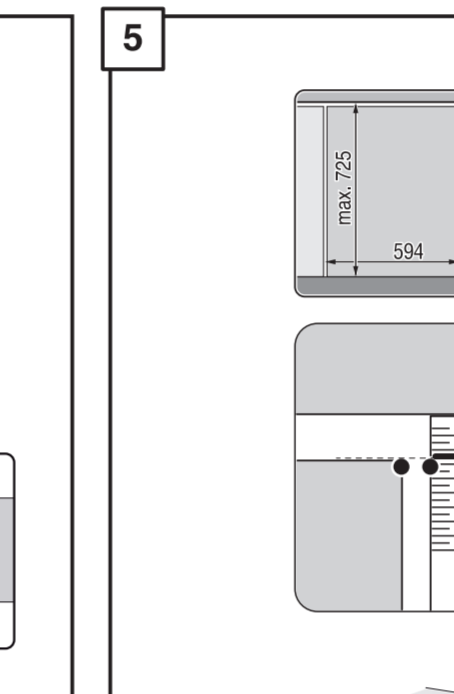
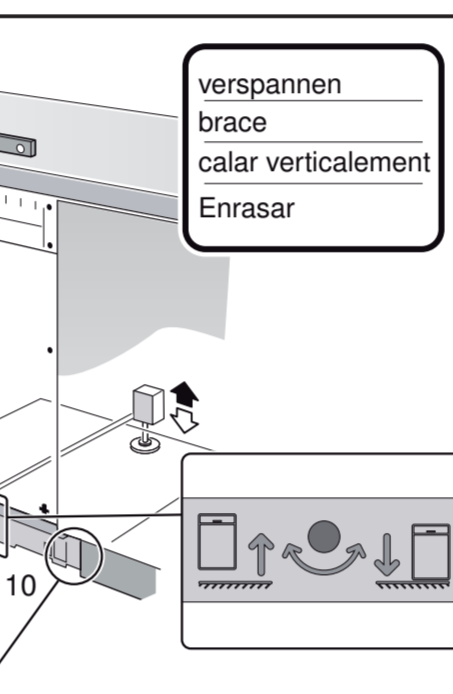
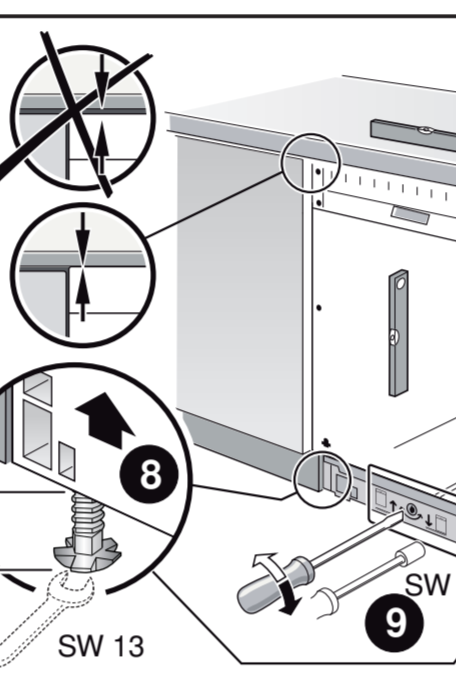
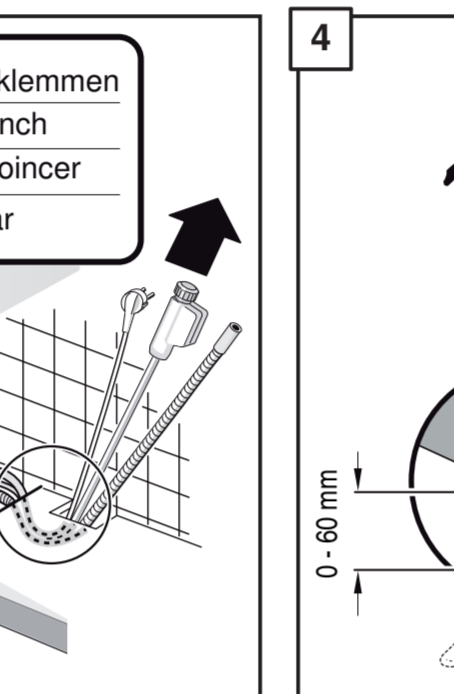
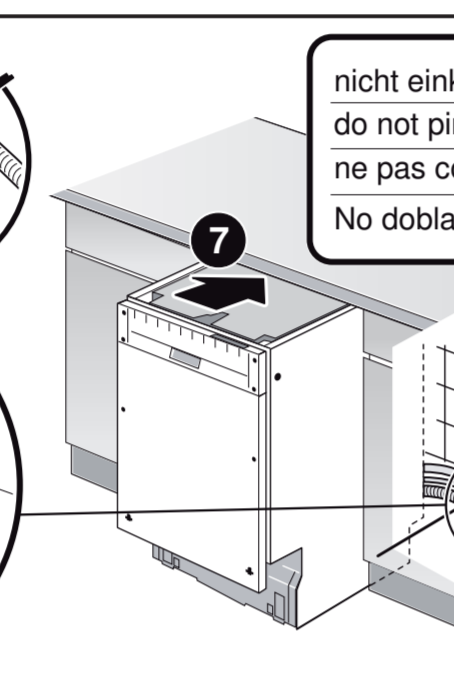
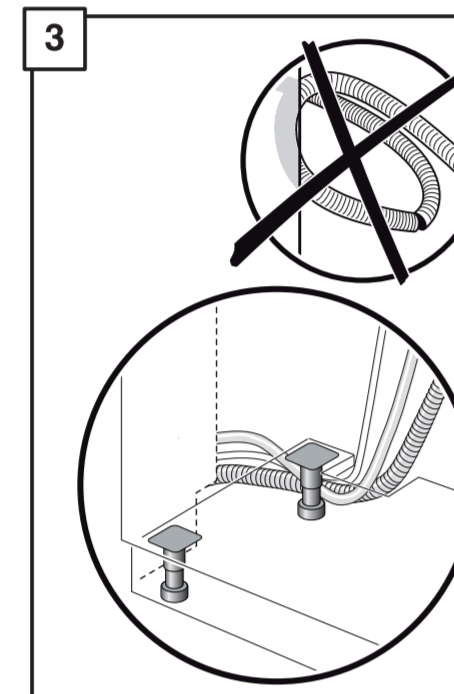
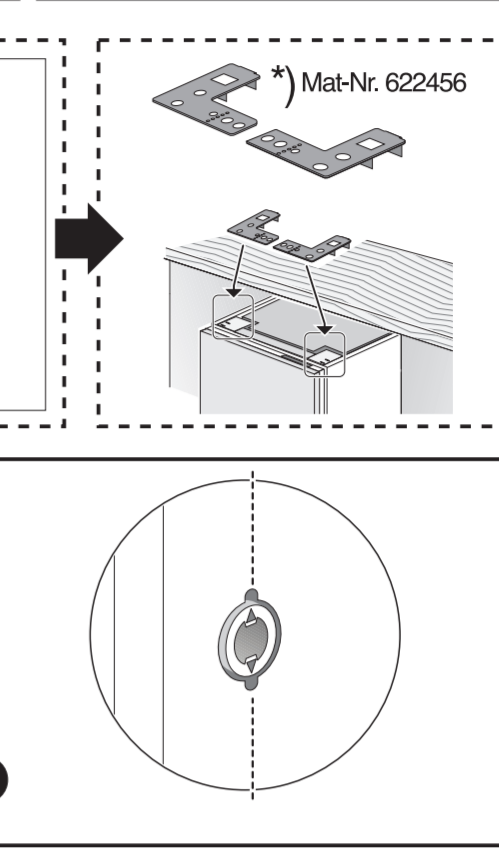
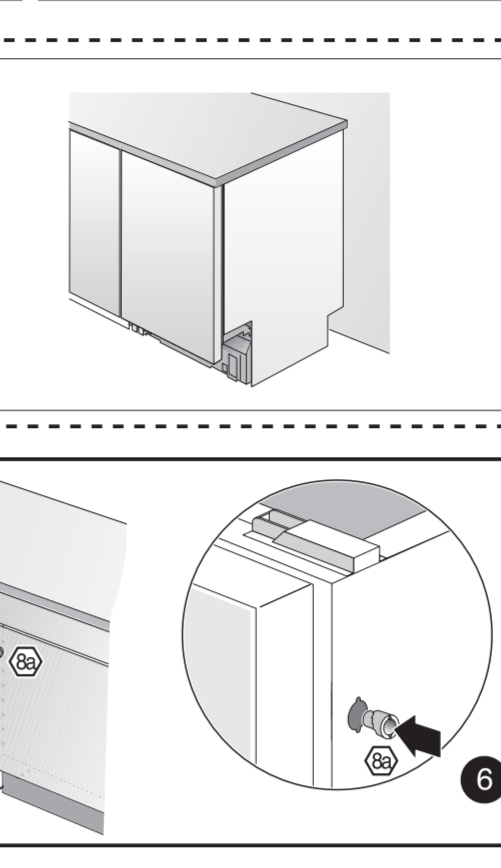
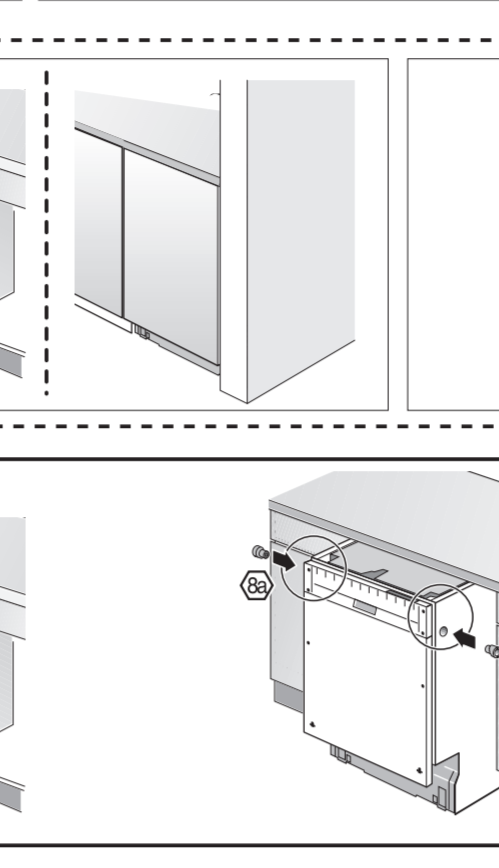
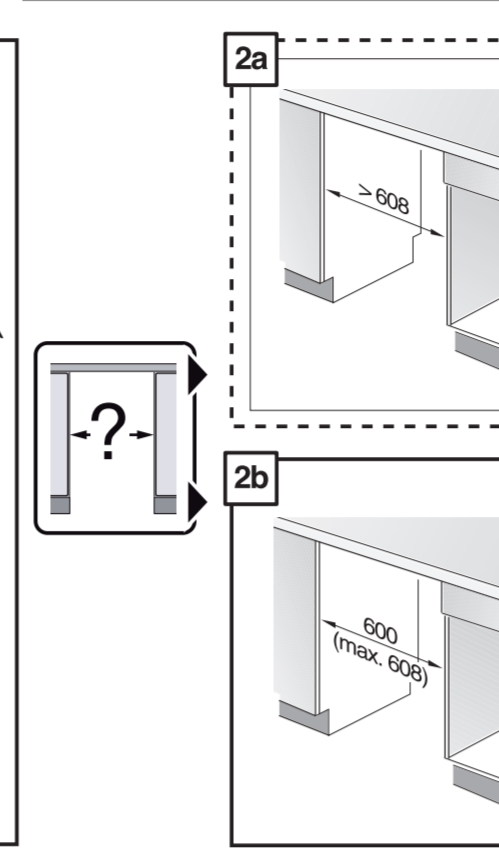
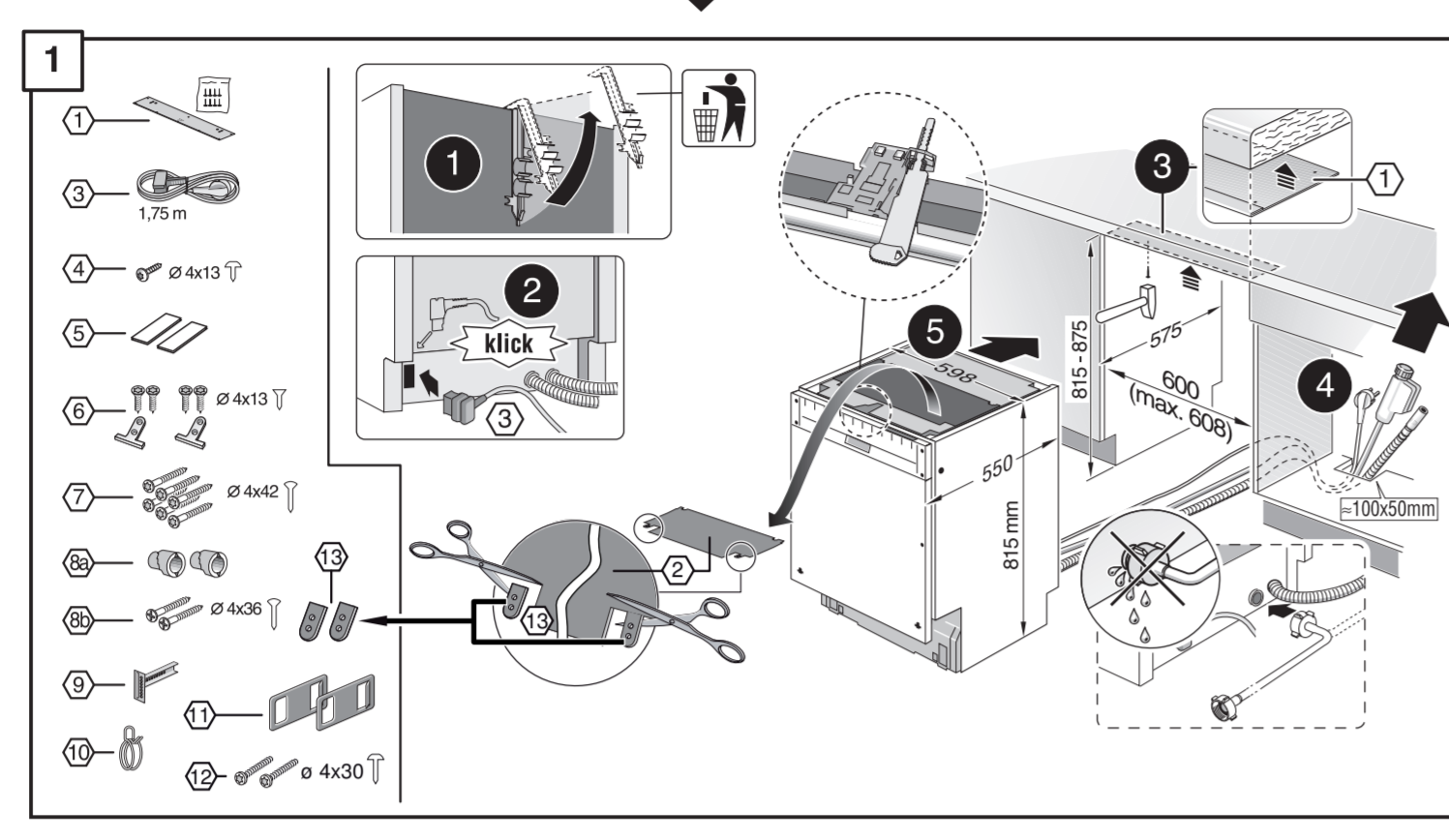
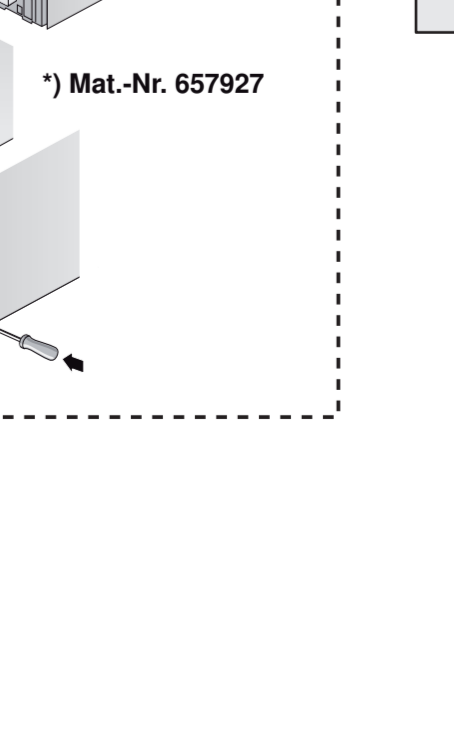
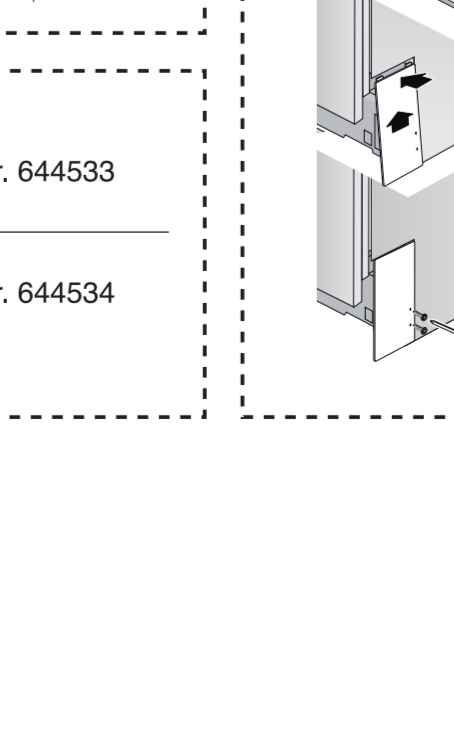
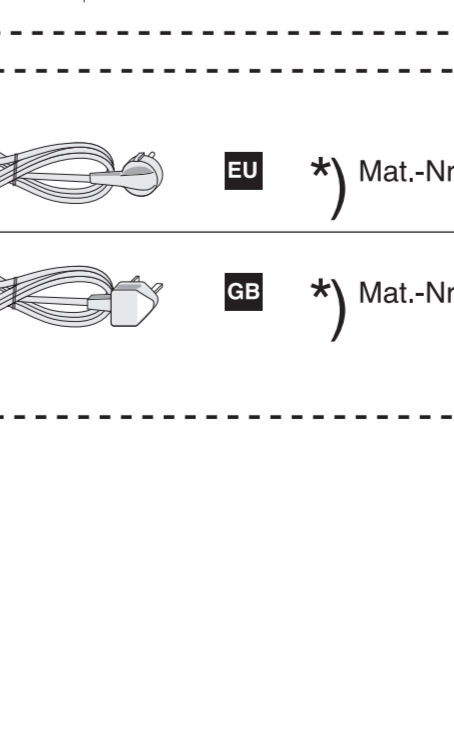
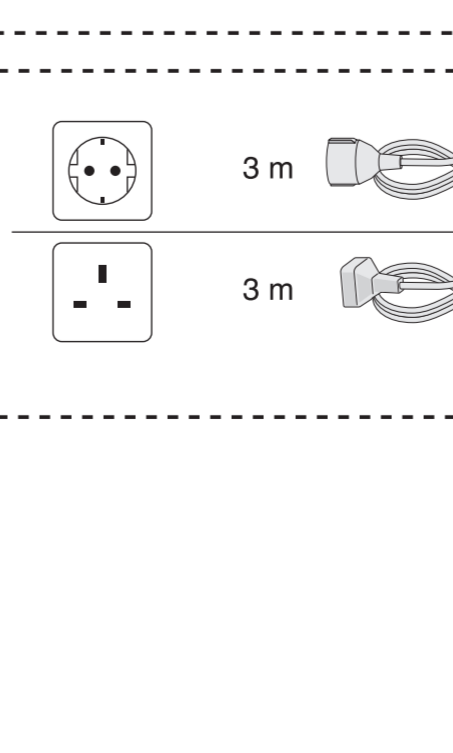
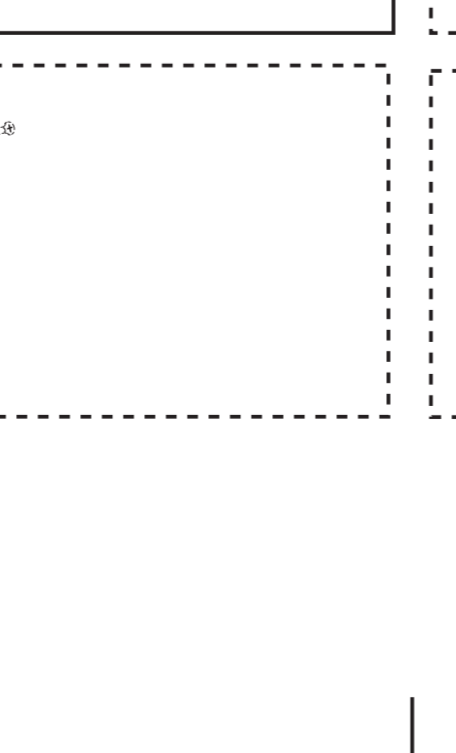
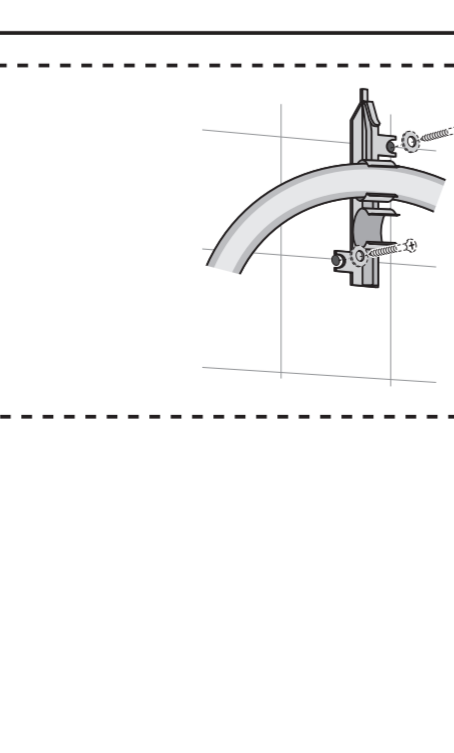
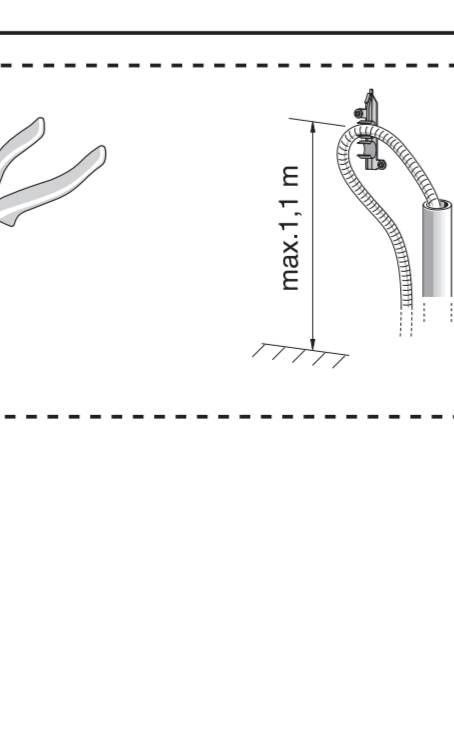
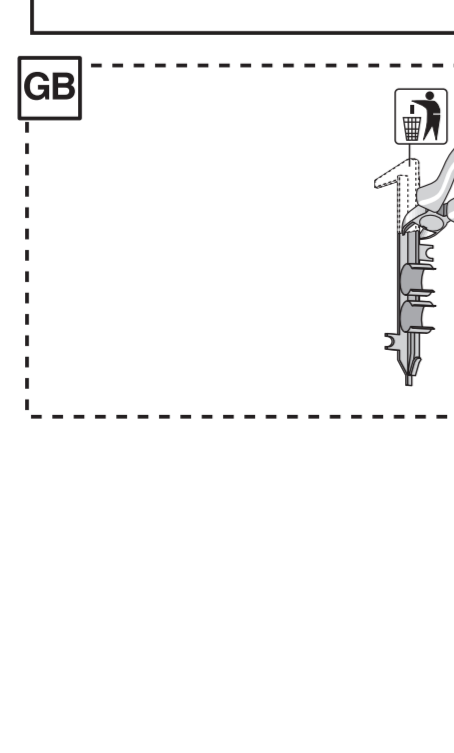
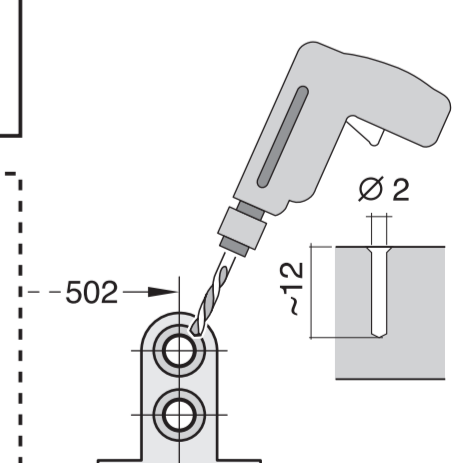
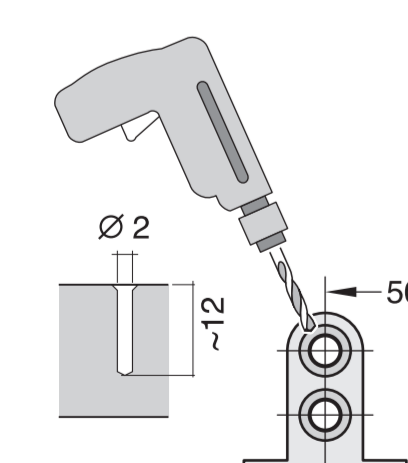
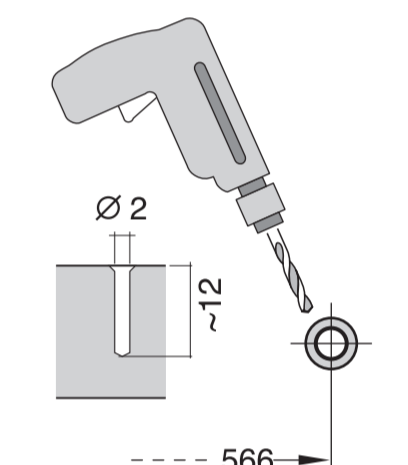
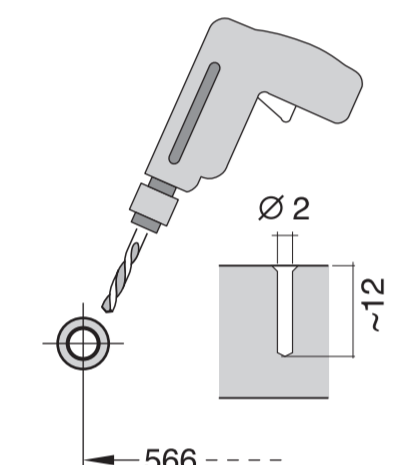
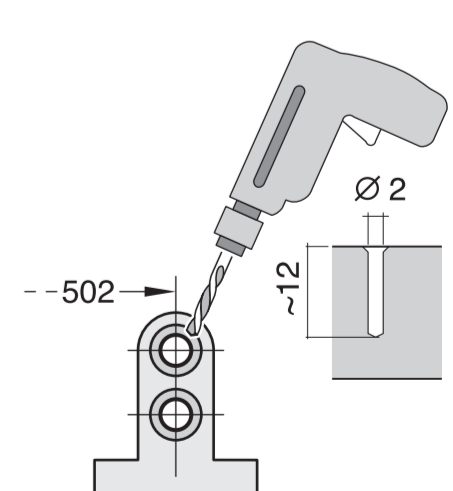
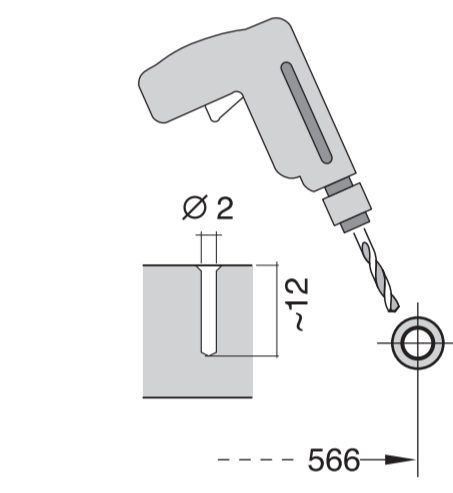
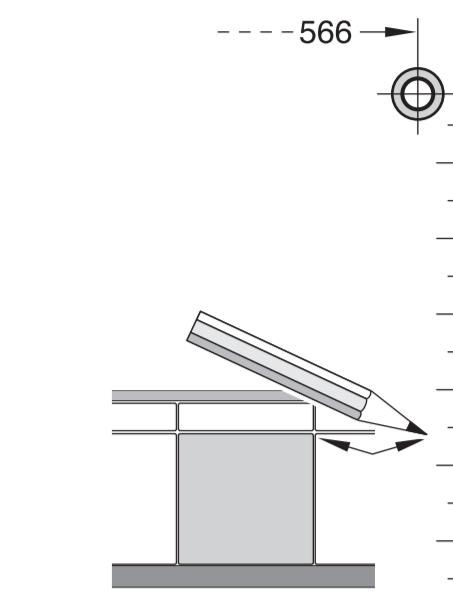
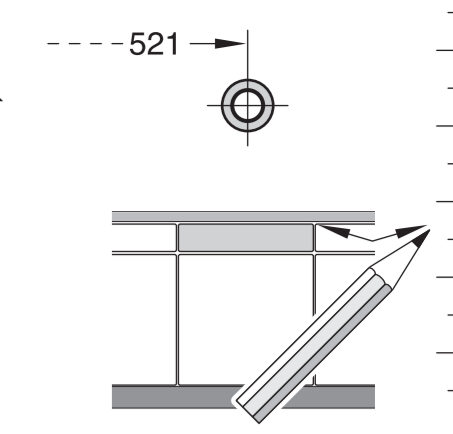
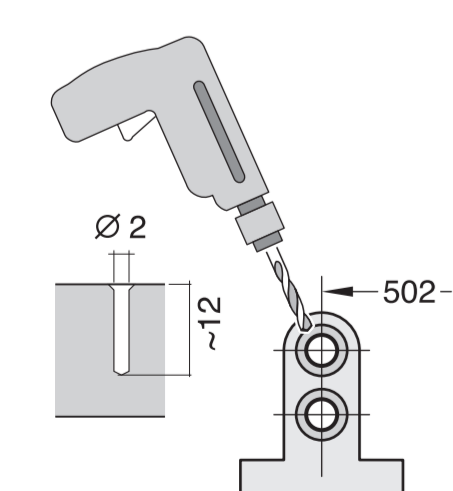
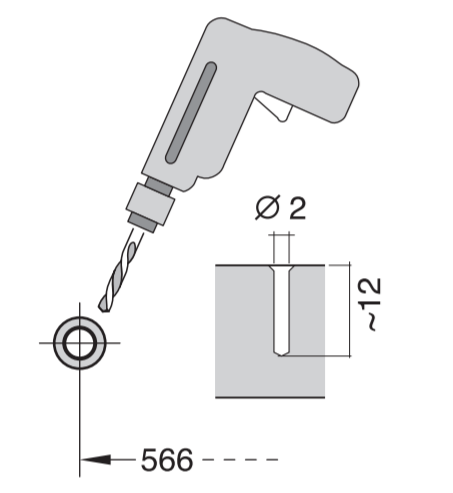
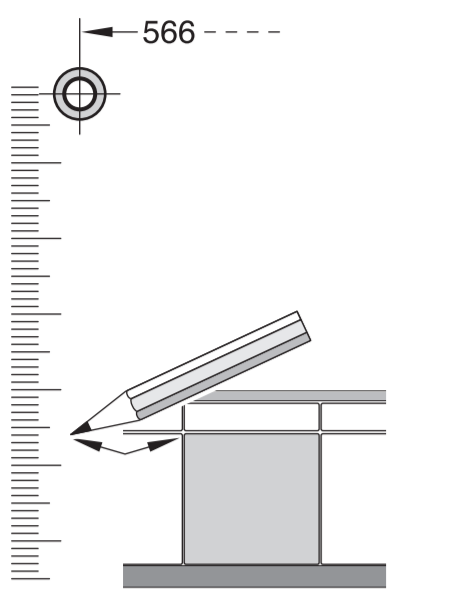
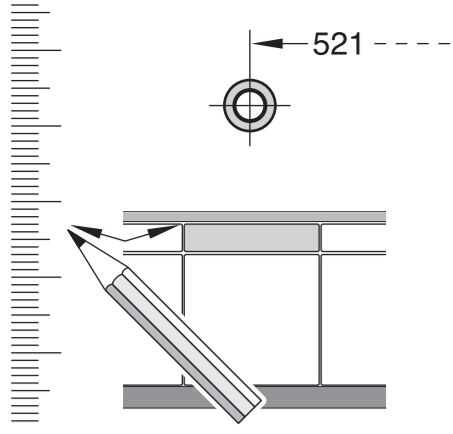

**1**

1  
2  
3  
4  
5  
6  
7  
8  
9  
10  
11  
12  
13  
14  
15  
16  
17  
18  
19  
20  
21  
22  
23  
24  
25  
26  
27  
28  
29  
30  
31  
32  
33  
34  
35

**2a**

**2b**

Mat-Nr. 622456

**3**

nicht einklemmen  
do not pinch  
ne pas coincer  
No doblar

**4**

verspannen  
brace  
calar verticalment  
Enrasar

0 - 60 mm  
SW 13

**5**

**6**

**7**

**1**

**4**

**5A**

**6A**

**7A**

**8**

**9**

**10**

**10**

**10**

**10**

**11**

Scheibe entfernen  
remove disc  
enlever le disque  
Eliminar disco

max. 10 Nm

Dichtheit nach einem Spülgang prüfen.  
Check for leaks after one wash cycle.  
Vérifier l'étanchéité après un lavage.  
Verificar la estanqueidad tras un ciclo de lavado.

Mat-Nr. 350564

Mat-Nr. 644533

Mat-Nr. 644534

Mat-Nr. 657927