

SIEMENS



Refrigerator

KI42F.. / KI27F..

siemens-home.bsh-group.com/welcome

en Instruction for Use

Register
your
product
online

en Table of Contents

Safety and warning information	3	Refrigerator compartment	10
Information concerning disposal	5	The “cool-fresh” compartment	10
Scope of delivery	6	Interior fittings	12
Ambient temperature and ventilation	6	Switching off and disconnecting the appliance	12
Installation location	7	Defrosting	12
Connecting the appliance	7	Cleaning the appliance	13
Getting to know your appliance	8	Odours	14
Switching on the appliance	8	Light (LED)	14
Setting the temperature	9	Tips for saving energy	14
Super cooling	9	Operating noises	15
Alarm function	9	Eliminating minor faults yourself	15
Usable capacity	10	Customer service	17

Safety and warning information

Before you switch ON the appliance

Please read the operating and installation instructions carefully! They contain important information on how to install, use and maintain the appliance. The manufacturer is not liable if you fail to comply with the instructions and warnings. Retain all documents for subsequent use or for the next owner.

Technical safety

The appliance contains a small quantity of environmentally friendly but flammable refrigerant R600a. Ensure that the tubing of the refrigerant circuit is not damaged during transportation and installation. Leaking refrigerant may cause eye injuries or ignite.

If damage has occurred

- Keep naked flames and/or ignition sources away from the appliance,
- thoroughly ventilate the room for several minutes,

- switch off the appliance and pull out the mains plug,
- inform customer service.

The more refrigerant an appliance contains, the larger the room must be in which the appliance is situated. Leaking refrigerant can form a flammable gas-air mixture in rooms which are too small. The room must be at least 1 m³ per 8 g of refrigerant. The amount of refrigerant in your appliance is indicated on the rating plate inside the appliance.

If the power cord of this appliance is damaged, it must be replaced by the manufacturer, customer service or a similarly qualified person. Improper installations and repairs may put the user at considerable risk.

Repairs may be performed by the manufacturer, customer service or a similarly qualified person only.

Only original parts supplied by the manufacturer may be used. The manufacturer guarantees that only these parts satisfy the safety requirements.

An extension cable may be purchased from customer service only.

Important information when using the appliance

- Never use electrical appliances inside the appliance (e.g. heater, electric ice maker, etc.). Explosion hazard!
 - Never defrost or clean the appliance with a steam cleaner! The steam may penetrate electrical parts and cause a short-circuit. Risk of electric shock!
 - Do not use pointed or sharp-edged implements to remove frost or layers of ice. You could damage the refrigerant tubes. Leaking refrigerant may cause eye injuries or ignite.
 - Do not store products which contain flammable propellants (e.g. spray cans) or explosive substances in the appliance. Explosion hazard!
 - Do not stand on or lean heavily against base of appliance, drawers or doors, etc
 - For defrosting and cleaning, pull the mains plug out or switch off the fuse. Do not pull out the mains plug by tugging on the power cord.
 - Store high-percentage alcohol tightly closed and standing up.
- Keep plastic parts and the door seal free of oil and grease. Otherwise, parts and door seal will become porous.
 - Never cover or block the ventilation openings of the appliance!
 - **Avoiding placing children and vulnerable people at risk:**

At risk are children, people who have limited physical, mental or sensory abilities, as well as people who have inadequate knowledge concerning safe operation of the appliance.

Ensure that children and vulnerable people have understood the hazards.

A person responsible for safety must supervise or instruct children and vulnerable people who are using the appliance.

Only children from 8 years and above may use the appliance.

Supervise children who are cleaning and maintaining the appliance.

Never allow children to play with the appliance.

Children in the household

- Keep children away from packaging and its parts. Danger of suffocation from folding cartons and plastic film!
- Do not allow children to play with the appliance!
- If the appliance features a lock: keep the key out of the reach of children!

General regulations

The appliance is suitable for refrigerating food.

This appliance is intended for use in the home and the home environment.

The appliance is suppressed according to EU Directive 2004/108/EC.

The refrigeration circuit has been checked for leaks.

This product complies with the relevant safety regulations for electrical appliances (EN 60335-2-24).

This appliance is intended for use up to a maximum height of 2000 metres above sea level.

Information concerning disposal

Disposal of packaging

The packaging protects your appliance from damage during transit. All utilised materials are environmentally safe and recyclable. Please help us by disposing of the packaging in an environmentally friendly manner.

Please ask your dealer or inquire at your local authority about current means of disposal.

Disposal of your old appliance

Old appliances are not worthless rubbish! Valuable raw materials can be reclaimed by recycling old appliances.



This appliance is labelled in accordance with European Directive 2012/19/EU concerning used electrical and electronic appliances (waste electrical and electronic equipment - WEEE). The guideline determines the framework for the return and recycling of used appliances as applicable throughout the EU.

Warning

Redundant appliances

1. Pull out the mains plug.
2. Cut off the power cord and discard with the mains plug.
3. Do not take out the trays and receptacles: children are therefore prevented from climbing in!
4. Do not allow children to play with the appliance once it has spent its useful life. Danger of suffocation!

Refrigerators contain refrigerant and gases in the insulation. Refrigerant and gases must be disposed of professionally. Ensure that tubing of the refrigerant circuit is not damaged prior to proper disposal.

Scope of delivery

After unpacking all parts, check for any damage in transit.

If you have any complaints, please contact the dealer from whom you purchased the appliance or our customer service.

The delivery consists of the following parts:

- Built-in appliance
- Interior fittings (depending on model)
- Bag containing installation materials
- Operating instructions
- Installation manual
- Customer service booklet
- Warranty enclosure
- Information on the energy consumption and noises

Ambient temperature and ventilation

Ambient temperature

The appliance is designed for a specific climate class. Depending on the climate class, the appliance can be operated at the following temperatures.

The climate class can be found on the rating plate. Fig. **13**

Climate class	Permitted ambient temperature
SN	+10 °C to 32 °C
N	+16 °C to 32 °C
ST	+16 °C to 38 °C
T	+16 °C to 43 °C

Note

The appliance is fully functional within the room temperature limits of the indicated climatic class. If an appliance of climatic class SN is operated at colder room temperatures, the appliance will not be damaged up to a temperature of +5 °C.

Ventilation

Fig. **1**/20

The refrigeration unit is ventilated only via the ventilation grille in the base. Never cover the ventilation grille or place anything in front of it. Otherwise the refrigeration unit must work harder, increasing the power consumption.

Installation location

Install the appliance in a dry, well ventilated room. The installation location should neither be exposed to direct sunlight nor near a heat source, e. g. a cooker, radiator, etc. If installation next to a heat source is unavoidable, use a suitable insulating plate or observe the following minimum distances to a heat source:

- 3 cm to electric or gas cookers.
- 30 cm to an oil or coal-fired cooker.

Connecting the appliance

After installing the appliance, wait at least 1 hour until the appliance is switched on. During transportation the oil in the compressor may have flowed into the refrigeration system.

Before switching on the appliance for the first time, clean the interior of the appliance (see chapter “Cleaning the appliance”).

Electrical connection

The socket must be near the appliance and also freely accessible following installation of the appliance.

The appliance complies with the protection class I. Connect the appliance to 220–240 V/50 Hz alternating current via a correctly installed socket with protective conductor. The socket must be fused with a 10 to 16 A fuse.

For appliances operated in non-European countries, check whether the stated voltage and current type match the values of your mains supply. This information can be found on the rating plate. Fig. **13**

Warning

Never connect the appliance to electronic energy saver plugs.

Our appliances can be used with mains and sine-controlled inverters. Mains-controlled inverters are used for photovoltaic systems which are connected directly to the national grid. Sine-controlled inverters must be used for isolated applications (e.g. on ships or in mountain lodges) which are not connected directly to the national grid.

Getting to know your appliance

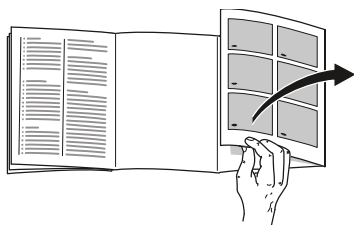

Please fold out the illustrated last page. These operating instructions refer to several models.

The features of the models may vary.

The diagrams may differ.

Fig. **1**

* Not all models.

- A Refrigerator compartment
- B Cool-fresh compartment

- 1-5 Controls
- 6 On/Off button
- 7 Light, refrigerator compartment
- 8 Glass shelf "EasyLift"
- 9 Fixed glass shelf
- 10 Delicatessen container
- 11* Butter and cheese compartment
- 12* Egg rack
- 13 Door shelf "EasyLift"
- 14* Bottle holder
- 15 Shelf for large bottles
- 16 Light, cool-fresh compartment
- 17 "Cool-fresh" container
- 18 Humidity filter
- 19 Humidity container
- 20 Ventilation opening

Controls

Fig. **2**

- 1 **Alarm button**
Used to switch off the warning signal, see chapter "Alarm function".
- 2 **"Super" button refrigerator compartment**
Switches super cooling on and off.
- 3 **Refrigerator compartment temperature selection button**
The button sets the temperature in the refrigerator compartment.
- 4 **Temperature display refrigerator compartment**
The numbers correspond to the set refrigerator compartment temperatures in °C.
- 5 **ON/OFF display**
The ON/OFF display is lit when the appliance is in operation.

Switching on the appliance

Switch on the appliance with the On/Off button, Fig. **1**/6.

The temperature display for the refrigerator compartment, Fig. **2**/4, flashes until the appliance has reached the set temperature.

The appliance begins to cool. Light is switched on when the door is open.

We recommend a factory setting of +4 °C in the refrigerator compartment.

Do not store perishable food warmer than +4 °C.

Operating tips

- After the appliance has been switched on, it may take several hours until the set temperature has been reached.
Do not put any food in the appliance beforehand.
- The front sides of the housing are partly heated slightly. This prevents condensation in the area of the door seal.

Setting the temperature

Fig. 2

Refrigerator compartment

The temperature can be set from +2 °C to +8 °C.

Keep pressing temperature setting button on refrigerator compartment 3, until the required refrigerator compartment temperature is set.

The value last selected is saved. The set temperature is indicated on the temperature display for the refrigerator compartment 4.

Cool-fresh compartment

The temperature in the “cool-fresh” compartment has been set to almost 0 °C at the factory and should not be changed if at all possible.

If frost forms on the refrigerated food, the temperature can be increased. (See chapter “Eliminating minor faults yourself”.)

Super cooling

Super cooling sets the refrigerator temperature to the coldest temperature setting for approx. 6 hours. Then the appliance automatically switches to the temperature set prior to super cooling mode.

Switch on super cooling mode, e.g.

- before placing large quantities of food in the refrigerator compartment.
- for the fast cooling of drinks.

Switching on and off

Fig. 2

Press super button 2 refrigerator compartment.

The button is lit when super cooling is switched on.

Note

When super cooling is switched on, increased operating noises may occur.

Alarm function

Door alarm

The door alarm (continuous sound) switches on if the appliance door is open for longer than two minutes. Close the door to switch off the warning signal.

Switching off the alarm

Fig. 2

Press the alarm button 1 to switch off the warning signal.

Usable capacity

Information on the usable capacity can be found inside your appliance on the rating plate. Fig. 13

Refrigerator compartment

The refrigerator compartment is the ideal storage location for ready meals, cakes and pastries, preserved food, condensed milk and hard cheese.

Storing food

- Store fresh, undamaged food. The quality and freshness will then be retained for longer.
- In the case of ready-made products and bottled goods, observe the best-before date or use-by date specified by the manufacturer.
- To retain aroma, colour and freshness, pack or cover food well before placing in the appliance. This will prevent the transfer of flavours and the discolouration of plastic parts in the refrigerator compartment.
- Allow warm food and drinks to cool down before placing in the appliance.

Note

Avoid contact between food and rear panel. Otherwise the air circulation will be impaired.

Food or packaging could freeze to the rear panel.

Note the chill zones in the refrigerator compartment

The air circulation in the refrigerator compartment creates different chill zones:

- The coldest zones are on the rear panel and in the delicatessen containers. Fig. 3
- Warmest zone is at the very top of the door.

Note

Store e.g. hard cheese and butter in the warmest zone. Cheese can then continue to release its flavour and the butter will still be easy to spread.

The “cool-fresh” compartment

The temperature in the fridge is about 0 °C. The low temperature and the optimum moisture provide ideal storage conditions for fresh food.

Food can be kept fresh up to three times longer in the “cool-fresh” compartment than in the normal cooling zone – for even longer freshness, nutrient retention and flavour.

“Cool-fresh” container

Fig. 1/17

The storage climate in the “cool-fresh” container offers ideal conditions for the storage of fish, meat, sausage, cheese and milk.

Humidity container

Fig. 1/19

The humidity container is covered with a special filter which optimises retention of the air humidity in the storage compartment. As a result, there is up to 95 % air humidity in the humidity container, depending on the amount of products put in. This storage climate offers ideal conditions for fresh fruit, salad greens, vegetables, herbs or mushrooms.

Notes

- Fruit sensitive to cold (e.g. pineapple, banana, papaya and citrus fruit) and vegetables sensitive to cold (e.g. aubergines, cucumbers, zucchini, peppers, tomatoes and potatoes) should be stored outside the refrigerator at temperatures of approx. +8 °C to +12 °C for optimum preservation of quality and flavour.
- Condensation may form in the humidity container depending on the type and quantity of products stored. Remove condensation with a dry cloth.

Foods suitable for “cool-fresh” container:

In the “cool-fresh” container:

Fig. 1/17

- Fish, seafood, meat, sausage, dairy products, ready meals.

In the humidity container:

Fig. 1/19

- Vegetables (e.g. carrots, asparagus, celery, leeks, beetroot, mushrooms, brassicas such as broccoli, cauliflower, Brussels sprouts, kohlrabi)
- Salad greens (e.g. lamb's lettuce, iceberg lettuce, chicory, lettuce)
- Herbs (e.g. dill, parsley, chives, basil)
- Fruit (types insensitive to cold, e.g. apples, peaches, berries, grapes)

Storage times (at 0 °C)

Depending on the initial quality

Fresh fish, seafood	up to 3 days
Poultry, meat (boiled/fried)	up to 5 days
Beef, pork, lamb, sausage (cold meat)	up to 7 days
Smoked fish, broccoli	up to 14 days
Salad greens, fennel, apricots, plums	up to 21 days
Soft cheese, yoghurt, quark, buttermilk, cauliflower	up to 30 days

Interior fittings

(not all models)

Glass shelf “EasyLift”

Fig. 4

The height of the glass shelf can be adjusted without taking it out.

Pull right lever to move the shelf upwards. Pull left lever to move the shelf downwards.

Notes

- Only ever press one lever.
- If a load exceeds 5 kg, the position of the shelf can no longer be changed.

Fixed glass shelf

Fig. 5

To change the position of the fixed glass shelf, press buttons on the underside and detach the glass shelf from the fixing. Reposition stopper. Re-insert glass shelf and fix by applying light pressure.

Door shelf “EasyLift”

Fig. 6

The height of the door shelves can be adjusted without taking them out.

Simultaneously press up the buttons on the underside of the door shelves to move the door shelves downwards. They can be moved upwards without pressing the buttons.

Bottle shelf

Fig. 7

Bottles can be stored securely on the bottle shelf. The holder can be adjusted.

Switching off and disconnecting the appliance

Switching off the appliance

Fig. 1

Press the On/Off button 6.
Refrigerating unit and light switch off.

Disconnecting the appliance

If you do not use the appliance for a prolonged period:

1. Switch off the appliance.
2. Pull out mains plug or switch off fuse.
3. Clean the appliance.
4. Leave the appliance door open.

Defrosting

Refrigerator and “cool-fresh” compartments

While the appliance is running, condensation droplets or frost form on the rear panel of the refrigerator compartment. As the rear panel defrosts automatically, it is not necessary to remove the frost or the condensation droplets. The condensation runs through the condensation channel and the drainage hole to the evaporation pan where it evaporates.

Note

Keep the condensation channel and drainage hole clean, so the condensation can drain off. Fig. 8

Cleaning the appliance

Caution

- Do not use abrasive, chloride or acidic cleaning agents or solvents.
- Do not use scouring or abrasive sponges. The metallic surfaces could corrode.
- Never clean shelves and containers in the dishwasher. The parts may become deformed!

Proceed as follows:

1. Before cleaning: Switch off the appliance.
2. Pull out mains plug or switch off fuse.
3. Take out the food and store in a cool location. Place ice pack (if available) on the food.
4. Wait until the layer of frost has thawed.
5. Clean the appliance with a soft cloth, lukewarm water and a little pH neutral washing-up liquid. The rinsing water must not run into the light or through the drainage hole into the evaporation pan.
6. Wipe the door seal with clear water only and then wipe dry thoroughly.
7. After cleaning reconnect and switch the appliance back on.
8. Put the food back into the appliance.

Notes

- Regularly clean the condensation channel and drainage hole, Fig. **3**/B, with a cotton bud to ensure that the condensation can drain. The water conduction channel, Fig. **8**/A, can be taken out for cleaning.

- After cleaning, the stopper must be re-inserted into the drainage hole of the refrigerator compartment for functional reasons.

Interior fittings

All variable parts of the appliance can be taken out for cleaning.

Taking out the glass shelf “EasyLift” Fig. **4**

Move glass shelf all the way upwards and take out.

Taking out the door shelf “EasyLift” Fig. **6**

Move door shelf all the way upwards and take out.

Taking out the fixed glass shelf Fig. **5**

Press buttons on the underside and detach from the fixing.

Removing the container Fig. **9**

Tilt container forwards and take out.

To insert the container, place the front of the container on the telescopic rails and push into the appliance.

The container is engaged by pushing it into the appliance.

Taking out the humidity filter Fig. **1**/18

The humidity filter over the humidity container can be taken out for cleaning. To do this, first take out the humidity container and pull out the humidity filter. Lift off the filter cover, Fig. **10**, and take out the filter. Clean in lukewarm water, leave to dry and re-assemble.

Remove telescopic rails

Fig. 12

1. Pull out the telescopic rail.
2. Push lock in the direction of the arrow.
3. Detach telescopic rail from the rear pin.
4. Push telescopic rail together, push backwards above the rear pin and disengage.

Installing telescopic rails

1. Place the extended telescopic rail on the front pin.
2. Pull the telescopic rail forwards slightly until it engages.
3. Place telescopic rail on the rear pin.
4. Push lock backwards.

Odours

If you experience unpleasant odours:

1. Switch off the appliance with the On/Off button. Fig. 11/6.
2. Take all food out of the appliance.
3. Clean interior (see chapter “Cleaning the appliance”).
4. Clean all packages.
5. Seal strong smelling food in order to avoid odours from forming.
6. Switch the appliance on again.
7. Store food in the appliance.
8. Check whether the formation of odours is still occurring after 24 hours.
9. Change odour filter, Fig. 11.

The odour filter is situated behind the upper “cool-fresh” container. Replacement filters are available from your customer service.

Light (LED)

Your appliance features a maintenance-free LED light.

These lights may be repaired by customer service or authorised technicians only.

Tips for saving energy

- Install the appliance in a dry, well ventilated room! The appliance should not be installed in direct sunlight or near a heat source (e.g. radiator, cooker).
If required, use an insulating plate.
- Allow warm food and drinks to cool down before placing in the appliance.
- Thaw frozen food in the refrigerator compartment and use the low temperature of the frozen food to cool refrigerated food.
- Open the appliance as briefly as possible.
- To prevent increased power consumption, occasionally clean the ventilation opening with a paint brush or vacuum cleaner.
- The arrangement of the fittings does not affect the energy rating of the appliance.

Operating noises

Quite normal noises

Droning

Motors are running (e.g. refrigerating units, fan).

Bubbling, humming or gurgling noises

Refrigerant is flowing through the tubing.

Clicking

Motor, switches or solenoid valves are switching on/off.

Preventing noises

The appliance is not level

Please align the installation cavity with a spirit level. To do this, use the height-adjustable feet of the cavity or place something underneath.

Containers or storage areas wobble or stick

Please check the removable parts and re-insert them correctly if required.

Receptacles are touching each other

Move the receptacles slightly away from each other.

Eliminating minor faults yourself

Before you call customer service:

Please check whether you can eliminate the fault yourself based on the following information.

Customer service will charge you for advice – even if the appliance is still under guarantee!

Fault	Possible cause	Remedial action
Temperature differs greatly from the set value.		In some cases it is adequate to switch off the appliance for 5 minutes. If the temperature is too high wait a few hours and check whether the temperature has approached the set value. If the temperature is too low check the temperature again the next day.
Bottom of the refrigerator compartment is wet.	The condensation channel or drainage hole are blocked.	Clean the condensation channel and the drainage hole. See chapter Cleaning the appliance. Fig. 8
The temperature in the refrigerator compartment is too cold.	Temperature has been set too low.	Increase the temperature.
The refrigerating unit is switching on more frequently and for longer.	Appliance opened frequently.	Do not open the appliance unnecessarily.
	The ventilation openings have been covered.	Remove obstacles.

Fault	Possible cause	Remedial action
Appliance has no refrigeration capacity.	Appliance has been switched off.	Press the On/Off button.
The light does not work.	Power failure.	Check whether the power is on.
The display does not illuminate.	The fuse has been switched off.	Check the fuse.
	The mains plug has not been inserted properly.	Check whether the mains plug is secure.
Appliance is not cooling, temperature display and light are lit.	Showroom mode is switched on.	<p>Hold down alarm button, Fig 2/1, for 10 seconds until an acknowledgement signal sounds.</p> <p>After a short time check whether your appliance is cooling.</p>
The light does not function.	The LED light is defective.	See chapter “Light (LED)” section.
	Appliance was open too long.	When the appliance is closed and opened, the light is on again.
	Light is switched off after approx. 10 min.	
The “cool-fresh” compartment is too warm or too cold.	The standard setting has been set too high or too low (e.g. if there is frost in the “cool-fresh” compartment).	<p>The temperature in the “cool-fresh” compartment can be set to be 2 steps warmer and/or colder, Fig. 2. If the refrigerator compartment temperature is set to 4, the “cool-fresh” compartment has a temperature of almost 0 °C.</p> <ol style="list-style-type: none"> 1. Press super button on refrigerator compartment 2 for 3 seconds until a signal sounds. Temperature display on refrigerator compartment 4 flickers. 2. Change the setting using the temperature setting button on refrigerator compartment 3. Setting 2 – coldest setting Setting 8 – warmest setting The set temperature is saved after one minute.

Fault	Possible cause	Remedial action
Temperature display for the refrigerator compartment flashes. Fig. 2/4	Appliance opened frequently.	Do not open the appliance unnecessarily.
	Too much food was placed in the compartment.	Before placing food in the freezer, press the super button 2.
	The airing and ventilation openings are blocked.	Remove obstacles.

Customer service

Your local customer service can be found in the telephone directory or in the customer-service index. Please provide customer service with the appliance product number (E-Nr.) and production number (FD).

These specifications can be found on the rating plate. Fig. 13

To prevent unnecessary call-outs, please assist customer service by quoting the product and production numbers. This will save you additional costs.

Repair order and advice on faults

Contact information for all countries can be found on the enclosed customer service list.

GB	0344 892 8999	Calls charged at local or mobile rate.
IE	01450 2655	0.03 € per minute at peak. Off peak 0.0088 € per minute.
US	866 447 4363	toll-free

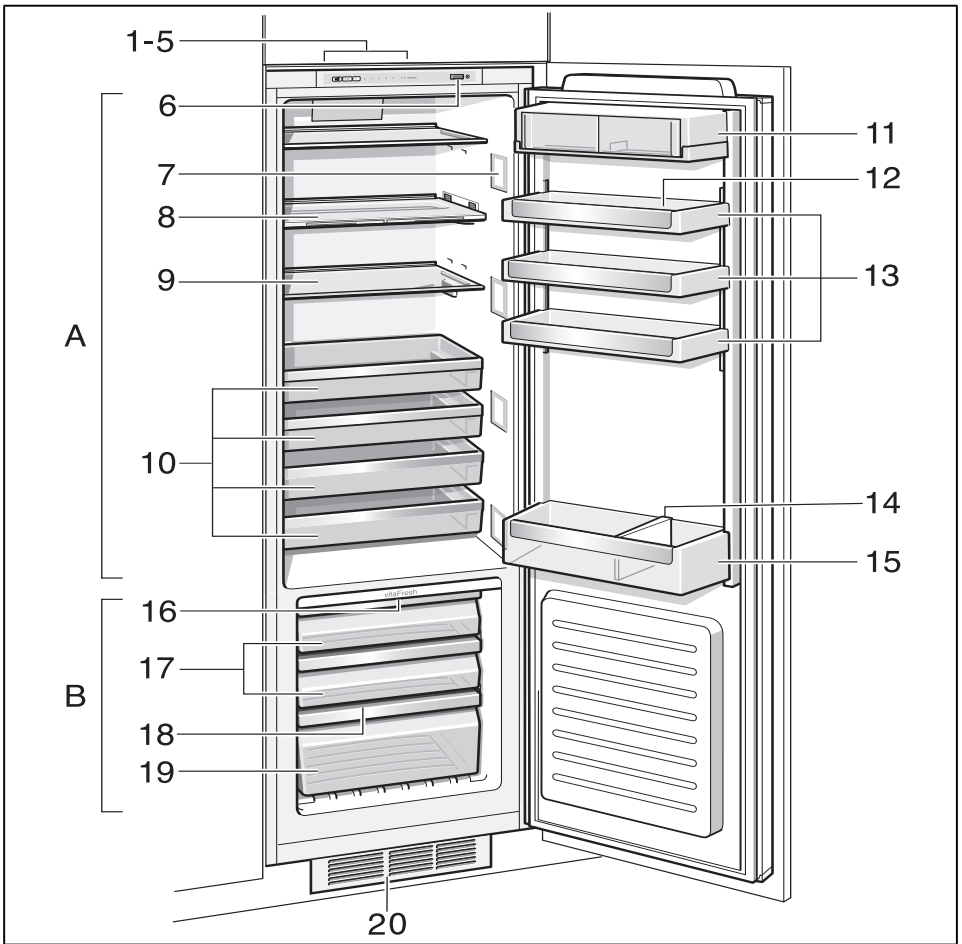

1

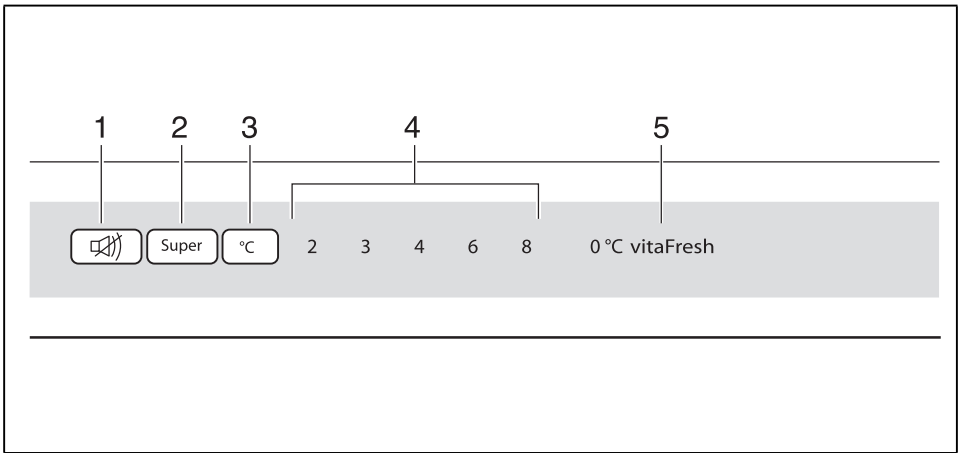

2

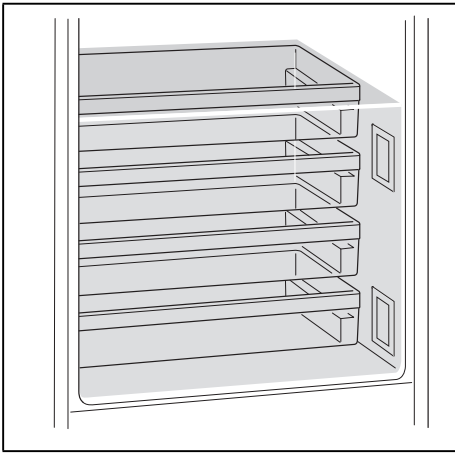

3

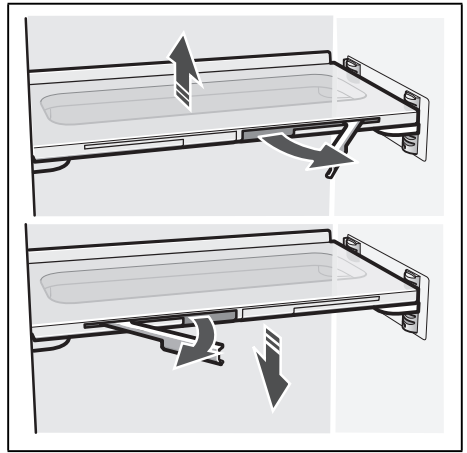

4

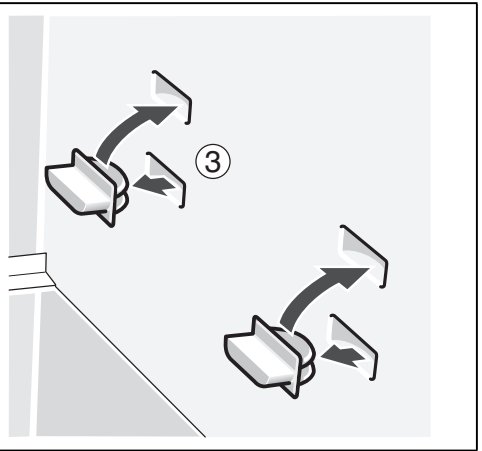
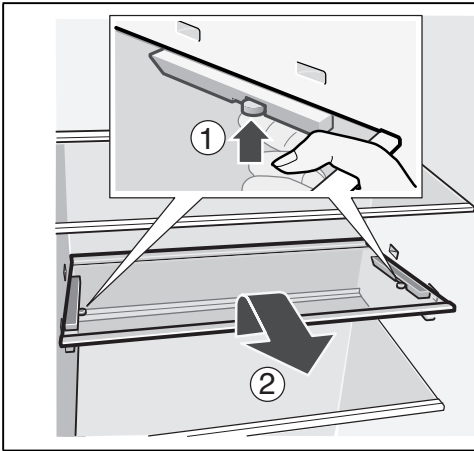

5

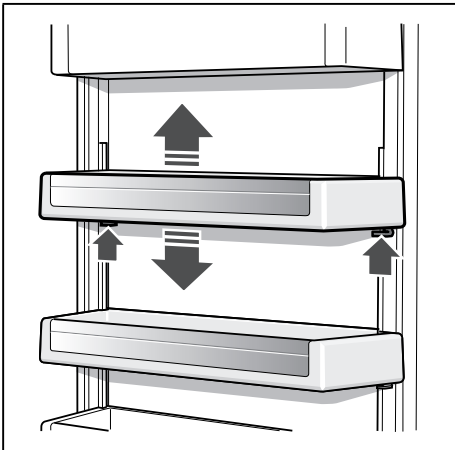

6

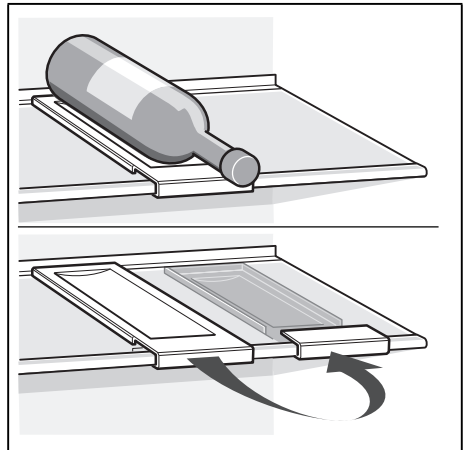

7

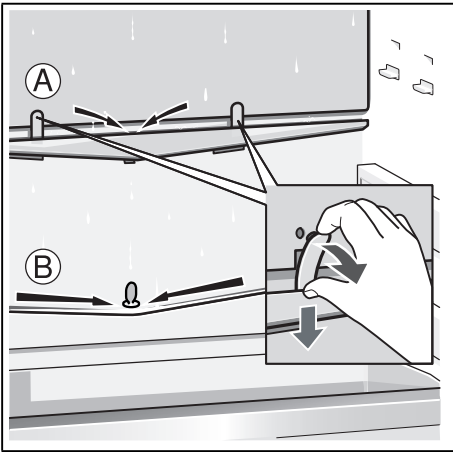

8

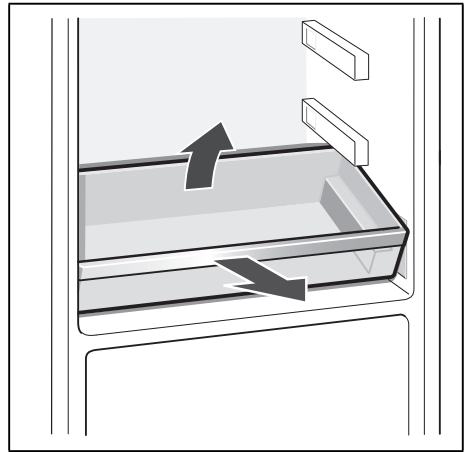

9

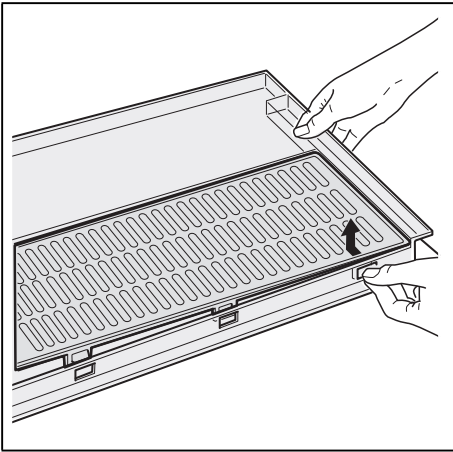

10

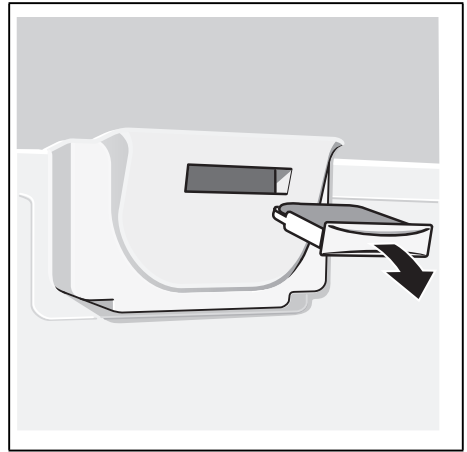

11

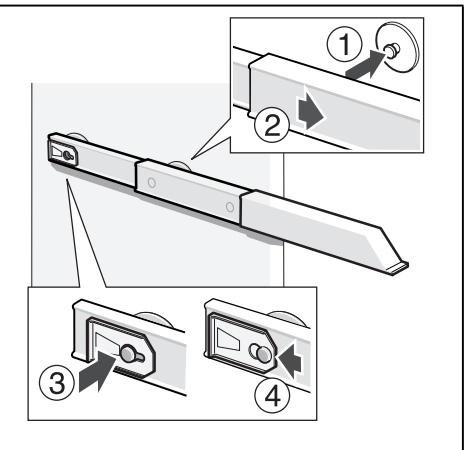
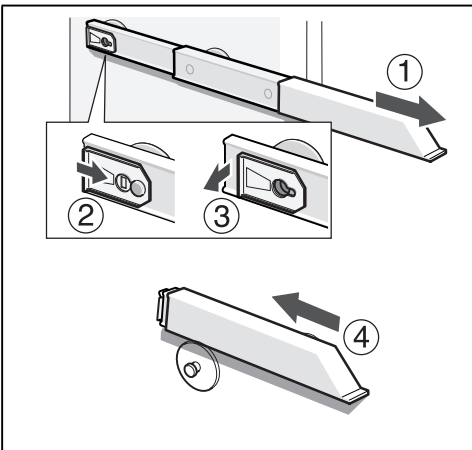

12

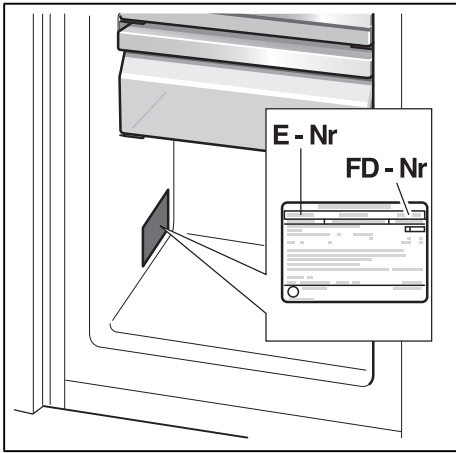

BSH Hausgeräte GmbH
Carl-Wery-Straße 34
81739 München, GERMANY

siemens-home.bsh-group.com

Manufactured by BSH Hausgeräte GmbH under Trademark License of Siemens AG



9000981163 (9511)

en