

Thermador

Welcome
To Your Thermador®
Pro Grand® Steam Range
The Ultimate Culinary Center™



Table of Contents

Welcome to Your THERMADOR Pro Grand® Steam Range	1	Using The Steam Oven	43
Safety	3	Extended Cooking Functions	45
Important Safety Instructions	3	Operating Your Steam Oven	50
Getting Started with Your Range	11	EasyCook Automatic Programming	54
Introduction	13	EasyCook Program Charts	56
Model and Parts Identification	13	Getting the Most Out of Your Steam Oven	58
Before You Begin	15	Using The Warming Drawer	71
Using The Cooktop	17	Care And Maintenance.	75
Using the STAR® Burners	19	Self-Cleaning the Main Oven	77
Cookware Recommendations	24	Cleaning the Cooktop and the Range Exterior	78
Specialty Cookware	25	Cleaning Recommendations	79
Surface STAR Burner Cooking Guide	26	Do-It-Yourself Maintenance	84
Using the Electric Griddle	27	Steam Oven Cleaning and Maintenance	86
Griddle Cooking Guide	28	Before Calling For Service	88
Using The Convection Oven.	31	Statement of Limited Product Warranty.	89
Extended Cooking Functions	33	THERMADOR® Support	91
Oven Functions	35		
Setting Bake & Conv. Bake, Roast & Conv. Roast.	36		
Convection Baking Guide	39		
Keep Warm	39		
Other Uses of Bake	40		
Broil/Convection Broil	41		
Broiling and Roasting Guide	42		

This THERMADOR® appliance is made
by BSH Home Appliances Corporation
1901 Main Street, Irvine, CA

Questions?

1-800-735-4328

www.thermador.com

We look forward to hearing from you!



Welcome

To Your Thermador® Pro Grand® Steam Range

The Ultimate Culinary Center™

Congratulations on your recent THERMADOR purchase! Whether you are a dedicated chef or simply a connoisseur of the art of cooking, owning a THERMADOR kitchen is the ultimate expression of personal style, good taste, and an appreciation for the complete culinary experience. Our award-winning products have been empowering culinary enthusiasts for more than eleven decades.

Before you begin using your new THERMADOR product, please take a moment to review the Use and Care Guide. You will find the answers to all of your questions as well as some very important safety information. Pay special attention to the **Important Safety Instructions** located at the beginning of the manual. Your THERMADOR product is ready and waiting to be used for your next gourmet creation!

Our products are handcrafted with the highest quality authentic materials to ensure years of reliable service. In the unlikely even that you have a service question, please have your model and serial numbers of your product available. You can find this information by opening the oven door and pulling the tab on the label mounting plate located on the right side of the range.

We realize that you have made a considerable investment in your kitchen. Please feel free to share your THERMADOR kitchen photos and remodeling stories with us. Follow us on Twitter or post your kitchen photos to Facebook. We would love to hear from you!

Safety



Important Safety Instructions

READ AND SAVE THESE INSTRUCTIONS

Please Read and Follow



WARNING:

If the information in this manual is not followed exactly, a fire or explosion may result causing property damage, personal injury or death.

- Do not store or use gasoline or other flammable vapors and liquids in the vicinity of this or any other appliance.
- WHAT TO DO IF YOU SMELL GAS
 - Do not try to light any appliance.
 - Do not touch any electrical switch.
 - Do not use any phone in your building.
 - Immediately call your gas supplier from a neighbor's phone. Follow the gas supplier's instructions.
 - If you cannot reach your gas supplier, call the fire department.
- Installation and service must be performed by a qualified installer, service agency or the gas supplier.



WARNING:



A child or adult can tip the range over and be killed. Verify that the anti-tip bracket is securely installed. Ensure the anti-tip bracket is engaged when the range is moved.

Do not operate the range without the anti-tip bracket in place. Failure to follow the instructions in this manual can result in death or serious burns to children and adults.

Check for proper installation and use of anti-tip bracket. Carefully tip range forward pulling from the back to ensure that the anti-tip bracket engages the range aluminum cast base and prevents tip-over. Range should not move more than 1 inch (2.5cm).

Gas and Electrical Requirements and Grounding Instructions

Gas Type Verification

Verify the type of gas supplied to the location. Ensure that the appliance is connected to the type of gas for which it is certified. All models are certified for use with natural gas. Field conversion of the appliance for use with propane gas supply will require a conversion kit (included). Make certain your range and gas type are the same. Refer to the product rating label which can be located as indicated in Figure 1 on Page 88.



CAUTION:

When connecting the unit to propane gas, make certain the propane gas tank is equipped with its own high-pressure regulator in addition to the pressure regulator supplied with the range. The maximum gas pressure to this appliance must not exceed 14.0" water column (34.9 mb) from the propane gas tank to the pressure regulator.

IMPORTANT:

When installing against a combustible surface, a High Shelf or Low Back guard is required. A THERMADOR® High Shelf or Low Back guard must be purchased separately. Before using the range, insure that it is equipped with a proper back guard. Refer to the *Installation Manual* accompanying this appliance for more information.



WARNING:

To avoid possible burn or fire hazard, a back guard designed specifically for this range must be installed whenever the range is used.

Electrical Rating:

240/208 volts, 60 Hz., 50 Amp electrical circuit required.



Important Safety Instructions

READ AND SAVE THESE INSTRUCTIONS



CAUTION:

The high shelf can get very hot! **DO NOT** place the following items on top of the high shelf:

- plastics or containers that can melt
- flammable items
- a total load over 30 lbs. (13.6 kg)



WARNING:

ALWAYS DISCONNECT THE ELECTRICAL PLUG FROM THE WALL RECEPTACLE BEFORE SERVICING THIS UNIT.



CAUTION:

FOR PERSONAL SAFETY, THIS APPLIANCE MUST BE CONNECTED TO A PROPERLY GROUNDED AND POLARIZED ELECTRICAL POWER SUPPLY.

It is recommended that a dedicated circuit servicing this appliance be provided.

The use of gas cooking appliances results in the production of heat and moisture.

See the *Installation Manual* for electrical requirements and grounding instructions.

It is the personal responsibility and obligation of you, the user, to have this appliance connected to the electrical power supply by a qualified electrician, in accordance with the National Electrical Code and/or applicable local codes and ordinances.



WARNING:

IN CASE OF AN ELECTRICAL FAILURE

If for any reason a gas control knob is turned ON and there is no electrical power to operate the electronic igniters on the range's cooktop STAR[®] burners, **turn OFF the gas control knob and wait 5 minutes** for the gas to dissipate before lighting the STAR burner manually.

To light the STAR burners manually, carefully hold a lighted match to the STAR burner ports and turn the gas control knob to HI. During a power failure, you can use the standard cooktop STAR burners, but each must be lit with a match.

DO NOT attempt to light the two left XLO[®] STAR burners and two right XLO STAR burners manually.

These STAR burners are equipped with the ExtraLow[®] feature and cannot be lit manually.

TESTED IN ACCORDANCE WITH:

- ANSI Z21.1 for Household Gas Appliances
- UL858 for Household Electric Ranges
- CAN/CSA-22.2 No. 61-M89 for Household Cooking Ranges
- CAN/CGA 1.1-M81 Domestic Gas Ranges

Check your local building codes for the proper method of installation. In the absence of local codes, this unit should be installed in accordance with the National Fuel Gas Code No. Z223.1 current issue and the National Electrical Code ANSI/NFPA No. 70 current issue or the Can - B149 Installation Codes for Gas Burning Appliances and C22.1 Canadian Electrical Code Part 1.

It is the responsibility of the owner and the installer to determine if additional requirements and/or standards apply to specific installations.



Important Safety Instructions

READ AND SAVE THESE INSTRUCTIONS

When properly cared for, your new THERMADOR PROFESSIONAL® range has been designed to be a safe, reliable appliance. However, use extreme care when using this restaurant caliber range as this type of appliance provides intense heat. When using kitchen appliances, basic safety precautions must be followed, including the following:

Read this Use and Care Manual carefully before using your new range, to reduce the risk of fire, electrical shock, or injury to persons.

Insure proper installation and servicing. Follow the *Installation Manual* provided with this product. Have the range installed and electrically grounded by a qualified technician.

Have the installer show you where the electric circuit breaker and the gas supply shut off valve are located so you know how and where to turn off the gas and electricity to the range.

In the event a STAR® burner goes out and gas escapes, open a window or a door. **DO NOT** attempt to use the range until the gas has had time to dissipate. Wait at least 5 minutes before using the range.

DO NOT repair or replace any part of the appliance unless specifically recommended in this manual. All other servicing should be referred to a qualified technician.

Child Safety

When children become old enough to use the appliance, it is the legal responsibility of the parents or legal guardians to ensure that they are instructed in safe operation of the appliance by qualified persons.

DO NOT allow anyone to climb, stand, lean, sit, or hang on any part of an appliance, especially a door, or the warming drawer. This can damage the appliance, and the unit may tip over, potentially causing severe injury.

DO NOT allow children to use this appliance unless closely supervised by an adult.

Children and pets should not be left alone or unattended in the area where the appliance is in use. They should never be allowed to play in its vicinity, whether or not the appliance is in use.



CAUTION:

Items of interest to children should not be stored in an appliance, in cabinets above an appliance, or on the backsplash. Children climbing on an appliance to reach items could be seriously injured.

NEVER use any part of the range or ovens for storage. Flammable materials can catch fire and plastic items may melt or ignite.

DO NOT hang articles from any part of the appliance or place anything against the ovens. Some fabrics are quite flammable and may catch on fire.

If the range is near a window, be certain the curtains do not blow over or near the range STAR burners; they could catch on fire.



WARNING:

TO REDUCE THE RISK OF A GREASE FIRE:

- **NEVER** leave surface units unattended at high settings. Boilovers cause smoking and greasy spillovers that may ignite. Heat oils slowly on low or medium settings.
- **ALWAYS** turn hood ON when cooking at high heat or when flambéing food (i.e. Crepes Suzette, Cherries Jubilee, Peppercorn Beef Flambé).
- Clean hood filters frequently. Grease should not be allowed to accumulate on fan or filter.

Use proper pan size. **ALWAYS** use cookware appropriate for the size of the cooktop STAR burner.

ALWAYS have a working smoke detector near the kitchen.

In the event that personal clothing or hair catches fire, drop and roll immediately to extinguish flames.

Have an appropriate fire extinguisher available, nearby, highly visible and easily accessible near the cooking appliance.



Important Safety Instructions

READ AND SAVE THESE INSTRUCTIONS

Smother flames from food fires, other than grease fires, with baking soda. **NEVER** use water on cooking fires.

Whenever possible, **DO NOT** operate the ventilation system during a cooktop fire. However, **DO NOT** reach through fire to turn it off.



WARNING:

TO REDUCE THE RISK OF INJURY TO PERSONS, IN THE EVENT OF A RANGE TOP GREASE FIRE, OBSERVE THE FOLLOWING:

- Smother flames with a close-fitting lid, cookie sheet, or other metal tray, then turn off the gas STAR[®] burner or the electric element. Be careful to prevent burns. If the flames do not go out immediately, evacuate and call the fire department.
- **NEVER** pick up a flaming pan — You may be burned.
- **DO NOT USE WATER**, including wet dish cloths or towels — a violent steam explosion will result.
- Use an extinguisher only if:
 - You know you have a class ABC extinguisher and you already know how to operate it.
 - The fire is small and contained in the area where it started.
 - The fire department is being called.

You can fight the fire with your back to an exit.

NEVER let clothing, potholders, or other flammable materials come in contact with or too close to any infrared burner, top burner, or burner grate until it has cooled. Fabric may ignite and result in personal injury.

Use only dry potholders; moist or damp potholders on hot surfaces may cause burns from steam. **DO NOT** use a towel or other bulky cloth in place of potholders. **DO NOT** let potholders touch hot elements, hot burners, or burner grates.

For personal safety, wear proper apparel. Loose fitting garments or hanging sleeves should **NEVER** be worn while using this appliance. Some synthetic fabrics are highly flammable and should not be worn while cooking.

DO NOT use aluminum foil to line any part of the ovens or range. Use of a foil liner could result in a shock or fire hazard, or the obstruction of the flow of combustion and ventilation air. Foil is an excellent heat insulator and heat will be trapped beneath it. This will upset the cooking performance and can damage the finish of the ovens or the range.



WARNING:

RANGE TIPPING HAZARD:

- All ranges can tip and injury can result. To prevent accidental tipping of the range, attach it to the floor, wall, or cabinet by installing the Anti-Tip Device supplied.
- A risk of tip-over may exist if the appliance is not installed in accordance with these instructions.
- If the range is pulled away from the wall for cleaning, service, or any other reason, ensure that the Anti-Tip Device is properly reengaged when the range is pushed back against the wall. In the event of abnormal usage (such as a person standing, sitting, or leaning on an open door), failure to take this precaution can result in tipping of the range. Personal injury might result from spilled hot liquids or from the range itself.



WARNING:

NEVER use this appliance as a space heater to heat or warm the room. Doing so may result in carbon monoxide poisoning and overheating of the ovens.



WARNING:

NEVER cover any slots, holes, or passages in the ovens bottom or cover an entire rack with materials such as aluminum foil. Doing so blocks air flow through the ovens. Aluminum foil linings may also trap heat, causing a fire hazard.



WARNING:

The appliance is for cooking. Based on safety considerations, **NEVER** use the ovens or cooktop to warm or heat a room. Also, such use can damage the cooktop or oven parts.



Important Safety Instructions

READ AND SAVE THESE INSTRUCTIONS

When using the cooktop: **DO NOT TOUCH THE BURNER GRATES OR THE IMMEDIATE SURROUNDING AREA.**

Areas adjacent to the STAR[®] burners may become hot enough to cause burns.

NEVER leave the range unattended when using high flame settings. Boil overs cause smoking and greasy spillovers that may ignite. Also, if the STAR burner flames and igniter are smothered with spillage, unburned gas will escape into the room. See page 3 regarding gas leaks.

Only certain types of glass, heatproof glass-ceramic, ceramic, earthenware, or other glazed cookware are suitable for cooking on the range STAR burners. This type of cookware may break with sudden temperature changes. Use only on low or medium heat settings according to the utensil manufacturer's directions.

DO NOT heat or warm unopened food containers. Build-up of pressure may cause the container to burst and cause injury.

During cooking, set the STAR burner control so that the flame heats only the bottom of the pan and does not extend beyond the bottom of the pan.



WARNING:

Avoid using high flame setting with a pan larger than the grate or with one that spans more than one STAR burner, such as a griddle, for prolonged periods of time. This can result in poor combustion that generates harmful by-products.

Bakeware, such as large casserole pans, cookie sheets, etc., should **NEVER** be used on the cooktop.

Use caution to insure that drafts like those from forced air vents or fans do not blow flammable material toward the flames or push the flames so that they extend beyond the edges of the pot.

ALWAYS use pots and pans that have flat bottoms large enough to cover the STAR burner. The use of undersized pots and pans could expose a portion of the flame and may result in ignition of clothing.

DO NOT use flammable cleaners to clean the range.

To minimize the risk of burns, ignition of flammable materials, and unintentional spillage, position handles of

pots and pans inward so they do not extend over adjacent work areas, cooking areas, or the edge of the range's cooktop.

Hold the handle of the pan to prevent movement when stirring or turning food.

DO NOT use pots or pans on the griddle/grill plate accessory.

Remove the optional cutting board accessory, which is stored on top of the griddle plate, before operating the griddle or any adjacent STAR burners.

GREASE IS FLAMMABLE. Let hot grease cool before attempting to handle it. Avoid letting grease deposits collect. Clean after each use.

For proper lighting and performance of the STAR burners, keep the igniter ports clean. It is necessary to clean the ports when there is a boil over or when the STAR burner does not light even though the electronic igniters activate. See "Cleaning Recommendations" on page 79.



WARNING:

After a spill or boil over, turn off the STAR burner and clean around the STAR burner and burner ports. After cleaning, check for proper operation.

Clean the range with caution. Avoid steam burns; **DO NOT** use a wet sponge or cloth to clean the range while it is hot. Some cleaners produce noxious fumes if applied to a hot surface. Follow directions provided by the cleaner manufacturer.

Be sure all cooktop controls are turned off and the cooktop is cool before using any type of aerosol cleaner on or around the cooktop. The chemical that produces the spraying action could, in the presence of heat, ignite or cause metal parts to corrode.

DO NOT store or use corrosive chemicals, vapors, flammables or nonfood products in or near this appliance. It is specifically designed for use when heating or cooking food. The use of corrosive chemicals while heating or cleaning will damage the appliance and could result in injury.



Important Safety Instructions

READ AND SAVE THESE INSTRUCTIONS

When using the ovens **DO NOT** touch the broiler element, the interior surfaces of the ovens or the exterior area immediately surrounding the door. Interior oven surfaces become hot enough to cause burns. The heat deflector, which deflects heat away from the cooktop and the trim on the top and sides of the oven doors, will also be hot when the ovens are in use.

Place oven racks in desired position while ovens are cool. If a rack must be moved while the ovens are hot, **DO NOT** let the potholders contact the broiler element.

Use CAUTION when opening the oven door during or immediately after operation. Stand to the side of the oven when opening an oven door to allow hot air or steam to escape. Keep face well away from the open door to avoid injury.

Before self-cleaning the ovens, remove the broiler pan, oven racks, temperature probe and any other utensils, and excess spillage.

DO NOT clean, rub, damage, move, or remove the door gasket. It is essential for a good seal during baking. If the gasket becomes worn or excessively soiled with food particles, replace gasket to assure a tight seal.

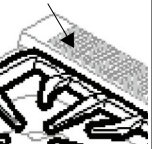
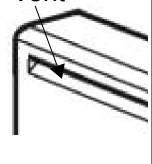
	 WARNING:
<p>Flush Island Trim Vent</p> 	<p>DO NOT block or obstruct the flow of air through the ventilation openings. The oven vent is located at the back of the appliance. The vents need to be unobstructed and open to provide necessary airflow that is important for proper oven performance.</p>
<p>Low Back Vent</p> 	<p>DO NOT touch oven vent area while the appliance is on and for several minutes after the appliance is off. Some parts of the vent and surrounding areas become hot enough to cause burns. Allow appliance sufficient time to cool before touching or cleaning vent areas.</p> <p>DO NOT position plastic or other heat-sensitive items on or near the oven vent. These items could melt or ignite.</p>

For safety reasons and to avoid damage to the range, **NEVER** sit, stand, or lean on the oven doors.

Service should only be done by authorized technicians. Technicians must disconnect the power supply before servicing this unit.

Listen to be sure the cooling blower runs whenever the oven controls are set to BROIL or BAKE modes, after ovens heat to 300°F (150°C) — see “Automatic operation of the cooling blower” on page 40. If the fans do not operate, **DO NOT** use the ovens. Call an authorized service center for service.

To avoid a fire hazard, grease accumulation must be prevented by frequently cleaning the ventilation hood and filters.

In case of fire or when intentionally “flaming” liquor or other spirits on the range’s cooktop, follow manufacturer’s instructions.

Use caution when cooking foods with high alcohol content (e.g. rum, brandy, bourbon) in the ovens. Alcohol evaporates at high temperatures. There is a risk of burning as the alcohol vapors may catch fire in the ovens. Use only small quantities of alcohol in foods, and open the oven doors carefully.

 WARNING:
<p>To avoid possible burn or fire hazard, a back guard designed specifically for this range must be installed whenever the range is used.</p>

IMPORTANT SAFETY NOTICE:

The California Safe Drinking Water and Toxic Enforcement Act requires the Governor of California to publish a list of substances known to the state to cause cancer, birth defects, or other reproductive harm, and requires businesses to warn customers of potential exposure to such substances.

The burning of gas cooking fuel can generate some by-products which are on the list. Exposure to these substances can be minimized by:

1. Providing good ventilation when cooking with gas.
2. Providing good ventilation during and immediately after self cleaning the oven.
3. Operating the unit according to the instructions in this manual.



Important Safety Instructions

READ AND SAVE THESE INSTRUCTIONS

Steam Oven Safety Practices

Baking and Steaming Safety



CAUTION:

Hot steam can escape during use. **DO NOT** touch the ventilation openings.



CAUTION:

Hot steam can escape when opening the oven door. Hot water may drip from the door. Keep children away.



CAUTION:

Use pot holders to remove inserted cooking accessories from the hot oven. Hot liquid may spill over when removing the cooking accessories.

The steam oven bottom and the evaporator dish must always remain clear. Always place ovenware on the rack or in the perforated cooking pan.

Ovenware must be heat and steam resistant. Silicone baking pans are not suitable for STEAM/CONVEC mode.

When using STEAM mode with a perforated cooking pan, always slide the baking pan underneath it. The pan will catch any drippings.

DO NOT store moist foods for an extended period of time in the closed steam oven. The food could cause corrosion of the oven interior.

DO NOT overfill very juicy fruit tarts with fruit when using the baking pan. The fruit juice that drips off the baking pan leaves behind stains that cannot be removed.

When using aluminum foil in the steam oven, **DO NOT** allow it to touch the glass on the door. This could cause permanent staining of the door glass.

DO NOT place anything on the open appliance door. This could damage the appliance.

The use of accessory attachments not recommended by THERMADOR® may cause injuries.

Cleaning Safety

DO NOT clean the steam oven while it is still hot. Some cleaners produce noxious fumes when applied to a hot surface. Wet cloths or sponges can cause burns from steam.

Risk of severe burns! DO NOT clean the steam oven immediately after turning it off. The water in the evaporator dish is still hot. Wait until the appliance has cooled down.

The door will no longer close properly if the door gasket is heavily soiled. The face of adjacent furnishings could become damaged. Always keep the door gasket clean and contact a THERMADOR Service Technician to replace if necessary.

The oven cavity is made of high quality stainless steel. Improper care may result in corrosion of the oven cavity. Follow the care and cleaning instructions provided in this manual. Remove food residue and spills from the cavity immediately after the steam oven has cooled down.

Ovenware Safety

DO NOT place food directly on oven bottom. Follow the manufacturer's directions.

Getting Started with Your Range



Introduction

THERMADOR PROFESSIONAL® ranges are freestanding units available in a number of configurations. This PRO GRAND® dual-fuel range features a cooktop with six gas STAR® burners and an electric griddle, a professional size, self-cleaning, electric convection oven with broil capability, a steam oven, and a warming drawer. The drawings that follow introduce you to the components of your new range.

Model and Parts Identification

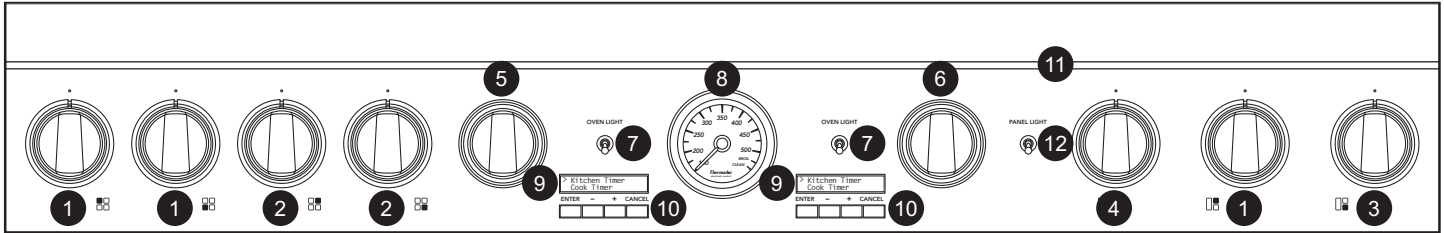
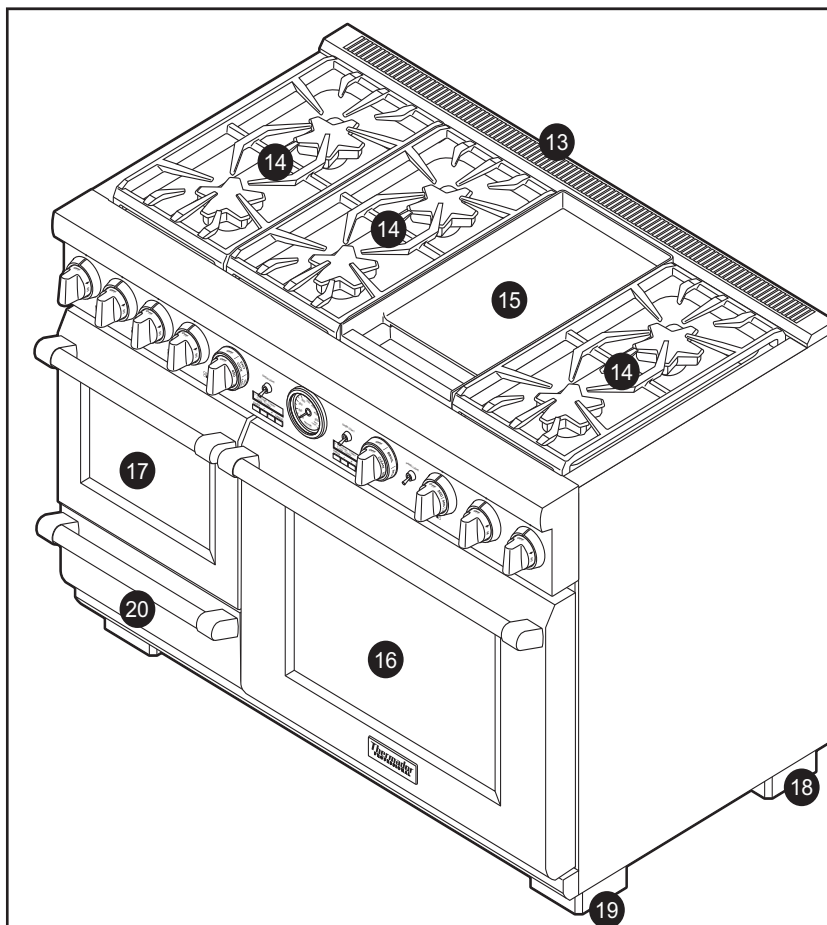

Figure 1: Control Panel



Key

1. Control Knobs, ExtraLow® STAR® Burners (3)
2. Control Knobs, Standard STAR Burners (2)
3. Control Knob, ExtraHigh™ and ExtraLow® (1)
4. Electric Griddle Knob (1)
5. Steam Oven Control Knobs
6. Main Oven Control Knobs
7. Oven Light Switches
8. Temperature Gauge
9. Oven Display Screens (2)
10. Oven Display Control Buttons (2)
11. Control Panel Light
12. Control Panel Light Switch
13. Flush Island Trim (included), High Shelf or Low Back (ordered separately)
14. Burner Grates & STAR Burners (6)
15. Electric Griddle
16. Main Oven (3 racks included)
17. Steam Oven (1 rack included)
18. Range Feet (4)
19. Leg Cover Assembly (4)
20. Warming Drawer



CAUTION:

To provide proper ventilation of the range, **DO NOT** remove range feet.

Figure 2: Range Identification

Model and Parts Identification

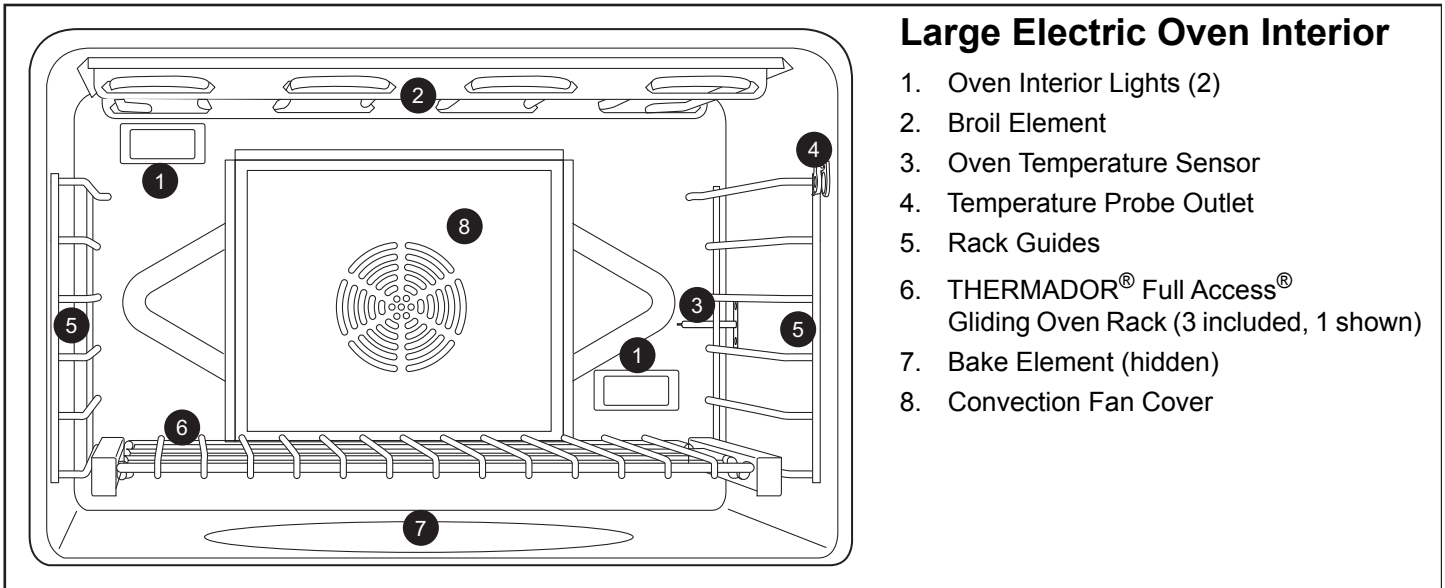

Large Electric Oven Interior

1. Oven Interior Lights (2)
2. Broil Element
3. Oven Temperature Sensor
4. Temperature Probe Outlet
5. Rack Guides
6. THERMADOR® Full Access® Gliding Oven Rack (3 included, 1 shown)
7. Bake Element (hidden)
8. Convection Fan Cover

Figure 3: Main Oven Interior

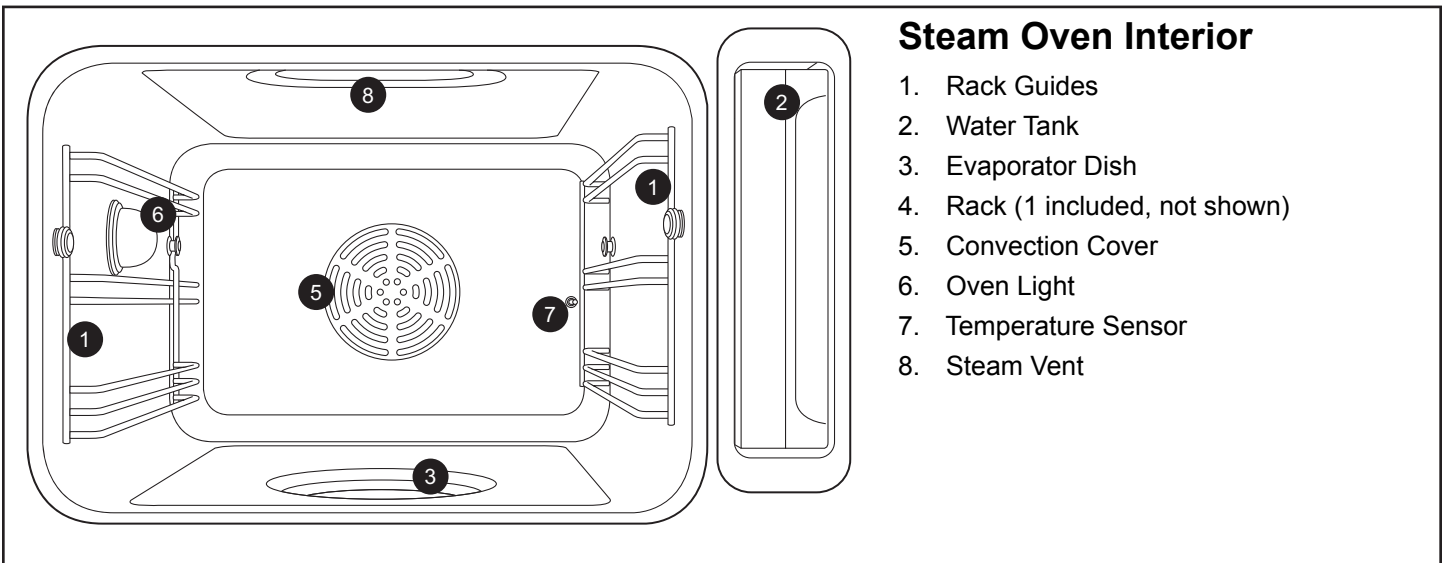

Steam Oven Interior

1. Rack Guides
2. Water Tank
3. Evaporator Dish
4. Rack (1 included, not shown)
5. Convection Cover
6. Oven Light
7. Temperature Sensor
8. Steam Vent

Figure 4: Steam Oven Interior

Before You Begin

Using Your Range for the First Time

Check that you have these items:

Table 1: Range Accessories and Parts

DESCRIPTION	Qty.
THERMADOR® Full Access® Gliding Oven Racks, Main Oven	3
Two-Piece Broil Pan	1
Temperature Probe	2
Wire Rack, Steam Oven	1
Perforated Cooking Pan, Full-Size, Steam Oven	1
Perforated Cooking Pan, Half-Size, Steam Oven	1
Cooking Pan, Half-Size, Steam Oven	1
Baking Pan, Full-Size, Steam Oven	1
STAR® Burner Caps	6
Burner Grates	3
Control Knobs	9
Titanium Coated Aluminum Griddle	1
Leg Cover Assemblies	4
Product Registration Card	1
Handy Hints Guide	1
Flush Island Trim*	1
LP Conversion Kit	1
Water Tank	1
Installation Manual	1
Use and Care Manual	1
Sponge	1

* The range is supplied with a Flush Island trim; however, see Warning concerning spacing behind the range when using the range with the Flush Island Trim.



Remove all packaging materials and temporary labels from oven and cooktop. Please, recycle the packaging material as all THERMADOR packaging is recyclable.

1. Check that you have the items listed above.
2. **Record the Model and Serial number on page 88.** See “Data Rating Labels” found on the Rating Label Plate. Rating plate is located on the right side of the range between the oven cavity and side panel (see Figure 1 on Page 88). These may be used for any future contacts with Customer Service. Enter this information on the Product Registration Card included with this product then mail it to the indicated address.
3. **Optional Accessories:** Grill Plate (*PA12GRILHC*), 12” Cutting Board (*PA12CHPBLK*), Griddle/Grill Cover (*PA12CVRJ*), Wok Support Ring (*PWOKRINGHC*), Toe Kick (*PA48JTKG*) and other accessories are available from your THERMADOR Dealer.
4. **Position the racks correctly in the oven.** The correct rack position depends on the recipe and the cooking mode. The rack positions are numbered from the bottom of the oven, like an elevator. Rack position 3 is the most frequently used position. Place rack(s) in the proper position before turning on the oven.

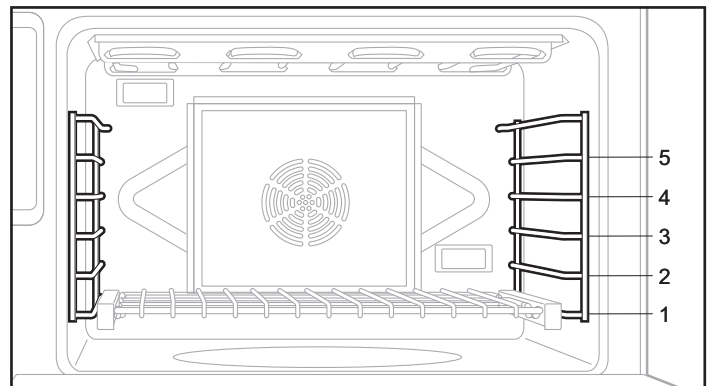

Figure 5: Large Oven Rack Positions

5. **THERMADOR Full Access® gliding oven racks are standard on all models.** Each gliding oven rack can be pulled out and pushed back into the oven with minimal effort — even while supporting a large turkey or roast.
6. **Ensure that the STAR® burner caps are correctly seated on the burner bases of the range's cooktop.** Turn on each STAR burner to check for proper flame color. See “Flame Description” on page 23 for details.

IMPORTANT:

ALWAYS remove the gliding oven racks before self-cleaning the oven. If the gliding racks remain in the oven during Self-Clean, lubricants in the glide mechanisms of each rack will be lost and the finish will discolor.



WARNING:

To help prevent burns, **NEVER** remove or reposition the oven racks while the oven is ON or while the oven is cooling.

The THERMADOR PROFESSIONAL® range occasionally has a smell or smoke when first used. These smells or smoke comes from the burning off of manufacturing residues and is typical of any new oven regardless of manufacturer. **Before baking or broiling**, the convection oven and broiler should be turned on to burn off the manufacturing oils using one of the two following methods:

1. Turn on kitchen ventilation (or if vent hood is a recirculation type, open a window). Set oven at 500°F (260°C) and let the oven go through a 2-hour cycle at high heat then shut off the oven. Please read “Care and Maintenance” on page 77 before cleaning the oven racks.
2. Turn on kitchen ventilation (or if vent hood is a recirculation type, open a window). Run the Self-Clean cycle.

Please note that pet birds can be sensitive to the odors created during any high heat cooking whether it is a manufacturing residue burn off or food so it is recommended that birds are removed from the kitchen area.

Before using the steam oven for the first time, clean it using the STEAM mode for 20 minutes following the instructions on page 49.

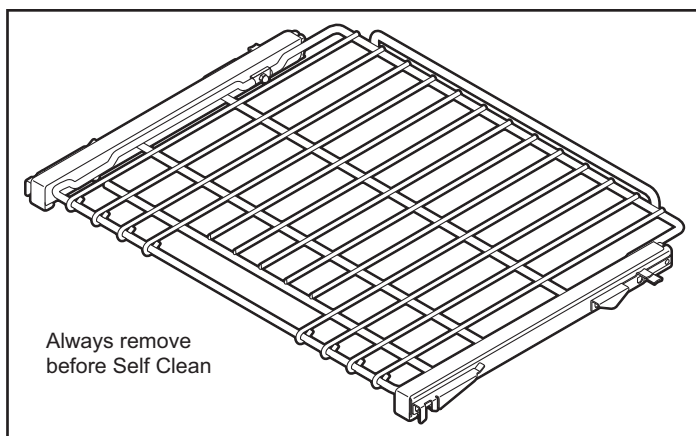

Figure 6: Gliding Oven Rack

Placing Rack in Oven:

To insert a rack in the oven, hold the rack with the back rail up toward the back. Place the safety hooks under the front of the rail guides. Push the rack into the oven, lifting the rack stops over the front of the rail guides. Slide the rack into position.

When placing food on a rack, pull the rack out to the stop position. The racks are designed to lock and not tilt while in fully-extended position.

Removing Rack from Oven:

To remove or reposition a rack in the oven, pull the rack toward the front of the oven. Lift up the front of the rack over the safety stops and pull the rack from the oven.

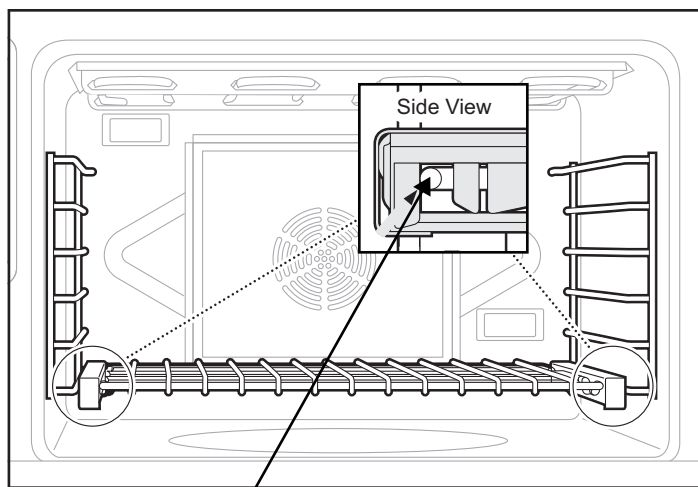

Figure 7: View of Rack on the Rack Guide

IMPORTANT:

When placing the gliding rack in the oven, make sure the front supports on the rack guides rest in the large slots at the front corners of the rack, as shown. This is necessary to keep the rack in the correct position while fully inserted into the oven.



CAUTION:

Aluminum foil should **NEVER** be used to cover the oven racks or to line the oven. **DO NOT** remove the broiler element in the electric oven.

Note:

It is normal for the cooling process to push heated air out into the room when the oven is on.

Using the Cooktop



Using the STAR[®] Burners

Sealed STAR[®] Burners

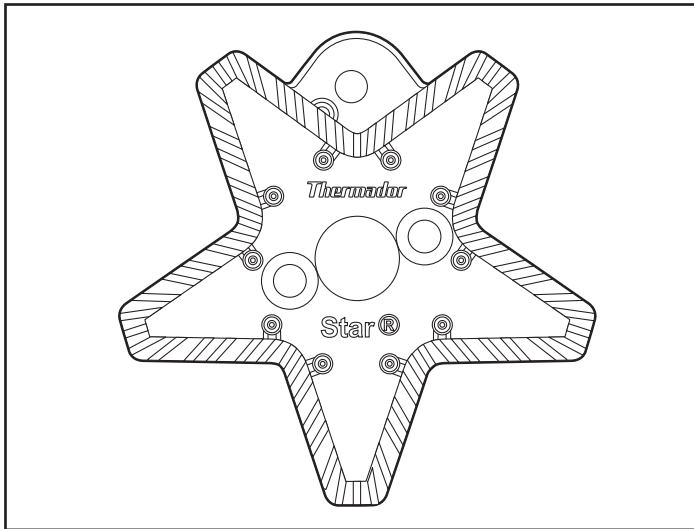

Figure 8: STAR Brass Burner Base

The cooktop features six gas surface STAR burners; each rated at 18,000 BTU / HR (15,000 BTU / HR using propane). The STAR burners are mounted on top of unique-shaped pedestals; this makes the STAR burner assemblies easier to clean.

Each STAR burner has a unique QuickClean™ Base feature which allows the burner and area around the burner assembly to be easier to clean.

The two left and two right STAR burners have the exclusive ExtraLow[®] simmering feature, any remaining STAR burners are Standard. Each STAR burner has its own control knob.

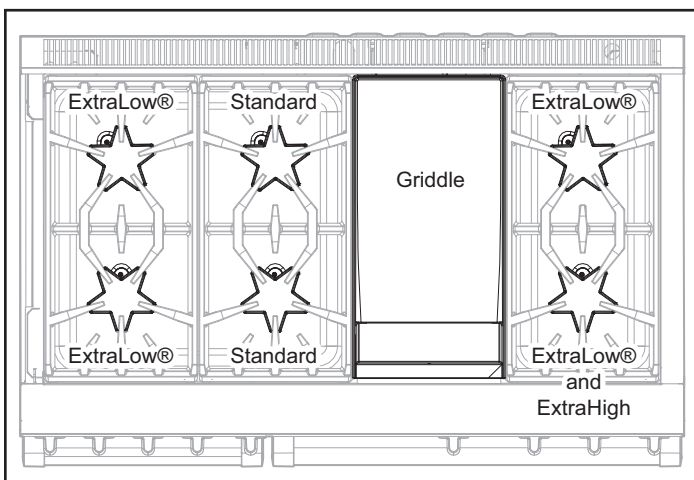

Figure 9: Burner Power Features

Control Knobs

A pair of control knobs is located on the control panel, directly in front of the pair of gas STAR burners they control — with one gas STAR burner positioned in front of the other on the rangetop.

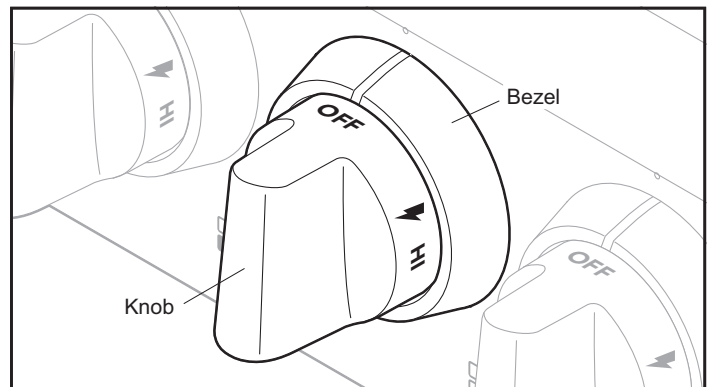

Figure 10: Standard STAR Burner Control Knob

The symbol near each STAR burner control knob identifies the STAR burner position on the range cooktop.

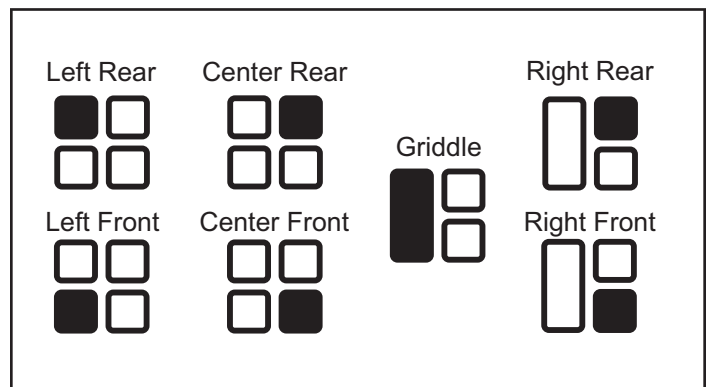

Figure 11: Cooktop Symbols

Operation of the STAR[®] Burners

- Press in on the knob and turn it counter-clockwise to the HI setting.
- The igniter for the selected STAR burner sparks to ignite the burner.
- After flame ignition, the igniter stops sparking.
- Rotate the knob to any flame setting between HI and SIM.
- A blue light is positioned directly above each STAR burner control knob. The light turns on when the control knob is rotated to an active mode. It is off when the control knob is in the OFF position.

BTU Output for Standard STAR® Burners

- HI is equivalent to 18,000 BTU / HR (15,000 BTU / HR using propane).
- SIM is equivalent to 2,100 BTU / HR. BTU

Output for ExtraLow® STAR Burners

- SIM is equivalent to 3,000 BTU / HR.
- XLO® is equivalent to 375 BTU / HR when the control knob is adjusted to the lowest setting in the ExtraLow® range.

BTU Output for POWERBOOST® (XHI)

- XHI for the POWERBOOST is equivalent to 22,000 BTU / HR (18,000 BTU / HR using propane).
- SIM is equivalent to 3,000 BTU / HR
- XLO is equivalent to 375 BTU / HR

ExtraLow® STAR® Burners

The controls for the two left and two right STAR burners, front and rear, have flame settings even lower than the standard SIM settings.

Fig. 12 shows that the control knob has an additional range between the SIM and XLO settings. When the knob is set within this range, the flame cycles off and on. By varying the length of time the flame is off and on, the heat is reduced even further to cook delicate foods. For example, these very low settings are suitable for simmering and poaching, melting chocolate and butter, holding cooked foods at temperatures without scorching or burning, etc.

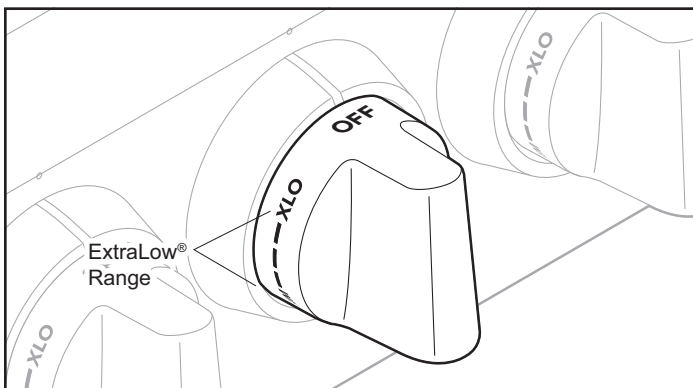

Figure 12: ExtraLow STAR Burner Control Knob

Operation of the ExtraLow® STAR® Burner

- XLO, the very lowest setting, is achieved by cycling the flame ON for approximately 7 seconds and OFF for 53 seconds of each minute.
- When the knob is rotated just beyond the SIM setting, the flame will cycle ON for approximately 54 seconds and OFF for 6 seconds of each minute.
- To vary the amount of low heat, the control can be set anywhere within the SIM and XLO range marked on the knob.

ExtraLow® Techniques

- The type and quantity of food affects which setting to use.
- The pan selected affects the setting. Its size, type, material, and whether a lid is used, all affect the consistency of the cooking temperature.
- To maintain a low or simmer heat, bring food to a rolling boil. Stir well, then cover the pan and lower the heat to a setting just below SIM.
- Check periodically to see if the control knob should be turned to another setting.
- If an over-size pan is used, the simmer action may occur mainly in the center of the pan. To equalize the temperature throughout the food, stir the food around the outer edges of the pan into the food in the center.
- It is normal to stir food occasionally while simmering. This is especially important when simmering for several hours, such as for a homemade spaghetti sauce or beans.
- When lowering the flame setting, adjust it in small steps.
- If the setting is too low to hold a simmer, bring the food back to a boil before re-setting to a higher heat.
- It is normal not to see simmer bubbles immediately after the food has been stirred.
- There may be bubbling when the flame cycles ON and no bubbles when the flame is OFF. Even when the flame is OFF, there will be steam and a slight quiver on the liquid's surface.

POWERBOOST®

The POWERBOOST, or XHI, is located at the right-front position of the rangetop. The XHI is 4,000 BTU greater (natural gas 22,000 BTU) on its highest setting than any other STAR burner. It offers the convenience to quickly boil water, sear steaks, stir-fry vegetables, etc. Use of the SIM and XLO remains the same as the other XLO burners.

STAR® Burner Cap Placement

The STAR burner caps must be properly placed on the burner bases for the cooktop to function properly. If the burner cap is not properly placed, one or more of the following problems may occur:

- Burner flames are too high.
- Flames shoot out of burners.
- Burners do not ignite.
- Burner flames light unevenly.
- Burner emits gas odor



WARNING:

To prevent flare-ups and avoid the creation of harmful by-products, do not use the cooktop without all STAR burner caps and all burner grates properly positioned.



WARNING:

To prevent burns, **DO NOT** touch STAR burner caps or grates while hot. Turn the cooktop off and allow the burners to cool.

Checking Burner Cap Placement

- Check each STAR burner to make sure there is no gap between the burner cap and burner base. See *Figures 13 and 14 : Correct and Incorrect STAR Burner Cap Placement* to see examples of correct and incorrect placements of the burner cap.
- You may gently try to move the burner caps from side to side to check if the caps are properly placed on the burner bases. When properly placed, each burner cap will rest flat on top of its burner base, and completely cover the star-shape of the burner base when viewed from the top as shown below.

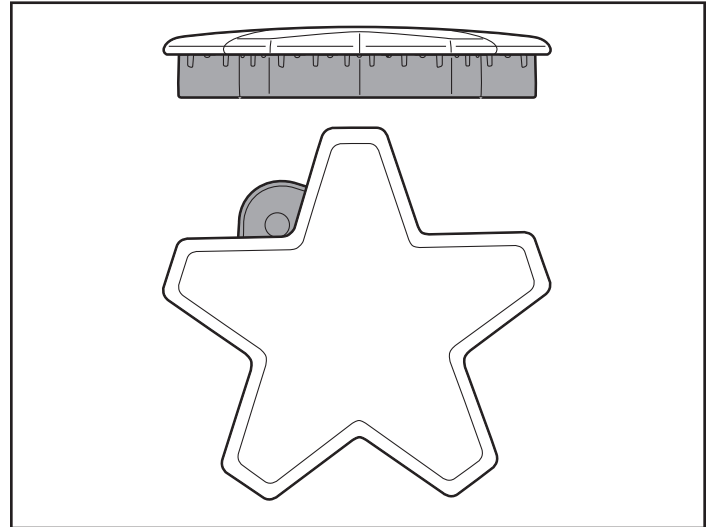

Figure 13: Correct STAR Burner Cap Placement

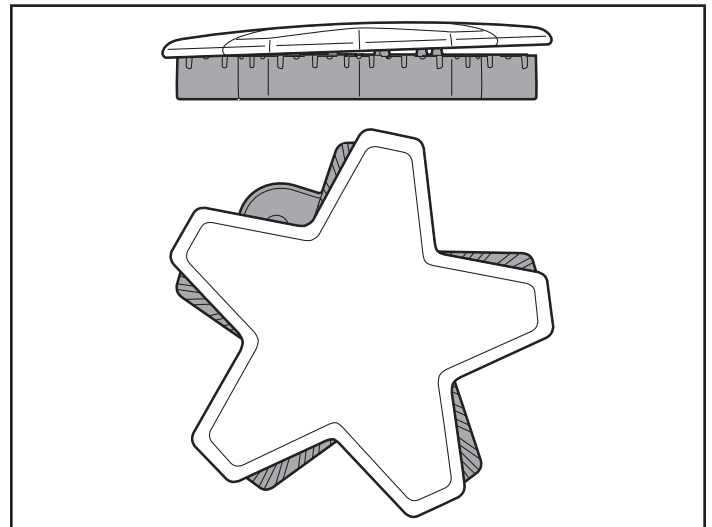

Figure 14: Incorrect STAR Burner Cap Placement

Electronic Single Point Ignition

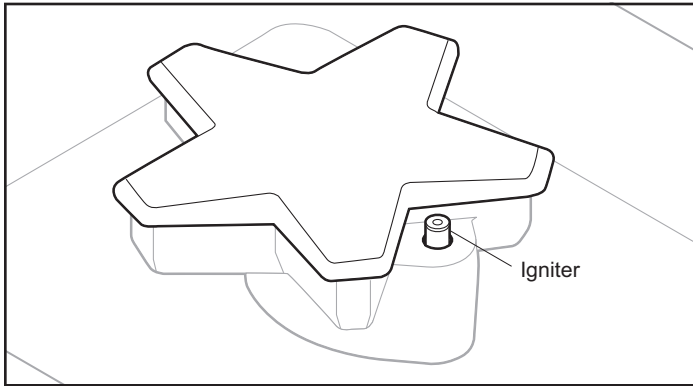

Figure 8: Igniter

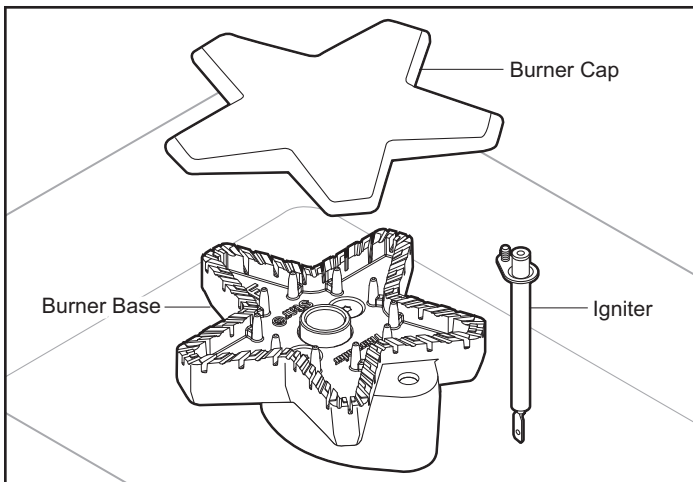

Figure 9: STAR Burner Components

Each STAR[®] burner has its own electronic igniter that sparks when the burner is turned on. Each burner should light in 4 seconds or less. If a burner does not light, check to see that the burner cap is positioned correctly on the base.



CAUTION:

DO NOT touch the STAR burners when the igniters are sparking.

If a STAR burner fails to ignite, refer to “Before Calling For Service” on page 88.

Automatic Re-Ignition

If any one or more STAR burners blow out, the electronic igniter automatically activates to re-light the flame. **DO NOT** touch the burners when the igniters are active.

IMPORTANT:

- For proper combustion, **DO NOT** use the cooktop without the burner grates in place.
- There is a slight sound associated with gas combustion and ignition. This is normal.
- On cooktops using propane (LP) gas, a slight “pop” sound may be heard from the burner ports a few seconds after the burner has been turned off.

Power Failure

- In the event of a power failure, only the burners without ExtraLow[®] can be manually lit. It is necessary to light each one individually.
- If the cooktop is being used when the power failure occurs, turn all knobs to the OFF position.
- The Standard burners can be lit by holding a match at the ports and turning the control knob to the HI position. Wait until the flame is burning all around the burner cap before adjusting the flame to the desired level.
- The ExtraLow burners **CANNOT** be used during a power failure. Be sure to turn them off.
- If either ExtraLow burner is on when a power failure occurs, they cannot be turned back on until both knobs are first turned to the OFF position.
- The griddle or grill accessory cannot be used during a power failure.
- If you smell gas, refer to safety precautions listed on page 3.



WARNING:

In the event of a power failure, turn all knobs to the OFF Position. Only the Standard burners can be lit manually.

Flame Height

- The correct flame height depends on 1) size and material of pan being used; 2) food being cooked; and 3) amount of liquid in the pan.
- **NEVER** extend the flame beyond the base of the pan.
- Use a low or medium flame for pan materials that conduct the heat slowly, such as porcelain coated steel or glass-ceramic.

Flame Description

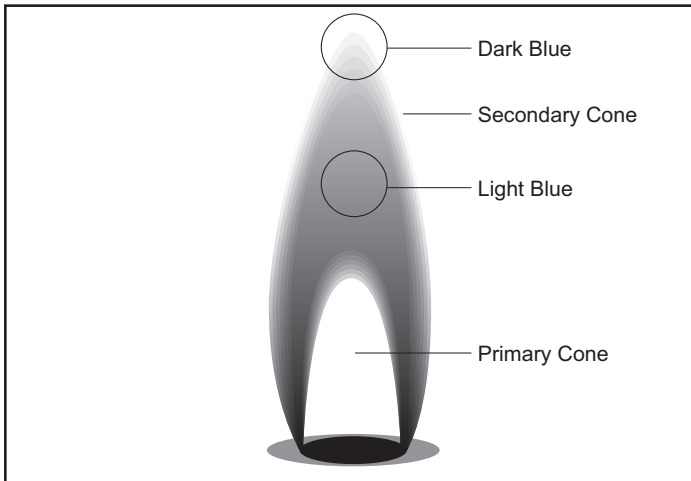

Figure 10: Flame Colors

- The STAR® burner flame color should be blue with no yellow on the tips. It is common to see orange in the flame color; this indicates the burning of airborne impurities and will disappear with use.
- With propane (LP) gas, slight yellow tips on the primary cone are normal.
- The flame should burn completely around the STAR burner cap. If it doesn't, check that the cap is positioned correctly on the base and that the ports are not blocked.
- The flame should be stable with no excessive noise or fluttering.



WARNING:

This product contains or, through ordinary use for its intended purpose, facilitates emission of chemicals or other substances known to the State of California to cause cancer and/or birth defects or other reproductive harm. To minimize exposure to these chemicals:

- 1) The STAR burners should be adjusted by a certified installer or agency to ensure proper combustion.
- 2) Ensure proper ventilation with an open window or use a ventilation fan or hood when cooking with Gas.
- 3) **ALWAYS** operate the unit according to the instructions in this manual.

Cookware Recommendations



WARNING:

To avoid risk of serious injury, damage to appliance or cookware, please observe the following:

- Bakeware, such as large casserole pans, cookie sheets, etc. should **NEVER** be used on the cooktop.
- Placement of large stock pots should be staggered when used on the cooktop.

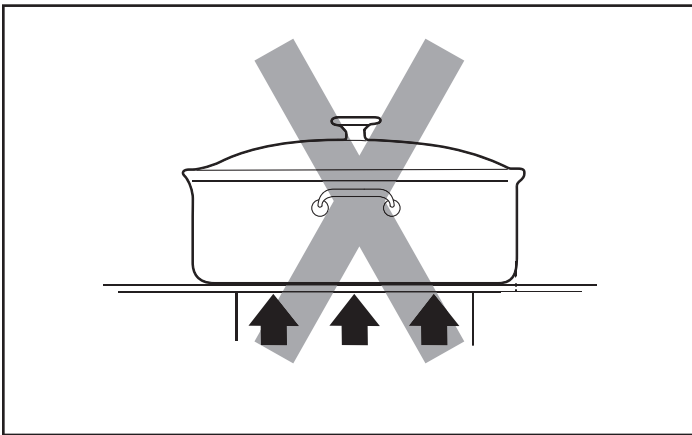

Figure 11: Base Diameter

- Select the base diameter to match the diameter of the flame. The diameter of the flame should be the same size as the pan base or slightly smaller. Oversize or undersize pans sacrifice cooking performance. A 5½" (140 mm) base size is generally the smallest recommended.

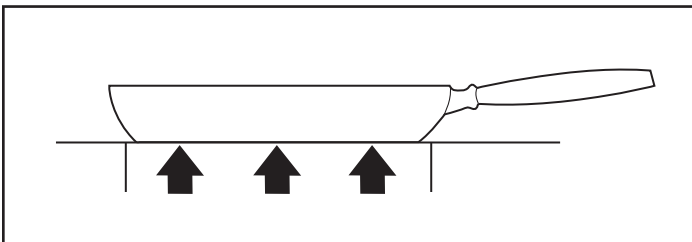

Figure 12: Balanced Pan

- Balance is important for stability and even cooking. The handle must not be heavier than the pan and tilt it unevenly. A pan must sit level on the grate without rocking or wobbling.
- Food packaged in aluminum foil should not be placed directly on the STAR® burner grate. Aluminum foil can melt during cooking.
- **DO NOT** let plastic, paper, or cloth come in contact with a hot STAR burner grate. They may melt or catch fire.

- **NEVER** let a pan boil dry. This can damage your pan and the cooking surface.
- Professional quality pans with metal handles are recommended because plastic handles can melt or blister if the flame extends up the side of the pan. Professional quality pans are found at restaurant supply stores and gourmet specialty shops. All cookware should have these characteristics: good heat conductivity, good balance, correctly sized base diameter, a heavy, flat base, and a proper fitting lid.
- For best cooking results, the flame should be contained under the bottom of the pan.
- Aluminum and copper are pan materials that conduct the heat quickly and evenly. These metals are sometimes attached to the base or in the core between stainless steel.

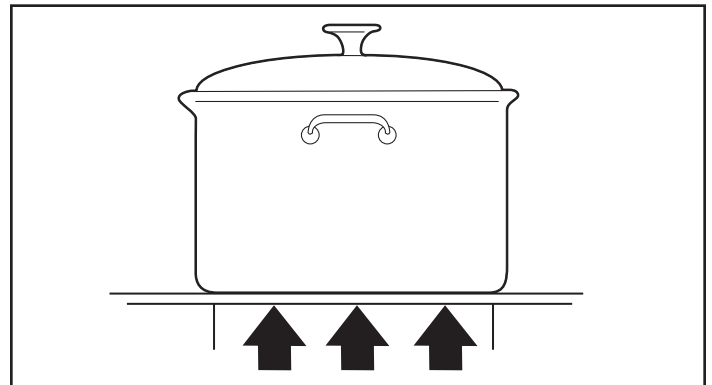

Figure 13: Flat Base Pan

- A heavy, flat base is more apt to remain flat when heated. Pan bases that are warped, dented, ridged or too lightweight will heat unevenly. Heat and cool pans gradually to avoid sudden temperature changes which tend to distort cookware. **DO NOT** add cold water to a hot pan.
- A properly fitting lid will shorten cooking time and make it possible to use lower heat settings.

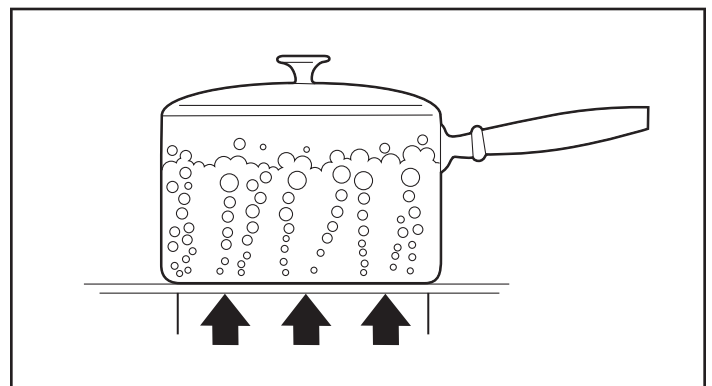

Figure 14: Covered Pan

Specialty Cookware

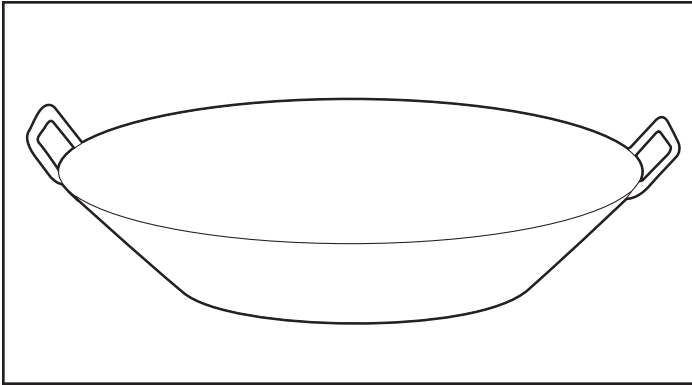

Figure 15: Flat-bottom Wok Pan

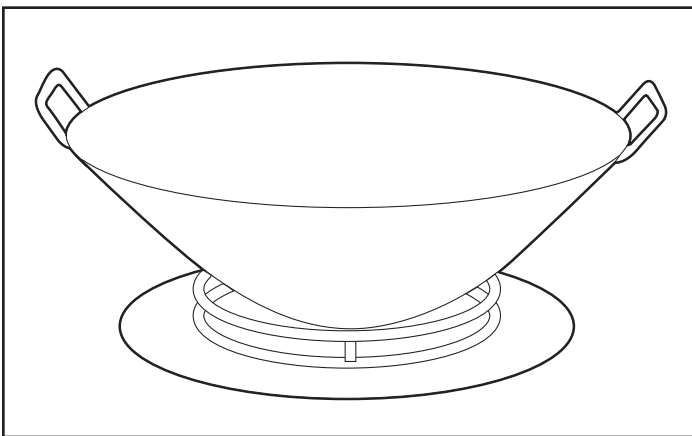

Figure 16: Round-bottom Wok Support Ring

- **Woks** — Either flat-based or round-bottom woks with the accessory ring can be used on all models. Round bottom woks must be used with a support ring. The porcelain-coated cast iron wok support ring must be purchased separately (PWOKRINGHC).
- **Canners and Stock Pots** — Select one with a base diameter that extends no more than 2" (51 mm) beyond the grate.

Standard Size Water Bath Canner

21 – 22 quarts (20 – 21 liters), with an 11" – 12" (280 – 305 mm) base and a 9" – 11" (229 – 279 mm) depth.

Standard Size Pressure Canner

8 – 22 quarts (7.5 – 21 liters), with an 8" – 11" (200 – 250 mm) base and a 6½" – 12" (165 – 305mm) depth.

Canning Tips:

- A flat base pan is preferred to one with a concave, convex, or rippled base.
- When using two canners at the same time, use staggered STAR® burners. **DO NOT** block air to the STAR burners. A flame needs the right amount of air for complete combustion.
- Use a cover on a canner when bringing the contents to a boil.
- Once the contents have reached a boil on HI, use the lowest flame possible to maintain the boil or pressure.
- Canning produces a large amount of steam. Take precautions to prevent burns.

Surface STAR[®] Burner Cooking Guide

Use the following chart guide. The settings you use will vary depending on the pans selected and the starting temperature of the food. On the chart, the “Finish Setting” has been separated for the Standard and ExtraLow[®] STAR burners. There may or may not be a change between the two STAR burner settings. The ExtraLow setting can be either a cooking or a holding setting. Raise or lower the flame setting gradually. Allow time for the pan and the food to adjust to the new setting.

Food	Start Setting	Finish Setting Standard STAR [®] Burners	Finish Setting ExtraLow [®] (XLO [®]) STAR [®] Burners
BEVERAGES Cocoa	MED – heat milk, cover	SIM – finish heating	XLO – keep warm, cover*
BREADS French Toast, Pancakes, Grilled Sandwiches	MED – preheat skillet	SIM to MED – cook	Same as for Standard STAR Burners
BUTTER Melting	SIM – to start melting		Allow 5 – 10 minutes to melt
CEREALS Cornmeal, Grits, Oatmeal	HI – cover, bring water to a boil, add cereal	SIM to MED – finish cooking according to package directions	Same as for Standard STAR Burners XLO – to hold, cover*
CHOCOLATE Melting	XLO – may be stirred to hasten melting		XLO – allow 10 – 15 minutes to melt XLO – to hold*
DESSERTS Candy	SIM to MED – cook following recipe	SIM to MED	Same as for Standard STAR Burners
Pudding and Pie Filling Mix	SIM to MED SIM – cook according to package directions	SIM	Same as for Standard STAR Burners
Pudding	SIM to MED SIM – bring milk to a boil	SIM	Same as for Standard STAR Burners
EGGS Cooked in Shell	MED HI – cover eggs with water, add lid, bring to boil		XLO – cook 3 – 4 minutes for soft cooked; or 15 – 20 minutes for hard cooked
Fried, Scrambled	SIM to MED – melt butter, add eggs	SIM finish cooking	Same as for Standard STAR Burners XLO – to hold for a short period*
Poached	HI – bring water to the boiling point, add eggs	SIM to MED – finish heating	Same as for Standard STAR Burners
MEAT, FISH, POULTRY Bacon, Sausage Patties	MED HI – until meat starts to sizzle	SIM to MED – finish cooking	Same as for Standard STAR Burners
Braising: Swiss Steak, Pot Roast, Stew Meat	MED HI – melt fat, then brown on MED HI , add liquid, cover		XLO – Simmer until tender
Quick Frying: Breakfast Steaks	MED HI – preheat skillet	MED HI – fry quickly	Same as for Standard STAR Burners

* These foods should be stirred occasionally.

Food	Start Setting	Finish Setting Standard STAR® Burners	Finish Setting ExtraLow® (XLO®) STAR® Burners
Frying: Chicken	MED HI – heat oil, then brown on MED	SIM – cover, finish cooking	Same as for Standard STAR Burners
Deep Frying: Shrimp	MED HI – heat oil	MED to MED HI – to maintain temperature	Same as for Standard STAR Burners
Pan Frying: Lamb Chops, Thin Steaks, Hamburgers, Link Sausage	MED HI – preheat skillet	MED – brown meat	Same as for Standard STAR Burners XLO – to hold
Poaching: Chicken, whole or pieces, Fish	MED HI – Cover, bring liquids to a boil		To finish cooking
Simmering: Stewed Chicken, Corned Beef, Tongue, etc.	HI – cover, bring liquid to a boil		XLO – to simmer slowly XLO – to hold, cover
PASTAS Macaroni, Noodles, Spaghetti	HI – bring water to a boil, add pasta	MED HI to HI – to maintain a rolling boil	Same as for Standard STAR Burners
POPCORN (use a heavy, flat bottom pan)	HI – cover, heat until kernels start to pop	MED HI – finish popping	Same as for Standard STAR Burners
PRESSURE COOKER Meat	MED HI to HI – build up pressure	SIM to MED – maintain pressure	Same as for Standard STAR Burners
Vegetables	HI – build up pressure	SIM to MED – maintain pressure	Same as for Standard STAR Burners
RICE	HI – cover, bring water and rice to a boil	SIM – to maintain Low Boil Cover and cook until water is absorbed	Same as for Standard STAR Burners XLO – to hold, cover
SAUCES Tomato Base	MED HI – cook meat/vegetables, follow recipe	SIM – to maintain simmer	XLO – simmer to thicken sauce, uncovered
White, Cream, Bernaise,	MED – melt fat, follow recipe	SIM – finish cooking	XLO – to hold, cover*
Hollandaise	XLO		XLO – to hold, lowest setting for short period, stir frequently
SOUPS, STOCK	HI – cover, bring liquid to a boil	SIM to maintain simmer	Simmer XLO – to hold, cover*
VEGETABLES Fresh	HI – cover, bring water and vegetables to a boil	SIM to MED – cook 10 minutes, or until tender	Same as for Standard STAR Burners XLO – to hold, cover
Frozen	HI – cover, bring water and vegetables to a boil	SIM to MED – cook according to package directions	Same as for Standard STAR Burners
Deep Frying	HI – heat oil	MED to MED HI – maintain frying temperature	Same as for Standard STAR Burners

* These foods should be stirred occasionally.

Food	Start Setting	Finish Setting Standard STAR® Burners	Finish Setting ExtraLow® (XLO®) STAR® Burners
In Pouch	HI – bring water and pouch to a boil	SIM to MED – cook according to package directions	Same as for Standard STAR Burners
Saute	HI – heat oil or melt butter, add vegetables	SIM to MED – cook to desired doneness	Same as for Standard STAR Burners
Stir Fry	HI – heat oil, add vegetables	HI to MED HI – finish cooking	Same as for Standard STAR Burners

* These foods should be stirred occasionally.

Using the Electric Griddle

Description

The built-in griddle is made of restaurant-quality aluminum that has a non-stick titanium coating. This produces a surface with even heat that is easy to clean.

A maple cutting board (PA12CHPBLK), stainless steel cover (PA12CVRJ), or titanium-coated aluminum grill plate (PA12GRILHC) are available as accessories and are purchased separately. The maple cutting board and stainless steel cover are sized to fit on top of the surface when the griddle is not being used. The titanium coated-aluminum grill plate accessory is designed to replace the griddle plate. See the instructions that come with the grill plate accessory for more details.

The maple cutting board and stainless steel cover must be removed before turning the griddle on.

- The electric griddle element is rated 120 volts AC, 1,630 watts.



WARNING:

To avoid risk of injury, **NEVER** operate griddle without the griddle plate installed. **NEVER** use griddle in a manner that is not prescribed by the Use and Care Manual.



CAUTION:

The griddle element is hot after use. Allow sufficient time for griddle components to cool before cleaning.

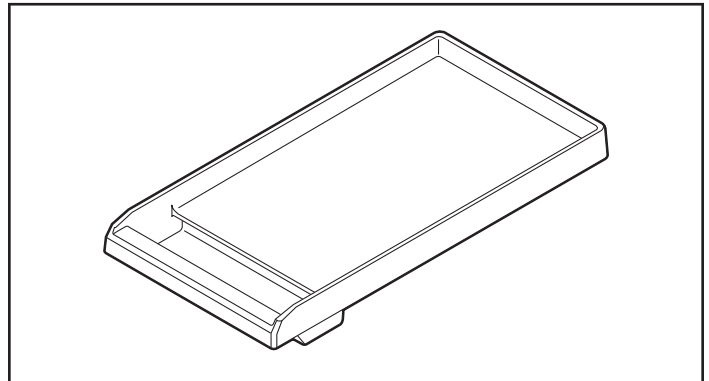

Figure 17: Griddle Plate

The griddle plate (or grill plate accessory) must always be in place when the griddle is turned on.

Control Knob

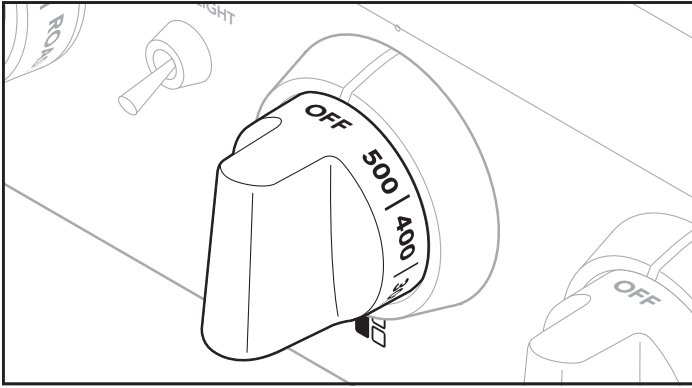

Figure 18: Control Knob

- The griddle is electronically controlled with temperatures marked on the knob from 150° – 500°F (65° – 260°C).
- There are no fixed settings on the knob.
- Press and turn the knob clockwise to the temperature setting.

Preparing the Griddle

The griddle must be tilted slightly forward for optimum performance. The griddle plate is tilted slightly from the factory; however, during installation, the installer is responsible for leveling the product. See *Installation Manual* for procedure to check and adjust griddle for proper tilt of griddle plate.

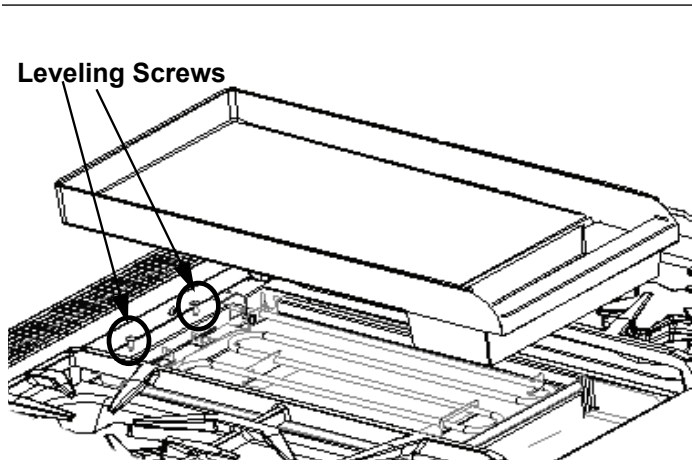

Figure 19: Griddle Leveling Screws

The griddle plate should be washed with warm soapy water, then rinsed with clear water prior to use. The griddle may be used without any butter, margarine, or oil. However, a very small amount may be used to flavor foods.

Any utensil may be used on the griddle surface. Care should be taken that the surface is not gouged when utensils are used.

Do not cut directly on the griddle plate.

NOTICE:

Griddle/grill performance may vary if there is an excessive amount of airflow in the vicinity of the appliance. The excessive airflow could be from an air-conditioning register or ceiling fan blowing at the cooktop. This could create longer than normal heat-up time, or it could cause the griddle/grill temperature to be higher or lower than the knob setting.

Note:

Having a properly installed ventilation hood is not considered a source of excessive airflow.

Griddle Cooking Guide

FOOD	SETTING
Eggs	325°F – 350°F (160°C – 180°C)
Bacon, Breakfast Sausage	375°F – 400°F (190°C – 200°C)
Toasted Sandwiches	350°F – 375°F (180°C – 190°C)
Boneless Chicken Breasts	375°F – 400°F (190°C – 200°C)
Boneless Pork Chops, 1" (25.4 mm) thick	375°F – 400°F (190°C – 200°C)
Steaks, 1" (25.4 mm) thick	400°F – 425°F (200°C – 220°C)
Ground Beef Patties, 6 ounces	375°F – 400°F (190°C – 200°C)
Hot Dogs	350°F – 375°F (180°C – 190°C)
Ham Slices, 1/2" (12.7 mm) thick	350°F – 375°F (180°C – 190°C)
Pancakes, French Toast	400°F – 425°F (200°C – 220°C)
Potatoes, Hash Browns	375°F – 400°F (190°C – 200°C)

Griddle Grease Tray

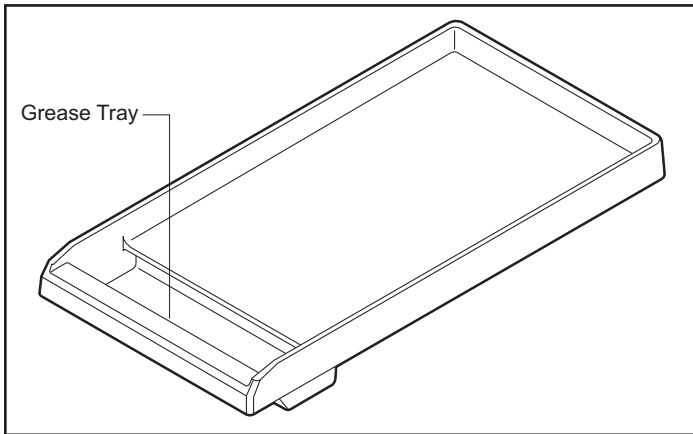

Figure 20: Grease Tray

Clean the tray after every use. When removing the tray, use care when tipping it so that the contents do not spill. The griddle plate and its grease trough are dishwasher safe.

After cooling, pour the grease into a grease-resistant container for disposal.

Cooking on the Griddle

1. Turn the knob to the appropriate cooking temperature to preheat the griddle.
2. Preheat until the griddle light goes off.
3. Add butter, margarine, oil or shortening if desired.

Using the Convection Oven



Extended Cooking Functions

Oven Controls

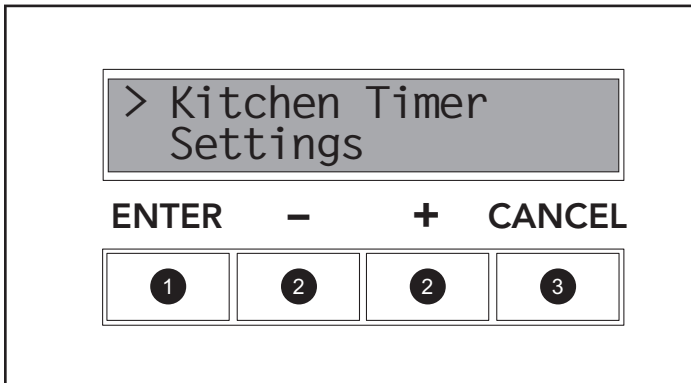

Figure 21: Oven Controls

1. **ENTER** verifies a selection
2. (-) decreases and (+) increases time and/or temperatures, it is also used to scroll through oven display functions: *Kitchen Timer*, *Cook Timer*, *Offset*, and *Sabbath*.
3. **CANCEL** clears all oven operations.

Kitchen Timer

The kitchen timer can be set for up to *12 hours*. The kitchen timer can be used whether the oven is in operation or not.

Note:

The steam oven kitchen timer can only be used when the steam oven is off.

Cook Timer

The Cook Timer is intended to mechanically shut the oven off when the desired cooking time is complete. The Cook Timer function is available for all of the primary cooking modes except for Self-Clean mode.

- Cook Time cannot be used if a temperature probe is in use.
- The maximum Cook Time setting is 12 hours.
- Using the Cook Timer is not recommended for baked goods, cakes, cookies, breads, etc. that require preheating the oven.

Programming the Meat Probe

Using the meat probe allows you more control over how your foods are cooked by automatically disabling the specified cooking mode when a dish's desired temperature, defined by the cook, has been reached.

1. Flip the cap of the outlet up (see Figure 3 on Page 14).

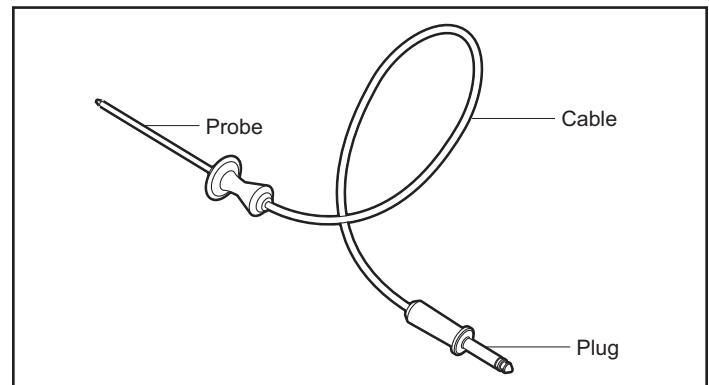

Figure 22: Meat Probe

2. Insert the plug end into the outlet (see Figure 22).
3. Insert probe into the meat.
 - To avoid damaging the probe, ensure that the meat is fully defrosted before inserting the probe.
 - Insert the probe until its tip is rested in the center of the thickest, meatiest portion of the meat.
 - Ensure that the probe does not touch bone, fat, or gristle.
 - The probe should not touch any part of the cooking dish or parts of the oven, as this will affect the accuracy of the results.
4. Close the oven door.
5. Select (-) to decrease or (+) to increase the desired internal temperature to be met. Press Enter.
6. Select the desired *cooking mode* and *oven temperature* using the knobs on the control panel.
 - The probe function is only available for *Bake*, *Convection Bake*, *Roast*, and *Convection Roast* modes.
 - Probe is not available when Cook Timer has been set.
 - The range for the probe temperature is between 120°F (50°C) and 200°F (95°C).
7. When the actual probe temperature reaches the desired set temperature, the cooking mode will be finished and the "end of cook timer" will beep to indicate that the cooking process has concluded. The oven turns itself off automatically when the meat probe temperature has been reached.

Probe Care and Use

- To avoid damaging your probe, **DO NOT** pull on the cable when trying to remove it from a dish.
- **DO NOT** use tongs or other instruments to pry on the probe when removing it or to “hammer” the probe into a food dish.
- **DO NOT** wash the probe in the dishwasher; use warm, soapy water instead to clean it.
- To prevent possible burns, wait until the oven has cooled before trying to remove the probe from the outlet.
- **DO NOT** store the probe inside the oven.
- The oven must be turned off in order to set an offset value.
- The Offset feature is available for all modes except Self-Clean.
- By default, the temperature is set at 0°.
- The unit will continue to run the input offset value indefinitely until the user manually changes it, or until the unit loses power, in which case Offset will need to be reset.

Minimum Internal Cooking Temperatures

The minimum internal temperatures that foods must reach to be considered safe to eat, as determined by the *U. S Department of Agriculture Food Safety and Inspection Service*, are as follows:

Fresh ground beef, veal, lamb, pork	160°F (72°C)
Beef, veal, lamb roasts, steaks, chops	
Medium rare	145°F (63°C)
Medium	160°F (71°C)
Well done	170°F (77°C)
Fresh pork roasts, steaks, chops	
Medium	160°F (72°C)
Well done	170°F (77°C)
Ham	
Cook before eating	160°F (72°C)
Fully cooked, to reheat	140°F (60°C)
Poultry	
Ground chicken, turkey	165°F (74°C)
Whole chicken, turkey	180°F (82°C)
Breasts, roasts	170°F (77°C)
Thighs and wings	180°F (82°C)
Stuffing (cooked alone or in bird)	165°F (74°C)
Egg dishes, casseroles	160°F (72°C)
Leftovers	165°F (74°C)

Using the Offset Feature

The Offset feature allows the cook to further fine-tune their cooking parameters to their own personal optimal settings by allowing them to adjust the temperature offset of the oven by +/-25°F (14°C) in increments of 5°F. For example, if the cook judges the oven temperature as too hot and wants to lower it by 5°F, press the “-” button. To increase the temperature by 5°F, press the “+”. This feature is useful if you find that food is consistently either too brown or too light for your tastes.

Using the Sabbath Mode

Sabbath Mode is for faiths with “No Work” requirements on the Sabbath. It keeps an oven on at a specified temperature for as long as it is required. The cook can prepare a meal prior to a holiday and then leave it in the always-warm oven until it is ready to be eaten.

- The oven lamp is disabled in Sabbath mode to prevent any action from occurring at any time the door is opened.
- The full range of bake temperatures are available in Sabbath Mode.
- The warming drawer, steam oven, gas burners and griddle on the cooktop are still fully functional during Sabbath Mode.
- Sabbath Mode is only available when the range is not already in another active cooking mode or Self-Clean.
- If the door is opened during preheat or during a cycle operation, there will be no change to the current state of the oven. That is to say, if the bake element was on before the door was opened, the element will remain on. If the element was cycled off just before the door was opened, it will remain off even though it would normally cycle back on with the call for heat. The regular cycle will resume once the door is closed.

To set Sabbath Mode:

1. Place prepared food in oven.
2. Using the “+” or “-” buttons, select SABBATH.
3. Use the “+” or “-” buttons to select one of three duration times: 26 hours, 50 hours, or 74 hours. Press **ENTER**.
4. The display will prompt the user to set BAKE and TEMP.
5. When the timer reaches “0:00”, the cooking mode will be finished and the display will beep. The oven will automatically turn off when the specified cooking time is complete.

Oven Functions

Tips for Bake Mode

Preheating the Oven

Most cooking times in recipes are worked out for a preheated oven and require that the oven already be at a certain temperature before cooking starts. Refer to your recipe for preheating recommendations. Preheating time depends on the temperature setting and the number of racks in the oven.

Getting the Best Results

- Minimize opening the door:
 - Use the built-in timer.
 - Use the interior oven light.
- Use the bakeware recommended in the recipe.
- Store the broiler pan(s) outside the oven. An extra pan without food, affects the browning and cooking.
- The type of pan used affects the browning:
 - For tender, golden brown crusts, use light non-stick/anodized or shiny metal pans.
 - For brown crisp crusts, use dark non-stick/anodized or dark, dull metal pans or glass bakeware. These may require lowering the bake temperature 25°F (15°C).

Bakeware Type

- Metal bakeware (with or without a non-stick finish), heat-proof glass, glass-ceramic, pottery, or other utensils are suitable for the oven.
- Suitable cookie sheets have a small lip on one side only. Heavy sheets or those with more than one side may affect the baking time.
- The 36" and 48" (914 mm and 1219 mm) ovens will hold a full-sized commercial baking sheet (18" x 26") (457 mm x 660 mm).

Bake Rack Positions

Rack level positions in the oven are numbered like an elevator. Rack level #1 is the lowest (Figure 23).

Placement

- Allow at least 1" (25.4 mm) of space between the pans and the oven walls so heat can circulate around each pan.
- Stagger bakeware so that one is not directly above another. Allow 1½" (38 mm) above and below each pan.

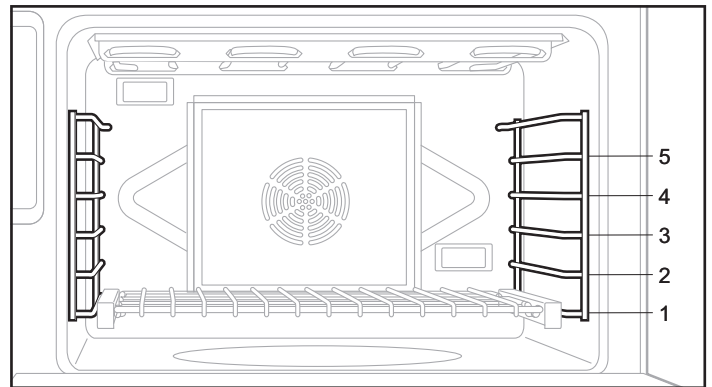

Figure 23: Main Convection Oven with Rack Positions

Main Oven

One-Rack Baking

The Bake mode is best for baking on one rack with rack level #3 used for most baked items. If the item is tall, such as an angel food cake, rack level #2 may be used. Pies are best baked on rack level #2 to make certain the bottom of the crust is done without over browning the top. When large pieces of meat or poultry are roasted, such as a prime rib of beef or a turkey, rack level #2 is the preferred rack.

Two-Rack Baking

Rack levels #2 and #4 may be used when baking on two levels. Foods such as cookies and biscuits work well using these two racks. Casserole dishes may also be baked using these two levels. The Convection Bake mode may also be used.

Three-Rack Baking

If three-rack baking is desired, the Convection Bake mode should be used.

Setting Bake & Convection Bake, Roast & Convection Roast

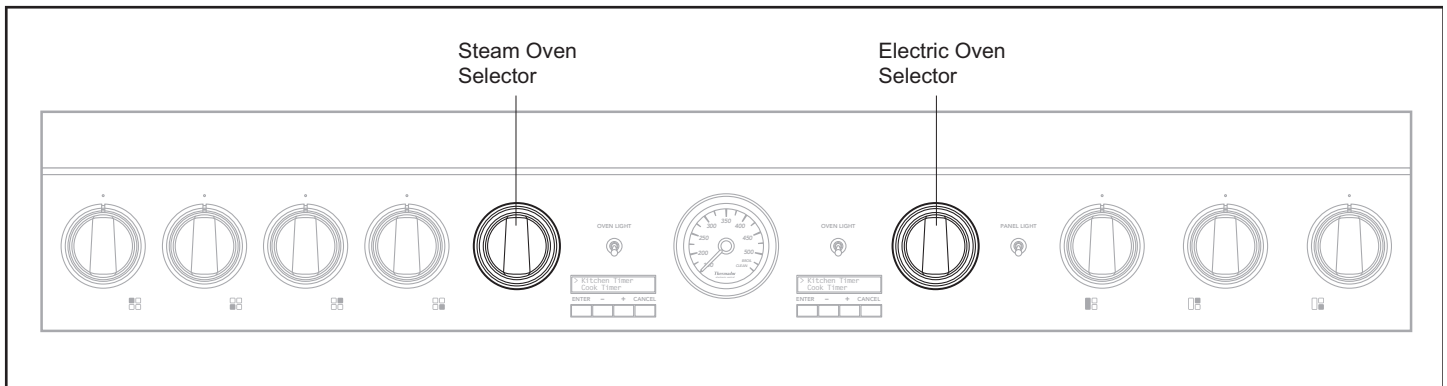

Figure 24: 48" Dual Fuel Control Panel

To Set the Oven

1. Place oven rack in desired position.
2. Set the Mode Selector Ring (which surrounds the Temperature Selector Knob) to *Bake* or *Convection Bake*, *Roast* or *Convection Roast*.
3. Place food in oven at desired rack position and shut the door.
4. Set the Temperature Selector Knob to desired temperature setting.
 - If using Convection Bake, set the Temperature Selector Knob 25°F (14°C) below the temperature suggested in the recipe. No variation in temperature setting is necessary if roasting meats or poultry.
5. After the desired mode and temperature have been set, the display will show "Preheating [] ...]" on the first line with the selected cooking mode (for example, "Bake") and the desired temperature ("350°F (180°C)").
6. The temperature gauge will start to move toward the temperature setting. The temperature gauge is a reflection of the temperature setting.
 - The needle of the temperature gauge will move to the new selected temperature setting if the temperature setting is increased or decreased. The gauge is for reference only.
 - As the oven cools down, the temperature gauge will reduce, to reflect the cooling oven temperature.

Roast

Roast has more top heat than traditional Bake. This additional top heat is for conventional open roasting when drippings are desired or for covered-dish roasting.

Roast Mode Tips

- Roast mode is excellent for less tender meats or poultry when meat is braised and a covered dish is used.
- Use a high-sided roasting pan or cover dish with a lid or foil to roast meats and vegetables.
- Add liquids, such as water, juice, wine, bouillon, or stock for flavor and moisture.
- Roasting bags are suitable to use in this mode.
- When roasting whole chickens or turkey, tuck wings behind back and loosely tie legs with kitchen string.

Roasting Recommendations				
MEAT AND POULTRY IN COVERED PAN	OVEN TEMPERATURE	RACK LEVEL	COOK TIME	END TEMP
Beef:				
Pot roast, 3 – 4 pounds	350°F (180°C)	1	40 – 60 minutes per pound	170°F (80°C)
Beef brisket	350°F (180°C)	2	50 – 60 minutes per pound	170°F (80°C)
Beef chuck	350°F (180°C)	1	45 – 55 minutes per pound	170°F (80°C)
Meatloaf	350°F (180°C)	3	60 – 90 minutes total time	170°F (80°C)
Poultry:				
Chicken, whole	375°F (190°C)	1	18 – 21 minutes per pound	180°F (80°C)
Chicken, pieces	375°F (190°C)	1	Total time 60 minutes	180°F (80°C)
Turkey, whole	325°F (165°C)	2	11 – 15 minutes per pound	180°F (80°C)
Pork:				
Shoulder	325°F (165°C)	1	35 – 40 minutes per pound	170°F (75°C)
Smoked ham, half	325°F (165°C)	1	2 – 3 hours total	170°F (75°C)

Convection

Cooking with Convection

There are many advantages to cooking with convection. In the convection system, a fan in the back of the oven moves heated air evenly around the oven. The moving air provides even heat so foods can be placed on any rack level with consistent results. Multiple racks of foods can be cooked or large quantities of foods can be cooked at the same time. Foods will cook thoroughly without having to rotate pans.

Low, shallow bakeware should be used with convection cooking. This allows the heated air to circulate around the food. Pans with high sides or pans that are covered are not suitable for convection cooking because high sides or lids prohibit the warm air from circulating around the food.

Your favorite pans and cookware can be used for convection cooking provided they have low sides to allow the heated air to circulate around the food. Any food cooked uncovered will brown evenly and form a nice crust. Foods in covered dishes (casseroles, pot roast) or delicate custards do not benefit from convection cooking.

Convection Roast

Convection roasting combines the heat from the lower concealed element with additional heat from the convection element and fan. The result is a crispier exterior that seals in the interior juices. It is perfect for roasting tender meats in an uncovered, low-sided pan.

- **DO NOT** cover meat or use cooking bags.
- Convection Roasting large cuts of meat and poultry generally takes 10 to 20% less cooking time. Check doneness early.

Convection Baking

Time can be saved by baking an entire batch of cookies at the same time. The cookies will bake evenly and be done all at once. The baking time may be shorter due to the warm circulating air. For small items such as cookies, check to see if they are done 1 – 2 minutes before the recipe time. For larger baked items such as cakes, check 5 – 6 minutes before the time indicated on the recipe.

Convection cooking of meat and poultry will result in foods that are brown and crispy on the outside and moist and juicy on the inside. Large meat or poultry items may cook up to 30 minutes less than the suggested time so check them early so they will not be over baked. Use of the built-in meat probe will provide more accurate results than the “minute per pound” method (see “Programming the Meat Probe” on page 33). The larger the piece of meat or poultry, the more time you will save.

Converting Conventional Baking to Convection Baking

To convert most recipes for baked items (cookies, cakes, pies, etc.); reduce the oven temperature by 25°F (14°C). For meats and poultry, the temperature should not be reduced. The same temperature recommended in recipes and cooking charts for meats and poultry should be used.

Tips for Convection Bake

Preheating the Oven

Preheat the oven before cooking any foods, except large pieces of meat or poultry. See your recipe for preheating recommendation. Preheating time depends on the temperature setting and the number of racks in the oven.

Temperature Setting

When using Convection Bake, reduce the temperature recommended in the recipe by 25°F (14°C), although the temperature does not need to be reduced when cooking meats and poultry. When roasting meats, check internal temperature prior to time recommended by recipe to prevent over cooking.

High Altitude Baking

When baking at high altitudes, in either Bake or Convection Bake, recipes and baking times vary. For accurate information, write the Extension Service, Colorado State University, Fort Collins, Colorado 80521. There may be a cost for the bulletins. Specify the type of information you want (example: cakes, cookies, breads, etc.).

Condensation

It is normal for a certain amount of moisture to evaporate from the food during any cooking process. The amount depends on the moisture content of the food. The moisture will condense on any surface cooler than the inside of the oven, such as the control panel.

Rack Positions (see Figure 23 on Page 35)

— One-Rack Baking

- When baking on one rack, best results are obtained in the bake mode (See “One-Rack Baking” on page 35.)
- When roasting a turkey or a large piece of meat, convection bake may be used. Rack #2 is the most appropriate rack.

— Two-Rack Baking

- Racks #2 and #4 are most appropriate when using the convection bake mode for cakes, cookies, biscuits, and other baked goods. Cake pans should be staggered on racks #2 and #4. Cookie sheets should be placed on rack #2 directly under the one on rack #4.
- To bake several casseroles, frozen pies, or cakes, use racks #2 and #4.
- These two racks can also be used for a large oven meal.

— Three-Rack Baking

- When several sheets of cookies are to be baked, bake them on racks #1, #3, and #5. Place the baking sheets directly above each other on the respective racks to allow air to flow around the baking sheets.

Bakeware Type

- Aluminum bakeware gives the best browning results.
- Cookie sheets with only one or two sides give the best results. Aluminum commercial half-sheets or professional cooking utensils may be used but baking times may be increased.

Placement

- For better browning, utensils such as cookie sheets, jelly roll pans, and rectangular baking pans should be placed crosswise on the rack with the shorter sides on the right and the left. This allows the air to circulate freely.
- When baking on more than one rack, cookie sheets should not be staggered; however, round cake pans should be staggered.



CAUTION:

When using the oven in any mode NEVER use aluminum foil to cover the oven racks or to line the oven. It can damage the oven and cause a fire hazard if heat is trapped under it. See page 6.

Convection Baking Guide

FOOD	PAN SIZE	CONTROL TEMPERATURE SETTING	TOTAL SUGGESTED COOKING TIME
Cookies	12" x 15" Cookie Sheet	375°F (190°C)	8 – 12 minutes
Layer Cakes	8" or 9" Round	350°F (180°C)	25 – 35 minutes
Sheet Cakes	9" x 13" Pan	350°F (180°C)	30 – 40 minutes
Bundt™ Cakes	12 Cup	325°F (165°C)	60 – 75 minutes
Brownies or Bar Cookies	9" x 9" Pan	325°F (165°C)	20 – 25 minutes
Biscuits	12" x 15" Cookie Sheet	425°F (220°C) or Package Directions	10 – 15 minutes
Quick Bread	8" x 4" Loaf Pan	350°F (180°C)	55 – 70 minutes
Muffins	12-cup Muffin Pan	425°F (220°C)	14 – 19 minutes
Fruit Pies	9" Diameter	425°F (220°C)	35 – 45 minutes
Fruit Cobblers	9" x 9" Pan	400°F (205°C)	25 – 30 minutes
Yeast Bread, Loaves	8" x 4" Loaf Pan	350°F (180°C)	25 – 30 minutes
Dinner Rolls	9" x 13" Pan	375°F (190°C)	12 – 18 minutes
Cinnamon Rolls	9" x 13" Pan	375°F (190°C)	25 – 30 minutes
Yeast Coffee Cake	12" x 15" Cookie Sheet	375°F (190°C)	20 – 30 minutes

Keep Warm

The Warm mode will keep hot, cooked foods at serving temperature. **ALWAYS** start with hot food. **DO NOT** use this mode to heat cold food other than for crisping crackers, chips and dry cereal. Serving dishes, plates and cups may be kept warm with this mode. **DO NOT** use the WARM mode to cook food.



WARNING:

Food Safety Concern Food Poisoning Possible — DO NOT use the Warming Mode for cooking food. The warming oven mode is not hot enough to cook foods at safe temperatures.

- When keeping cooked food warm, allow time for the oven to preheat before placing the item in the oven.
 - Warm mode temperatures range from 140° – 150°F (60 – 65°C)
 - Food should be at serving temperature, above 140°F (60°C), before being placed in the oven.

- Place warmed dish in the oven. Close the door.
 - DO NOT** open the oven door unnecessarily. Opening the door will reduce the temperature of the oven.
- Select Warm using Selector Knob. **DO NOT** turn on Oven Temperature Control Knob.
 - Food may be kept hot in its cooking container or transferred to a heat-safe serving dish.
 - Aluminum foil may be used to cover food.
 - Use only heat-safe dishes.



CAUTION:

Plastic containers or plastic wrap can melt if in direct contact with the oven walls or oven bottom.

Automatic operation of the cooling blower

The cooling blower does not activate in any of the BAKE modes for temperature settings less than 300°F (150°C). For temperature settings of 300°F (150°C) or greater, the cooling blower activates only after the oven reaches 300°F (150°C), while heating up to the set temperature. When the oven is turned off, the blower remains on until the oven temperature cools to 375°F (190°C). Likewise for BROIL modes, the cooling blower activates only after the oven reaches 300°F (150°C), while heating up to broiling temperature.

Note:

This cooling process normally pushes heated air forward, through the air space above the top of the oven door.

DO NOT continue to use the oven if the cooling blower fails to activate while baking at temperature settings of 300°F (150°C) or greater, while broiling, or in CLEAN mode. Call a qualified service agency to repair the range.

Other Uses Of Bake

Slow Cooking and Low Temperature Uses of the Oven

In addition to providing perfect temperatures for baking and roasting, the oven can be used at low temperatures to keep hot, cooked foods at serving temperature and to warm plates.

Hot cooked foods can be kept at serving temperatures. Set the oven to bake and use the temperature suggested on the chart.

For best results, preheat the oven to the desired temperature.

Foods that need to be kept moist must be covered with a lid or aluminum foil.

Suggested Temperature Recommendations to Keep Food Hot

FOOD	OVEN TEMPERATURE
Beef	150°F (70°C)
Bacon	200° – 225°F (90° – 110°C)
Biscuits and Muffins (covered)	175° – 200°F (80° – 90°C)
Casserole (covered)	175° – 200°F (80° – 90°C)
Fish and Seafood	175° – 200°F (80° – 90°C)
Deep Fried Foods	200° – 225°F (90 – 110°C)
Gravy or Cream Sauces (covered)	175°F (80°C)
Lamb and Veal Roasts	175° – 200°F (80° – 90°C)
Pancakes and Waffles (covered)	200° – 225°F (90° – 110°C)
Potatoes, Baked	200°F (90°C)
Potatoes, Mashed (covered)	175°F (80°C)
Pies and Pastries	175°F (80°C)
Pizza (covered)	225°F (110°C)
Pork	175° – 200°F (80° – 90°C)
Poultry (covered)	175° – 200°F (80° – 90°C)
Vegetables (covered)	175°F (80°C)
Warm Plates	150°F (70°C)



WARNING:

FOOD SAFETY — The United States Department of Agriculture advises: **DO NOT** hold foods at temperatures between 40°F – 140°F (4°C – 60°C) for more than 2 hours. Cooking raw foods below 275°F (135°C) is not recommended.

Broil/Convection Broil

Tips for Broil

Preheating the Broiler

It is recommended that you preheat the broil element before starting to cook. Preheat until the temperature indicator reaches BROIL.

Getting the Best Results

- Defrost food before broiling.
- Door is to be closed during broiling.
- Steaks should be more than 1" (25.4 mm) thick if rare meat is desired. Use convection broil if steaks are over 1½" (38 mm) thick.
- Turn foods over only once, after half the total cooking time. It is not necessary to turn very thin foods (ham slices, fillets of fish, etc.). Liver slices must be turned over regardless of thickness.
- Center foods directly under the broiling element for best browning.

Rack Positions

Before turning on the oven, place the rack in the desired position. After preheating the broiler, center the broil pan under the broil element (see Figure 23 on Page 35).

Rack #5 — Use this rack position when broiling beef steaks, ground meat patties, ham steak and lamb chops 1" (25.4 mm) or less in thickness. Also use when top browning foods.

Rack #4 — Use this rack position when broiling meat 1½" (29 mm) or more in thickness or fish, poultry, pork chops and ham steaks 1" (25.4 mm) or more in thickness.

Rack #3 — Use this rack when broiling chicken quarters or halves.

Utensils

- The porcelain enamel two-piece broil pan and grid is included with the range. **DO NOT** cover the slotted grid (top) with aluminum foil.
- Use metal or glass-ceramic bakeware when top browning casseroles, main dishes, or bread.
- **DO NOT** use heat-proof glass or pottery. This type of glassware cannot withstand the intense heat of the broil element.

Setting Broil or Convection Broil

Only the upper element heats in the BROIL mode. Successful broiling requires constant exposure to high, intense heat.

1. Place oven rack in desired position.
2. Set the Mode Selector Ring to BROIL or CONVECTION BROIL.
3. Set the Temperature Selector Knob to BROIL setting.
4. The temperature indicator will move to BROIL after five minutes.
5. Place food in oven at desired rack position as referenced on this page.
6. **The door should be closed throughout the broil cycle.**

Your THERMADOR® range comes with a large two-piece broiler pan. The slotted grid allows drippings to flow into the lower pan, away from the intense heat of the broil element, minimizing spattering and smoking.

Automatic operation of the cooling blower:

For either **BROIL** mode, the cooling blower activates only after the oven reaches 300°F (150°C), while heating up to the broiling temperature. When the broiler is turned off, the blower remains on until the oven temperature cools to 375°F (190°C).

DO NOT continue to use the broiler if the cooling blower fails to activate while broiling. Call a qualified service agency to repair the range.

Broiling and Roasting Guide

All meats are placed on the broiler pan included with the range.

FOOD ITEM	RACK NUMBER	OVEN MODE	CONTROL TEMPERATURE SETTING	APPROXIMATE COOKING TIME	SPECIAL INSTRUCTIONS AND TIPS
BEEF					
Ground Beef Patties, 1/2" (12.7 mm) thick	5	Broil or Conv Broil	Broil or Conv Broil	15 – 20 minutes	Broil until no pink in center
T-Bone Steak	4	Broil or Conv Broil	Broil or Conv Broil	12 – 20 minutes	Time depends on rareness of steak
Flank Steak	4	Broil or Conv Broil	Broil or Conv Broil	12 – 20 minutes	Rare to medium rare
Rib Roast	3	Roast or Conv Roast	425°F (220°C) to start 325°F (165°C) to finish	20 – 25 min/lb	Small roasts take more minutes per pound; reduce time by using Convection Roast
PORK					
Loin Roast	3	Roast or Conv Roast	325°F (165°C)	20 – 25 min/lb	Cook until juices are clear
POULTRY					
Boneless, Skinless Chicken Breasts	4	Broil or Conv Broil	Broil or Conv Broil	20 – 25 minutes	Cook until juices are clear
Chicken Thighs	3	Broil or Conv Broil	Broil or Conv Broil	25 – 30 minutes	Remove skin; Cook until juices are clear
Half Chickens	3	Broil or Conv Broil	Broil or Conv Broil	30 – 45 minutes	Turn with tongs; Cook until juices are clear
Roast Chicken	2	Roast or Conv Roast	350°F (190°C)	75 – 90 minutes	Do not stuff; reduce time by using Convection Roast
Turkey	2	Roast or Conv Roast	325°F (165°C)	20 – 25 min/lb	Reduce time by using Convection Roast

Using the Steam Convection Oven



Extended Cooking Functions

Steam Oven Modes

The steam oven in your new THERMADOR® range offers steam, convection, and modes that combine steam and convection. Using EasyCook's automatic programming, you can prepare dishes ranging from steamed vegetables to pot roast to bread.

- **STEAM:** Steaming preserves nutrients, texture and taste in vegetables, fish, and side dishes. It also allows you to efficiently extract juice from fruits.
- **TRUE CONVECTION:** Even heat distribution assures superb moist cakes, sponge cakes, and braised meat.
- **STEAM/CONVECTION:** The blend of steam and convection modes is ideal for fish, soufflés, and baked goods.
- **REHEAT:** The inflow of steam keeps the food moist and brings back the original flavor, texture, and crispness when cooked food is gently reheated.
- **PROOF:** Steam and convection modes are combined to keep the surface of rising bread dough from drying out while the dough rises much faster than at room temperature.
- **SLOW COOK:** Slow roasting of all meat cuts and types, especially roast beef and leg of lamb, keeps them tender.
- **DEFROST:** This mode defrosts food for cooking or serving.
- **EASYCOOK:** This mode allows you to automatically program the cooking of many different dishes.

Start by getting acquainted with the controls, components, and settings. Then explore the wealth of new cooking options the steam oven gives you.



CAUTION:

Use care when opening the oven door during or immediately after operation. Stand to the side of the oven when opening an oven door to allow hot air or steam to escape. Keep face well away from the open door to avoid injury.

Controls and Display Screen

Steam Oven Temperature Control Knob

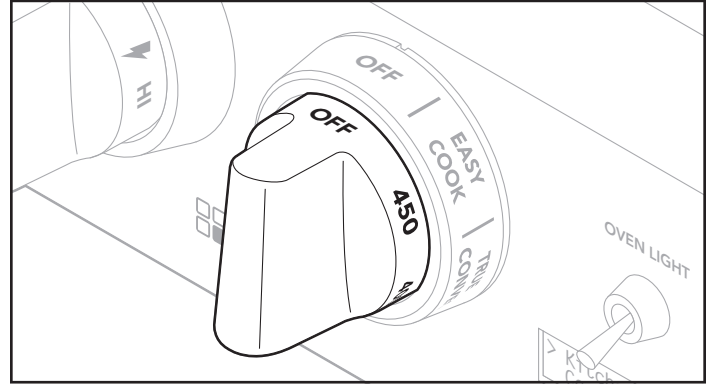

Steam Oven Mode Selector Ring

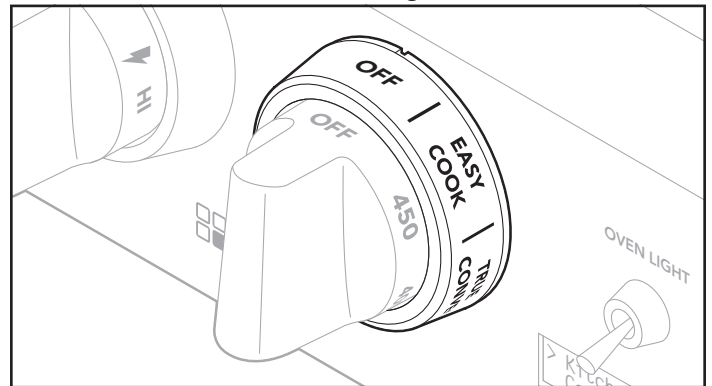

The steam oven operates with two controls:

- The unique THERMADOR combination of an inner Temperature Control Knob and an outer Mode Selector Ring allows you to choose the steam oven mode and set the temperature.
- The LCD screen with buttons below it displays the oven's status and allows you to control a large variety of oven functions and settings.

Mode Selector Ring and Temperature Control Knob

Using the Mode Selector Ring, you can select eight oven functions. The Mode Selector Ring turns in either direction from OFF, which is in the vertical position.

Steam Oven Setting	Function of Each Setting
OFF	Turns oven OFF
EASYCOOK	Sets automatic programming
TRUE CONVEC	Operates as a convection oven, with no steam
REHEAT	Gently reheats cooked foods
DEFROST	Defrosts frozen foods for cooking or serving.
SLOW COOK	Slowly roasts meats so they remain very tender
PROOF	Proof (raises) yeast dough and sourdough
STEAM/CONVEC	Combines steam and convection oven modes
STEAM	Stews vegetables, fish, and side dishes; extracts juices

Use the Temperature Control Knob to set the steam oven temperature from 100°F (40°C) – 450°F (230°C).

Note:

The Temperature Control Knob does not work with the STEAM, DEFROST, or PROOF modes because the oven is set automatically to 100°F (38°C) for STEAM, 110°F (45°C) for DEFROST, and 85°F (30°C) for PROOF.

LCD Display Screen and Buttons

Press any display key to show the options.

The available options are displayed on the screen with a “>” arrow next to function that can be selected.

Use the “+/-” buttons to scroll through modes or options, and press the “ENTER” button to select the desired option or mode.

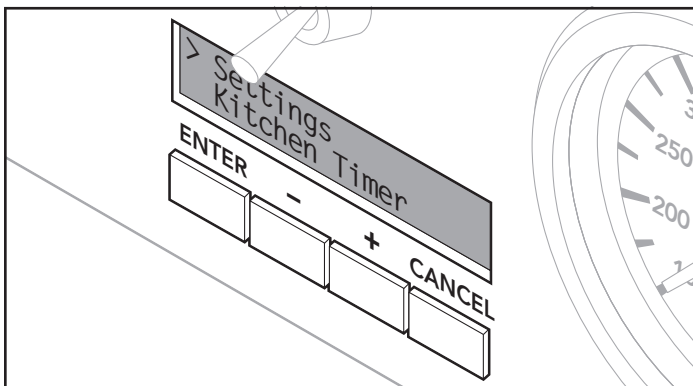

Oven Interior and Accessories

The oven has four rack levels. The rack levels are numbered bottom to top as shown in the figure below.

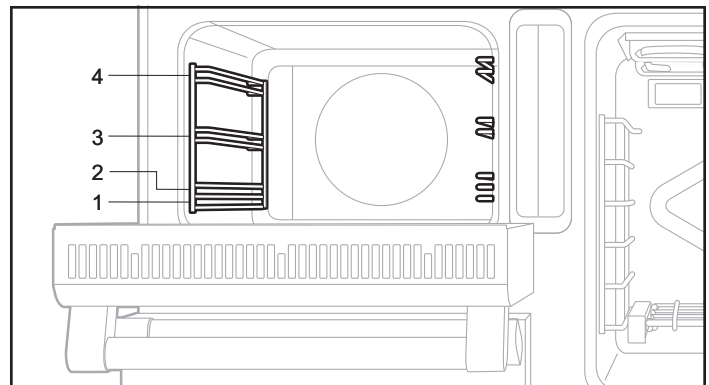

WARNING:

DO NOT use aluminum foil or protective liners to line any part of the oven, especially the cavity bottom. Using foil or liners may result in a risk of electric shock or fire.



CAUTION:

DO NOT cover the evaporator dish. **DO NOT** place ovenware on the cavity bottom.



CAUTION:

DO NOT slide any accessories in between the rack levels. The accessory may tip over.

Use only accessories that come with the range or were purchased through customer service for use in this steam oven. These accessories are designed specifically for your steam oven. You may use other ovenware appropriate for casseroles, soufflés, round cakes, and similar dishes, placing them on the wire rack (*suggestions for appropriate cookware are in the “Cooking Tables and Tips” section, starting on page 58*).

The following steam oven accessories come with your range:

Wire rack
(CSRACKH)
Use for support during baking.

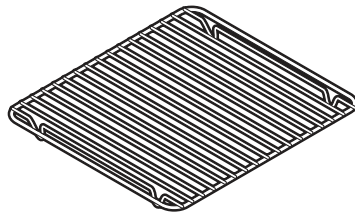

Perforated cooking pan full-size (CS2XLPH)
1 5/8" deep
Ideal for steaming fish or large quantities of vegetables, extracting juice from berries, and much more.

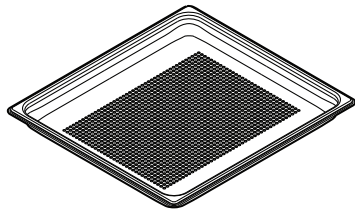

Perforated cooking pan, half-size
(CS1XLPH)
1 5/8" deep
Ideal for steaming fish or large quantities of vegetables, extracting juice from berries, and much more.

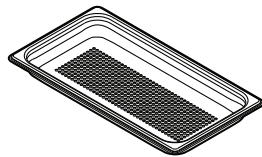

Cooking pan, half-size
(CS1XLH)
1 5/8" deep
Use for smaller quantities and for rice and cereals.

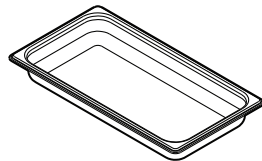

Baking pan, full-size
(CS2LH)
1 1/8" deep
Ideal for baking cakes and catching dripping liquid when steaming.

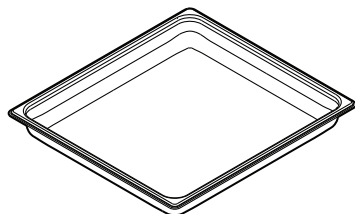

The following additional accessories can be purchased in retail appliance stores where THERMADOR® products are sold:

Accessory	Order Number
Perforated cooking pan full-size, 1 5/8" deep	CS2XLPH
Perforated cooking pan half-size, 1 5/8" deep	CS1XLPH
Cooking pan full-size, 1 5/8" deep	CS2XLH
Cooking pan half-size, 1 5/8" deep	CS1XLH
Baking pan full-size, 1 1/8" deep	CS2LH
Wire rack	CSRACKH
Descaling tablets	573828
Cleaning tablets/detergent	573829
Water hardness test strips	056317

Note:

The cooking pans may become temporarily warped during baking as a result of major temperature changes that may occur, for example, if food is placed on only one part of the pan or if a deep frozen item (like a pizza) is placed on the pan.

Water Tank

The water tank is on the right side of the steam oven. It holds 1.4 quarts (1.3 L) of water. The water tank **is not dishwasher safe**. To slide the water tank out to fill or empty it, open both the steam and the convection oven doors.

Important notes about the water used to fill the tank:

- Moisten the seal in the tank lid with some water before using it for the first time.
- Use only fresh tap water or, if necessary, plain non-carbonated purchased water to fill water tank.

 CAUTION:
NEVER fill the water tank with distilled water or liquid other than water.

- If your water is very hard (3 grains per gallon or higher), we recommend using softened water.
- If your tap water is highly chlorinated (>40 mg/L), use plain non-carbonated purchased water with a low amount of chlorine.

Water level sensor warnings:

The water tank must have enough water to generate the steam needed for the cooking mode and time you are using. As the water is converted to steam, the tank level will drop during cooking. Three different water levels are monitored by the oven:

Level No.	Display Screen Warning When Oven is Turned ON	Water Level Status	What Will Happen?
1	“Water Level Is Low” – shows until the oven is turned off.	Tank less than full but not empty (at least one-third full)	Heating mode can begin or continue if you hit ENTER when the display shows that water is low.
2	“Refill Water Tank” – shows until the oven is turned off.	Empty tank (less than one-third full)	Heating mode stops until the water tank is refilled or the oven is turned OFF. The heating element remains off until the tank is refilled and replaced in the slot. At this point, steam cooking resumes. The display shows preheating (if needed), after which the Cook Timer resumes counting down.
3	None	Full tank, any oven mode can be run	Oven can be turned on or will continue running.

Automatic calibration of the steam oven to air pressure at your location:

The temperature at which water boils depends on the air pressure, which is lower at higher elevations. The steam oven automatically calibrates to adjust to the pressure conditions in your area the first time steam is used at 212°F (100°C). More steam than usual will be produced during calibration.

Contact your water utility company to find out what type of tap water you have.

Before each use of the steam oven:

1. Fill the water tank with cold water up to the MAX mark.
 - The steam oven can operate at 100% steam for 150 minutes without the need to refill the water tank.
2. Close the tank lid until it clearly snaps into place.
3. Slide the tank all the way to the back of the slot.

After each use of the steam oven:

Empty the water tank after each use.

1. Keep the water tank level while slowly pulling it out of the slot to ensure that no remaining water drips down and out through the vent.
2. Pour out the water.
3. Thoroughly dry the seal of the tank lid and the slot where the tank resides. Prolonged dampness could lead to a musty odor in the tank.

Before Using the Oven for the First Time

Set the Water Hardness Level

1. Determine the hardness of your tap water by using test strips (not provided) or by asking your water utility company.
2. With the oven OFF, push any button to bring up two choices on the display screen, KITCHEN TIMER and SETTINGS.
3. Using the “+/-” buttons, select SETTINGS and press “ENTER”.
4. Scroll through SETTINGS until the arrow (>) points to WATER HARDNESS. Press “ENTER”.
5. Using the “+/-” buttons, scroll the number scale, and press “ENTER” when the arrow points to the hardness level for your water. The factory setting is 3.
 - 1 = Softened
 - 2 = Soft
 - 3 = Average
 - 4 = Hard
 - 5 = Very Hard

Unless you use softened water, you will need to descale your steam oven at regular intervals (see “*Descal*” in the “*Care and Maintenance*” section on page 77).

If you move or if your water source changes, you will need to reset the water hardness value.

Review Other Oven Settings

With the steam oven OFF, you can access various other oven features. Go to the SETTINGS on the initial options on the display screen and press “ENTER”. The full list of settings will display:

- Country Code
- Temperature Units
- Weight Units
- Calibration
- Water Hardness
- Descal
- Steam Clean
- Factory Reset

Many of these features should be adjusted during installation or after a move to a new location.

For more information on these initial settings, see “*Steam Oven Settings*”, page 52. Descal and steam clean are part of your routine care of the steam oven. They are described in detail in the “*Care and Maintenance*” section of this manual, starting on page 77.

Clean the Accessories

Wash the accessories thoroughly with soapy water and a cloth before using them.

Clean the Oven Using the STEAM Mode

Before using the steam oven for the first time, heat it once while it is empty:

1. Fill and slide in the water tank (see instructions under “*Water Tank*”, page 48).
2. Turn the Mode Selector Ring to STEAM. The display screen will show SELECT TEMPERATURE on first line and 210°F (100°C) on the second.
3. Press **ENTER**. The display will show “Set Cook Timer” on the first line and 0:00 on the second.
4. Using the “+/-” buttons, set the cooking time for 20 minutes (0:20, in HR/MIN format). The oven will heat for 20 minutes and then stop.
5. Leave the door cracked open until the oven cools.

This initial cleaning will also calibrate the steam oven to the air pressure at your location. Calibration produces more steam than ordinary use.

Operating Your Steam Oven

Using seven of the eight modes available in your steam oven requires similar steps. *Using EasyCook is somewhat different and is described separately starting on page 54.*

Starting the Oven

1. Place food in steam oven before preheat unless using Slow Cook or True Convection modes. In Slow Cook or True Convection modes place food in oven after steam oven has been preheated.
 - Food needs to be in the oven during preheat for steam modes because if the door is opened to put food inside after the preheat cycle then the steam will leave the cavity, lowering the temperature, which may cause the food to be undercooked.
2. Turn the Mode Selector Ring to the desired heating mode. The display will show “Select Temperature” on first line and a temperature, which will depend on the mode on the second.

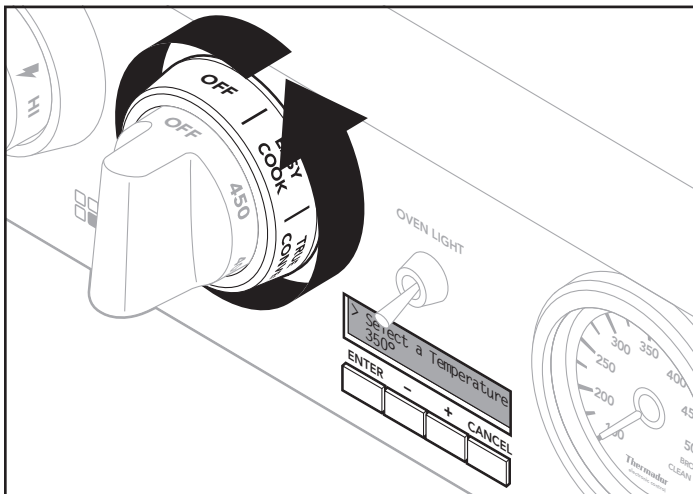

3. If temperature control is possible in the mode you choose, turn the Temperature Control Knob to the desired temperature. The desired temperature will be displayed.

Note:

Temperature control is not possible with DEFROST, PROOF, and STEAM, which have preselected cooking temperatures. When you select one of these modes, the temperature will appear on the display. Press ENTER to proceed.

4. Press **ENTER**. The display will show “Set Cook Timer” on the first line and “0:00” on the second (*see page 53 for full timer details*).
5. Using the “+/-” buttons, select the desired cooking time.

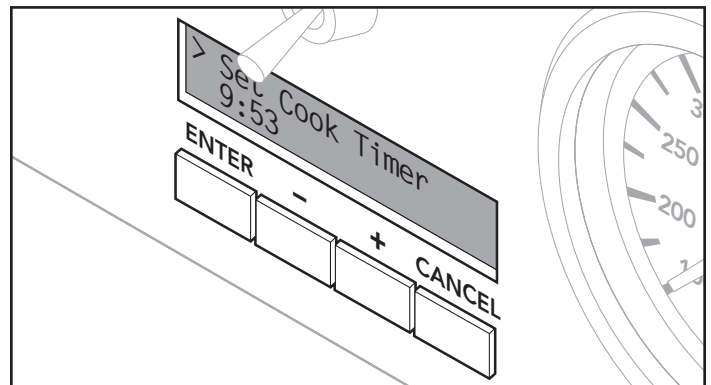

6. Once you have set the desired time, press **ENTER**. The oven will begin preheating. The display will show the “Preheating” phase from one bar through four. At four bars the set temperature has been reached. When 90 – 95% of the set temperature has been reached, the cook timer will begin counting down.

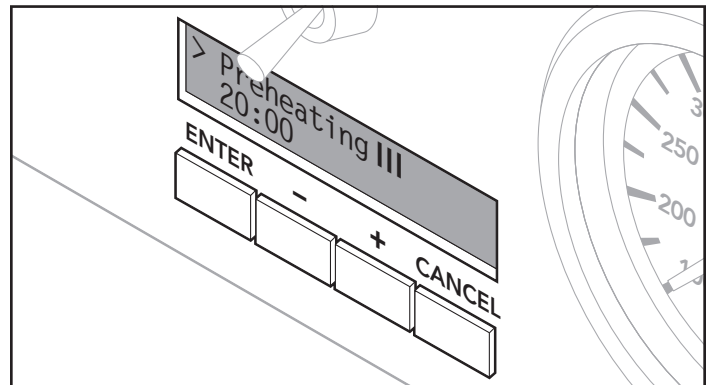

Note:

If you fail to press **ENTER** within 10 seconds, the screen will prompt you with “Hit Enter To Continue”, which will scroll across the screen until you press the **ENTER** button or turn the Mode Selector Ring to OFF.

Important

Wipe down the oven cavity and the evaporator dish with the sponge provided and dry well with a soft cloth after each use.

Remove food residue and spills from the oven immediately after the appliance has cooled down. Burned on residue is very difficult to remove at a later time.

Salts are very abrasive and can cause rust spots. The steam oven cavity can rust if not properly cared for.

Temperature Setting for Each Cooking Mode

Different modes have different possible minimum and maximum temperatures. The following table describes the limits on setting the temperature ranges for each mode (except for EasyCook, described in a later section):

Cooking Mode	Minimum Temp.	Maximum Temp.	Second Line of SELECT TEMP. Display Will Show:	Notes on Using the Temperature Control Knob
TRUE CONVEC	100°F (40°C)	450°F (230°C)	0°	TRUE CONVEC can use the full range of oven temperatures
REHEAT	210°F (100°C)	360°F (180°C)	0°	If you rotate the knob below 225°F (105°C), the display will show "210°F (100°C) Min". If you rotate it higher than 350°F (180°C), the display will show "360°F (182°C) Max".
DEFROST	110°F (45°C)	110°F (45°C)	110°F (45°C)	Cannot use the knob
SLOW COOK	140°F (60°C)	250°F (120°C)	0°	If you rotate the knob below 150°F (65°C), the display will show "140°F (60°C)". If you rotate it higher than 250°F (120°C), the display will show "250°F (120°C) Max".
PROOF	100°F (38°C)	100°F (38°C)	100°F (38°C)	Cannot use the knob
STEAM/ CONVEC	250°F (120°C)	450°F (230°C)	0°	If you rotate the knob below 250°F (120°C), the display will show "250°F (120°C) Max".
STEAM	212°F (100°C)	212°F (100°C)	212°F (100°C)	Cannot use the knob

Changing the Temperature during Operation

CHANGING DURING PREHEAT: If the new temperature you choose is higher than the current one, the oven will resume preheating, recalculating the number of preheat bars to show progress to the new temperature.

If the new temperature is lower than the current one (or within 95% of it), the oven will go directly to cooking. The "Cook Timer" and the remaining countdown time will be displayed. For foods that could be damaged by the higher original cooking temperature, wait a few minutes before placing the dish in the oven, and reset the Cook Timer if necessary.

CHANGING AFTER PREHEAT: If you change the temperature once the cooking temperature has been reached, the oven will ramp the interior temperature up or down to the new temperature. The cook timer will continue counting down without being affected.

If the food you are placing in the oven at the lower temperature could be damaged by a higher original temperature, wait a few minutes for the oven to cool down to the lower temperature before adding the dish. Reset the Cook Timer as necessary.

Automatic operation of the cooling blower

The cooling blower activates immediately for any of the steam oven modes. If steam oven modes that use steam are switched off (*Steam, Steam Convec, Reheat, Defrost, or Proof*), the cooling blower stays on for 10 minutes independent from the oven temperature before shutting off. If heating modes without steam are turned off, the cooling blower goes off when the oven temperature falls below 230°F (110°C).

If the door is opened during a mode that uses the steam function, the cooling fan will cycle on and off five-six times in succession to purge the excess steam.

Evaporator dish operation

Steam, Steam Convec, Defrost, and certain settings of *EasyCook* will have a rolling boil at the evaporator dish of the steam oven whereas the remaining modes will not. This is due to the need for a higher temperature setting needed for these processes. *True Convec, Reheat, Slow Cook*, and *Proof* are gentler steaming processes and require a drier heat and less moisture content.

Changing the Cooking Time during Operation

1. Press **CANCEL**. The display will show CANCEL COOK TIMER.
2. Press **ENTER** to cancel the mode.
3. Press **ENTER** again to return to the main menu.
4. Using the “+/-” buttons, scroll to COOK TIMER.
5. Press **ENTER** to get the blinking (0:00).
6. Using the “+/-” buttons, input the new cooking time.
7. Press **ENTER** to restart the cook timer.

Canceling the Mode

To cancel a cooking mode, press the **CANCEL** button. A prompt will appear asking if you want to cancel the mode (e.g., CANCEL STEAM/CONVEC) on the first line of the display screen.

If the oven is preheating, the preheat temperature will show on the second line. If the oven is past preheat, “Cook Timer” will display on the first line, and the countdown time on the second.

To stop the operation, press **ENTER**. The display screen will go blank. Turn the Mode Selector Ring to OFF.

To continue cooking, press **CANCEL** again. If the oven was in preheat, heating will resume and the preheating bars will show on the display. If the oven was past preheat, then “Cook Timer” and the countdown time will continue to display.

At the End of Cooking

When the cook timer reaches 0:00, the display will emit a repeated double beep to signal the end of the cooking time.

The display will show “Cook Time” on the first line and “Finished” on the second. The double beep will continue until you turn either the Mode Selector Ring or the Temperature Control Knob to OFF.

Pressing the **CANCEL** button will also disable the beep even if the oven has not been turned to OFF. Turn both the knob and the ring to OFF.

If 30 minutes passes with no further action to stop the timer or to turn the oven off, the beeping will stop, the display will go blank, and the steam oven heating element will turn off.

After cooking with a steam-producing mode, remember to remove and empty the water tank, dry the seal of the tank lid and the slot. Using the sponge provided with your range (or a comparable soft sponge or cloth), wipe out the oven and remove any remaining water so that the evaporator dish in the bottom of the oven is dry.

Features Available When the Steam Oven Is Set to OFF

When the oven is off, push any button to bring up the two choices displayed on the screen: “Kitchen Timer” and “Settings”. These two options are **ONLY** available when the Mode Selector Ring is set to OFF. Review the **SETTINGS** when you begin using the oven.

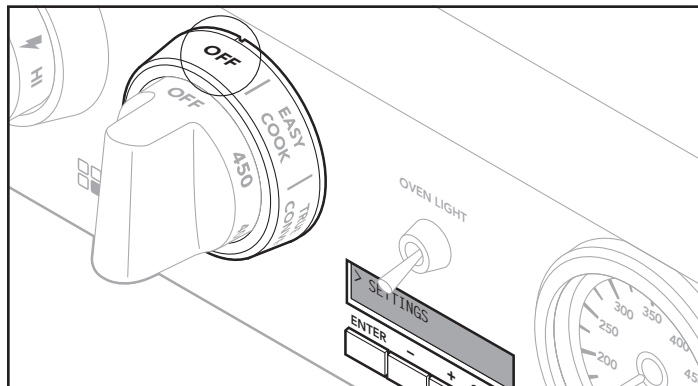

Steam Oven Settings

Several oven features can be adjusted by selecting the **SETTINGS** menu from the initial options on the display screen. Many of these features should be adjusted when the oven is first installed or after a move to a new location. Using the “+/-” buttons, choose **SETTINGS** and press **ENTER**. The following list of settings will display:

- Country Code
- Temperature Units
- Weight Units
- Calibration
- Water Hardness
- Descal
- Steam Clean
- Factory Reset

Use the “+/-” buttons to scroll through the settings list, pressing **ENTER** for the one you wish to adjust.

COUNTRY CODE: Instead of manually changing weight or temperature units, you can go to **COUNTRY CODE** and select either **USA** or **CANADA**. Choosing **USA** defaults the weight and temperature units to lbs./°F. Choosing **CANADA** defaults these settings to kg/°C. The Country Code display will change to **CUSTOM** if you change either of the units by going directly to them in the settings list.

TEMPERATURE UNITS: If you choose this setting, you can override the **COUNTRY CODE** default and manually select either degrees Fahrenheit (°F) or Celsius (°C) for the temperature display. The calculation for conversion between temperatures in Fahrenheit and Celsius is shown below (T = temperature):

$$T^{\circ}(\text{Fahrenheit}) = T^{\circ}(\text{Celsius}) \times 9/5 + 32$$

WEIGHT UNITS: If you choose this setting, you can override the COUNTRY CODE default and manually select either pounds (lbs.) or kilograms (kg) for food weight entry. The calculation for conversion between weights in pounds and kilograms is shown below ($W = \text{Weight}$):

$$W (\text{Pounds}) = W (\text{kilograms}) / 2.2$$

CALIBRATION: This setting resets the temperature calibration to 210°F (100°C) the next time the STEAM mode is used. (See also “Automatic Calibration” on page 48).

WATER HARDNESS: The hardness of the tap or bottled water (**NEVER** distilled water) you put in the water tank should be determined and entered with this setting when the range is installed. As explained on page 49, you may either use the water hardness strips that come with your range, or contact your local water utility to find out the hardness of your tap water. Enter WATER HARDNESS and set it to this value using the “+/-” buttons for the number scale. If you move or if your water source changes, you will need to reset the water hardness value.

DESCALE: Your steam oven will need to be descaled (or decalcified) at regular intervals to remove the calcium and magnesium deposits from the water heated to make steam. Once the water hardness is set, the steam oven display will automatically alert you when descaling is required.

Note:

If you use softened water, you will not need to descale the steam oven.

Detailed instructions for descaling the steam oven are provided in the “Care and Maintenance” section of this manual starting on page 77. The oven cannot be used for any other purpose while descaling is in progress.

STEAM CLEAN: You may use steam to dissolve food residues and spills so that they can be easily wiped up. Running the STEAM CLEAN cycle takes 30 – 35 minutes, and the oven cannot be used for any other purpose while steam cleaning is underway. Detailed instructions for steam cleaning the oven are provided in the “Care and Maintenance” section of this manual starting on page 77.

FACTORY RESET: This feature will restore all settings to these default values:

- Country Code: USA
- Temperature Units: Fahrenheit
- Weight Units: Pounds
- Calibration: On
- Water Hardness: 3 – Medium

Kitchen or Cook Timer

To set the kitchen or cook timer

1. With the “+/-” buttons, move the arrow (>) to “Kitchen Timer” or “Cook Timer” and press **ENTER**.
2. Using the “+/-” buttons, select the desired countdown time.
3. Press **ENTER** to begin the timer countdown.
4. When the timer reaches “0:00”, the display will emit a repeated single beep to signal the end of the countdown.
5. Press **CANCEL** to disable the beep.

The longest possible countdown time is 12 hours. If you keep pressing “+” when the timer has reached this maximum setting, the system will give a long beep each time the “+” button is pressed to remind you that this limit has been reached.

If you select the minimum cooking time of (0:00), and keep pressing the “-” button, the display will remain at 0:00 and give a long beep each time the “-” button is pressed.

For times longer than one hour (1:00), the remaining time will show as HR/MIN (e.g., 2:40 min). From less than one hour to 10 minutes, it shows as MIN/SEC (e.g., 5:40 sec). The colon (:) in the time display will blink every second when the countdown time is 10 minutes or more.

Below 10 minutes, the time will display in seconds (e.g., 9:53, 8:45, and so on) with no blinking.

While the timer is operating, pressing **CANCEL** will lead to a prompt: “Cancel Timer” on the first line, while the time still shows on the second line. Press **ENTER** to stop the countdown and the timer operation. Press **CANCEL** to resume the countdown.

Remember: The kitchen timer on the steam oven is only available when the steam oven is set to OFF.

EasyCook Automatic Programming

Introduction to EasyCook™

Automatic programming makes it easy to prepare food. Your steam oven's EasyCook mode automatically sets the oven to cook 27 different foods.

The following pointers will help you get excellent results with EasyCook:

- Use only **ONE** level of the oven with EasyCook programs.
- Use the recommended ovenware. All meals have been tested using this ovenware, and results may vary if different ovenware is used.
- When cooking food in a perforated cooking pan, insert the baking pan at rack level 1 to catch any drippings.
- Add liquid and food mixtures such as rice and water no more than 1.6 inches up the side of the cooking pan.
- Automatic programming requires that you know the weight of the food. For individual pieces, like pieces of chicken, always enter the weight of the largest piece. The total weight must be within the preset weight range.
- Cooking results may vary depending on the amount and quality of the food.
- You can change the cooking time during the first 10 minutes, since the preheat time depends on conditions such as the temperature of the water and of the food being cooked.

Setting EasyCook Programs

Choosing the Food

1. Turn the Mode Selector Ring to EASYCOOK. The display screen will show a list of food groupings with EasyCook programs. These groupings are "Vegetables", "Rice", "Poultry", "Meat", "Fish", "Breads".
2. Starting with the selection arrow (>) at "Vegetables", use the "+/—" buttons to scroll through the list of choices.
3. Select the desired food grouping and press **ENTER**. The screen will show the sub-groups of foods under the grouping you selected. For example, under "Meat" the choices are "Beef", "Pork" and "Lamb". Note that "Pork" has only one choice, Pork Roast. Hit **ENTER** again to go to Pork Roast.
4. Use the "+/—" buttons to scroll forward and back through the sub-group choices under that food grouping.

5. Select the sub-group you want and press **ENTER**. The meat grouping has a second level of choice: For example, at "Beef", you can choose a program for "Sirloin", "Medium", Or "Pot Roast".

Setting the Weight

The display will now show "Enter Weight" on the first line and a weight ("X.0" lbs. or kg) on the second line. X.0 lbs. is the default weight for the selected food. For instance, if you select "Meat", then "Pork", then "Pork Roast", the default weight is 2.0 lbs. so X = 2.

6. Use the "+/—" buttons to adjust the weight of the food you will be cooking. Pressing the "+/—" buttons will change the displayed weight by 0.1 pounds (or kilograms, according to the chosen settings). Each type of food has a maximum and minimum weight setting for EasyCook. Holding down the "+/—" button will allow you to scroll rapidly through the weight choices.

At the maximum weight setting (for example, 4.5 lbs. for a fresh whole chicken), if the "+" button is pressed again, the display will continue to show a weight of 4.5 lbs. and the oven will beep each time the "+" button is pressed. Likewise, at the minimum weight setting (for example, 1.6 lbs. for a fresh whole chicken), if the "-" button is pressed again, the display will continue to show a weight of 1.6 lbs. and the oven will beep each time the "-" button is pressed.

Changing the Food Type and Weight Already Selected

At each level, pressing **CANCEL** will take you back to the previous menu until you reach the main EasyCook menu (Vegetables, Rice, etc.).

At the food groupings level (Vegetables, Rice, etc.), pressing **CANCEL** will cause the oven to beep. The screen will show that same menu until another button is pressed, or the Mode Selector Ring is turned to OFF. At this point the display will go blank.

Starting Cooking

In EasyCook programs, the rack location, baking pan type, and cooking times have been pre-selected for the food type and weight you have chosen.

7. Press **ENTER** again. The display will show the rack level (levels 1 – 3) and specific ovenware/accessories that should be used.
8. Place food in steam oven.
9. Press **ENTER** again. The display will show “Cook Timer” on the first line and the automatic cooking time for the particular choice of food on the second line.
10. Press **ENTER** and the oven will begin preheating. The preheat bars, 1 bar up to 4, will display on the first line and the current oven temperature on the second. Once the oven reaches 90 – 95% of the pre-selected temperature, the cook time countdown will be activated.

During Cooking

After preheat, the display will indicate the specific cooking mode being used, the automatic temperature for that program (for example, “Steam - 212°”), and the automatic cooking time.

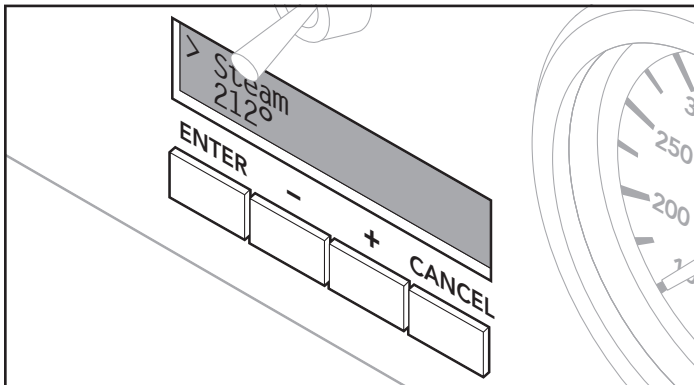

The cook timer will now begin counting down from that automatic time to 0:00 in the same manner as all the other cooking cycles.

At the End of an EasyCook™ Program

When the cook timer reaches 0:00, the EasyCook program will end. The display will beep to signal the end of the cooking time.

The display will show “Cook Time” on the first line and “Finished” on the second line and beep until you turn the Mode Selector Ring or the Temperature Control Knob to OFF.

Pressing the **CANCEL** button will also disable the buzzer even if the oven has not been turned to OFF.

If 30 minutes passes with no further action to stop the timer beep or turn the oven off, the beep will stop and the display will go blank.

Canceling the Program during Operation

While an EasyCook mode is running, if you press **CANCEL**, the display prompt will read “Cancel EasyCook?” If the oven is still preheating, the preheat temperature will display on the second line. If the oven has reached cooking temperature, the countdown time will display on the second line.

To stop the operation, press **ENTER**. The screen will go blank. Turn the Mode Selector Ring to OFF.

To continue cooking, press **CANCEL** again. If the oven was in preheat, heating will resume and the preheating bars will show on the display. If the oven was past preheat, then “Cook Timer” and the countdown time will continue to display.

EasyCook Program Charts

This section covers all of the programs available for automatic programming. Read the instructions before using a program to prepare the food.

Food	Default Weight	Duration Default Weight	Min. Weight	Max. Weight	Duration at Min. Weight	Duration at Max. Weight	Accessories and Rack Levels
------	----------------	-------------------------	-------------	-------------	-------------------------	-------------------------	-----------------------------

Vegetables

Wait until after cooking to season vegetables, including potatoes.

Cauliflower florets	1.1 lbs. (0.5 kg)	0:10:00	0.3 lbs. (0.2 kg)	4.1 lbs. (2 kg)	0:10:00	0:10:00	Perforated (level 3) + baking pan (level 1)
Green beans	1.1 lbs. (0.5 kg)	0:18:00	0.3 lbs. (0.2 kg)	4.1 lbs. (2 kg)	0:18:00	0:18:00	Perforated (level 3) + baking pan (level 1)
Broccoli florets	1.1 lbs. (0.5 kg)	0:07:00	0.3 lbs. (0.2 kg)	4.1 lbs. (2 kg)	0:07:00	0:07:00	Perforated (level 3) + baking pan (level 1)
Green asparagus (of equal size)	1.1 lbs. (0.5 kg)	0:15:00	0.3 lbs. (0.2 kg)	4.1 lbs. (2 kg)	0:15:00	0:15:00	Perforated (level 3) + baking pan (level 1)
Mixed veggies, frozen	1.1 lbs. (0.5 kg)	0:06:00	0.3 lbs. (0.2 kg)	4.1 lbs. (2 kg)	0:06:00	0:06:00	Perforated (level 3) + baking pan (level 1)
Potatoes, peeled	1.1 lbs. (0.5 kg)	0:25:00	0.3 lbs. (0.2 kg)	4.1 lbs. (2 kg)	0:25:00	0:25:00	Perforated (level 3) + baking pan (level 1)
Potatoes, unpeeled	1.1 lbs. (0.5 kg)	0:37:00	0.3 lbs. (0.2 kg)	4.1 lbs. (2 kg)	0:37:00	0:37:00	Perforated (level 3) + baking pan (level 1)

Cereals and Grains

Weigh out the food to be cooked and add the correct amount of water:

Rice 1:1.5, Couscous 1:1

Stir the cereal or grain after cooking to help it quickly absorb the remaining water.

To prepare risotto, add water to the risotto at a ratio of 1:2. Enter the entire weight, including the water. One cup of risotto and 2 cups of water equal approximately 1.5 lbs. (0.68 kg). The message "stir" will appear after approximately 15 minutes. Stir the risotto, and continue cooking.

Long grain		0:25:00					Cooking pan (level 2)
Basmati		0:20:00					Cooking pan (level 2)
Brown rice		0:30:00					Cooking pan (level 2)
Couscous		0:08:00					Cooking pan (level 2)
Risotto, arborio rice	2.2 lbs. (1 kg)	0:30:00	1.0 lbs. (0.5 kg)	4.2 lbs. (2 kg)	0:30:00	0:30:00	Cooking pan (level 2)

Food	Default Weight	Duration Default Weight	Min. Weight	Max. Weight	Duration at Min. Weight	Duration at Max. Weight	Accessories and Rack Levels
Poultry							
Weigh individual pieces of chicken. Enter the weight of the heaviest piece. DO NOT place pieces of chicken on top of one another in the ovenware. You can marinate the pieces of chicken before cooking.							
Fresh whole chicken	2.2 lbs. (1 kg)	0:56:00	1.6 lbs. (0.7 kg)	4.5 lbs. (1.5 kg)	0:51:00	1:04:00	Wire rack + baking pan (level 2)
Fresh chicken portions	0.2 lbs. (0.1 kg)	0:36:00	0.1 lbs. (0.04 kg)	0.8 lbs. (0.36 kg)	0:33:00	0:47:00	Wire rack + baking pan (level 2)
Beef							
A tall roast is recommended for roast beef.							
Pot roast	2.2 lbs. (1 kg)	1:40:00	2.2 lbs. (1 kg)	3.3 lbs. (1.5 kg)	1:40:00	1:52:00	Baking pan (level 2)
Sirloin, medium, slow cook (sear before cooking)	2.2 lbs. (1 kg)	2:02:00	2.2 lbs. (1 kg)	4.2 lbs. (2 kg)	2:02:00	2:08:00	Baking pan (level 2)
Pork							
Cut the rind from the center outward before cooking. The shoulder cut is the best cut for a pork roast with crust.							
Pork Roast	2.2 lbs. (1 kg)	1:22:00	1.8 lbs. (0.8 kg)	4.2 lbs. (2 kg)	1:17:00	1:44:00	Wire rack + baking pan (level 2)
Lamb (Bone-in leg of lamb)							
Leg, well done	2.2 lbs. (1 kg)	1:14:00	2.2 lbs. (1 kg)	4.2 lbs. (2 kg)	1:14:00	1:44:00	Wire rack + baking pan (level 2)
Leg, medium	2.2 lbs. (1 kg)	1:50:00	2.2 lbs. (1 kg)	4.2 lbs. (2 kg)	1:50:00	2:52:00	Baking pan (level 2)
Fish							
Grease the perforated cooking pan to prepare for the fish. DO NOT place whole fish, fish fillets, or fish sticks on top of each other. Enter the weight of the heaviest piece of fish and select pieces that are approximately the same size.							
Whole fresh fish	1.3 lbs. (0.6 kg)	0:25:00	0.7 lbs. (0.3 kg)	4.1 lbs. (2 kg)	0:18:00	0:58:00	Perforated (level 3) + baking pan (level 1)
Fresh fish fillet	0.4 lbs. (0.2 kg)	0:15:00	0.2 lbs. (0.1 kg)	4.0 lbs. (2 kg)	0:15:00	0:15:00	Perforated (level 3) + baking pan (level 1)
Oysters & clams	2.2 lbs. (1 kg)	0:10:00	1.2 lbs. (0.5 kg)	5.2 lbs. (2.5 kg)	0:10:00	0:10:00	Perforated (level 3) + baking pan (level 1)
Breads							
Use parchment paper on the baking pan when baking breads and rolls. EasyCook programs are for free-form loaves only. Baking bread in a loaf pan is not recommended. The dough should not be too soft. Before baking, use a sharp knife to make several slashes, about 0.4" (1 cm) deep into the bread dough. Let the dough rise before baking. The EasyCook program is for baking only. Fresh rolls should all weigh the same. Enter the weight of the individual bread rolls.							
Braided loaf	2.2 lbs. (1 kg)	0:47:00	1.0 lbs. (0.5 kg)	4.2 lbs. (2 kg)	0:38:00	1:02:00	Baking pan (level 2)
Multigrain	2.2 lbs. (1 kg)	0:44:00	1.4 lbs. (0.6 kg)	4.2 lbs. (2 kg)	0:39:00	0:57:00	Baking pan (level 2)
White bread	2.2 lbs. (1 kg)	0:47:00	1.0 lbs. (0.5 kg)	4.2 lbs. (2 kg)	0:38:00	1:02:00	Baking pan (level 2)
Rye bread	2.2 lbs. (1 kg)	0:53:00	1.4 lbs. (0.6 kg)	4.2 lbs. (2 kg)	0:46:00	1:09:00	Baking pan (level 2)
Fresh rolls	0.1 lbs. (0.05 kg)	0:27:00	0.1 lbs. (0.05 kg)	0.6 lbs. (0.3 kg)	0:27:00	0:52:00	Baking pan (level 2)

Getting the Most Out of Your Steam Oven

Cooking Tables and Tips

These tables contain a selection of dishes that can be easily prepared in the steam convection oven. You can find out which oven mode, accessories and cooking time are best suited for your dish. If not specified otherwise, this information applies to dishes placed in a cold appliance.



WARNING:

DO NOT use aluminum foil or protective liners to line any part of the appliance, especially the oven bottom. Installing these liners may result in risk of electric shock or fire.

Accessories

Use the accessories that come with the appliance.

Ovenware

If you use ovenware, always place it in the center of the rack.

The ovenware must be heat and steam resistant. Thick-walled ovenware extends the cooking time.

Use foil to cover food that would normally be prepared in a water bath (such as when melting chocolate).

Steaming

Steaming is a particularly gentle way to cook food. The steam envelopes the food, preventing the food from losing nutrients. No excess pressure is needed for cooking, allowing the food to maintain its shape, color and typical flavor.

Cooking Times and Quantities

When steaming, the cooking times are based on the size of the piece, not on the entire quantity of food. The appliance can steam up to 14 lbs. (6.4 kg) of food.

Note the sizes of pieces listed in the tables. The cooking time is shorter for smaller pieces and longer for larger pieces. The quality and age of the food also affect the cooking time. The values provided therefore serve only as a guideline.

Distribute Food Evenly

Always distribute the food evenly in the ovenware. If the food is placed unevenly in the ovenware, it will cook unevenly.

Delicate Food

Do not layer delicate foods too high in the cooking pan. It is better to use two pans in this case.

Cooking an Entire Meal

You can cook entire meals at the same time in Steam mode without mixing the flavors of the different food. Place the food with the longest cooking time in the appliance first and then add the remaining dishes at the appropriate time. This will ensure that all dishes are ready at the same time.

The total cooking time will be longer when cooking an entire meal, since every time the appliance door is opened, some steam escapes and the appliance has to reheat.

True Convection

True Convection is particularly suited for sweet and savory baked goods, braised meat and various cakes.

Vegetables

Place vegetables in the perforated cooking pan and place pan at rack level 3. Place the baking pan underneath it at rack level 1. The baking pan will catch any drippings.

Food	Size	Accessories	Oven Mode	Temperature	Cooking Time
Artichokes	Whole	Perforated + baking pan	Steam	210°F (100°C)	30 – 35 min.
Cauliflower	Whole	Perforated + baking pan	Steam	210°F (100°C)	30 – 40 min.
Cauliflower	Florets	Perforated + baking pan	Steam	210°F (100°C)	10 – 15 min.
Broccoli	Florets	Perforated + baking pan	Steam	210°F (100°C)	8 – 10 min.
Peas	–	Perforated + baking pan	Steam	210°F (100°C)	5 – 10 min.
Fennel	Slices	Perforated + baking pan	Steam	210°F (100°C)	10 – 14 min.
Stuffed vegetables (zucchini, eggplant, peppers)	DO NOT precook vegetables	Baking pan at level 2	Combination	320 – 360°F (160 – 180°C)	15 – 30 min.
Green beans	–	Perforated + baking pan	Steam	210°F (100°C)	15 – 20 min.
Carrots	Slices	Perforated + baking pan	Steam	210°F (100°C)	10 – 20 min.
Kohlrabi	Slices	Perforated + baking pan	Steam	210°F (100°C)	15 – 20 min.
Leeks	Slices	Perforated + baking pan	Steam	210°F (100°C)	4 – 6 min.
Swiss Chard*	Shredded	Perforated + baking pan	Steam	210°F (100°C)	8 – 10 min.
Green asparagus*	Whole	Perforated + baking pan	Steam	210°F (100°C)	7 – 12 min.
White asparagus*	Whole	Perforated + baking pan	Steam	210°F (100°C)	10 – 15 min.
Spinach*	–	Perforated + baking pan	Steam	210°F (100°C)	2 – 3 min.
Brussels sprouts	Florets	Perforated + baking pan	Steam	210°F (100°C)	20 – 30 min.
Red beets	Whole	Perforated + baking pan	Steam	210°F (100°C)	40 – 50 min.
Red cabbage	Shredded	Perforated + baking pan	Steam	210°F (100°C)	30 – 35 min.
Cabbage	Shredded	Perforated + baking pan	Steam	210°F (100°C)	25 – 35 min.
Zucchini	Slices	Perforated + baking pan	Steam	210°F (100°C)	2 – 3 min.
Pea pods	–	Perforated + baking pan	Steam	210°F (100°C)	8 – 12 min.

* Preheat the appliance. Place food in oven before preheat unless using the Slow Cook or True Convection modes.

Side Dishes and Legumes

Add the appropriate amount of water or liquid. Example: 1:1.5 = for every 1/2 cup.

Food	Ratio/ Information	Accessories	Oven Mode	Temperature	Cooking Time
Potatoes (unpeeled)	Medium size	Perforated (level 3) + baking pan (level 1)	Steam	210°F (100°C)	35 – 45 min.
Potatoes (peeled)	Quartered	Perforated (level 3) + baking pan (level 1)	Steam	210°F (100°C)	20 – 25 min.
Potato gratin	–	Baking pan (level 2)	Steam	210°F (100°C)	35 – 45 min.
Brown rice	1:2	Cooking pan	Steam	210°F (100°C)	30 – 40 min.
Long grain rice	1:2	Cooking pan	Steam	210°F (100°C)	20 – 30 min.
Basmati rice	1:1.5	Cooking pan	Steam	210°F (100°C)	20 – 30 min.
Parboiled rice	1:1.5	Cooking pan	Steam	210°F (100°C)	15 – 20 min.
Lentils	1:2	Cooking pan	Steam	210°F (100°C)	30 – 45 min.
Canellini beans, pre-softened	1:2	Cooking pan	Steam	210°F (100°C)	65 – 75 min.
Couscous	1:1	Cooking pan	Steam	210°F (100°C)	6 – 10 min.
Dumplings	–	Perforated (level 3) + baking pan (level 1)	Steam	205°F (95°C)	20 – 25 min.

Meat, Poultry, Fish

Insert rack and baking pan together at the same rack level. Once the roast is done, let it rest in the closed convection steam oven for an additional 10 minutes after turning it off. This will help the meat retain its juices.

Using the Combination oven mode makes the meat particularly tender and juicy on the inside while forming a crust on the outside.

Food	Amount/ Weight	Accessories	Oven Mode	Temperature	Cooking Time
Poultry					
Chicken, whole	2.65 lbs. (1.2 kg)	Wire rack + baking pan (level 2)	Combination	360 – 375°F (180 – 190°C)	50 – 60 min.
Chicken, halved	per 1 lbs. (0.4 kg)	Wire rack + baking pan (level 2)	Combination	360 – 375°F (180 – 190°C)	35 – 45 min.
Chicken breast	per 0.33 lbs. (0.15 kg)	Perforated (level 3) + baking pan (level 1)	Steam	210°F (100°C)	15 – 25 min.
Chicken pieces	per 2.65 lbs. (1.2 kg)	Wire rack + baking pan (level 2)	Combination	360 – 375°F (180 – 190°C)	20 – 35 min.
Duck, whole	4.5 lbs. (2 kg)	Wire rack + baking pan (level 2)	Combination/ True convection	340°F (170°C)/ 410°F(210°C)	60 – 80 min./ 15 – 20 min.
Duck breast*	per 0.77 lbs. (0.35 kg)	Wire rack + baking pan (level 2)	Combination	360 – 375°F (180 – 190°C)	10 – 15 min.
Turkey, whole, unstuffed	8 – 11 lbs.	Wire rack + baking pan (level 2)	Combination	325°F (165°C)	50 – 75 min.
Turkey, whole, unstuffed**	12 – 14 lbs.	Wire rack + baking pan (level 2)	Combination	325°F (165°C)	80 – 95 min.

* Sear first

** Use baking pan 1 5/8" deep (see Additional Accessories)

Food	Amount/ Weight	Accessories	Oven Mode	Temperature	Cooking Time
Rolled turkey roast	3.5 lbs. (1.5 kg)	Wire rack + baking pan (level 2)	Combination	300 – 320°F (150 – 160°C)	70 – 90 min.
Turkey breast	2 lbs. (1 kg)	Wire rack + baking pan (level 2)	Combination	300 – 320°F (150 – 160°C)	60 – 80 min.
Beef					
Pot-roasted beef*	3.5 lbs. (1.5 kg)	Wire rack + baking pan (level 2)	Reheat	285 – 300°F (140 – 150°C)	100 – 140 min.
Filet of beef, medium*	2 lbs. (1 kg)	Wire rack + baking pan (level 2)	Reheat	340 – 360°F (170 – 180°C)	20 – 28 min.
Thin slice of roast beef, medium*	2 lbs. (1 kg)	Wire rack + baking pan (level 2)	True Convection	340 – 360°F (170 – 180°C)	40 – 55 min.
Thick slice of sirloin, medium*	2 lbs. (1 kg)	Wire rack + baking pan (level 2)	True Convection	340 – 360°F (170 – 180°C)	45 – 60 min.
Veal					
Veal, bone-in	3.5 lbs. (1.5 kg)	Wire rack + baking pan (level 2)	Combination	320 – 360°F (160 – 180°C)	50 – 70 min.
Veal loin	2 lbs. (1 kg)	Wire rack + baking pan (level 2)	Combination	320 – 360°F (160 – 180°C)	15 – 25 min.
Breast of veal, stuffed	3.5 lbs. (1.5 kg)	Wire rack + baking pan (level 2)	Combination	285 – 320°F (140 – 160°C)	75 – 120 min.
Pork					
Bone-in without rind	3.5 lbs. (1.5 kg)	Wire rack + baking pan (level 2)	Combination	320 – 360°F (160 – 180°C)	50 – 70 min.
Bone-in with rind	3.5 lbs. (1.5 kg)	Wire rack + baking pan (level 2)	Steam/ Combination	210°F (100°C)/ 285 – 320°F (140 – 160°C)	20 – 25 min. 40 – 50 min.
			True Convection	410 – 430°F (140 – 160°C)	20 min.
Pork chop, boneless*	1.2 lbs. (0.5 kg)	Wire rack + baking pan (level 2)	Combination	285 – 320°F (140 – 160°C)	75 – 120 min.
Fillet in puff pastry	2 lbs. (1 kg)	Baking pan (level 2)	Combination	360 – 390°F (180 – 200°C)	40 – 60 min.
Smoked pork on the bone	2 lbs. (1 kg)	Wire rack + baking pan (level 2)	Combination	250 – 285°F (120 – 140°C)	60 – 70 min.
Smoked pork ribs	Sliced	Baking pan (level 2)	Steam	210°F (100°C)	15 – 20 min.
Rolled roast	3.5 lbs. (1.5 kg)	Wire rack + baking pan (level 2)	Combination	340 – 360°F (170 – 180°C)	70 – 80 min.
Other					
Meat loaf	made from 1.2 lbs. (0.5 kg) ground meat	Baking pan (level 2)	Combination	340 – 360°F (170 – 180°C)	45 – 60 min.
Boned leg of lamb	3.5 lbs. (1.5 kg)	Wire rack + baking pan (level 2)	Combination	340 – 360°F (170 – 180°C)	60 – 80 min.
Loin of lamb on the bone*	3.5 lbs. (1.5 kg)	Wire rack + baking pan (level 2)	Combination	320 – 360°F (160 – 180°C)	15 – 25 min.
Wiener sausages	–	Perforated (level 3) + baking pan (level 1)	Steam	175 – 185°F (80 – 85°C)	12 – 18 min.

* Sear first

** Use baking pan 1 5/8" deep (see Additional Accessories)

Food	Amount/ Weight	Accessories	Oven Mode	Temperature	Cooking Time
Fish					
Whole	per 0.66 lbs. (0.3 kg)	Perforated (level 3) + baking pan (level 1)	Steam	175 – 195°F (80 – 90°C)	15 – 25 min.
Fillet	per 3.5 lbs. (1.5 kg)	Perforated (level 3) + baking pan (level 1)	Steam	175 – 195°F (80 – 90°C)	10 – 20 min.
Trout, whole	per 0.5 lbs. (0.2 kg)	Perforated (level 3) + baking pan (level 1)	Steam	175 – 195°F (80 – 90°C)	12 – 15 min.
Cod, fillet	per 0.33 lbs. (0.15 kg)	Perforated (level 3) + baking pan (level 1)	Steam	175 – 195°F (80 – 90°C)	10 – 14 min.
Salmon, fillet	per 0.33 lbs. (0.15 kg)	Perforated (level 3) + baking pan (level 1)	Steam	210°F (100°C)	8 – 10 min.
Clams, oysters	0.33 lbs. (0.15 kg)	Baking pan (level 2)	Steam	210°F (100°C)	10 – 15 min.
Haddock, perch fillet	per 0.5 lbs. (0.2 kg)	Perforated (level 3) + baking pan (level 1)	Steam	175 – 195°F (80 – 90°C)	10 – 20 min.
Stuffed sole rolls	–	Perforated (level 3) + baking pan (level 1)	Steam	175 – 195°F (80 – 90°C)	10 – 20 min.
Shrimp, large	per 1 lb (0.4 kg)	Perforated (level 3) + baking pan (level 1)	Steam	210°F (100°C)	8 – 13 min.
Shrimp, medium	per 1 lb (0.4 kg)	Perforated (level 3) + baking pan (level 1)	Steam	210°F (100°C)	5 – 8 min.

* Sear first

** Use baking pan 1 5/8" deep (see Additional Accessories)

Roasting Tips

When is the roast done?	Use a food thermometer (available in stores) to measure the meat temperature
The roast is too dark and crust is burned in some areas.	Check the rack level and temperature.
The roast turned out well, but the sauce is burned.	Next time, use a smaller roasting pan or add more liquid.
The roast looks good, but the sauce is too light and runny.	Next time, use a larger roasting pan or add less liquid.

Slow Cooking Meat

Slow cooking is ideal for cooking all tender cuts of meat that will be cooked medium rare. The meat stays very moist and is tender.

Place the baking pan in the combination oven and preheat the oven using Slow Cook mode. **Sear the meat well on all sides on the cooktop.** Place the meat in the preheated combination oven and continue to slow cook. After it is done, arrange it on preheated plates and add a warm sauce on top.

Food	Amount/Weight	Accessories	Temperature	Cooking Time
Boned leg of lamb	2 – 3.5 lbs. (1 – 1.5 kg)	Baking pan (level 2)	175°F (80°C)	140 – 160 min.
Roast beef	3.5 – 5.5 lbs. (1.5 – 2.5 kg)	Baking pan (level 2)	175°F (80°C)	150 – 180 min.
Pork fillets	–	Baking pan (level 2)	175 – 195°F (80 – 90°C)	50 – 70 min.
Pork medallions	–	Baking pan (level 2)	175°F (80°C)	50 – 60 min.
Beef steaks	approx. 1.2 in. thick	Baking pan (level 2)	175°F (80°C)	40 – 80 min.
Duck breast	–	Baking pan (level 2)	175°F (80°C)	35 – 55 min.

Souffles, Casseroles, Additions to Soups, etc.

Food	Accessories	Oven Mode	Temperature	Cooking Time
Lasagna	Baking pan (level 2)	Combination	320 – 340°F (160 – 170°C)	35 – 45 min.
Souffles	Souffle dish + wire rack (level 2)	Combination	360 – 390°F (180 – 200°C)	15 – 25 min.
Semolina dumplings	Perforated (level 3) + baking pan (level 1)	Steam	195°F (205°C)	7 – 10 min.

Desserts, Compotes

Compote: Weigh out the fruit, add approximately 1/3 of water and add sugar and spices to taste.

Rice pudding: Weigh out the rice and add 2.5 times as much milk. Add the rice and milk no higher than 1 inch up the side of the accessory. Stir after cooking. The remaining milk will be absorbed quickly.

Yogurt: Heat the milk on the cooktop to 195°F (90°C). Remove from heat and let cool to 105°F (40°C). Heating the milk is not required if using ultra high temperature (UHT) milk. Stir in one to two teaspoons of plain yogurt, or the appropriate amount of yogurt starter per 100 ml of milk. Pour the mixture into clean glass jars and cover with lids. After it is done, arrange it on preheated plates and add a warm sauce on top. After preparation, place the jars in the refrigerator to cool.

Food	Accessories	Oven Mode	Temperature	Cooking Time
Yeast dumplings	Baking pan	Steam	210°F (100°C)	20 – 25 min.
Egg custard	Mold + wire rack	Steam	195 – 205°F (90 – 95°C)	15 – 20 min.
Sweet baked items (such as rice pudding)	Ovenproof dish + wire rack	Combination	320 – 340°F (160 – 170°C)	50 – 60 min.
Rice pudding*	Baking pan	Steam	210°F (100°C)	25 – 35 min.
Yogurt	Portion-sized jars + wire rack	Steam	105°F (40°C)	300 – 360 min.
Apple compote	Baking pan	Steam	210°F (100°C)	10 – 15 min.
Pear compote	Baking pan	Steam	210°F (100°C)	10 – 15 min.
Cherry compote	Baking pan	Steam	210°F (100°C)	10 – 15 min.
Rhubarb compote	Baking pan	Steam	210°F (100°C)	10 – 15 min.
Plum compote	Baking pan	Steam	210°F (100°C)	10 – 15 min.

*You can also use the relevant program (see Automatic Programming).

Cakes and Baked Goods

Dark metal baking pans are recommended. The temperature and cooking time depend on the quantity and consistency of the dough. Temperature ranges are therefore provided in the charts. Start with a lower temperature setting. This will provide for more even browning. Use a higher temperature setting the next time, if necessary. **DO NOT** overfill the rack or baking pan.

Food	Accessories	Oven Mode	Temperature	Cooking Time
Cake in Molds or Springform Pans				
Sponge cake	10-inch tube pan (level 2)	True Convection	300 – 320°F (150 – 160°C)	60 – 70 min.
Sponge flan base	Ring (level 2)	True Convection	300 – 320°F (150 – 160°C)	30 – 45 min.
Delicate fruit flan, sponge	Springform cake pan (level 2)	True Convection	300 – 320°F (150 – 160°C)	45 – 55 min.
Sponge base (2 eggs)	Ring (level 2)	True Convection	360 – 375°F (180 – 175°C)	12 – 16 min.
Sponge flan (6 eggs)	Springform cake pan (level 2)	True Convection	300 – 320°F (150 – 160°C)	25 – 35 min.
Shortcrust pastry base with crust	Springform cake pan (level 2)	True Convection	300 – 320°F (150 – 160°C)	40 – 50 min.
Swiss flan	Springform cake pan (level 2)	True Convection	360 – 375°F (180 – 175°C)	35 – 60 min.
Bundt®	Bundt® cake pan (level 2)	Combination	300 – 320°F (150 – 160°C)	35 – 45 min.

Food	Accessories	Oven Mode	Temperature	Cooking Time
Savory cakes	Quiche dish (level 2)	True Convection	360 – 375°F (180 – 175°C)	35 – 60 min.
Apple tart	Flan base cake pan (level 2)	True Convection	340 – 375°F (170 – 190°C)	35 – 50 min.
Sheet cakes				
Yeast cake	Baking pan (level 2)	Combination/ True Convection	300 – 320°F (150 – 160°C)/ 300 – 320°F (150 – 160°C)	35 – 45 min. 35 – 45 min.
Swiss roll	Baking pan (level 2)	True Convection	360 – 375°F (180 – 175°C)	10 – 15 min.
Braided loaf	Baking pan (level 2)	Combination	300 – 320°F (150 – 160°C)	25 – 35 min.
Strudel, sweet	Baking pan (level 2)	Combination	320 – 360°F (160 – 180°C)	40 – 60 min.
Onion tart	Baking pan (level 2)	Combination	340 – 360°F (170 – 180°C)	30 – 40 min.
Bread, Bread Rolls				
White bread, 1.7 lbs. (0.75 kg) flour	Baking pan + parchment paper (level 2)	Combination/ True Convection	390 – 410°F (200 – 210°C)/ 320 – 340°F (160 – 170°C)	15 – 20 min./ 20 – 25 min.
Sourdough bread, 1.7 lbs. (0.75 kg) flour	Baking pan + parchment paper (level 2)	Combination/ True Convection	390 – 410°F (200 – 210°C)/ 300 – 320°F (150 – 160°C)	15 – 20 min./ 40 – 60 min.
Multigrain bread, 1.7 lbs. (0.75 kg) flour	Baking pan + parchment paper (level 2)	Combination/ True Convection	390 – 430°F (200 – 220°C)/ 320 – 340°F (160 – 170°C)	15 – 20 min./ 25 – 40 min.
Whole grain bread, 1.7 lbs. (0.75 kg) flour	Baking pan + parchment paper (level 2)	Combination/ True Convection	390 – 430°F (200 – 220°C)/ 285 – 300°F (140 – 150°C)	20 – 30 min./ 40 – 60 min.
Rye bread, 1.7 lbs. (0.75 kg) flour	Baking pan + parchment paper (level 2)	Combination/ True Convection	390 – 430°F (200 – 220°C)/ 300 – 320°F (150 – 160°C)	20 – 30 min./ 50 – 60 min.
Bread rolls, 0.15 lbs. (70 g) each, unbaked	Baking pan + parchment paper (level 2)	Combination	375 – 390°F (190 – 200°C)	25 – 30 min.
Bread rolls made with sweet yeast dough, 0.15 lbs. (70 g) each, unbaked	Baking pan + parchment paper (level 2)	Combination	340 – 360°F (170 – 180°C)	20 – 30 min.
Small Baked Products				
Meringue	Baking pan (level 2)	True Convection	175 – 195°F (80 – 90°C)	120 – 180 min.
Macaroons	Baking pan (level 2)	True Convection	285 – 320°F (140 – 160°C)	15 – 25 min.
Puff pastry	Baking pan (level 2)	Combination	340 – 375°F (170 – 190°C)	10 – 20 min.

Food	Accessories	Oven Mode	Temperature	Cooking Time
Muffins	Muffin pan (level 2)	True Convection	340 – 375°F (170 – 190°C)	20 – 30 min.
Choux pastry, such as cream puffs	Baking pan (level 2)	True Convection	340 – 375°F (170 – 190°C)	27 – 35 min.
Biscuits	Baking pan (level 2)	True Convection	300 – 320°F (150 – 160°C)	12 – 17 min.
Leavened cake, such as apple cake	Baking pan (level 2)	True Convection	300 – 320°F (150 – 160°C)	15 – 20 min.

Baking Tips

If using your own recipe.	Look at cakes or baked goods in the table that are similar to your recipe.
This will help to determine if the cake is cooked through.	About 10 minutes before the end of baking time according to your recipe, stick a toothpick into the highest part of the cake. The cake is done when the batter no longer sticks to the toothpick.
Cake collapses.	Next time, use less liquid or set oven temperature 20°F (10°C) lower. Use the mixing times specified in the recipe.
The center of the cake is higher than on the sides.	Do not grease the sides of the springform or cake pan. After baking, carefully remove the cake from the pan using a knife.
Springform or loaf cake is too dark in the back.	Do not place the baking pan up against the back wall of the oven. Place it on the center of the rack
Cake is too dry.	Use a toothpick to make small holes in the finished cake and pour drops of fruit juice or alcoholic beverage over the cake. Next time, set the temperature 20°F (10°C) higher and shorten the baking time or use the Combination oven mode.
The bread or cake looks good, but is runny inside (overly moist, has streaks of liquid running through it.)	Next time, use less liquid. Bake a little longer and at a lower temperature. Prebake crusts for pies and cakes with juicy/runny fillings. Sprinkle crust with almonds or bread crumbs and then add the filling. Use the baking time specified in the recipe.
Cakes or baked goods brown unevenly.	Set the temperature a little lower next time.

Reheating Foods

Food	Accessories	Oven Mode	Temperature	Cooking Time
Dinner plate	Wire rack (level 2)	Reheat	250°F (120°C)	12 – 18 min.
Vegetables	Baking pan (level 3)	Reheat	210°F (100°C)	12 – 15 min.
Noodles, potatoes, rice	Baking pan (level 3)	Reheat	210°F (100°C)	5 – 10 min.
Bread rolls*	Wire rack (level 2)	Combination	340 – 360°F (170 – 180°C)	6 – 8 min.
Baguettes*	Wire rack (level 2)	Combination	340 – 360°F (170 – 180°C)	5 – 10 min.
Bread*	Wire rack (level 2)	Combination	340 – 360°F (170 – 180°C)	8 – 12 min.
Pizza	Wire rack + baking pan (level 3)	Reheat	340 – 360°F (170 – 180°C)	12 – 15 min.

*Preheat for 5 minutes

Defrosting

Freeze the food as flat as possible and in appropriate portions at -0°F (-18°C). Do not freeze oversized portions. Defrosted food does not keep as long and spoils more quickly than fresh food. Defrost the food in the freezer bag on a plate or in the perforated cooking pan. Always slide the baking pan under the perforated cooking pan. This keeps the food from lying in the defrosted water and keeps the oven clean. Use the Defrost mode. If necessary, while the food is thawing, split it up or take pieces that have already thawed out of the appliance. Let the food sit for another 5 – 15 minutes after it has thawed to reach room temperature.



WARNING:

When defrosting animal food products, make sure to remove the thawed liquid. The liquid must not come into contact with other food products. Germs could be transferred to the other food. After the food has thawed, heat up the steamer oven using True Convection for 15 minutes at 360°F (180°C).

Defrosting meats: Thaw cuts of meat that will be breaded just until seasonings and bread crumbs can stick to the meat.

Defrosting poultry: Remove from packaging before defrosting. Make sure to pour out any defrosted liquid.

Food	Amount/Weight	Accessories	Temperature	Cooking Time
Chicken parts, bone-in	2 lbs. (1 kg)	Perforated (level 3) + baking pan (level 1)	115 – 120°F (45 – 50°C)	60 – 70 min.
Chicken parts, boneless	1 lb. (0.4 kg)	Perforated (level 3) + baking pan (level 1)	115 – 120°F (45 – 50°C)	30 – 35 min.
Block-frozen vegetables (such as spinach)	1 lb. (0.4 kg)	Perforated (level 3) + baking pan (level 1)	115 – 120°F (45 – 50°C)	20 – 30 min.
Berries	0.66 lbs. (0.3 kg)	Perforated (level 3) + baking pan (level 1)	115 – 120°F (45 – 50°C)	5 – 8 min.
Fish fillets	1 lb. (0.4 kg)	Perforated (level 3) + baking pan (level 1)	115 – 120°F (45 – 50°C)	15 – 20 min.
Beef	–	Perforated (level 3) + baking pan (level 1)	115 – 120°F (45 – 50°C)	70 – 80 min.

Proofing Dough

The dough rises much faster using this mode than at room temperature. You can choose any rack level for the rack or carefully place the rack on the oven bottom.

Place the dough-rising bowl on the rack. **DO NOT** cover the dough.

Food	Amount/Weight	Accessories	Temperature	Cooking Time
Yeast dough	2 lbs. (1 kg)	Bowl + wire rack	100°F (38°C)	20 – 30 min.
Sourdough	2 lbs. (1 kg)	Bowl + wire rack	100°F (38°C)	20 – 30 min.

Food	Accessories	Oven Mode	Temperature	Cooking Time
Yeast dough	Perforated (level 3) + cooking pan (level 1)	Steam	210°F (100°C)	30 – 45 min.
Sourdough	Perforated (level 3) + cooking pan (level 1)	Steam	210°F (100°C)	40 – 50 min.

Juice Extraction

Before extracting juice from berries, place the berries in a bowl and add sugar. Let the berries sit for one hour so that the juice is drawn out. Place berries in the perforated cooking pan and place pan at rack level 3. To catch the juice, place the non-perforated cooking pan at rack level 1. When ready, pour the berries into a cheese cloth and squeeze out the remaining juice.

Frozen Products

Follow the manufacturer's instructions on packaging. The specified cooking times apply to dishes placed in a cold oven.

Food	Accessories	Oven Mode	Temperature	Cooking Time
French fries	Baking pan + parchment paper (level 2)	True Convection	340 – 375°F (170 – 190°C)	25 – 35 min.
Croquettes	Baking pan + parchment paper (level 2)	True Convection	360 – 390°F (180 – 200°C)	18 – 22 min.
Thinly sliced fried potatoes	Baking pan + parchment paper (level 2)	True Convection	360 – 390°F (180 – 200°C)	25 – 30 min.
Pasta, fresh, refrigerated*	Baking pan + parchment paper (level 2)	Steam	210°F (100°C)	5 – 10 min.
Lasagna, frozen	Baking pan + wire rack (level 2)	Combination	375 – 410°F (190 – 210°C)	35 – 55 min.
Pizza, thin crust	Baking pan + wire rack (level 2)	True Convection	360 – 390°F (180 – 200°C)	15 – 23 min.
Pizza, deep dish	Baking pan + wire rack (level 2)	True Convection	360 – 390°F (180 – 200°C)	18 – 25 min.
Pizza, french bread	Baking pan + wire rack (level 2)	True Convection	360 – 390°F (180 – 200°C)	18 – 22 min.
Chilled pizza	Baking pan + parchment paper (level 2)	True Convection	340 – 360°F (170 – 180°C)	12 – 17 min.
Herb butter baguettes, refrigerated	Baking pan (level 2)	True Convection	360 – 390°F (180 – 200°C)	15 – 20 min.
Pretzels, frozen	Baking pan + parchment paper (level 2)	True Convection	360 – 390°F (180 – 200°C)	18 – 22 min.
Partially cooked bread rolls or baguettes, pre-baked	Baking pan + parchment paper (level 2)	True Convection	300 – 340°F (150 – 170°C)	18 – 22 min.
Strudel, frozen	Baking pan + parchment paper (level 2)	Combination	320 – 360°F (160 – 180°C)	45 – 60 min.
Fish sticks	Baking pan + parchment paper (level 2)	True Convection	380 – 400°F (195 – 205°C)	20 – 24 min.
Whole fish	Perforated (level 3) + cooking pan (level 1)	Steam	175 – 210°F (80 – 100°C)	20 – 25 min.
Frozen fish fillets	Baking pan + wire rack (level 2)	Combination	360 – 390°F (180 – 200°C)	35 – 50 min.
Salmon fillets	Perforated (level 3) + cooking pan (level 1)	Steam	175 – 210°F (80 – 100°C)	20 – 25 min.
Broccoli	Perforated (level 3) + cooking pan (level 1)	Steam	210°F (100°C)	4 – 6 min
Cauliflower	Perforated (level 3) + cooking pan (level 1)	Steam	210°F (100°C)	5 – 8 min.

*Add a little liquid

Food	Accessories	Oven Mode	Temperature	Cooking Time
Green beans	Perforated (level 3) + cooking pan (level 1)	Steam	210°F (100°C)	4 – 6 min
Peas	Perforated (level 3) + cooking pan (level 1)	Steam	210°F (100°C)	4 – 6 min
Carrots	Perforated (level 3) + cooking pan (level 1)	Steam	210°F (100°C)	3 – 5 min.
Mixed vegetables	Perforated (level 3) + cooking pan (level 1)	Steam	210°F (100°C)	4 – 8 min.
Brussels sprouts	Perforated (level 3) + cooking pan (level 1)	Steam	210°F (100°C)	5 – 10 min.

*Add a little liquid

Special Foods

Food	Size	Accessories	Oven Mode	Temperature	Cooking Time
Soft cooked eggs	Large	Perforated + (level 3) Baking Pan (level 1)	Steam	210°F (100°C)	9 – 11 min.
Hard cooked eggs	Large	Perforated + Baking Pan	Steam	210°F (100°C)	14 – 17 min.

Using the Warming Drawer



Warming Drawer

IMPORTANT:

Use **ONLY** heat-safe dishes in the warming oven.

The warming drawer will keep hot, cooked foods at serving temperature. Always start with hot food. **DO NOT** use the warming drawer to heat cold food other than crisping crackers, chips, and dry cereal or warming dishes or plates.



CAUTION:

Plastic containers or plastic wrap can melt if in direct contact with the drawer or a hot utensil. If it melts onto the drawer, it may not be removable.



WARNING:

DO NOT store flammable materials in the warming drawer. This includes paper, plastic or cloth items, such as cookbooks and towels, as well as flammable liquids.

DO NOT use the warming drawer to heat towels.

DO NOT store explosives, such as aerosol cans, in or near the drawer. Flammable materials may explode and result in fire or property damage.

Turning the Warming Drawer ON/OFF

The warming drawer will automatically shut off after 12 hours. The warming drawer will operate at three different temperatures: LOW, MED, and HIGH.

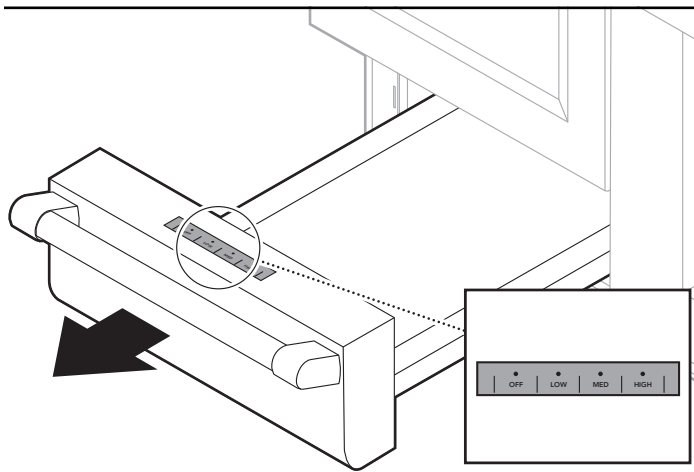

When a warming mode is selected, the blue indicator light for that mode illuminates.

Preheating the Warming Drawer

Preheat the warming drawer when keeping food warm. For best results, preheat for the following times:

- LOW: 5 minutes
- MED: 10 minutes
- HIGH: 15 minutes

Keeping Food Warm

1. Press the pad for the desired temperature setting.
2. Allow the drawer to preheat.
3. Place cooked, hot food in the drawer.

It is okay to leave food in the cookware it was prepared in. You can also transfer food to a heat-safe serving dish before placing it in the warming drawer. Aluminum foil may be used to cover food.

Warming Plates and Bowls

1. Place plates and bowls in warming drawer.
2. Press "HIGH".
 - Allow the cookware to heat up slowly as the warming drawer preheats.
 - **DO NOT** place cold plates in an already heated warming drawer. Placing a cold dish into a hot environment can cause the glass to expand rapidly, which may result in the cookware breaking.
3. Use pot holders to remove hot plates after heating.

Crisping Stale Items

Place food in low-sided dishes or pans.

1. Press "LOW".
2. Preheat for 5 minutes, then place dish in drawer.
3. Check crispness after 45 minutes. Continue crisping if needed.

Warming Drawer Recommendations

Food/Cookware	Level
Bacon ⁺	HIGH
Beef: rare, medium and well done ⁺	MED
Bread: hard rolls, soft rolls, coffee cakes, biscuits, toast ⁺	MED
Bread, quick: wraps, waffles, pancakes, pizza [*]	HIGH
Cakes: crumb cakes, muffins ⁺	HIGH
Casseroles ⁺	MED
Chocolate, broken (to melt) [*]	HIGH
Cereal, cooked ⁺	MED
Dough (to proof), cover ^{**}	LOW
Eggs: hard boiled, scrambled ⁺	MED
Fish, seafood ⁺	MED
Fried foods [*]	HIGH
Frozen foods: cream cakes, butter, cheese (to defrost)	LOW
Fruits ⁺	MED
Gelatin (to dissolve)	HIGH
Gravy, cream sauces ⁺	MED
Ham, Lamb and Pork ⁺	MED
Pie crusts ⁺	MED
Potatoes, baked ⁺	HIGH
Potatoes, mashed ⁺	MED
Poultry, roasted ⁺	MED
Sausage ⁺	HIGH
Vegetables ⁺	MED
Plates	HIGH
Cups, heat-safe	LOW
Plate of food ⁺	MED

* Preheat cookware

** Cover food

+ Preheat cookware & cover food



CAUTION:

To maintain food safety, **DO NOT** leave food in the oven for more than one hour before or after cooking.



WARNING:

DO NOT use aluminum foil or protective liners to line any part of the warming drawer, especially the oven bottom. Installation of these liners may result in a risk of electric shock or fire.

Care and Maintenance



Care and Maintenance

Self-Cleaning the Main Oven



WARNING:

- Children should not be left alone or unattended in an area where appliances are in use.
- During the Self-Clean cycle, exterior surfaces may become hotter than usual. Parts of the appliance may become potentially harmful to children, and to persons who lack adult knowledge of appliances and lack adult reactions to potentially harmful conditions. Keep these individuals away during self-clean and while the appliance is in use.
- The elimination of soil during self-cleaning may facilitate the emission of small amounts of chemicals or other substances that may be harmful upon sufficient exposure. To minimize exposure to these substances, provide good ventilation with an open window, or use a ventilation fan or hood.
- Keep pet birds out of the kitchen or other rooms where kitchen fumes could reach them. During self-clean, fumes are released that may be harmful to birds.

Main Oven

The self-cleaning mode of the large convection oven in your new range features pyrolytic self-cleaning. When set to the CLEAN mode, the oven reaches a high temperature, approximately 850°F (455°C), that burns off the food soil.

When the oven is set for CLEAN, the Standard cooktop STAR® burners, the electric griddle, and the warming drawer may be used. The steam oven and the outer STAR burners, having the ExtraLow® feature, cannot be used.

It is common to see smoke and/or flames during the clean cycle, depending on the content and amount of soil remaining in the oven. If a flame persists, turn off the oven and allow it to cool before opening the door to wipe up the excessive food soil.

At the end of the CLEAN cycle, some gray ash or burned residue may remain inside the oven. This is a mineral deposit that does not burn or melt. The amount of ash depends on how heavily soiled the oven was before it was cleaned. When the oven is cold, it is easily removed using a damp paper towel, sponge, or cloth.

Wipe off any smoke residue that remains on the front frame with Formula 409® or Fantastik® cleaners. If stain remains, use a mild liquid cleanser. The amount of smoke stain is directly related to the amount of food soil left in the oven at the time of self-cleaning. Clean the oven often.

Before Self-Cleaning the Oven

Wipe out puddles of grease and any loose soil that can be easily removed. Remove any soil that is outside the door seal area. This appliance is designed to clean the oven interior and the portion of the door that is inside the oven. The outer edges of the door and the frame surrounding the front of the oven are not in the cleaning zone. Wipe this area clean.

BEFORE SETTING THE OVEN TO SELF-CLEAN.

- Remove all utensils.
- Remove racks.
- Clean the oven front frame and outer door edges. Wipe up large spillovers and grease.
- Be careful not to rub the oven gasket while wiping.
- Be sure the light bulbs and glass covers are in place.
- Turn on the ventilator hood above the range and leave it on until the oven has completed the Self-Clean cycle.

IMPORTANT:

For the first Self-Cleaning cycle of your new range, remove small animals and birds from the kitchen and surrounding areas. Open a nearby window for additional ventilation.

Lock

When the CLEAN cycle starts, the automatic door lock cycle begins. The temperature gauge begins to move to CLEAN five minutes after the clean mode is initiated. Check the door to confirm that it is locked. You can stop the clean cycle by selecting the OFF position.

Make certain that the oven door is locked at the beginning of the cleaning cycle.

Prevention of Successive Self-Clean Cycles

The ovens are programmed to prevent initiation of a second Self-Clean cycle for a period of 24 hours. All of the other functions are available immediately after completion of Self-Clean.

To Set Self-Clean

1. **Remove oven racks.**
2. Ensure oven door is shut.
3. Select SELF CLEAN using the Mode Selector Ring, which surrounds the Temperature Selector Knob.
4. Set Temperature Selector Knob to CLEAN.
 - Oven latch moves to secure the door.
 - Cooling Blower turns on.
 - The temperature indicator moves to CLEAN after five minutes.

Note:

The door closing process takes approximately 20 seconds to complete, at which time the door becomes locked.

Check to make certain the door is locked.

At the End of the Clean Cycle

The CLEAN cycle takes approximately 2 hours to complete. **DO NOT** turn either of the oven control knobs to the OFF position until the automatic lock cycles to the open position.

1. Select OFF using the Mode Selector Ring to OFF.
 - The door latch will open automatically when the oven is below 500°F (200°C) and the automatic Door Lock completes its 20-second cycle to the open position.
 - The cooling blower turns off when the oven temperature drops to 375°F (190°C).
2. Turn Temperature Selector Knob to OFF position.

Cleaning Hints

1. The porcelain enamel finish is acid resistant, but not acid proof. Acidic foods, such as citrus juices, tomatoes, rhubarb, vinegar, alcohol, and milk, should be wiped up and not allowed to bake onto the porcelain during the next use.
2. **Remove the oven racks.** See Racks, on Range Cleaning Recommendations, page 79.
3. **The heating elements in the oven do not require cleaning;** the elements burn themselves clean when the oven is in use. Both elements are permanently connected. It is not necessary to clean the broiler shield above the broil element.



CAUTION:

The interior of the oven will still be at baking temperatures when the automatic lock cycles to its open position and the oven door can be opened.

Cleaning the Cooktop and the Range Exterior

When Cleaning This Range:

1. Use the mildest cleaning procedure that will do the job efficiently and effectively. Some cleaners of the same type are harsher than others. Try on a small area first.
2. **ALWAYS** rub metal finishes in the direction of the polish lines for maximum effectiveness and to avoid marring the surface.
3. Use only clean soft cloths, sponges, paper towels, fibrous brushes, plastic, non-metal or steel wool soap pads for cleaning and scouring, as recommended on the chart.
4. Most exterior parts of this appliance can be cleaned with hot sudsy water (except the various items specifically identified otherwise). When rinsing is required, rinse thoroughly.
5. **ALWAYS** wipe dry immediately to avoid water marks.



CAUTION:

Avoid cleaning any part of the range while it is hot.

Brand Names

The use of brand names is intended only to indicate a type of cleaner. This does not constitute an endorsement. The omission of any brand name cleaner does not imply its adequacy or inadequacy. Many products are regional in distribution and can be found in local markets. It is imperative that every cleaning product be used in strict accordance with the instructions on its package. The following chart gives directions for cleaning this range.

Cleaning Recommendations

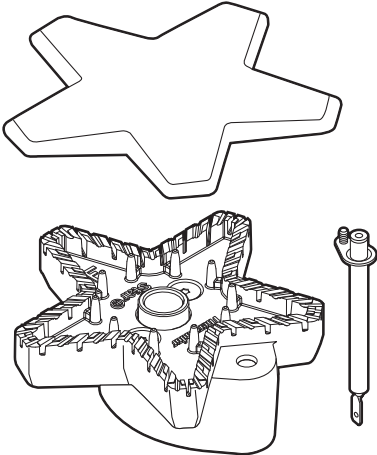
PART/MATERIAL	SUGGESTED CLEANERS	IMPORTANT REMINDERS
<p>Brass STAR® Burner Base and Cast Iron Cap</p> 	<ul style="list-style-type: none"> • Hot sudsy water; rinse and dry thoroughly. • Mild abrasive cleansers: Bon-ami®, Cameo® Aluminum and Stainless Steel Cleaner, Wright's® All Purpose Brass Polish. • Liquid cleaners: Kleen King®. • Stiff nylon bristle tooth brush to clean port openings. • After cleaning, make sure that the STAR burner cap is correctly seated on the STAR burner base. 	<ul style="list-style-type: none"> • DO NOT scratch or gouge the port openings of STAR burner cap.
<p>Control Knobs/ Metal Bezels/Chrome</p>	<ul style="list-style-type: none"> • Hot sudsy water; rinse and dry immediately. 	<ul style="list-style-type: none"> • DO NOT soak knobs. • DO NOT force knobs onto wrong valve shaft.
<p>Exterior Finish/ Back Guard Stainless Steel</p>	<ul style="list-style-type: none"> • Nonabrasive cleaners: hot water and detergent, ammonia, Fantastik®, Formula 409®. Rinse and dry immediately. • Cleaner polish: Stainless Steel Magic® to protect the finish from staining and pitting; enhances appearance. • Hard water spots: household vinegar. • Mild Abrasive Cleaners: Siege® Stainless Steel and Aluminum Cleaner, Kleen King® Stainless Steel liquid cleaner. • Heat discoloration: Cameo®, Barkeepers Friend®, Zud®, Wright's® All Purpose Brass Polish. 	<ul style="list-style-type: none"> • Stainless steel resists most food stains and pit marks providing the surface is kept clean and protected. • NEVER allow food stains or salt to remain on stainless steel for any length of time. • Rub lightly in the direction of polish lines. • Chlorine or chlorine compounds in some cleaners are corrosive to stainless steel. Check ingredients on label.

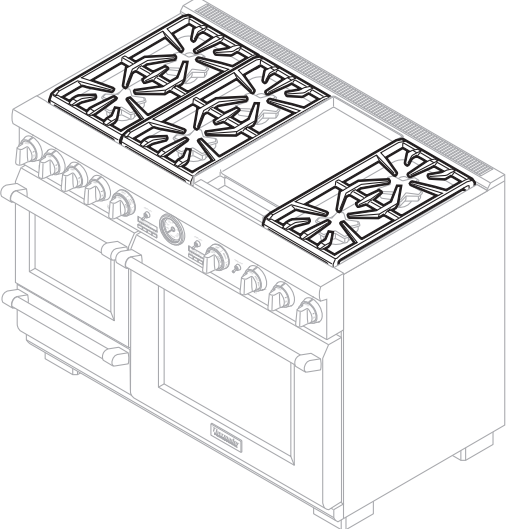
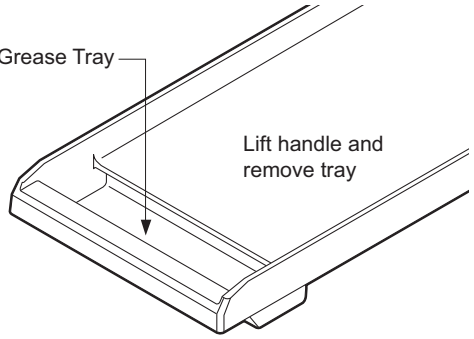
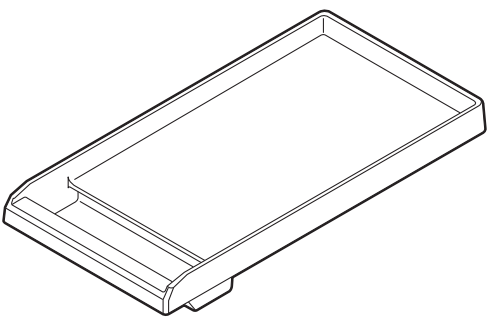
PART/MATERIAL	SUGGESTED CLEANERS	IMPORTANT REMINDERS
<p>Grates/ Porcelain Enamel on Cast Iron</p> 	<ul style="list-style-type: none"> • Nonabrasive cleaners: hot water and detergent, Fantastik[®], Formula 409[®]. Rinse and dry immediately. • Mild abrasive cleaners: Bon-ami[®] and Soft Scrub[®]. • Abrasive cleaners for stubborn stains: soap-filled steel wool pad. • Lestoil[®] or other degreaser. 	<ul style="list-style-type: none"> • The grates are heavy; use care when lifting. Place on a protected surface. • Blisters/ crazing/ chips are common due to the extreme temperatures on grate fingers and rapid temperature changes. • Acidic and sugar-laden spills deteriorate the enamel. Remove soil immediately. • Abrasive cleaners, used too vigorously or too often can eventually mar the enamel.
<p>Griddle Grease Tray/ Aluminum with non-stick titanium coating</p> 	<ul style="list-style-type: none"> • Remove grease tray and discard grease into a grease resistant container for disposal. Wash grease tray in warm soapy water or place in dishwasher. • Clean the grease tray after each use. • Wash in detergent and hot water; rinse and dry. • Stubborn soil: Soft Scrub[®]. 	<ul style="list-style-type: none"> • Empty grease tray after each use. • Remove tray after grease has cooled. Be careful not to fill it so full that tipping to remove it spills the grease.
<p>Griddle/ Aluminum with non-stick titanium coating</p> 	<ul style="list-style-type: none"> • Wipe griddle surface with warm soapy water then rinse with warm water. Wipe dry with a soft cloth. • If food particles stick to the griddle plate, remove with a mild abrasive cleaner such as Soft Scrub[®]. 	<ul style="list-style-type: none"> • NEVER flood a hot griddle with cold water. This can warp or crack the aluminum plate. • DO NOT clean any part of the grill or griddle in a self-cleaning oven.
<p>Igniters/ Ceramic</p>	<ul style="list-style-type: none"> • Use a cotton swab dampened with water, Formula 409[®] or Fantastik[®]. 	<ul style="list-style-type: none"> • DO NOT use sharp tools to scrape the igniters. The igniters are fragile. If an igniter is damaged, it may not light the STAR[®] burner.

PART/MATERIAL	SUGGESTED CLEANERS	IMPORTANT REMINDERS
Warming Drawer Interior/ Polished stainless steel	<ul style="list-style-type: none"> Use dish detergent. Wash, rinse well, and dry. For hard water spots or scale, use white vinegar. Apply with a sponge or cloth, rinse, and dry. Heat discoloration/corrosion: Clean with Bar Keeper's Friend® sprinkled on a wet sponge or wet cloth and applied to the wet stainless steel surface. Rub gently and evenly in the direction of the grain. Rinse and dry. 	<ul style="list-style-type: none"> None
Warming Drawer/ Glass	<ul style="list-style-type: none"> Use hot soapy water or mild cleaners such as Fantastik® or Formula 409®. Wash, rinse well and dry. Avoid using abrasive cleaning agents, steel wool pads and oven cleaners. 	<ul style="list-style-type: none"> None
Warming Drawer Exterior Frame/ Brushed stainless steel	<ul style="list-style-type: none"> Always wipe or rub in the direction of the grain. Clean with a soapy sponge, then rinse and dry, or wipe with Fantastik® or Formula 409® sprayed on a paper towel. Protect and polish with Stainless Steel Magic® and a soft cloth. Remove water spots with a cloth dampened with white vinegar. 	<ul style="list-style-type: none"> None
Warming Drawer Control	<ul style="list-style-type: none"> Clean with hot soapy water or apply Fantastik® or Formula 409® to a clean sponge or paper towel and wipe clean. Avoid using abrasive cleaners and scrubbing pads. 	<ul style="list-style-type: none"> None
Porcelain Enamel Spill Trays	<ul style="list-style-type: none"> A cleaner such as Soft Scrub® may be used. Apply with a damp sponge or cloth according to the manufacturer's instructions. Rinse thoroughly and wipe dry with a soft cloth. If cleaners such as Bar Keeper's Friend®, Bon-ami®, Comet® or Ajax® are used, apply with a damp sponge or cloth according to the manufacturer's directions. Rub lightly as these cleansers may scratch the finish. Rinse thoroughly and wipe dry with a soft cloth. For burned on foods, soap filled fiber or steel wool pads such as S.O.S.® or Brillo® may be used. Dampen the pad and rub gently. Care must be taken as these may scratch the finish. Rinse thoroughly and wipe dry with a soft cloth. 	<ul style="list-style-type: none"> None

PART/MATERIAL	CLEANING PRODUCTS/DIRECTIONS
Broil Pan Grid/ Bottom Porcelain Enamel	<p>To loosen cooked on food, sprinkle empty hot grid and/or bottom with powdered laundry detergent or squirt with liquid detergent and cover with wetpaper towels. Allow to stand.</p> <p>Hot sudsy water.</p> <ul style="list-style-type: none"> Wash, rinse thoroughly and dry. <p>Cleaners: Soft Scrub®.</p> <ul style="list-style-type: none"> Apply with a damp sponge or cloth according to manufacturer's directions. Rinse and wipe dry. <p>Powdered Cleanser: Bon-ami®, Comet®, Ajax®.</p> <ul style="list-style-type: none"> Apply with a damp sponge or cloth according to manufacturer's directions. Rub lightly, it may scratch the finish. Rinse thoroughly and wipe dry. <p>Soap-filled fiber or steel wool pads: S.O.S.®, Brillo®.</p> <ul style="list-style-type: none"> Dampen pad, rub lightly, it may scratch the finish. Rinse thoroughly and wipe dry.
Cavity Porcelain Enamel on Steel	<p>Porcelain enamel is acid resistant, but not acid proof. Acid foods such as citrus juices, tomatoes, rhubarb, vinegar, alcohol or milk, should be wiped up and not allowed to bake onto the porcelain during the next use. Over a period of time, the porcelain may craze (get fine hairlike lines) This will not affect oven performance.</p>
Main Oven	<p>See Self-Cleaning Instructions, page 77.</p> <p>Note:</p> <p>Due to the high temperature used for self-cleaning, the oven may develop fine hairlike lines or surface roughness. This is a common condition and does not affect either the cooking or the cleaning performance of the oven.</p>
Steam Oven	<p>See Steam Oven Cleaning and Maintenance, page 86.</p>
Front Frame Stainless Steel	<p>See Exterior Finish/Back Guard, page 79.</p>

PART/MATERIAL	CLEANING PRODUCTS/DIRECTIONS
<p>Oven Racks and Rack Guides Nickel Plated</p> <p>Note: The rack guides are removable, for cleaning using this procedure (see removal instructions on page 87).</p>	<p>Hot sudsy water.</p> <ul style="list-style-type: none"> Wash, rinse thoroughly, and dry. <p>Cleaners: Soft Scrub®.</p> <ul style="list-style-type: none"> Apply with a damp sponge or cloth according to manufacturer's directions. Rinse and wipe dry. <p>Powdered Cleanser: Bon-ami® Comet®, Ajax®.</p> <ul style="list-style-type: none"> Apply with a damp sponge or cloth according to manufacturer's directions. Rub lightly. Rinse thoroughly and wipe dry. <p>Soap filled fiber or steel wool pads: S.O.S.®, Brillo®.</p> <ul style="list-style-type: none"> Dampen pad, rinse thoroughly, and dry. <p>Harsh Cleaners: Easy Off® Oven Cleaner.</p> <p>Note: Some commercial oven cleaners cause darkening and discoloration. Test the cleaner on a small part of the rack and check for discoloration before cleaning the entire rack.</p> <ul style="list-style-type: none"> Apply a generous coating. Allow to stand for 10 to 15 minutes. Rinse thoroughly and wipe dry. <p>If the racks do not slide easily after being cleaned, dampen a paper towel with a small amount of cooking oil and rub it lightly over the siderails.</p>
<p>Doors Exterior, Frame, Handle, Heat Deflector Stainless Steel</p>	<p>Use care to keep cleaners and water away from the door vents. If water or cleaners spill into the vents, water may streak the glass inside. See Exterior Finish/Back Guard / Stainless Steel, page 79.</p>
<p>Interior Porcelain Enamel</p>	<p>See Cavity, page 82.</p>
<p>Seal Door Gasket</p>	<p>General Kitchen Cleaners: Formula 409®, Fantastik®.</p> <ul style="list-style-type: none"> Spray on and blot dry with a cloth. Do not rub. Do not move, remove or damage mesh.

Do-It-Yourself Maintenance

Replacing the Light Bulbs



CAUTION:

- Make sure the appliance and lights are cool and power to the appliance has been turned off before replacing the light bulb(s). Failure to do so could result in electrical shock or burns.
- The covers must be in place when using the appliance.
- The covers serve to protect the light bulb from breaking.
- The covers are made of glass. Handle carefully to avoid breaking. Broken glass could cause an injury.
- The light socket is live when the door is open.

Replace only with a recommended light bulb designed for appliance oven use. **DO NOT USE** a standard household light bulb in any oven. Call THERMADOR® Customer Care Center at 800-735-4328 or your nearest THERMADOR dealer to determine the proper replacement bulb for your range. You will need to know your range's serial number.

To Replace the Main Oven Light Bulb:

Use only 10 Watt, 12 Volt bi-pin halogen light bulbs. Use a clean, dry cloth to handle halogen light bulbs. This will increase the life of the bulb.

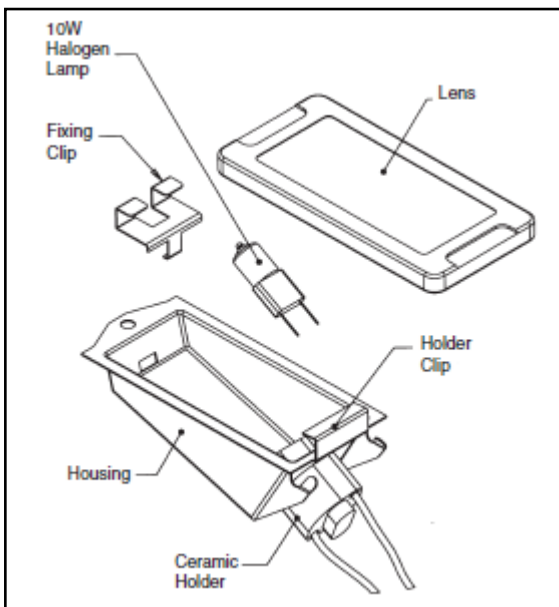

1. Turn off power to the appliance at the main power supply (breaker box) or unplug the power cord.
2. Remove oven racks.
3. Slide the tip of a flat blade screw driver between the fixing clip and the lamp housing.



Slide screw driver tip here .
Loosen glass lens cover and remove .

4. Support the glass lens cover with two fingers along the bottom edge to prevent the cover from falling to the bottom of the oven.
5. Gently twist the flat blade screw driver to loosen the glass lens cover.
6. Remove the glass lens cover and fixing clip.
7. Remove the bulb by grasping and sliding the bulb straight back until the two prongs have cleared the ceramic holder.
8. Do not touch the glass of the new replacement bulb with your fingers. It may cause the bulb to fail when it first lights. Grasp the replacement bulb with a clean dry cloth. Locate the two prongs in the ceramic holder, gently poking until the two prongs locate in the ceramic socket.
9. Press down to seat the bulb.
10. Slide the protective lens into the holder clip and push the other end until the fixing clip snaps back into the housing.
11. Reconnect the appliance to power and reset the clock.

To Replace the Steam Oven Light Bulb

Heat-resistant 120V / 25 Watt halogen bulbs with seals can be purchased through retail stores or customer service. When purchasing through customer service provide the appliance model and serial numbers.

1. Turn off power to the appliance at the main power supply (breaker box) or unplug the power cord.
2. Turn the cover to the left to remove.
3. Remove the bulb and replace with the same type of bulb.
4. Slip the new seals and tension ring onto the glass cover.

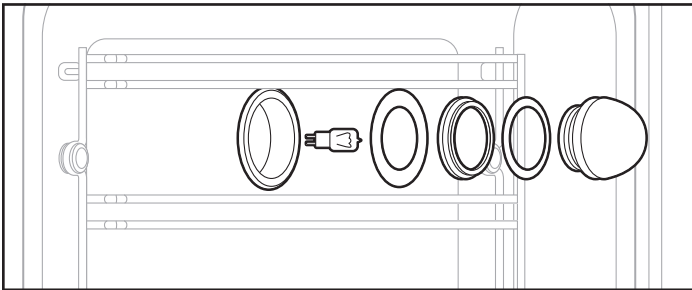

5. Screw the glass cover with seals back on.
6. Reconnect the appliance to power and reset the clock.

Never operate the appliance without the glass cover or seals.

Replacing the Glass Cover or Seals

Damaged glass covers or seals must be replaced. Provide customer service with the appliance model and serial numbers.

Intermittent or Constant Igniter Sparking

Intermittent or constant sparking of the sealed gas surface STAR burners can result from a number of preventable conditions. Eliminate these conditions as indicated in the following chart.

SYMPTOM	CAUSE	REMEDY
Intermittent sparking	<ul style="list-style-type: none"> • Ceramic igniter is wet or dirty. • STAR burner ports are clogged. 	<ul style="list-style-type: none"> • Carefully dry or clean igniter. • Clean ports on STAR burner cap with a wire, a needle or straightened paper clip.
More than four clicks of igniter before lighting	<ul style="list-style-type: none"> • Improper fit of STAR burner cap onto STAR burner base. 	<ul style="list-style-type: none"> • Align STAR burner cap properly on STAR burner base.
Constant Sparking	<ul style="list-style-type: none"> • Range is not properly grounded. 	<ul style="list-style-type: none"> • Refer to Installation Instructions. Have a qualified electrician ground the range properly.
	<ul style="list-style-type: none"> • Electrical power supply is incorrectly polarized. 	<ul style="list-style-type: none"> • Refer to the Installation Manual. Have a qualified electrician ground the range properly.

Power Failure

In the event of a power failure, only the non ExtraLow[®] burners (see page 19 for burner layout) can be lit manually. It is necessary to light each standard STAR[®] burner individually.

If the range's cooktop is being used when the power failure occurs, turn all of the STAR burner control knobs to the OFF position. The standard STAR burners can be lit

by holding a match at the ports and turning the control knob to the HI position. Wait until the flame is burning all the way around the STAR burner cap before adjusting the flame to the desired height.

The four ExtraLow STAR burners on the outer sides cannot be used during a power failure. Be sure to turn them OFF if a power failure occurs because they will not turn back on until the control knobs are turned OFF and then turned back on again. See "WHAT TO DO IF YOU SMELL GAS" on page 3.

If you have low gas pressure, contact your gas company.

Steam Oven Cleaning and Maintenance

Important:

Never use abrasives to clean the steam oven.

Remove all traces of cleaners used in the steam oven by carefully following all instructions for wiping out the oven and running rinse cycles. Cleaner residues can bond to the glass in the oven door. They can also adversely affect the flavor of foods cooked in the steam oven.

Never use steel wool or abrasive pads to clean the steam oven. The oven cavity can rust if not properly cared for.

Steam Cleaning

Steam cleaning uses steam to help dissolve food residue and spills in the oven so that they can be easily wiped up. Steam cleaning includes an exposure phase at 212°F (100°C), a cleaning phase at cooler temperatures, and two rinse cycles. Steam cleaning requires a total time of 30 – 35 minutes.

You can start STEAM CLEAN only when the oven is set to OFF and is completely cooled down. Operation of the appliance will be blocked if Steam Clean is canceled. The appliance cannot be operated again until after the first and second cleaning cycle to ensure that no cleaning agent remains inside.

Cleaning Phase

1. Let the oven cool down and remove any accessories.
2. Using the cleaning sponge provided with the oven (or a comparable soft sponge or cloth), clean the evaporator dish.
3. Fill the water tank to MAX.
4. Add a drop of dishwashing liquid to the evaporator dish.
5. On the display, under the SETTINGS menu, scroll with the “+/-” buttons to STEAM CLEAN and press “ENTER”. The display will then show START STEAM CLEAN? YES. Press ENTER again.

Note:

Toggle with the “+/-” buttons gives the option START STEAM CLEAN? NO. If you press “ENTER” when the display shows START STEAM CLEAN? NO, the display returns to the previous menu, showing STEAM CLEAN under the SETTINGS menu.

6. Press “ENTER” to begin steam cleaning. The display will show EXPOSURE PHASE on the first line and exposure time of 10 minutes on the second line. The display will start counting down from 10:00 to 0:00. The display will then show CLEANING PHASE and a total time of 20 minutes. Countdown from 20:00 to 0:00 will begin.

At the end of the cleaning phase (about 30 minutes), the countdown will be suspended and a buzzer will sound. The display will show CLEAN DISH on the first line and PRESS ENTER BUTTON on the second line. **DO NOT** press ENTER before following the instructions below.

First Rinse Cycle

1. Remove the rack rails from the oven and clean softened food residues from them (see “Cleaning the Rack Rail Frames” on page 87).
2. Using a **soft** dishwashing brush and the cleaning sponge, wipe out the partly dissolved food residues from the oven and the evaporator dish. Thoroughly wash out the cleaning sponge.
3. Check the water tank, refill it, and slide it back in.
4. Press “ENTER” to start the first rinse cycle. The display will show 1ST RINSE on the first line. The countdown will resume, and after a short time (about 20 seconds), a beep will signal the end of the first rinse. The display will show CLEAN DISH on the first line and PRESS ENTER BUTTON on the second line.
5. Using the cleaning sponge, wipe out the evaporator dish. Thoroughly rinse out the cleaning sponge.

Second Rinse Cycle

1. Press “ENTER” to start the second rinse cycle. The display will show 2ND RINSE on the first line. The countdown will resume, and after another 20 seconds a beep will signal the end of STEAM CLEAN. The display will show STEAM CLEAN FINISHED on the first line and CLEAN DISH on the second line.
2. Using the cleaning sponge, wipe any remaining water from the evaporator dish, and wipe down the oven. Thoroughly rinse out the cleaning sponge.
3. Using a soft cloth, dry the oven cavity.

Descaling the Steam Oven

Unless you use softened water, you will need to descale the steam oven at regular intervals. Once you have set your water hardness level (see page 49), the steam oven display will automatically inform you when descaling is needed. Descaling includes an exposure, two descaling phases, and two rinse cycles, with a total time of 30-35 minutes.

Water Hardness	Operation Hour Counter
1 – softened	unlimited, no message
2 – soft	400 hours
3 – medium	200 hours
4 – hard	100 hours
5 – very hard	70 hours

If the number of hours of operation is exceeded, the DESCALING message will be displayed each time when a new heating mode is selected. Select ENTER to continue. After the Descaling operation is finished, the operation hour counter will be reset and the message will no longer be displayed.

You can start DESCALING only when the oven is set to OFF and is completely cooled down. Once descaling begins, it should not be interrupted. It is very important that all rinse cycles are completed.

Descaling Phase

- Using only the descaling powder recommended for this oven (BSH part number 573828; obtain from your retailer or order from <http://www.thermador-eshop.com>), mix 32 oz. (1 quart or 0.95 liter) of water with a packet of powder descaler to produce the descaling solution.
- Empty the water tank and refill it with the descaling solution. On the display, under the SETTINGS menu, scroll with the “+/-” buttons to DESCALING and press “ENTER”. The display will then show START DESCALING? YES”.

Note:

Toggle with the “+/-” buttons gives the option START DESCALING? NO. If you press “ENTER” when the display shows START DESCALING? NO, the display returns to the previous menu, showing DESCALING under the SETTINGS menu.

- Press “ENTER” to begin descaling. The display will show EXPOSURE PHASE on the first line and 10:00 on the second line, and the countdown to 0:00 begins. At this point DESCALING PHASE is displayed, and with a time of 20 minutes.

At the end of the descaling phase, the countdown is suspended and a beep will sound. The display will show CLEAN DISH, FILL TANK on the first line and AND WIPE OUT OVEN on the second line.

First Rinse Cycle

- Remove the water tank and wash it out thoroughly, fill it with water and slide it back in.
- Using the cleaning sponge provided with your range (or a comparable soft cloth or sponge), wipe any water out of the evaporator dish and wipe out the oven. Thoroughly wash out the cleaning sponge.
- The display will now show PRESS ENTER BUTTON. Press “ENTER” to start the first rinse cycle. The display will show 1ST RINSE on the first line. The countdown will resume.
- After 20 seconds, a beep will signal the end of the first rinsing cycle. The display will show CLEAN DISH on the first line and PRESS ENTER BUTTON on the second line.
- Using the cleaning sponge, wipe any water out of the evaporator dish.

Second Rinse Cycle

- Press “ENTER” to start the second rinse cycle. The display will show 2ND RINSE on the first line. The countdown will resume again.
- After 20 seconds, a beep will signal the end of DESCALING. The display will show DESCALING FINISHED on the first line and CLEAN DISH on the second line.
- Using the cleaning sponge, wipe any water out of the evaporator dish and wipe out the oven. Thoroughly rinse out the cleaning sponge.
- Using a soft cloth, dry the oven cavity.

Cleaning the Rack Rail Frames

The rack rail frames can be removed for cleaning.

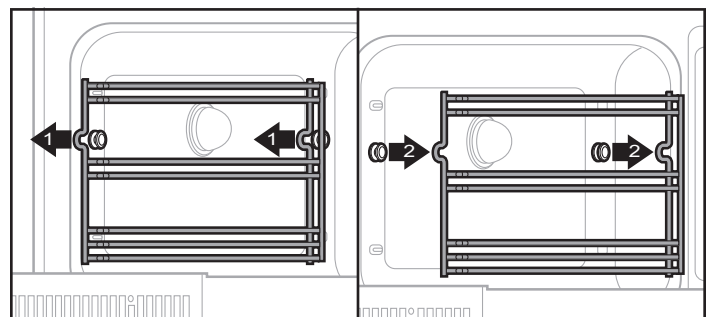

Pull the rack rail frame toward you and remove. Use dishwashing soap and a kitchen sponge or brush to clean the rack rail frames. The rack rail frames can also be washed in the dishwasher.

Installing the Rack Rail Frames

Hang the back and front parts of the frame and then push it back until it locks into place.

Each rack rail frame only fits on one side.

Before Calling For Service

Before calling for service, check the following to avoid unnecessary service charges.

Be sure to check these items first:

- Is there a power outage in the area?
- Is the household fuse blown or the circuit breaker tripped?
- Is the range disconnected from the electrical supply?

If the STAR® Burners DO NOT Ignite:

- Are the STAR burner caps properly aligned and seated in the STAR burner bases?
- Are the STAR burner ports clogged?
- Is a fuse blown or is the circuit breaker tripped?
- Is the manual shut-off valve closed, preventing the flow of gas?

Data Rating Label

The data rating label shows the model and serial number of your range. It is located in the gap created by the right side of the oven cavity and the range side panel.

The electric wiring diagrams and schematics are attached behind the door trim, and should not be removed except by a service technician, then replaced after service.

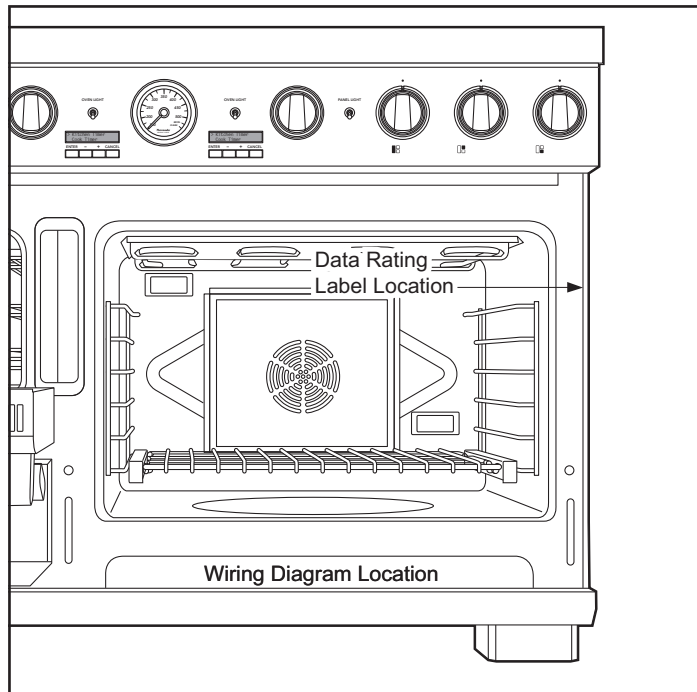

Figure 1: Rating Label Location

Service Information

For handy reference, copy the information in the form below from the data rating plate located in the gap created by the right side of the oven cavity and the range side panel. Keep your invoice for Warranty validation.

Model Number _____

Serial Number _____

Date of Purchase _____

Dealer's Name _____

Dealer's Phone Number _____

Service Center's Name _____

Service Center's Phone Number _____

Also, enter this information on the Product Registration Form included with this product, then mail it to the indicated address.

Statement of Limited Product Warranty

What this Warranty Covers & Who it Applies to

The limited warranty provided by BSH Home Appliances Corporation in this Statement of Limited Product Warranty applies only to the THERMADOR® appliance sold to you, the first using purchaser, provided that the Product was purchased:

- For your normal, household (non-commercial) use, and has in fact at all times only been used for normal household purposes.
- New at retail (not a display, “as is”, or previously returned model), and not for resale, or commercial use.
- Within the United States or Canada, and has at all times remained within the country of original purchase.

The warranties stated herein apply only to the first purchaser of the Product and are not transferable.

Please make sure to return your registration card; while not necessary to effectuate warranty coverage, it is the best way for THERMADOR to notify you in the unlikely event of a safety notice or product recall.

How Long the Warranty Lasts

THERMADOR warrants that the Product is free from defects in materials and workmanship for a period of seven hundred thirty (730) days from the date of purchase. The foregoing timeline begins to run upon the date of purchase, and shall not be stalled, tolled, extended, or suspended, for any reason whatsoever.

Repair/Replace as Your Exclusive Remedy

During this warranty period, THERMADOR or one of its authorized service providers will repair your Product without charge to you (subject to certain limitations stated herein) if your Product proves to have been manufactured with a defect in materials or workmanship. If reasonable attempts to repair the Product have been made without success, then THERMADOR will replace your Product (upgraded models may be available to you, in the sole discretion of THERMADOR, for an additional charge). All removed parts and components shall become the property of THERMADOR at its sole option. All replaced and/or repaired parts shall assume the identity of the original part for purposes of this warranty and this warranty shall not be extended with respect to such parts. The sole liability and responsibility of THERMADOR hereunder is to repair manufacturer-defective Product only, using a THERMADOR-authorized service provider during normal business hours. For safety and property damage concerns, THERMADOR highly recommends that you do not attempt to repair the Product yourself, or use an unauthorized

servicer; THERMADOR will have no responsibility or liability for repairs or work performed by a non-authorized servicer. If you choose to have someone other than an authorized service provider work on your Product, THIS WARRANTY WILL AUTOMATICALLY BECOME NULL AND VOID. Authorized service providers are those persons or companies that have been specially trained on THERMADOR products, and who possess, in the opinion of THERMADOR, a superior reputation for customer service and technical ability (note that they are independent entities and are not agents, partners, affiliates or representatives of THERMADOR). Notwithstanding the foregoing, THERMADOR will not incur any liability, or have responsibility, for the Product if it is located in a remote area (more than 100 miles from an authorized service provider) or is reasonably inaccessible, hazardous, threatening, or treacherous locale, surroundings, or environment; in any such event, if you request, THERMADOR would still pay for labor and parts and ship the parts to the nearest authorized service provider, but you would still be fully liable and responsible for any travel time or other special charges by the service company, assuming they agree to make the service call.

Out of Warranty Product

THERMADOR is under no obligation, at law or otherwise, to provide you with any concessions, including repairs, pro-rates, or Product replacement, once this warranty has expired.

Warranty Exclusions

The warranty coverage described herein excludes all defects or damage that are not the direct fault of THERMADOR, including without limitation, one or more of the following:

- Use of the Product in anything other than its normal, customary and intended manner (including without limitation, any form of commercial use, use or storage of an indoor product outdoors, use of the Product in conjunction with air or water-going vessels).
- Any party's willful misconduct, negligence, misuse, abuse, accidents, neglect, improper operation, failure to maintain, improper or negligent installation, tampering, failure to follow operating instructions, mishandling, unauthorized service (including self-performed “fixing” or exploration of the appliance's internal workings).
- Adjustment, alteration or modification of any kind.

- A failure to comply with any applicable state, local, city, or county electrical, plumbing and/or building codes, regulations, or laws, including failure to install the product in strict conformity with local fire and building codes and regulations.
- Ordinary wear and tear, spills of food, liquid, grease accumulations, or other substances that accumulate on, in, or around the Product.
- Any external, elemental and/or environmental forces and factors, including without limitation, rain, wind, sand, floods, fires, mud slides, freezing temperatures, excessive moisture or extended exposure to humidity, lightning, power surges, structural failures surrounding the appliance, and acts of God.

In no event shall THERMADOR® have any liability or responsibility whatsoever for damage to surrounding property, including cabinetry, floors, ceilings, and other structures or objects around the Product. Also excluded from this warranty are scratches, nicks, minor dents, and cosmetic damages on external surfaces and exposed parts; Products on which the serial numbers have been altered, defaced, or removed; service visits to teach you how to use the Product, or visits where there is nothing wrong with the Product; correction of installation problems (you are solely responsible for any structure and setting for the Product, including all electrical, plumbing or other connecting facilities, for proper foundation/flooring, and for any alterations including without limitation cabinetry, walls, floors, shelving, etc.); and resetting of breakers or fuses.

TO THE EXTENT ALLOWED BY LAW, THIS WARRANTY SETS OUT YOUR EXCLUSIVE REMEDIES WITH RESPECT TO PRODUCT, WHETHER THE CLAIM ARISES IN CONTRACT OR TORT (INCLUDING STRICT LIABILITY, OR NEGLIGENCE) OR OTHERWISE. THIS WARRANTY IS IN LIEU OF ALL OTHER WARRANTIES, WHETHER EXPRESS OR IMPLIED. ANY WARRANTY IMPLIED BY LAW, WHETHER FOR MERCHANTABILITY OR FITNESS FOR A PARTICULAR PURPOSE, OR OTHERWISE, SHALL BE EFFECTIVE ONLY FOR THE PERIOD THAT THIS EXPRESS LIMITED WARRANTY IS EFFECTIVE. IN NO EVENT WILL THE MANUFACTURER BE LIABLE FOR CONSEQUENTIAL, SPECIAL, INCIDENTAL, INDIRECT, "BUSINESS LOSS", AND/OR PUNITIVE DAMAGES, LOSSES, OR EXPENSES, INCLUDING WITHOUT LIMITATION TIME AWAY FROM WORK, HOTELS AND/OR RESTAURANT MEALS, REMODELLING EXPENSES IN EXCESS OF DIRECT DAMAGES WHICH ARE DEFINITELY CAUSED EXCLUSIVELY BY THERMADOR, OR OTHERWISE. SOME STATES DO NOT ALLOW THE EXCLUSION OR LIMITATION OF INCIDENTAL OR CONSEQUENTIAL DAMAGES, AND SOME STATES DO NOT ALLOW LIMITATIONS ON HOW LONG AN IMPLIED WARRANTY LASTS, SO THE ABOVE LIMITATIONS MAY NOT APPLY TO YOU. THIS WARRANTY GIVES YOU SPECIFIC LEGAL RIGHTS, AND YOU MAY ALSO HAVE OTHER RIGHTS WHICH VARY FROM STATE TO STATE.

No attempt to alter, modify or amend this warranty shall be effective unless authorized in writing by an officer of BSH.

Register your THERMADOR product to ensure timely service and access to your product related information. You may register your product through one of the following ways:

1. Mail in the completed THERMADOR Product Registration card
2. Register your product online at thermador.com
3. Call us at THERMADOR customer service at 800-735-4328.

THERMADOR® Support

Service

We realize that you have made a considerable investment in your kitchen. We are dedicated to supporting you and your appliance so that you have many years of creative cooking.

Please don't hesitate to contact our STAR® Customer Support Department if you have any questions or in the unlikely event that your THERMADOR appliance needs service. Our service team is ready to assist you.

USA:
800-735-4328
www.thermador.com/support

Canada:
800-735-4328
www.thermador.ca

Parts & Accessories

Parts, filters, descalers, stainless steel cleaners and more can be purchased in the THERMADOR eShop or by phone.

USA:
www.thermador-eshop.com

Canada contact:
AP Wagner 800-268-7513 or

Reliable Parts 800-663-6060

Thermador  TM

REAL INNOVATION S FOR REAL COOKS TM

1901 Main Street, Irvine, CA 92614 • 800-735-4328 • www.thermador.com
9000669884 • Rev B • 5U042J • 11/11 © 2011 BSH Home Appliances Corporation