

SIEMENS



Fridge-freezer

冰箱/雪櫃

KG28US12EK

siemens-home.bsh-group.com/welcome

en Instruction for Use
zh-hk 安裝說明與使用說明

Register
your
product
online

en	Table of Contents	3
-----------	--------------------------	----------

zh-hk	目錄	24
--------------	-----------	-----------

Table of Contents

Product Introduction

Safety and warning information	4
Product features	5
Information concerning disposal	6
Handling and placing	7
Electrical connection	8
General regulations	8
Installation dimensions	9
Getting to know your appliance	10

Usage

Preparations before use	11
Control and display panel	11
Switching on the appliance	12
Setting the temperature	12
Refrigerator compartment	13
Middle compartment	14
Freezer compartment	14

Freezing capacity	15
Ice making	15
Storage period of frozen food	17

Cleaning and maintenance

Defrosting	18
Cleaning the appliance	18
Tips for saving energy	19
Miscellaneous	19

Eliminating minor faults yourself

Symptoms which are not faults	20
Analysis and exclusion of special conditions	22

Product Introduction

Safety and warning information

Before you switch ON the appliance

Please read the operating and installation instructions carefully! They contain important information on how to install, use and maintain the appliance.

Retain all document for subsequent use.

During use of this machine

- Be sure to use a separate three-way socket outlet with reliable earth.
- Avoid crushing, folding, knotting or damage of power cord. If the power cord is damaged, it must be replaced by the manufacturer or its repair department or similar staff to avoid danger. The refrigerator can be used only after the power cord is replaced, otherwise, electrical shock or fire may occur.
- When unplugging the appliance, do not directly pull at the power cord, it could be ripped off.
- The children should be kept away from playing with or climbing the refrigerator, and do not let anyone to climb, sit, stand or lean against the refrigerator door to avoid injury and damage to the refrigerator. When serving or cleaning the refrigerator, the appliance must be unplugged.
- This appliance can be used by children aged from 8 years and above and persons with reduced physical, sensory or mental

capabilities or lack of experience and knowledge if they have been given supervision or instruction concerning use of the appliance in a safe way and understand the hazards involved.

- The refrigerator is household freezer, mainly used for food storage and freezing, and not suitable for items with strict temperature requirements (such as vaccine, strains, and chemical regents).
- **Danger** - do not store or use flammable materials near the refrigerator, such as gas, paint, gasoline etc., and it's prohibited to store flammable and explosive substances such as alcohol, gasoline in the refrigerator to avoid explosion and fire.
- **Danger** - glass bottle or jar containing liquid cannot be placed in the freezer due to danger of explosion after fully freezing.
- **Danger** - do not place the refrigerator in the position where is wet and easy to splash water.
- **Danger** - do not use wet hand to touch the food or metal container in the freezer, otherwise, frostbite due to low temperature may occur.
- ▲ **Warning** - this product is household refrigerator, only suitable for storing food, and cannot be used for other purpose, such as storing blood and products, drugs, biological products and technical materials, etc.

Product Introduction

⚠ Warning - it is prohibited to damage the refrigeration line. If the cooling agent inside the tubes is splashed on the eyes, this may result in severe injury. In such an event, the eyes must be washed clean immediately and medical treatment must be sought in a hospital.

⚠ Warning - do not use the machine or other means to speed the defrosting process except the ones recommended by the company. At the same time, no electric devices other than recommended by the manufacturer may be used inside the appliance.

⚠ Warning - the electrical appliances such as microwave, electric rice cooker, voltage regulator should not be placed on or near the top of the refrigerator, and weights and container filled with water should neither be placed on the top of the refrigerator to prevent injury due to falling or electric shock and fire caused by liquid overflow resultant electricity leakage.

⚠ Warning - When flammable gas leaks, the valve of the source of leakage should be closed first, and try to discharge indoor air. In such an event, do not unplug or operate the refrigerator under any circumstances in order to avoid a fire.

⚠ Warning - in the casing or embedded structure of the refrigerator, ventilation must be kept smooth and free of obstruction.

Product features

Separate cooling system with no frost technology

Forced convection refrigeration is used in refrigerator and middle compartment, air cooling technology is used in the freezer. The refrigerator, middle compartment and freezer are all equipped with automatic defrosting. The system also equips a dynamic cooling fan and a forced refrigerating cycle so that food can be cooled down quickly and maintains a uniform temperature.

LCD temperature display

LCD displays the set temperature and function status of each compartment respectively. The design is clear and can be understood at a glance, making operating of the appliance easy.

Efficient and energy-saving

With highly efficient and energy-saving compressor and thickened foam layer, more efficient and energy-saving refrigeration is achieved.

Three separate controls for three temperatures zones

The refrigerator, the middle compartment and the freezer are controlled and displayed by computer system to achieve more precise temperature control and more long-lasting preservation.

Product Introduction

Smart super cooling, fast and convenient

The super cooling function set the temperature within the refrigerator compartment quickly to 2°C. This enhances food freshness and makes the cooling of drinks easier.

Smart super freezing for intensive freshness

The super freezing function freeze food at a temperature below -18°C as quickly as possible. This makes the preservation of freshness technologically even more reliable.

hyperFresh cooling (middle compartment)

With independent refrigeration system, cold air circulation system and moisturizing device, the internal temperature can be control at about 0°C. In this environment, the growth and reproduction of microorganisms (bacteria, yeast, mold) has been inhibited more effectively, Food can be stored up to two to three times longer than in the normal cooling zone without loss of freshness.

Quiet technology

A series of noise reduction technologies are adopted to minimize the noise.

Wide climatic zone design

Suitable for types of climate from sub-temperature and subtropical climate, with some products capable of adapting to tropical climate. See also technical parameters and packing list for specific climate types.

R600a refrigerant, a pioneer in environmental technology

The refrigerant R600a and the foaming agents are hydrocarbons which do not damage the ozone layer and do not contribute to the greenhouse effect.

Tempered glass shelf, safe and reliable

Safe and aesthetic shelves made of tempered glass, with high loading capacity and durability.

Removable door seal strip, easy to clean

Special removable door seal strip with long service life, strong adsorption, ease to clean.

Door alarm function

If the appliance is left open for a longer time, the door alarm switches on.

Temperature alarm

The temperature alarm switches on if the appliance is too warm.

Information concerning disposal

Disposal of packaging

The packaging protects your appliance from damage during transit. All utilized materials are environmentally safe and recyclable. Please dispose the packaging in an environmentally friendly manner. Please ask your dealer or inquire at your local authority about current means of disposal.

Product Introduction

⚠ Warning

Keep children away from packaging.
Danger of suffocation from folding carton and plastic film.

Disposal of your old appliance

Old appliances are not worthless rubbish! Valuable raw materials can be reclaimed by recycling old appliances.

⚠ Warning

Redundant appliances should be handled as follows:

1. Pull out the mains plug,
2. Cut off the power cord and Discard with the mains plug,
3. Dismantle the main body of the door and remove the door seal strip in order to prevent children from being trapped inside!
4. Do not allow children to play with the old appliance; Danger of suffocation!
5. Do not allow children to play with the old appliance; Danger of suffocation!

⚠ Warning

Refrigerators contain refrigerant and gases in the insulation. Refrigerant and gases must be disposed of professionally. Ensure that tubing of the refrigerant circuit is not damaged prior to proper disposal.

Handling and placing

Handling

- ⚠ Do not hold the door or door handle to move the refrigerator, and the refrigerator should be lifted from the bottom.
- ⚠ The refrigerator should not be placed horizontally or upside down.

Placing

- ⚠ Install the appliance in a dry, well ventilated room, ensure minimum lateral distance of 10cm at the both side and the back, and a gap of 30cm should be kept on the top.
- ⚠ Never cover the ventilation openings on the rear of the appliance. The installation location should neither be exposed to direct sunlight nor near a heat source.

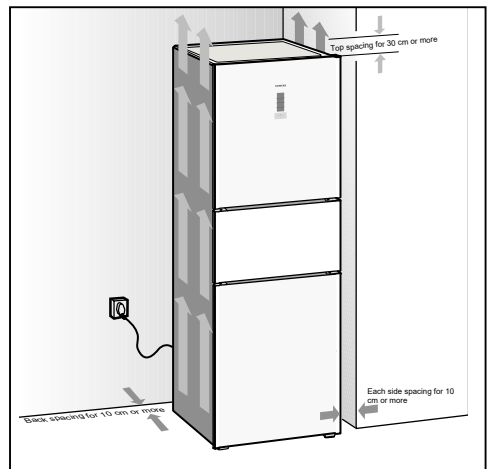

Product Introduction

Aligning the appliance

When placing the refrigerator, be sure to adjust the two front foot screws to proper height.

Place the refrigerator to a firm level. Use a wrench to adjust two plastic front feet, to keep the refrigerator vertical and steady.

Be sure to keep the plastic screws in contact with the ground and firm (to reduce vibration and noise).

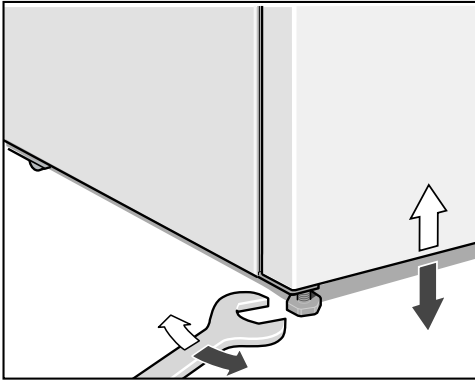

General regulations

The appliance is suitable

- for refrigerating and freezing food,
- for making ice.

This appliance is intended for use in the home and the home environment.

The appliance is suppressed according to EU Directive 2004/108/EC.

The refrigeration circuit has been checked for leaks.

This product complies with the relevant safety regulations for electrical appliances (IEC 60335-2-24).

This appliance is intended for use up to a maximum height of 2000 metres above sea level.

Electrical connection

The rated voltage of the appliance is 220V alternating current with a rated frequency of 50 Hz. The permitted voltage fluctuation ranges from 187V to 242V.

Note: refer to 15945-2008 GB/T, power quality, power system frequency deviation

The plug and the power cord must be able to withstand a current in excess of 10A.

Be sure to use a separate three-way socket outlet with reliable earth.

Product Introduction

Installation dimensions

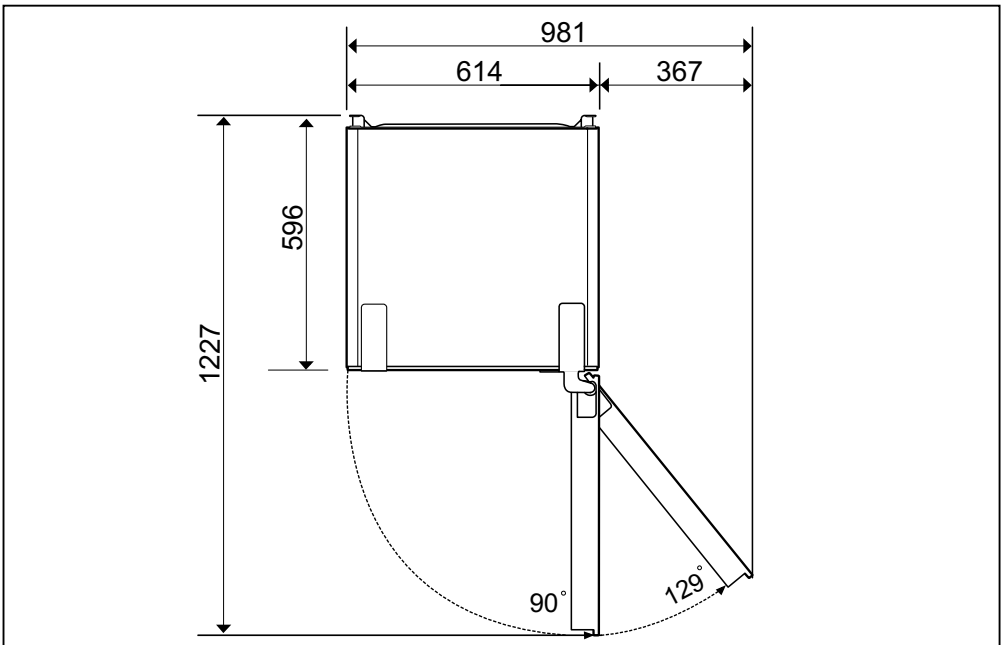
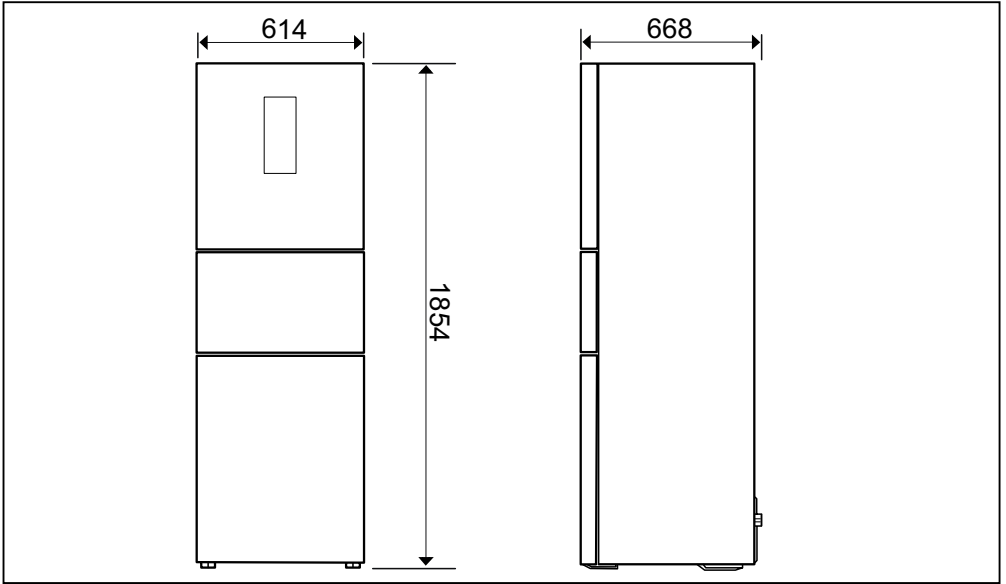

Product Introduction

Getting to know your appliance

These operating instructions refer to several models.

Each model is available in multiple options. All the illustrations in the instructions are schematic views, hence, some features and devices may vary from the illustrations, please take the product as the standard for specific structure and configuration.

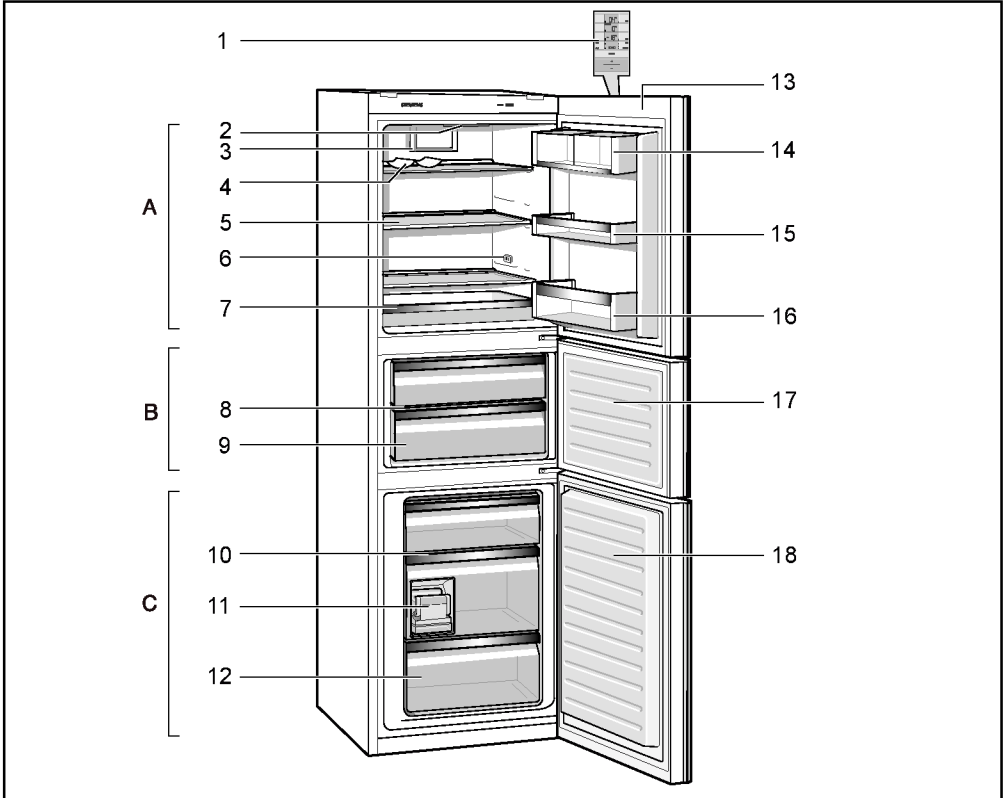

- | | | |
|---|---|----------------------------------|
| 1 Control and display panel | 7 Drawers of the refrigerator compartment | 13 Refrigerator compartment door |
| 2 Lighting (LED) | 8 Humidity filter | 14 Butter and Cheese compartment |
| 3 Fan | 9 Middle compartment drawer | 15 Shelf for small bottle |
| 4 Bottle shelf | 10 Glass shelf in freezer | 16 Shelf for big bottle |
| 5 Glass shelf in refrigerator compartment | 11 Ice maker* | 17 Middle compartment door |
| 6 Sensor | 12 Freezer drawer | 18 Freezer door |

A Refrigerator compartment

B Middle compartment

C Freezer compartment

10

* Not all models

Usage

Preparations before use

Remove all packaging components, including foamed padding at the base of the appliance and the padding and securing tapes used for securing the fittings inside the appliance.

Check the supplied fittings, accessories and documentation according to the packaging list.

Place the refrigerator to the proper position according to the handling and placing.

Clean the interior of the appliance (see chapter "Cleaning the appliance").

After switching on the appliance, wait at least 30 minutes to start up.

Control and display panel

The control panel is equipped with LCD, and all functions and temperatures are selected and adjusted by touching the buttons. The names and functions of each button are as follows.

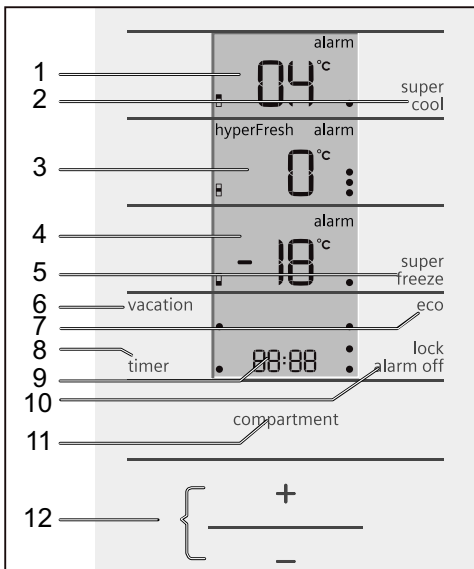

- 1 Refrigerator compartment display
Indicates the current temperature setting in the refrigerator compartment.
- 2 Super cooling button
Press button 2 to activate or deactivate the super cooling function.
Under super cooling mode, the temperature of the refrigerator is set at 2°C and keep running for 6 hours.
- 3 Middle compartment display
Indicates the current temperature setting in the middle compartment.
- 4 Freezer compartment display
Indicates the current temperature setting in the freezer compartment.
- 5 Super freezing button
Press button 5 to activate or deactivate the super freezing function.
Under super freezing mode, the temperature of the freezer is set at -30°C and keep running for 54 hours.
- 6 vacation button
When vacation mode is switched on, the appliance automatically sets at 14°C in the refrigerator compartment, middle compartment and freezer keep the set temperatures.
- 7 eco button
When the eco mode is switched on, the appliance will run in energy-saving mode.
- 8 timer button
- 9 Timer display
- 10 lock/alarm off
Keep pressing the button for 3 seconds to lock and unlock; the button is also used to switch off the alarm.
- 11 Temperature setting button
- 12 Temperature adjusting button

Usage

Switching on the appliance

When first powered on

Plug in the power cord to connect the appliance to the mains.

If displays do not illuminate, please check the mains plug whether has been inserted properly.

When the appliance is switched on, the temperature setting of refrigerator and freezer are displayed respectively (The factory settings of refrigerator compartment, middle compartment and freezer compartment are 4°C, 0°C, and -18°C respectively).

If the temperature inside the freezer exceeds the alarm temperature, “alarm” and the freezer compartment temperature will be indicated on the display and the buzzer (continuous sound) will be actuated. Press the alarm button 10 to switch the signal off again, the highest temperature reached in the freezer compartment will be displayed for 5 seconds, then the set temperature is displayed again. The “alarm” display goes out as soon as the set temperature has been reached again.

Several minutes after switching on, you may feel warm when touching both sides of the refrigerator, indicating that the refrigerating system is working.

Setting the temperature

Setting the temperature of the refrigerator compartment

Press the button 11 to activate the temperature display area 1 of the refrigerator compartment, then press the setting button "+" or "-" of the button 12 to adjust the desired temperature of refrigerator compartment (Adjustable from 2°C to 8°C).

When storing perishable food, we recommend setting the temperature below 4°C.

Setting the temperature of the middle compartment

Press the button 11 to activate the temperature display area 3 of the middle compartment, then press the setting button "+" or "-" of the button 12 to adjust the desired temperature of middle compartment (Adjustable from -3°C to 6°C).

When storing the fresh vegetables and fruit, it is recommended to set the temperature of the middle compartment at 0°C.

Usage

Setting the temperature of the freezer compartment

Press the button 11 to activate the temperature display area 4 of the refrigerator compartment, then press the setting button "+" or "-" of the touch button 12 to adjust the desired temperature of freezer compartment (Adjustable from -16°C to -24°C).

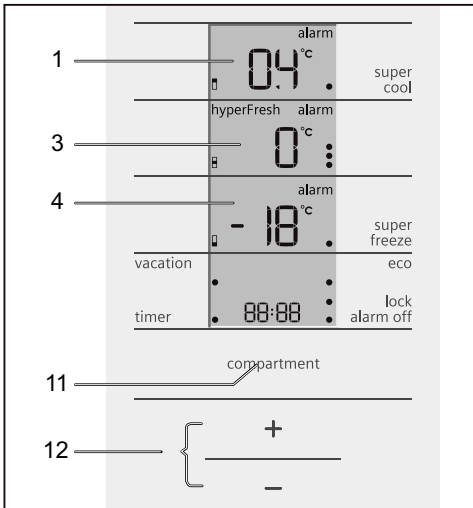

If a power failure occurs, the temperature settings do not need to reset again.

Refrigerator compartment

The refrigerator compartment is the ideal storage location for ready meals.

Glass shelf

The position of glass shelf of the refrigerator can be adjusted in order to store various kinds of food.

Pull out the glass shelf by half, and lift the front of the shelf to take out the shelf.

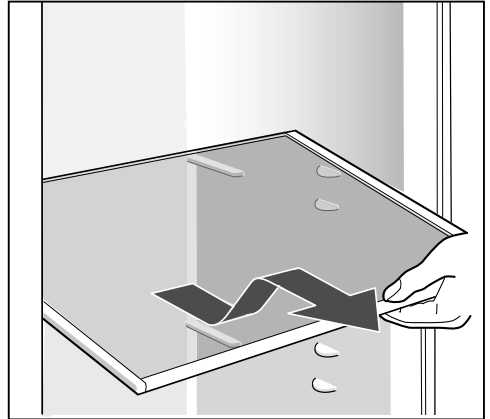

Butter and cheese compartment can store the food which needs to be separated such as cheese, and can be rearranged as required. Raise the compartment and remove.

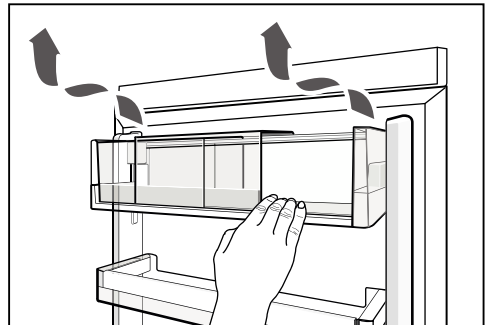

Usage

The bottle shelf on the door is used to store eggs, bottled drinks and all kinds of fragmented food.

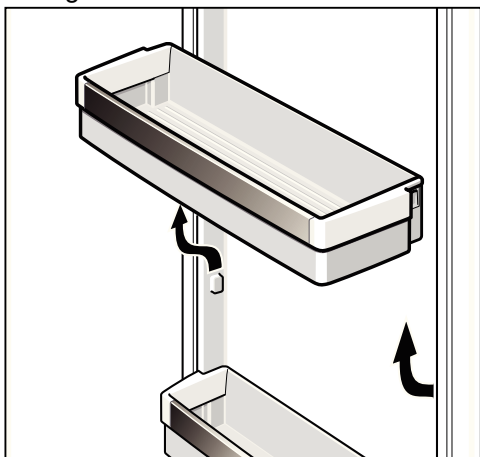

Middle compartment

The temperature of the middle compartment is between -3°C and 6°C . There are two kinds of temperature displays: when the temperature is set at 0°C , "hyperFresh" will appear; when the other temperature is displayed, no text is displayed.

Usually, the middle compartment is set as 0°C hyperFresh by default, humidity can be preserved at maximum, and the preservation period is two to three times longer than conventional preservation. This is suitable for storing fresh food, such as fish, meats, eggs, milk, fruits and vegetables.

Drawer

The middle compartment is equipped with two drawers with rails for conveniently putting in and taking out articles.

Pull out the drawer rail and the drawer together, hold the handle and lift the back end of the drawer to disengage the drawer rail and the drawer to pull out the drawer.

When mounting the drawer, first pull out the rail, put the drawer on the rail, and push in the drawer while securing the rail with hand until the drawer and rail completely engage.

Freezer compartment

The freezer compartment is mainly used to store frozen food, freeze food and make ice cubes. It can preserve the food for a longer time.

The freezer compartment is equipped with drawer, pull out the drawer and gently lift upward to take out.

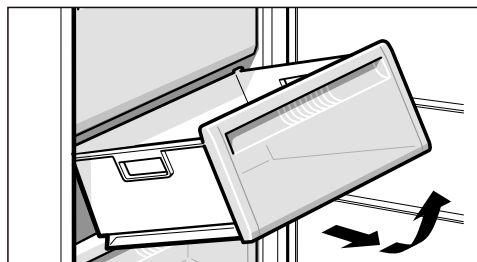

Large amount of food can be frozen and stored in the upper drawer and the middle drawer.

The lower drawer is mainly used for storing frozen food.

The freezer compartment drawers are a parts for user convenience, the drawers can be taken out and put the food on the glass shelf directly.

Usage

Note: the glass shelf may easily crack when heated, please do not store hot food on the glass shelf.

The middle drawer is used for freezing and storing food with large volume such as turkey, duck and goose. If larger space is needed, the ice maker can be removed. (not all models)

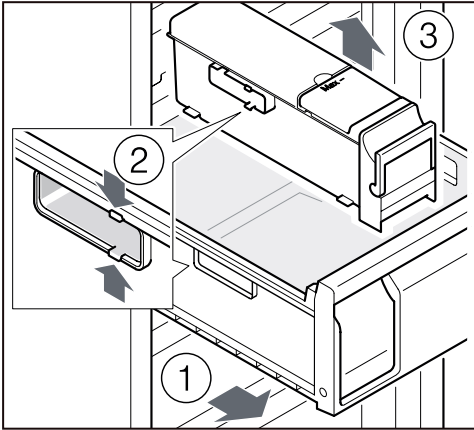

Freezing capacity

The freezing capacity marked on the rating plate. According to IEC 62552, the quantity of the resulting frozen food is tested and calculated under standard operating conditions.

Ice making

To facilitate the quick preparation of ice cubes, set the freezer compartment temperature to the lowest setting or activate the Super freezing function beforehand.

Only drinking water can be used for ice cubes making.

Fill drinking water into the ice cube tray until it is full, then place the ice cube tray horizontally into the second drawer of the freezer compartment.

Fill drinking water into the ice cube tray until it is full; excessive water may make the ice cube stick together which leads hard to loosen the ice cubes, and prolong the ice making time.

The maximum amount of ice cubes can be made is 1500 grams in 24 hours. Generally, the duration for making ice cubes at one time is approx. 3 hours.

When you want to take out the ice cubes, twist the ice cube tray slightly to release the ice cubes.

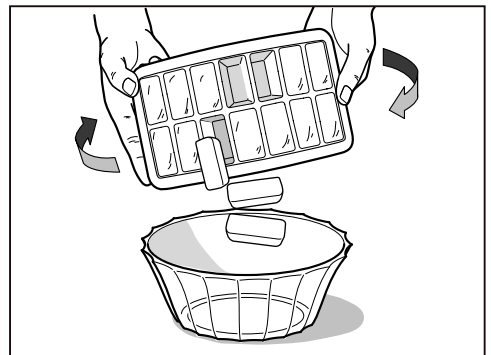

Usage

For some models equipped with ice maker, please make ice according to the followings.

To facilitate the quick preparation of ice cubes, set the freezer compartment temperature to the lowest setting or activate the Super freezing function beforehand.

Only drinking water can be used for ice cubes making.

The maximum amount of ice cubes can be made is 1000 grams in 24 hours. Generally, the duration for making ice cubes at one time is approx. 3 hours.

1. Take out the water container and fill with drinking water to the mark line.
2. Fill the drinking water into the ice maker.
3. Reinsert the water container.
4. When the ice cubes are made, push down the ice making handle, and the ice cubes will fall into the ice storing tray .
5. Pull out the ice storing tray to take out the ice cubes.

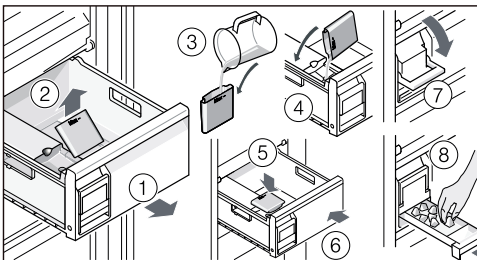

Cleaning the ice maker

Before the first use of ice maker or no use for a long time, The ice maker should be cleaned.

1. Pull out the drawer, and take out the water container and the cover on the ice maker.
2. Gently clean with running water, and the ice maker should not be wiped, otherwise the ice will stick on the ice maker, so it will be difficult to remove.

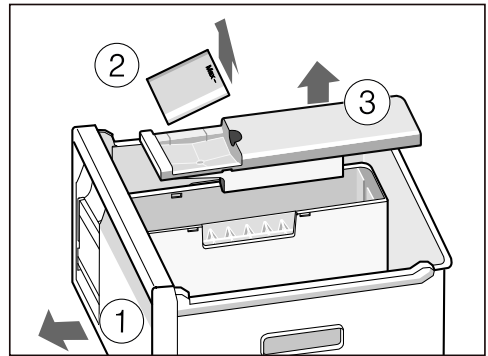

Usage

Storage period of frozen food

Symbols of different kinds of food are printed on the front of the freezer compartment drawers indicate the permitted storage period of the produce (the unit being "month").

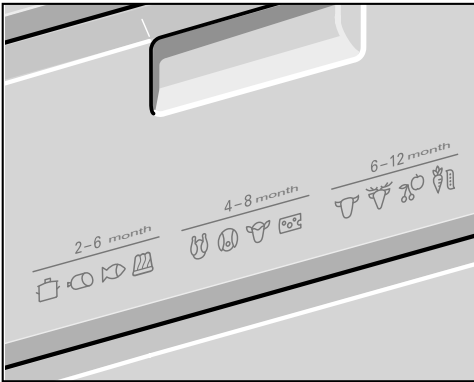

When you want to freeze food, you must take these storage time limits into account. The storing period of the food bought from the shop should be reduced correspondingly according to the production date and shelf life.

Not all the models are printed with such patterns.

Packaging frozen food

The food better be packed before freezing in order to keep the food from losing water, taste and smell bad.

Place the food in a wrapping bag and squeeze it lightly to remove the air from inside the bag as much as possible to ensure that it is sealed tight.

Each package should be labeled the date of manufacture or use by date.

Thawing frozen food

Food can be thawed at room temperature or in the refrigerator. It can also be thawed in an electric oven or in the microwave.

If you want to refreeze thawing or thawed food, you must observe the followings:

- The interval time should not be too long.
- The food is cooked, fired, boiled and roasted completely before refreeze.

Cleaning and maintenance

Defrosting

Defrosting is actuated automatically, the condensation runs through the drainage hole into an evaporation pan on the rear of the appliance.

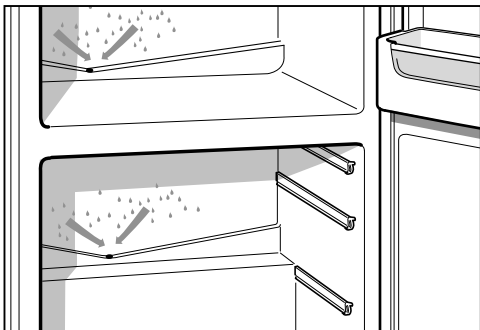

Attention

To make sure the condensation run into the evaporation pan, please do not block the drainage hole.

The drainage hole comes with a filter which can filter the dirt out. Remove the filter may result in blocking the drainage hole.

If the drainage hole is blocked, the water may accumulate at the bottom of the refrigerator compartment and the middle compartment. Remove the filter, and clean dirt inside the hole; and use soft towel to clean the collection tray at the back.

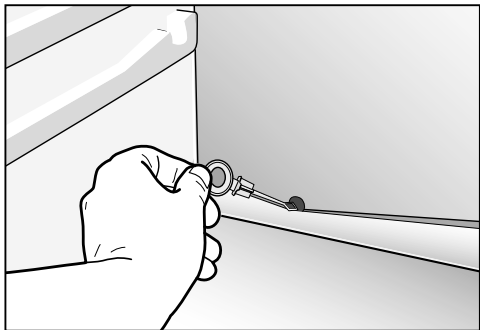

Cleaning the appliance

Precautions for internal and external cleaning of the refrigerator.

Switch off the mains plug before cleaning.

Be careful the rinsing water must not run into the light.

Clean the appliance with a soft cloth, lukewarm water and a little pH neutral washing-up liquid.

Wipe the door seal with clear water only and then wipe dry thoroughly.

Clean the collection tray and drainage hole frequently to make sure the condensation runs out smoothly.

Do not use abrasive, chloride or acidic cleaning agents or solvents.

Keep plastic parts and the door seal free of oil and grease. Otherwise, parts and door seal will become porous.

Attention

The temperature rise of the frozen food may shorten the shelf life during maintenance or cleaning.

Cleaning and maintenance

Tips for saving energy

Install the appliance in a dry, well ventilated room; The appliance should not be installed in direct sunlight or near a heat source.

Allow warm food and drinks to cool down before placing in the appliance.

Do not block the ventilation openings in the appliance.

Thaw frozen food in the refrigerator compartment.

Open the appliance as briefly as possible.

To achieve the lowest energy consumption, switch the appliance to eco mode.

Do not block the temperature sensors and avoid contact between food and sensor.

Miscellaneous

If a power failure occurs

Reduce the frequently open the door of appliance; avoid placing new fresh food inside (to prevent the temperature rising faster).

If the power suspension is noticed, select super cooling and super freezing functions to keep in a low temperatures.

Switching off the appliance

If disconnecting the appliance is necessary, switch off the appliance and pull out mains plug.

If you do not use the appliance for a prolonged period: switch off the appliance, clean the appliance and leave the appliance door open.

Do not shut down the appliance under normal conditions, this may affect the service life of the appliance.

Attention

If you decide to stop using the appliance, no food should be stored in the refrigerator.

Eliminating minor faults yourself

Symptoms which are not faults

Condensation may form on the appliance

This may occur when air humidity is high. Simply wipe dry.

Frost and ice have built up at the back of the refrigerator compartment

As the refrigerant tubes are at the back of the refrigerator, the temperature will drop below 0°C when the refrigerating unit is operating and frost may build up. When the refrigerating unit stops operating, the frost will reduce automatically.

The freezer compartment door is warm

That is normal behavior to prevent the condensation occurs on the door.

The side panels of the appliance are warm

That is normal behavior when pips run into the side panels which heat during the cooling process. When the temperature is high during summer, the temperature of the side plates may reach up to 50°C.

The compressor is hot

The compressor can reach a temperature of approx. 80°C when the refrigerator is operating.

The refrigerator makes a gurgling noise

Refrigerant is flowing through the tubing.

The refrigerator makes a clicking noise.

Refrigerating units are operating, solenoid valves are switching on and off.

The voltage is too low, the compressor cannot run

Install a power regulator of more than 500W.

The refrigerator makes a humming noise

When the refrigerator is operating, the compressor makes a slight humming sound. If the appliance is not level, it will produce vibration and noise. Place the appliance in the designated location and align.

The appliance keeps working for longer

During summer, when the ambient temperature is higher, the compressor is switching on more frequently, it is a normal behavior.

Eliminating minor faults yourself

Operating noises

Quite normal noises

Droning

Motors are running (e.g. refrigerating units, fan).

Bubbling, humming or gurgling noises

Refrigerant is flowing through the tubing.

Clicking

Motor, switches or solenoid valves are switching on/off.

Preventing noises

The appliance is not level

Please align the appliance with a spirit level. Use the height-adjustable feet or place packing underneath them.

The appliance is not free-standing

Please move the appliance away from adjacent units or appliances.

Containers or storage areas wobble or stick

Please check the removable parts and re-insert them correctly if required.

Bottles or receptacles are touching each other

Move the bottles or receptacles slightly away from each other.

Eliminating minor faults yourself

Analysis and exclusion of special conditions

Before consulting the after-sale services:

Please check whether if the failure can be solved according to the following instructions.

Fault	Possible cause	Remedial action
Displays do not illuminate.	1.The mains plug has not inserted properly, 2.The fuse has been switched off, 3.Power failure.	1.Connect mains plug, 2.Replace the fuse, 3.Check whether the power is on.
The warning signal sounds, the “alarm” is lit.	1.Appliance is powered on or restart. 2.The refrigerator door is opened for long time, 3.Too much food was placed in the freezer at once	1.To switch off the warning signal, press the button 10, 2.Close the refrigerator door completely, 3.Do not place too much food in the freezer at once.
The refrigerating system is operating properly; the lighting in the refrigerator compartment does not work.	The light is defective.	Replace the light Please contact the customer service for replacement.
Condensation occurs in the bottom of the refrigerator compartment and the middle compartment.	The drainage hole is blocked.	According to the defrosting section, clean the drainage hole.
Frostbitten vegetables	The temperature of the middle compartment is set too low.	Adjust the temperature to 0°C biological preservation.

If you cannot solve the problems described above or if other failures occur, please contact your customer service. Improper repairs may put the user at considerable risk. Repairs may be performed by the manufacturer, customer service or a similarly qualified person only. Please refer to the product warranty guide for further maintenance details.

Customer service warranty (Household use):

Within the warranty period, the whole machine warranty is free for two-year.

If you have any enquiry or maintenance service, please provide customer service with purchase receipt information.

Please provide customer service with the appliance product number (E-Nr.) and production number (FD-Nr.).

These specifications can be found on the rating plate. (on the right side of the refrigerator compartment).

目錄

產品介紹

安全與警告資訊.....	25
產品特點.....	26
處理舊電冰箱注意事項.....	27
搬運和放置.....	27
電器連接.....	28
一般規定.....	28
安裝尺寸.....	29
電冰箱詳細資料.....	30

使用

使用前準備.....	31
控制與顯示面板.....	31
開機.....	32
溫度調校.....	32
冷藏室.....	33
中間室.....	33
冷凍室.....	34

冷凍能力.....	34
製冰.....	34
冷凍食品的貯存期.....	35

清潔與維護

除霜.....	36
清潔電冰箱.....	36
節能貼士.....	36
其他事項.....	37

自行解決小故障

非故障現象.....	38
特殊現象的分析與排除.....	39

產品介紹

安全與警告資訊

使用本機器前

請仔細閱讀使用說明書！它包含有電冰箱放置、使用和保養的重要資訊。

請為日後使用保存好所有資料。

使用本機器時

- 務必使用獨立、帶可靠接地線的三芯電源插座。
- 避免擠壓、摺疊、打結或損壞電源線。如果電源線損壞，為避免危險，必須由製造廠或其維修部或符合資格的人員更換。更換電源線後電冰箱才可通電使用，否則易導致觸電甚至引發火災。
- 拔電源插頭時，不要直接拉拔電源線，以防拉斷。
- 應看管好幼兒，確保其不要玩耍和攀爬電冰箱，另外不要讓任何人爬、坐、站或倚靠在電冰箱的門上，以防造成人身傷害及電冰箱損壞。維修或清潔電冰箱時，必須拔下電源插頭。
- 僅年滿 8 歲的兒童方可使用電冰箱，讓兒童、生理、心理或感知能力受限的人士及對電冰箱的安全操作不瞭解的人士操作電冰箱可能會存在風險。必須監督或指示兒童及能力障礙人士使用電冰箱。
- 本電冰箱為家用冷藏冷凍櫃，主要用於食物的貯存和冷凍，不適用於對溫度有嚴格要求的物品（如疫苗、菌種及化學試劑等）。

- **危險**—電冰箱附近切勿存放或使用易燃物品，如煤氣，塗料，汽油等，並且禁止將易燃、易爆物品如酒精、汽油等放在電冰箱中，以防發生爆炸及火災。
- **危險**—盛載液體的玻璃瓶罐不可放在冷凍室，因為瓶罐冷凍後有爆裂危險。
- **危險**—不要將電冰箱擺放在潮濕和容易濺到水的地方。
- **危險**—勿用濕手觸摸冷凍室的食物或金屬容器，否則，易因低溫而凍傷。
- ⚠ **警告**—本產品為家用電冰箱，只適用於貯藏食品，不能用於其它用途，如貯藏血液及製品、藥物、生物製品、化學品和技術資料等。
- ⚠ **警告**—禁止損壞製冷管路。管路中的製冷劑若濺入眼睛，會造成嚴重傷害。萬一發生此類事件，應立即清洗眼睛並到醫院就診。
- ⚠ **警告**—除了本公司建議的方式外，不得使用機械設備或其他方式加速除霜過程。同時除了本公司建議使用的類型外，不得在櫃內使用電器。
- ⚠ **警告**—電冰箱頂部不宜放置和使用微波爐、電鍋、穩壓器等電器裝置，也不能在電冰箱頂部放置重物及盛有液體的容器，以防跌落傷人或液體溢出導致漏電而引起觸電和火災。
- ⚠ **警告**—易燃氣體洩漏時，應先關閉洩漏源的閥門，並設法排出室內空氣。切勿拔下電冰箱電源插座及操作電冰箱，以免發生火災。
- ⚠ **警告**—在電冰箱的外殼或嵌入式結構中，必須保持通風順暢並不得有阻礙物。

產品介紹

產品特點

多循環無霜製冷系統

冷藏室、中間室採用強制對流製冷，冷凍室採用風冷技術製冷。冷藏室、中間室和冷凍室均為自動除霜。另配有動態製冷風扇，強制冷風循環，使食物迅速冷卻並保持溫度均勻。

LCD溫度顯示

LCD液晶顯示屏分別顯示各貯藏室的設定溫度及功能狀態。外觀鮮明，一目了然，操作方便。

高效節能

採用高效節能壓縮機及加厚隔熱層，製冷效率更高、更加節能。

三獨立溫度三獨立控制

冷藏室、中間室和冷凍室均由電腦系統控制和顯示，溫度控制更精確，保鮮更長久。

智能速冷，快速方便

智能速冷功能，令冷藏室溫度迅速降至2°C，保鮮效果更好，冰鎮飲品更輕鬆。

智能速凍，強力保鮮

智能速凍功能，使食品在最短時間內凍至-18°C以下，保鮮更科學。

hyperFresh premium 0°C保鮮(中間室)

獨立製冷系統、冷風循環系統及保濕裝置，可使室內溫度控制在接近0°C。在此環境下，微生物（細菌、酵母、霉菌）的生長繁殖得到了更有效抑制，食品的保鮮時間是正常保鮮的二至三倍。

靜音技術

採用一系列降噪音技術，大大降低噪音。

闊氣候帶設計

適應的氣候類型跨越亞溫帶至亞熱帶，部分產品還能適應熱帶氣候，具體的氣候類型另見技術參數及裝箱單單頁。

R600a環保雪種，環保先鋒

環保雪種R600a和發泡劑均為碳氫化合物，不會破壞臭氧層，也不會產生溫室效應。

強化玻璃，安全可靠

強化玻璃層架安全美觀，承重能力強，優質耐用。

可拆卸門封條，清洗方便

特製可拆卸門封條，壽命長，吸附力強，清洗方便。

門警報

當使用者開門時間過長，電腦系統會自動發出警報提醒使用者關門。

溫度警報

當櫃內溫度超過警報溫度時，電腦系統會自動發出警報提醒使用者。

產品介紹

處理舊電冰箱注意事項

處理包裝材料

電冰箱包裝是為了在運輸過程中防止電冰箱損壞，所有包裝材料都利用環保可再生材料，請從環保角度將這些包裝物透過環保方式處理。請諮詢您的經銷商或當地機構瞭解處理方法。

⚠ 警告

讓兒童遠離包裝，摺疊紙箱或塑料薄膜存有窒息的危險。

舊機的廢棄

舊機並非毫無價值的垃圾!經由合乎環保標準的處理可以回收有價值的原材料。

⚠ 警告

廢棄電冰箱應按下列步驟處理：

1. 拔下電源插頭，
2. 切斷電源並且與電源插頭一同棄置，
3. 將櫃門卸下，並拆下門封條，以防止孩童被關入電器內！
4. 切勿取出層架和容器，以免孩童爬入電器內！
5. 請勿讓孩童亂玩電冰箱，有窒息危險！

⚠ 警告

電冰箱含有可燃的製冷劑和發泡層材料，製冷劑和發泡層材料應交由合資格的回收公司處理，並確保在處理前製冷管路和發泡箱體不被破壞。

搬運和放置

搬運

- ⚠ 切勿握著門或門把手來搬運電冰箱，應從底部抬起電冰箱。
- ⚠ 不宜將電冰箱橫抬或倒置。

放置

- ⚠ 電冰箱應放置在乾燥、通風的房間，且電冰箱的兩側和背面保留10cm以上空間，頂部要保留30cm以上空間。
- ⚠ 不要覆蓋或阻塞電冰箱背部的壓縮機擋板上的通風格。避免靠近熱源或陽光直接照射。

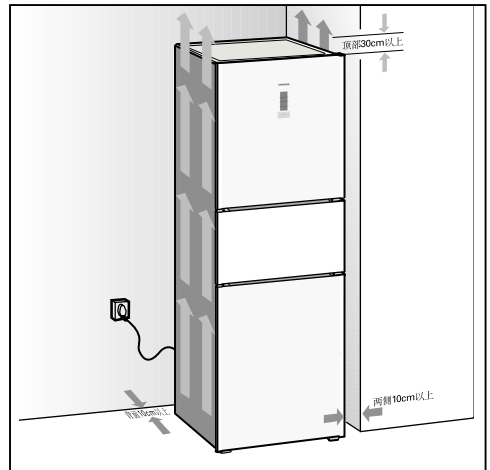

產品介紹

調整底腳

放置電冰箱時，請務必調整前面兩個塑膠底腳螺釘至適當高度。

將電冰箱放置在堅固的水平面。用扳手調整前面兩個塑膠底腳，使電冰箱保持垂直、平穩狀態。

務必使塑膠底腳螺釘與地面接觸牢靠（減小振動和噪音）。

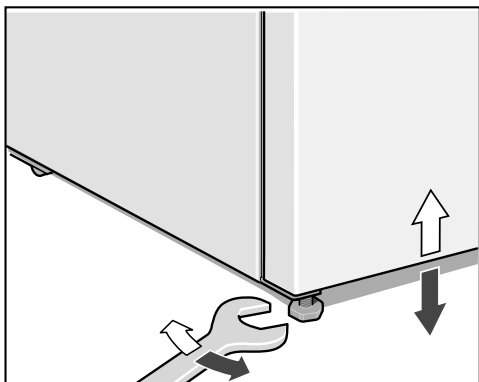

一般規定

電冰箱適用於：

- 冷藏和冷凍食品；
- 製冰。

本機器適合在家用或在家庭環境中使用。

本機器根據了歐盟指令2004/108/EC。

製冷迴圈已進行了洩漏檢測。

本產品符合有關電器產品之安全規定（IEC60335-2-24）

本產品預期最高可於海拔2000米使用。

電器連接

電冰箱的額定電壓為交流220V，額定頻率為50Hz，允許電壓波動範圍為187V~242V。

註：參照 GB/T 15945-2008《電能質量 電力系統頻率偏差》

為確保使用安全，插座及其連接電線必須能承受10A或以上的電流。

務必使用獨立、帶可靠接地線的三芯電源插座。

產品介紹

安裝尺寸

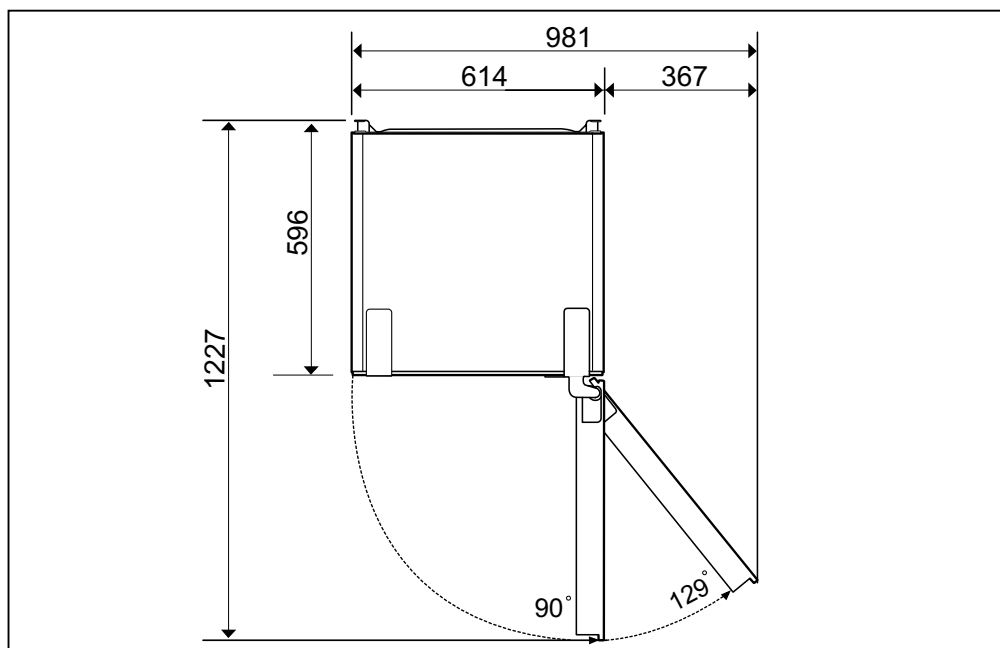
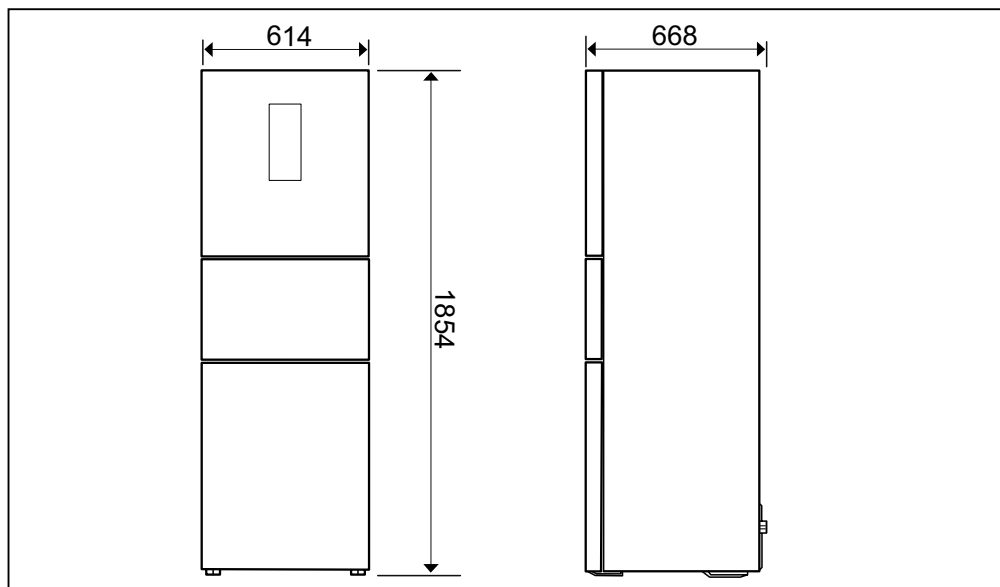

產品介紹

電冰箱詳細資料

本使用說明書適用於多種型號。

不同型號的功能可能會有不同。本手冊所有圖解均為示意圖，

因此某些特徵和裝置可能與圖示有所差異，具體結構及配置請以產品為準。

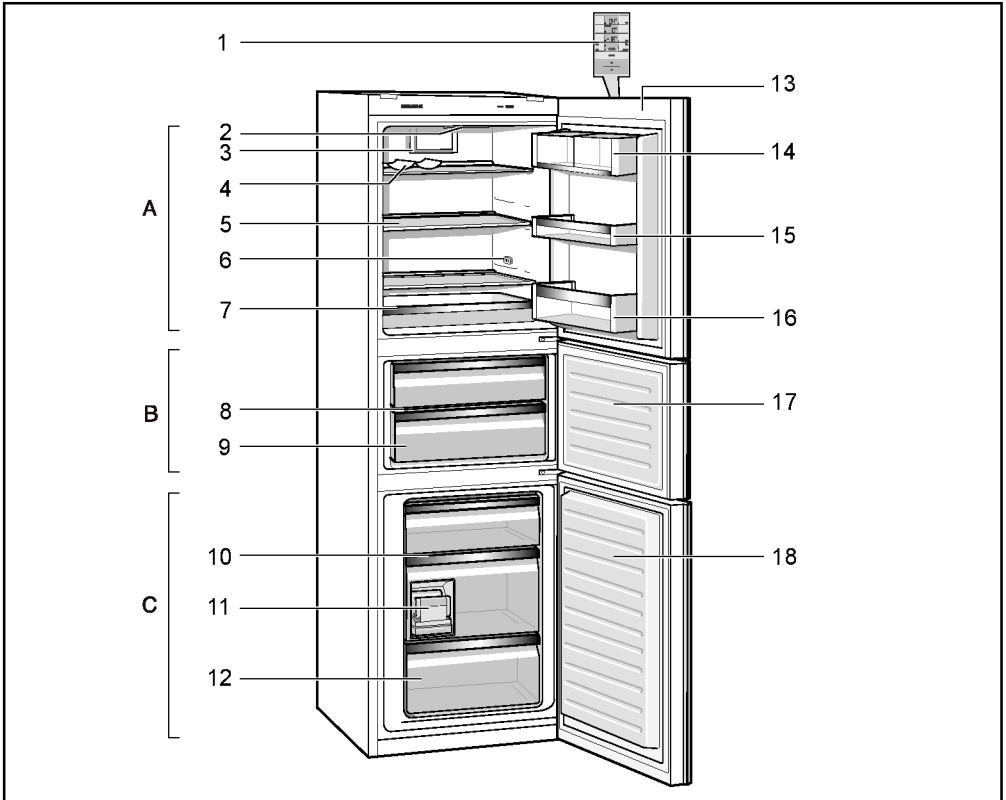

- | | | |
|------------|------------|-----------|
| 1 控制與顯示面板 | 7 冷藏室抽屜 | 13 冷藏室門 |
| 2 照明燈(LED) | 8 鎖濕過濾網 | 14 乳製品貯存格 |
| 3 風扇 | 9 中間室抽屜 | 15 小瓶架 |
| 4 瓶架 | 10 冷凍室玻璃層架 | 16 大瓶架 |
| 5 冷藏室玻璃層架 | 11 旋轉製冰格* | 17 中間室門 |
| 6 感應器 | 12 冷凍室抽屜 | 18 冷凍室門 |

- A 冷藏室
B 中間室
C 冷凍室

* 並非所有型號

使用

使用前準備

拆除所有包裝元件，包括電冰箱底部的泡沫墊及櫃內固定附件用的泡沫墊和膠帶。

按照裝箱單點算隨機附件和資料。

參照「搬運和放置」中的相關內容將電冰箱擺放到合適的位置。

參照「清潔電冰箱」中相關的內容清洗電冰箱的外部 and 內部。

在接通電源之後，應讓電冰箱靜置30分鐘以上。

控制與顯示面板

控制與顯示面板配置溫度顯示屏，所有功能和溫度調校都透過觸摸按鈕以選擇和調校。以下分別說明各按鈕的名稱及功能。

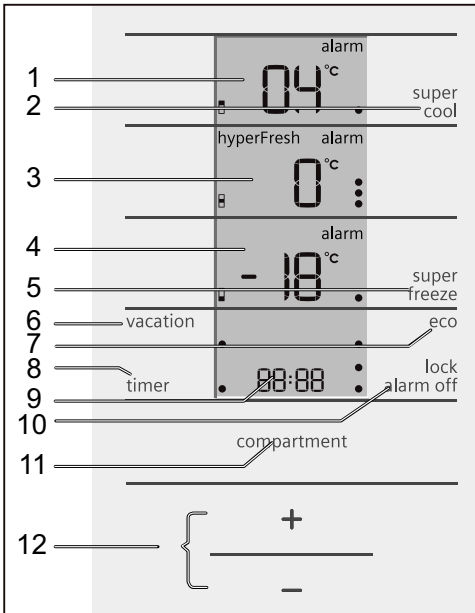

- 1 冷藏室顯示區**
顯示冷藏室目前的溫度設定及相關狀態。
- 2 Super極速冷藏按鈕**
觸摸按鈕2可打開或關閉 Super 極速冷藏功能。
在Super極速冷藏狀態下,冷藏室溫度設定為2°C並持續運行6小時。
- 3 中間室顯示區**
顯示中間室的設定溫度及相關狀態。
- 4 冷凍室顯示區**
顯示冷凍室目前的溫度設定及相關狀態。
- 5 Super極速冷凍按鈕**
觸摸按鈕5可打開或關閉 Super極速冷凍功能。
在Super極速冷凍狀態下,冷凍室溫度設定為-30°C並持續運行54小時。
- 6 vacation假日模式按鈕**
觸摸該按鈕,進入假日模式,冷藏室顯示14°C,中間室和冷凍室仍然保持原本的溫度設定。
- 7 eco節能模式按鈕**
觸摸該按鈕,冰箱將在節能模式狀態下運行。
- 8 timer定時器按鈕**
- 9 定時器顯示區**
- 10 lock/alarm off**
開啟或關閉面板安全鎖功能;持續按住該按鈕3秒;該按鈕同時也可用於解除警報訊號。
- 11 各區溫度設定按鈕**
- 12 溫度調校按鈕**

使用

開機

初次通電時

插好電源線，接通電源。

如果控制顯示面板無任何顯示，請檢查電源插頭是否插好。

首次開機時，冷藏室和冷凍室均顯示各自的溫度設定值（電冰箱出廠時冷藏室設定為4°C，中間室為0°C，冷凍室為-18°C）。

如果櫃內溫度高於電冰箱的警報溫度，警報字樣和冷凍室的溫度將閃爍顯示，且警告訊號響起。觸摸按鈕10，關閉警告訊號聲，警報字樣停止閃爍，冷凍室顯示區顯示曾達到的最高溫度5秒，然後顯示設定溫度。當櫃內溫度低於警報溫度時，警報字樣將停止顯示。

當開機數分鐘後，電冰箱兩側會有溫熱感，表示製冷系統現正工作。

溫度調校

冷藏室溫度調校

通過觸摸按鈕11來啟動冷藏室溫度顯示區1，接著用觸摸按鈕12中的 + 或 - 來調校所需的冷藏室溫度(可在2°C~8°C之間進行調校)。

當貯存容易腐爛的食物時，建議把冷藏室的溫度設定在4°C以下。

中間室溫度調校

通過觸摸按鈕11來啟動中間室溫度顯示區3，接著用觸摸按鈕12中的 + 或 - 來調校所需的中間室溫度(可在-3°C~6°C之間進行調校)。

當貯存新鮮蔬果時，建議將中間室的溫度設定為0°C。

冷凍室溫度調校

通過觸摸按鈕11來啟動冷凍室溫度顯示區4，然後透過觸摸按鈕12中的 + 或 - 來調校所需的冷凍室溫度(可在-16°C~-24°C之間進行調校)。

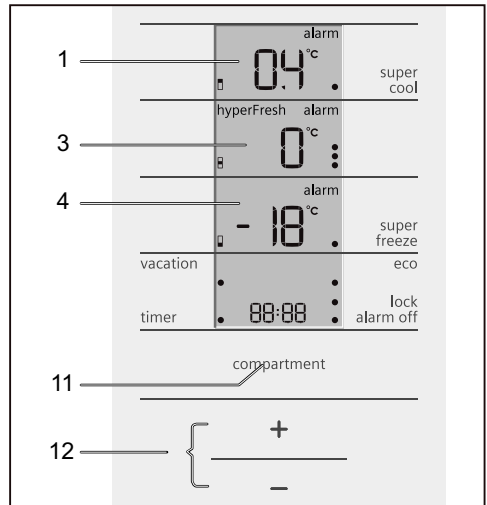

溫度設定值即使在斷電之後，也無需重新設定。

使用

冷藏室

冷藏室主要用於短期貯存的食物。

玻璃層架

冷藏室玻璃層架的位置可以調整，方便貯存各種食物。

將玻璃層架向外拉出一半，再抬高層架的前部便可取出層架。

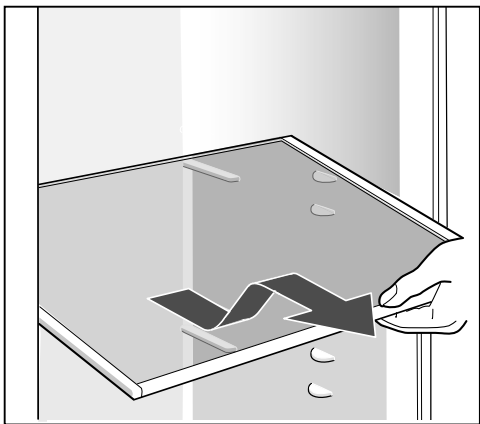

乳製品貯存格可放置芝士等需要隔開氣味的食物，可以按需要重新佈置，將貯存格向上輕輕抬起便可取出。

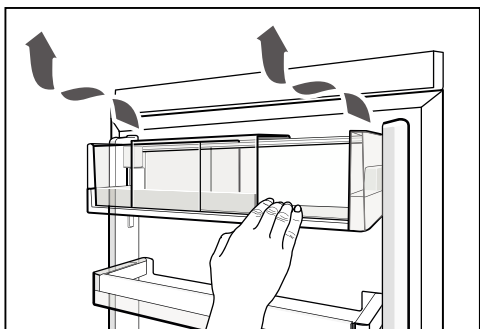

門上瓶架用於貯存雞蛋、瓶裝飲品以及各類食物。

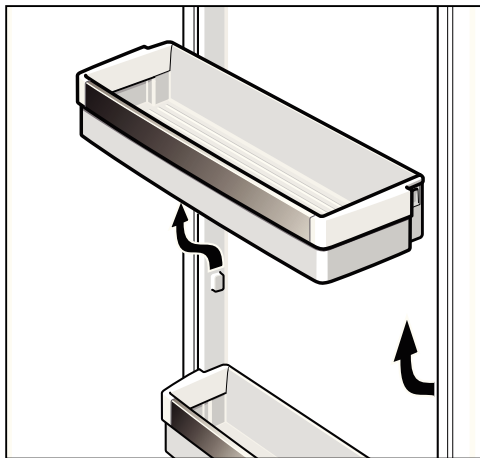

中間室

中間室的溫度範圍是 -3°C ~ 6°C 之間，有兩種溫度顯示狀態：當溫度顯示 0°C 時，只出現「hyperFresh」字樣；當溫度顯示為其它溫度時，就無其字樣顯示。

中間室在通常情況下預設為hyperFresh premium 0°C 保鮮室設置，此時，可最大限度保持濕度，食物的保鮮時間是正常保鮮的二至三倍。適合貯存鮮魚、鮮肉、鮮蛋、牛奶、蔬菜及水果等。

抽屜

中間室內有兩個帶導軌的抽屜，方便放入或取出食物。

將抽屜導軌和抽屜一併拉出，握住把手並抬起抽屜的後端，使抽屜導軌和抽屜分離，便可拿開抽屜。

安裝抽屜時，首先拉出導軌，把抽屜放在導軌上，用手指固定導軌同時將抽屜推入，直至導軌和抽屜完全接上。

使用

冷凍室

冷凍室主要用於冷凍食品，貯存已冷凍的食品及製冰。可較長時間地貯存食品。

冷凍室配有抽屜，將抽屜向外拉出後輕輕抬高便可取出。

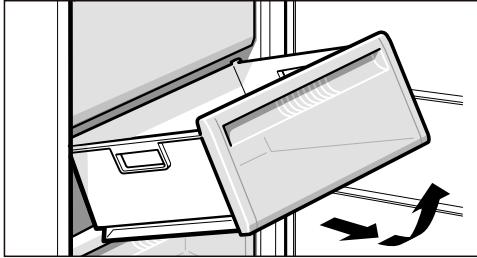

上層抽屜和中間抽屜可大量地冷凍和貯存食品。

下層抽屜主要用於貯存已冷凍的食品。

冷凍室抽屜屬於配件，是為了方便使用者而配置，使用者也可以將抽屜取出，將食品直接放在冷凍室玻璃層架上。

注意：玻璃層架遇熱有機會爆裂，請勿存放熱的食物在玻璃層架上。

中抽屜用於冷凍和貯存體積較大的食品，例如火雞、鴨和鵝。如果需要更大空間，可取下旋轉製冰格。（僅針對部份型號）

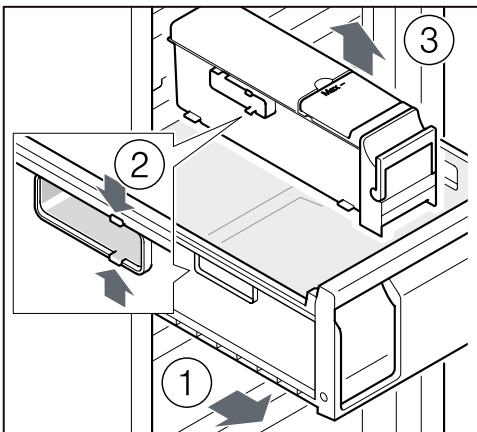

冷凍能力

銘牌上標示的冷凍能力，根據IEC 62552，在標準情況下測試並計算所得的冷凍食品量。

製冰

為便於快速製冰，在開始製冰前，應將冷凍室的溫度調校至最低設定值或開啟 Super 極速冷凍功能。

僅可使用飲用水來製冰。

在製冰格內倒入飲用水，以注滿每個製冰格為準，然後水平放置在冷凍室的第二層抽屜內。

在製冰盒內注入飲用水時，應只需注滿每個製冰格即可，否則過多的飲用水會使冰面連成一體而不方便拿取冰塊，還會延長製冰時間。

24小時製冰量最多為1500克。通常每次製冰時間約為3小時。

提取冰塊時，稍微扭動製冰格兩端，冰塊就會脫落。

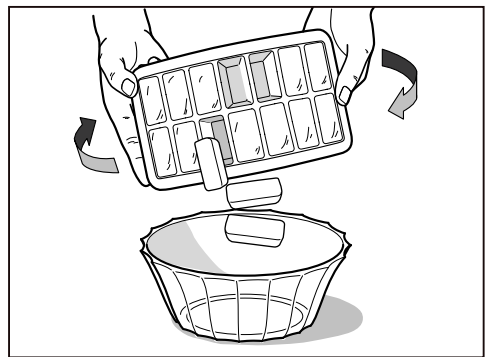

使用

對於部份型號配置有旋轉製冰格，請按照下列方法製冰。

為方便快速製冰，在開始製冰前，應將冷凍室的溫度調校至最低設定值或開啟**Super** 極速冷凍功能。

僅可使用飲用水製冰。

24小時製冰量最多為**1000**克。通常每次製冰時間約為**3**小時。

1. 取出儲水盒，並注滿飲用水至標記線。
2. 把飲用水倒入製冰格填充口。
3. 重新插入儲水盒。
4. 製冰完成後，向下按製冰盒把手，冰塊會落入儲冰盒中。
5. 拉出儲冰盒取出冰塊。

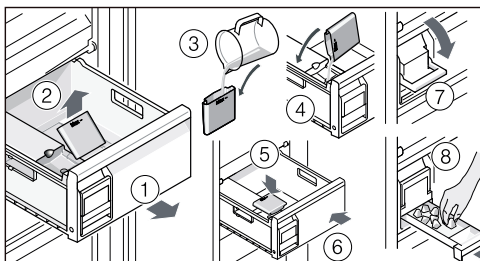

清潔儲冰盒

初次製冰或長期沒有製冰的情況下，需要清潔儲冰盒。

1. 拉出抽屜，取出儲水盒及製冰盒上的蓋子。
2. 用清水輕輕清洗，不得擦拭儲冰盒，否則會造成冰塊粘在儲冰盒上，不易取下。

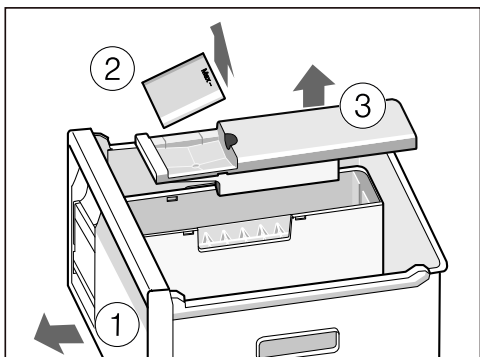

冷凍食品的貯存期

冷凍室抽屜前方印有各類食品圖案以及各類食品貯存的參考期限（以「month」為單位）。

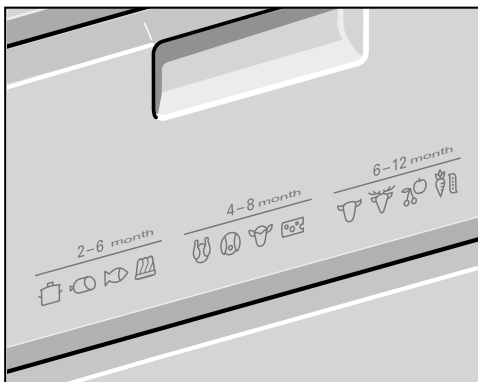

冷凍食品時，須考慮其貯存期限。從商店購買的食品，要根據生產日期和保質期，相應縮短其貯存時間。

並非所有型號都印有此類圖案。

冷凍食品的包裝

食品在冷凍之前最好要包裝好，這樣能防止食品水分流失以及變質、變味和氣味轉移。

把食品放入包裝袋內，並輕輕擠壓，以儘量排出包裝袋內的空氣，將包裝密封。

每個包裝在冷凍前貼上標籤，並標明冷凍日期。

冷凍食品的解凍方法

在室溫下或冷藏室內，也可在電爐上或微波爐內。

如果您需要再次冷凍已解凍的或剛解凍的食品，須注意以下事項。

- 間隔時間不宜過長。
- 最好在冷凍之前進行煮、煎、烤或徹底烹煮透。

清潔與維護

除霜

電冰箱自動除霜，冷凝水透過水管流出電冰箱後部的接水盤，並利用壓縮機熱力自行蒸發。

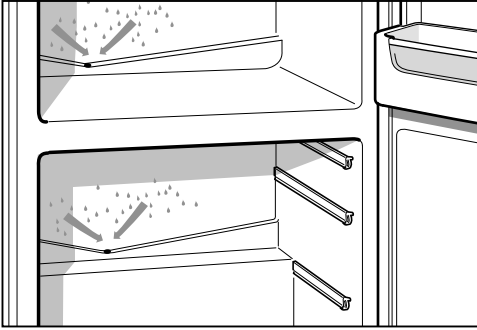

注意

為使冷凝水順暢流出，請保持出水孔不被其它物體遮擋。

本產品出水孔處自帶濾潔器，可過濾污物，建議不要取出，否則易造成出水孔阻塞。

若出水孔阻塞，容易造成冷藏室和中間室底部積水。請取出濾潔器，用濾潔器的末端清潔孔內污物，用軟毛巾清潔孔外及接水槽處污物，最後清洗濾潔器並將其重新置於孔內。

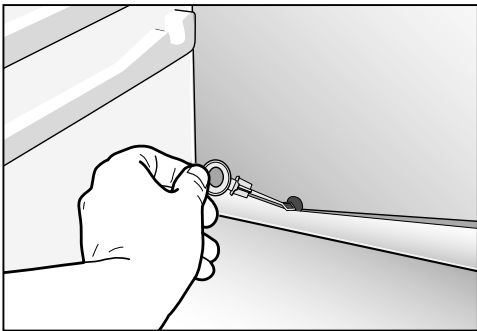

清潔電冰箱

電冰箱內部及外部清潔應注意事項。

清潔前，必須拔下電源插頭。

清潔時，確保水不能進入照明燈裝置內。

除門封條外，用軟毛巾沾溫水或中性清潔劑擦洗箱體。

清潔門封條時，必須用清水，並且用乾布抹乾淨。

經常清潔接水槽和出水孔，以保持冷凝水能順利流出。

不要用含有研磨劑（例如牙膏）、酸性物質、化學溶劑（例如酒精）或含有擦光劑的清潔劑擦洗。

應及時清理接觸到電冰箱塑膠部件及門封條的油或油脂，否則油污可能引起部件損壞。

注意

維護或清潔時，冷凍食品溫度回升可能會縮短貯存期。

節能貼士

將電冰箱放置在乾燥及良好通風處，確保電冰箱不靠近熱源及不暴露在陽光直接照射下。

高溫食品應冷卻至室溫，再放入電冰箱。

不要遮擋冷凍室內風道上的出口，以便冷風可以循環暢通。

冷凍食品放在冷藏室解凍，可輔助冷藏室製冷。

儘量縮短電冰箱的開門時間。

從保鮮和節能的角度考慮，推薦用戶在一般環境溫度下使用節能模式。

確保電冰箱的溫度感應器不要被覆蓋或與物品接觸。

清潔與維護

其他事項

停電時

要減少電冰箱的開門次數，避免再放入新食品（防止櫃內溫度回升加快）。

如果事先知悉停電，可提前開啟Super極速冷藏和冷凍功能，使櫃內溫度冷卻至更低值。

停止使用電冰箱

如果需要關機可拔下電源插頭。

如果您決定將電冰箱停用一段時間，按下列步驟進行：首先關機，然後清潔，最後應稍微打開櫃門，可減少不良氣味產生。

一般情況下不要停用電冰箱，否則會影響電冰箱的壽命。

注意

如果您決定停用電冰箱，櫃內不能存放任何食品。

自行解決小故障

非故障現象

電冰箱外表面出現霧狀凝露

當空氣濕度較大時，會出現這種現象，抹乾即可。

冷藏室內背部結霜

因冷藏室製冷管路位於冷藏室的背部，在冷藏室工作時，此處溫度低於0°C而發生結霜現象，當製冷系統停止工作後便會自動除霜。

冷凍室門框四周發熱

這是防止冷凍室門結冰或產生凝露所採取的一種特殊措施。

左右側板發熱

冷凝器緊貼左右側板內側，電冰箱工作時，透過冷凝器向外散熱。夏季環境溫度較高，側板溫度可達50°C左右。

壓縮機發燙

在電冰箱工作時，壓縮機外殼溫度可達80°C左右。

電冰箱有「噝噝」流水聲

這是製冷系統工作時製冷劑在製冷管路內流動的聲音。

電冰箱有輕微的「啪啪」聲響

電冰箱工作時，由於內膽和製冷管路熱脹冷縮而引起。

電壓過低，壓縮機未能啟動

配備500W以上的電源穩壓器。

電冰箱有「嗡嗡」的振動聲

電冰箱工作時，壓縮機會發出輕微的「嗡嗡」聲。如果電冰箱沒有放置平穩，會產生振動和噪音，請參照「搬運和放置」的相關內容把電冰箱調整至平穩以減小振動。

開機時間較長

夏季，由於環境溫度較高，壓縮機啟動次數較多，開機時間較長為正常現象。

運轉噪音

完全正常的噪音

嗡嗡聲

壓縮機運轉（比如冷凍機組、風扇）。

氣泡、沙沙聲或咯咯聲

冷媒流過冷媒配管。

微弱喀嚓聲：

開啟或關閉壓縮機、開關或電磁閥。

避免噪音

機器擺放不平

請使用水平儀校準機器的水平。對此，請您使用螺絲支腳或 在底部墊些物品。

機器“靠在一起”

請將與機器靠在一起的家具 或家電移開。

貯藏盒或瓶架搖晃或夾住

請檢查所有可取出的零件，必要時請重新插入。

瓶子或容器互相碰撞

請將瓶罐稍微地移動隔開。

自行解決小故障

特殊現象的分析與排除

在向售後服務諮詢之前：

請您檢查是否能夠按照下列說明自行解決故障。

故障現象	可能原因	解決辦法
控制面板無任何顯示。	1. 電源插頭未插好， 2. 電源保險絲被切斷， 3. 停電。	1. 插好電源插座， 2. 更換保險絲， 3. 檢查是否停電。
警報器發出警報及同時閃爍顯示「alarm」字樣。	1. 首次開機或長時間斷電後再開機， 2. 長時間打開電冰箱門， 3. 一次性放入冷凍室過多的食品。	1. 觸摸按鈕10取消警報聲， 2. 關好電冰箱門， 3. 一次性放入冷凍室的食品不宜過多。
製冷系統工作正常，冷藏室照明燈不亮。	照明燈裝置已損壞。	更換照明燈裝置 請聯絡客戶服務更換。
冷藏室及中間室底部潮濕或有積水。	接水槽上的出水孔阻塞。	按照「除霜」中的相關內容，清理接水槽上的出水孔。
蔬菜凍傷	中間室設置溫度過低。	調校設置溫度至0°C生物保鮮。

如果上述故障現象仍不能排除或出現了上述現象以外的故障，請務必與客戶服務部門聯絡。不得自行拆修或委託非本公司指定的專業人員維修，否則由此造成的電冰箱損壞或人身傷害，本公司概不負責。具體維修細則另見產品保修指南。

客戶服務保證（家庭使用）：

保修期內，全機免費保修兩年。

當您需要正常諮詢或維修時，請持有發票與本公司客戶服務部門聯絡。

在您諮詢或報修時，請向服務人員告知產品代碼（E-Nr.）、生產日期（FD）。

在產品銘牌標籤上可以獲得這些資訊（於電冰箱冷藏室右側）。

BSH Hausgeräte GmbH
Carl-Wery-Str. 34,
81739 Munich, Germany

siemens-home.bsh-group.com

Manufactured by BSH Home Appliances CO.,LTD. under Trademark License of Siemens AG

8001045123(PD9705)